

OLYMPUS[®]

Your Vision, Our Future

Innovation in **NDT**[™]



Product Catalog



920-087

- Eddy Current Probes
- Ultrasonic Transducers
- Engine Probes
- EC and UT Reference Standards

NDT *engineering*
corporation

Olympus NDT

Olympus NDT is a leading global manufacturer of innovative nondestructive testing instruments that are used in industrial and research applications ranging from aerospace, energy, automotive, and electronics to manufacturing. Olympus NDT instruments contribute to the quality of products and add to the safety of infrastructure and facilities. They include flaw detectors, thickness gages, bond testers, pulser-receivers, transducers, and advanced systems for inline applications. Our leading edge technologies include ultrasound, ultrasound phased array, eddy current, and eddy current array.

Olympus NDT offers products and services from several high quality brands: R/D Tech®, Panametrics-NDT™, NDT Engineering, Sonic®, and Nortec®. For many decades these brands have earned excellent reputations for providing cost-effective solutions and excellent support and customer service.

Based in Waltham, Massachusetts, USA, the company has sales and service centers in all principal industrial locations worldwide. Visit www.olympusNDT.com for applications and sales assistance near you.

NDT Engineering Corporation

NDT Engineering Corporation, a subsidiary of Olympus NDT inc., is one of the world's largest designer, manufacturer, and marketer of probes and transducers for EC and UT inspection. Our products include eddy current probes, ultrasonic transducers, engine probes, and reference standards in addition to the full service capabilities of EDM and repair services. Our products can be found in commercial, commuter, and military aircraft NDT documents.

NDT Engineering offers over 10,000 standard and custom-designed EC probes, UT transducers, reference standards, and accessory items for virtually every application. This catalog is a representative sample of our total product line. For applications that require a nonstandard product, we proudly offer the most comprehensive custom probe and application services available anywhere.



- **Eddy current probes**
- **Ultrasonic transducers**
- **Engine probes**
- **EC and UT reference standards**
- **Probe kits**
- **TTU equipment for graphite and bonded structures**
- **Connecting cables and adapters**
- **Probes and tooling for restricted access and precise positioning**
- **Repair services**
- **Full service EDM notching for reference standards**

NDT Engineering Corporation

**19620 Russell Rd.
Kent, WA 98032
USA**

**Telephone: (1) (253) 872-3565
Fax: (1) (253) 872-0857**

**www.ndteng.com
ndteng@olympusNDT.com**

Table of Contents

Introduction.....	ii	Probe Kits	35
Olympus NDT	ii	Hole Probes.....	35
NDT Engineering Corporation	ii	Surface Probes.....	35
General Information.....	2	Low-Frequency Probes	35
Eddy Current Products	3	Ultrasound Products	36
Ordering Information	3	Ordering Information	36
Bolt Hole Probe Sizing Chart	4	Contact Transducers	37
Bolt Hole Probes	5	Standard.....	37
Universal Rotor.....	5	Delay Line.....	38
Foerster Rotor	5	Dual Element - Cylindrical.....	39
Nortec Rechii Rotor.....	6	Shear Wave Transducers	40
Nortec PS5 Rotor.....	6	Micro Miniature.....	40
Zetec® Rotor.....	7	Subminiature	41
Elotest Standard Rotor.....	8	Miniature.....	42
Elotest Mini Rotor.....	8	0.375 in. Element.....	43
Rotary Countersink	9	0.500 in. Element.....	43
Manual Standard	10	SwiftChange™ Transducers and Wedges	44
Manual Countersink	11	Immersion Transducers.....	45
Manual for Locator UHB	11	Standard and Slim-Line.....	45
Adjustable Diameter	12	Cables, Kits, and Miscellaneous	
Adjustable Diameter	13	UT Accessories.....	46
Adjustable Diameter	14	Cables and Extensions.....	46
Adjustable Diameter	15	Custom Kits and Guides	46
Surface Probes.....	16	Transducer Certification	47
Straight - Microdot	16	Roller Probes, Yokes, and Gimbals.....	48
Straight - Fischer® Triax.....	16	Waterjet Yokes, Nozzles, and	
Straight - Microtip	17	Nozzle Transducers	49
Straight - Plastic Tip.....	17	Reference Standards.....	50
Right Angle Tip 0.5 in. Drop	18	Aircraft Standards	50
Right Angle Tip 0.2 in. Drop	19	Hole Standards.....	51
Right Angle Tip 0.03 in. Drop	19	Surface Standards.....	51
45° Tip (0.5 in. Drop).....	20	Ultrasonic Standards.....	52
45° Tip (0.3 in. Drop).....	20	Composite Standards	53
30° Tip (0.5 in. Drop).....	21	Technical Notes	54
Defectometer Probes	22	Eddy Current Tutorial and	
Hole Probes	22	Probe Selection Information	54
Surface Probes.....	23	Probe Types and Their Usage.....	56
Low-Frequency Probes.....	24	Troubleshooting.....	57
Spot Bridge	24	Legal Notices.....	58
Ring Bridge.....	25	Disclaimer	58
Spot Reflection.....	26	Legal Notices.....	59
Ring Reflection	27		
Miscellaneous Probes	28		
Sliding Probes	28		
Wheel Probes	29		
Wheel Standards.....	29		
Blade	30		
Finger	30		
Spring Loaded.....	31		
Flexshaft.....	31		
Cables and Adapters.....	32		
Reference Coil Adapters and Cables	32		
Rotary Adaptors	32		
Bridge Cables and Adapters	33		
Reflection Cables and Adapters	34		

NDT Engineering

We Would Like to Help You!

- By continuing to develop solutions concerning inspection requirements for commercial and military aircraft.
- By solving your eddy current and ultrasonic inspection problems.
- By meeting your aircraft on ground (AOG) or other on time delivery requirements.
- By shipping you quality products that are backed by a lifetime guarantee against manufacturing defects.
- By providing no-cost, quality, technical support by phone, fax, or e-mail.

General Information

Fast Delivery

Because we know that fast delivery is important for most of our customers, we work very hard to meet or exceed all delivery requirements. Whether it is an AOG or some other urgent requirement and that our customer must have it by a specific date, that delivery will become our very highest priority.

The Best Quality and Service

As with any company, the day-to-day capability lays with its employees, and we are fortunate to have outstanding talents with experience dating back to the early days of EC and UT implementation in the 1950s. We also boast major upgrades and improvements in both equipment and personnel to our EDM shop and our quality control. We are now able to facilitate all of our customer needs while maintaining the strictest of controls on the quality of our products. This enables us to quickly serve the marketplace with products of exceptional quality and value. NDT Engineering's commitment to providing the very best customer service is evidenced by ongoing investments in manufacturing technology and productivity-enhancing equipment.

New Products

Numerous products are not included in this catalog as we are constantly developing new probes and transducers to solve problems for an ever-changing industry. To that end, we have developed a team of highly qualified individuals who are at your disposal, ready to design and manufacture a solution for your next problem. So, if what you are looking for is not in this catalog, call us and we will get you what you need.

Repair Services

NDT Engineering will replace defective probes or transducer from any manufacturer at a repair cost:

Eddy current probes

Engine probes

UT transducers

Adapters

Cable assemblies

TTU equipment

We guarantee to return repaired items in like-new condition with new product warranty at a price of 15% to 40% below the cost of new. Cost depends on the extent of repair and replacement parts required. Items can be submitted for a price quote prior to repair, but if the customer decides against repair, the cost of return shipping will be the responsibility of the customer.

Warranty

All items sold by Olympus NDT under the NDT Engineering brand are warranted against manufacturing defects. Wear, damage, misuse, and corrosion are not covered by warranty. Warranty length is per the following table:

Items	Warranty Length
EC Probes	Lifetime
UT Transducers	Six (6) months
Adapters	Lifetime
Reference Standards	Lifetime

All items returned under warranty must reference an RMA number (returned material authorization), which must be requested from our office and visibly written on returned goods packaging.

If it is determined that wear, damage, or corrosion is due to faulty materials or design, the item will be replaced at no charge. Warranted items will be repaired to like new condition or replaced as determined by NDT Engineering. These items will have a full warranty starting at the date the customer receives the returned item.

The customer will pay shipping and duty costs as applicable, and then ship the item to:

NDT Engineering Corporation
19620 Russell Road, Kent, WA 98032
USA

NDT Engineering will pay return shipping costs via the most economical means that have a shipping period of less than 10 days. Shipping period is defined as the length of time in transit between the departure from our plant and the arrival at destination. This excludes delays such as customs in the destination country.

Eddy Current Products

Ordering Information

The basic part numbers found in this catalog follow a logical, easy to use, numbering format; however, when adding options, it is important to remember the three following rules:

1. Every item in this catalog begins with a **letter** or **letters** that relate to its corresponding product such as "BP" for bolt hole probe, "MP" for micro (surface) probe, etc.
2. Letters are then followed by a set of numbers that signify either a hole size, length, OD, or angle and drop length (in the case of surface probes), etc.
3. Option letters are added at the end of the basic part number to designate special inspection requirements or user requirements (see following lists).

Option list 1 – without slash (placed after basic part number on surface probes)

FX 1/8 in. diameter flexible shaft

B bent shaft convenient handle

C curved angle drop (offered on all angled surface probes 0.30 in. drop or longer)

Option list 2 – with slash (placed after basic part number or any option from list 1)

/SE spread-end tip

/SS stainless steel body

/TF Fischer® triax connector

/4F 4-pin Fischer connector

/7L Staveley PowerLink™

/200K-1M 500 kHz center frequency

/1-3M 2 MHz center frequency for MP

/1-6M 2 MHz center frequency for MTF only

/x.xWL working length in inches

/x.xMWL working length in millimeters

/x.xOAL overall length in inches

/x.xMOAL overall length in millimeters

With these options in mind, part numbers can be built as shown in the examples below.

MP905-50FX/1-3M

Basic part number:

Shielded surface probe with a right angle 1/2 in. drop and a 5 in. length.

Options:

FX: flexible copper shaft

/1-3M: center frequency 2 MHz

BPU-5.0M/SS/50MWL

Basic part number:

Universal rotary bolt hole probe with a 5 mm diameter.

Options:

/SS: stainless steel

/50MWL: 50 mm working length

LR017-1/TF

Basic part number:

Low-frequency, bridge type ring probe center frequency at 100 Hz and an OD of 0.7 in.

Options:

/TF: Fischer triax connector

Note: not all options are available for all products

Bolt Hole Probe Sizing Chart

Size	8	9	10	11	12	13	14	15	16	17
Head diameter	1/8 in.	9/64 in.	5/32 in.	11/64 in.	3/16 in.	13/64 in.	7/32 in.	15/64 in.	1/4 in.	17/64 in.
	0.125	0.140	0.156	0.171	0.187	0.203	0.218	0.234	0.250	0.265
	3.18 mm	3.57 mm	3.97 mm	4.37 mm	4.76 mm	5.16 mm	5.56 mm	5.95 mm	6.35 mm	6.75 mm
Size	18	19	20	21	22	23	24	25	26	27
Head diameter	9/32 in.	19/64 in.	5/16 in.	21/64 in.	11/32 in.	23/64 in.	3/8 in.	25/64 in.	13/32 in.	27/64 in.
	0.281	0.296	0.312	0.328	0.343	0.359	0.375	0.390	0.406	0.421
	7.14 mm	7.54 mm	7.94 mm	8.33 mm	8.73 mm	9.13 mm	9.52 mm	9.92 mm	10.32 mm	10.72 mm
Size	28	29	30	31	32	33	34	35	36	37
Head diameter	7/16 in.	29/64 in.	15/32 in.	31/64 in.	1/2 in.	33/64 in.	17/32 in.	35/64 in.	9/16 in.	37/64 in.
	0.437	0.453	0.468	0.484	0.500	0.515	0.531	0.546	0.562	0.578
	11.11 mm	11.51 mm	11.91 mm	12.30 mm	12.70 mm	13.10 mm	13.49 mm	13.89 mm	14.29 mm	14.68 mm
Size	38	39	40	41	42	43	44	45	46	47
Head diameter	19/32 in.	39/64 in.	5/8 in.	41/64 in.	21/32 in.	43/64 in.	11/16 in.	45/64 in.	23/32 in.	47/64 in.
	0.593	0.609	0.625	0.640	0.656	0.671	0.687	0.703	0.718	0.734
	15.08 mm	15.48 mm	15.88 mm	16.27 mm	16.67 mm	17.07 mm	17.46 mm	17.86 mm	18.26 mm	18.65 mm
Size	48	49	50	51	52	53	54	55	56	57
Head diameter	3/4 in.	49/64 in.	25/32 in.	51/64 in.	13/16 in.	53/64 in.	27/32 in.	55/64 in.	7/8 in.	57/64 in.
	0.750	0.765	0.781	0.793	0.812	0.828	0.843	0.859	0.875	0.890
	19.05 mm	19.45 mm	19.84 mm	20.24 mm	20.64 mm	21.03 mm	21.43 mm	21.83 mm	22.23 mm	22.62 mm
Size	58	59	60	61	62	63	64	68	72	76
Head diameter	29/32 in.	59/64 in.	15/16 in.	61/64 in.	31/32 in.	63/64 in.	1	1 1/16 in.	1 1/8 in.	1 3/16 in.
	0.906	0.921	0.937	0.953	0.968	0.984	1	1.062	1.125	1.187
	23.02 mm	23.42 mm	23.81 mm	24.21 mm	24.61 mm	25.00 mm	25.40 mm	27.0 mm	28.58 mm	30.16 mm
Size	80	84	88	92	96	104	112	120	128	136
Head diameter	1 1/4 in.	1 5/16 in.	1 3/8 in.	1 7/16 in.	1 1/2	1 5/8 in.	1 3/4 in.	1 7/8 in.	2.00	2 1/8 in.
	1.250	1.312	1.375	1.437	1.500	1.625	1.750	1.875	2.00	2.125
	31.75 mm	33.34 mm	34.93 mm	36.51 mm	38.1 mm	41.28 mm	44.45 mm	47.63 mm	50.8 mm	53.98 mm
Size	144	152	160	168	176	184	192			
Head diameter	2 1/4 in.	2 3/8 in.	2 1/2	2 5/8 in.	2 3/4 in.	2 7/8 in.	3.0			
	2.250	2.375	2.500	2.625	2.750	2.875	3.00			
	57.15 mm	60.33 mm	63.5 mm	66.68 mm	69.85 mm	73.03 mm	76.2 mm			

Bolt Hole Probes



Universal Rotor

Foerster Rotor

Standard Configuration

Universal Rotor

- 100 kHz–2 MHz
- Black plastic body

Foerster Rotor

- 100 kHz–2 MHz
- Black plastic body

Next Page

Rechii Rotor

- 100 kHz–2 MHz
- Black plastic body

Working length for Rechii rotor is per the following table:

Size range	WL
Less than -18	1.1 in.
-18 or greater	1.5 in.
-18/SE or greater	2.0 in.

Universal, Foerster and PS5 Rotor

- 100 kHz–2 MHz
- Black plastic body

Working length is per the following table:

Size range	WL
8–15	1.1 in.
16–64	2.0 in.

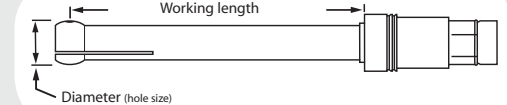
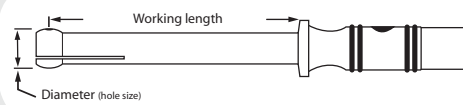

Options

Add to end of part number if other than standard	/SE: spread end
	/SS: stainless steel
	/x.xWL: working length
	/x.xOAL: overall length

Hole size			Universal Rotor		Foerster Rotor	
Decimal	Fractional	Metric	Unshielded	Shielded	Unshielded	Shielded
0.125 in.	1/8 in.	3.17 mm	BPU-8	N/A	BPD-8	N/A
0.156 in.	5/32 in.	3.96 mm	BPU-10	BPUF-10	BPD-10	BPDF-10
		4 mm	BPU-4.0M	BPUF-4.0M	BPD-4.0M	BPDF-4.0M
0.187 in.	3/16 in.	4.75 mm	BPU-12	BPUF-12	BPD-12	BPDF-12
		5 mm	BPU-5.0M	BPUF-5.0M	BPD-5.0M	BPDF-5.0M
		6 mm	BPU-6.0M	BPUF-6.0M	BPD-6.0M	BPDF-6.0M
0.250 in.	1/4 in.	6.34 mm	BPU-16	BPUF-16	BPD-16	BPDF-16
		7 mm	BPU-7.0M	BPUF-7.0M	BPD-7.0M	BPDF-7.0M
0.312 in.	5/16 in.	7.92 mm	BPU-20	BPUF-20	BPD-20	BPDF-20
		9 mm	BPU-9.0M	BPUF-9.0M	BPD-9.0M	BPDF-9.0M
0.375 in.	3/8 in.	9.52 mm	BPU-24	BPUF-24	BPD-24	BPDF-24
		11 mm	BPU-11.0M	BPUF-11.0M	BPD-11.0M	BPDF-11.0M
0.437 in.	7/16 in.	11.09 mm	BPU-28	BPUF-28	BPD-28	BPDF-28
0.500 in.	1/2 in.	12.69 mm	BPU-32	BPUF-32	BPD-32	BPDF-32
		13 mm	BPU-13.0M	BPUF-13.0M	BPD-13.0M	BPDF-13.0M
0.562 in.	9/16 in.	14.26 mm	BPU-36	BPUF-36	BPD-36	BPDF-36
		15 mm	BPU-15.0M	BPUF-15.0M	BPD-15.0M	BPDF-15.0M
0.625 in.	5/8 in.	15.86 mm	BPU-40	BPUF-40	BPD-40	BPDF-40
0.687 in.	11/16 in.	17.44 mm	BPU-44	BPUF-44	BPD-44	BPDF-44
0.750 in.	3/4 in.	19.03 mm	BPU-48	BPUF-48	BPD-48	BPDF-48

The universal rotor is suitable for the following rotary guns: Hocking mini drive, Rohmann mini-rotor, Nortec MiniMite (with 4-pin Fischer) and Spitfire 2000, Uniwest HRO scanner and Zetec ZS-4 high speed scanner.

Nortec Rechii Rotor

RA 19, RA 2000, or MiniMite (with 4-pin LEMO)

Nortec PS5 Rotor

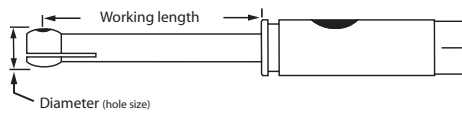
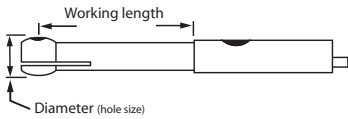

Options

Add to end of part number if other than standard	/SE: spread end
	/SS: stainless steel
	/x.xWL: working length
	/x.xOAL: overall length

Hole size			Nortec Rechii Rotor		Nortec PS5 Rotor	
Decimal	Fractional	Metric	Unshielded	Shielded	Unshielded	Shielded
0.125 in.	1/8 in.	3.17 mm	BPRA-8	N/A	PS5-8	N/A
0.156 in.	5/32 in.	3.96 mm	BPRA-10	BPRAF-10	PS5-10	PS5F-10
		4 mm	BPRA-4.0M	BPRAF-4.0M	PS5-4.0M	PS5F-4.0M
0.187 in.	3/16 in.	4.75 mm	BPRA-12	BPRAF-12	PS5-12	PS5F-12
		5 mm	BPRA-5.0M	BPRAF-5.0M	PS5-5.0M	PS5F-5.0M
		6 mm	BPRA-6.0M	BPRAF-6.0M	PS5-6.0M	PS5F-6.0M
0.250 in.	1/4 in.	6.34 mm	BPRA-16	BPRAF-16	PS5-16	PS5F-16
		7 mm	BPRA-7.0M	BPRAF-7.0M	PS5-7.0M	PS5F-7.0M
0.312 in.	5/16 in.	7.92 mm	BPRA-20	BPRAF-20	PS5-20	PS5F-20
		9 mm	BPRA-9.0M	BPRAF-9.0M	PS5-9.0M	PS5F-9.0M
0.375 in.	3/8 in.	9.52 mm	BPRA-24	BPRAF-24	PS5-24	PS5F-24
		11 mm	BPRA-11.0M	BPRAF-11.0M	PS5-11.0M	PS5F-11.0M
0.437 in.	7/16 in.	11.09 mm	BPRA-28	BPRAF-28	PS5-28	PS5F-28
0.500 in.	1/2 in.	12.69 mm	BPRA-32	BPRAF-32	PS5-32	PS5F-32
		13 mm	BPRA-13.0M	BPRAF-13.0M	PS5-13.0M	PS5F-13.0M
0.562 in.	9/16 in.	14.26 mm	BPRA-36	BPRAF-36	PS5-36	PS5F-36
		15 mm	BPRA-15.0M	BPRAF-15.0M	PS5-15.0M	PS5F-15.0M
0.625 in.	5/8 in.	15.86 mm	BPRA-40	BPRAF-40	PS5-40	PS5F-40
0.687 in.	11/16 in.	17.44 mm	BPRA-44	BPRAF-44	PS5-44	PS5F-44
0.750 in.	3/4 in.	19.03 mm	BPRA-48	BPRAF-48	PS5-48	PS5F-48



Zetec® Rotor

Standard Configuration

Zetec Rotor

- Frequency: see chart
- Black plastic body

Next Page

Elotest Standard Rotor

- 100 kHz–2 MHz
- Black plastic body

Elotest Mini Rotor

- 100 kHz–2 MHz
- Black plastic body

Working length is per the following table:

Size range	WL
8–15	1.1 in.
16–64	2.0 in.

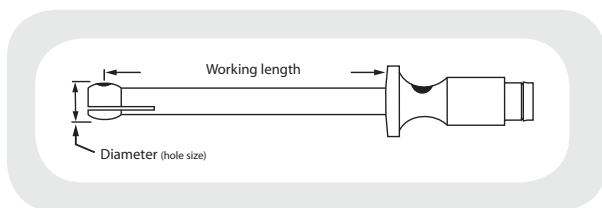

Options

Add to end of part number if other than standard	/SE: spread end /SS: stainless steel /x.xWL: working length /x.xOAL: overall length
--	--

Standard frequency

Absolute probe:	50 kHz–500 kHz
Differential probe:	300 kHz–1 MHz

Hole size			Zetec Rotor			
			Absolute		Differential	
Decimal	Fractional	Metric	Unshielded	Shielded	Unshielded	Shielded
0.125 in.	1/8 in.	3.17 mm	BPZ 8	N/A	BZD-8	N/A
0.156 in.	5/32 in.	3.96 mm	BPZ-10	BPZF-10	BZD-10	BZDF-10
		4 mm	BPZ-4.0M	BPZF-4.0M	BZD-4.0M	BZDF-4.0M
0.187 in.	3/16 in.	4.75 mm	BPZ-12	BPZF-12	BZD-12	BZDF-12
		5 mm	BPZ-5.0M	BPZF-5.0M	BZD-5.0M	BZDF-5.0M
		6 mm	BPZ-6.0M	BPZF-6.0M	BZD-6.0M	BZDF-6.0M
0.250 in.	1/4 in.	6.34 mm	BPZ-16	BPZF-16	BZD-16	BZDF-16
		7 mm	BPZ-7.0M	BPZF-7.0M	BZD-7.0M	BZDF-7.0M
0.312 in.	5/16 in.	7.92 mm	BPZ-20	BPZF-20	BZD-20	BZDF-20
		9 mm	BPZ-9.0M	BPZF-9.0M	BZD-9.0M	BZDF-9.0M
0.375 in.	3/8 in.	9.52 mm	BPZ-24	BPZF-24	BZD-24	BZDF-24
		11 mm	BPZ-11.0M	BPZF-11.0M	BZD-11.0M	BZDF-11.0M
0.437 in.	7/16 in.	11.09 mm	BPZ-28	BPZF-28	BZD-28	BZDF-28
0.500 in.	1/2 in.	12.69 mm	BPZ-32	BPZF-32	BZD-32	BZDF-32
		13 mm	BPZ-13.0M	BPZF-13.0M	BZD-13.0M	BZDF-13.0M
0.562 in.	9/16 in.	14.26 mm	BPZ-36	BPZF-36	BZD-36	BZDF-36
		15 mm	BPZ-15.0M	BPZF-15.0M	BZD-15.0M	BZDF-15.0M
0.625 in.	5/8 in.	15.86 mm	BPZ-40	BPZF-40	BZD-40	BZDF-40
0.687 in.	11/16 in.	17.44 mm	BPZ-44	BPZF-44	BZD-44	BZDF-44
0.750 in.	3/4 in.	19.03 mm	BPZ-48	BPZF-48	BZD-48	BZDF-48

Elotest Standard Rotor

Rohmann SR1, SR2



Elotest Mini Rotor

Rohmann SMR4, MR3

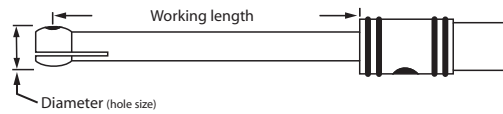
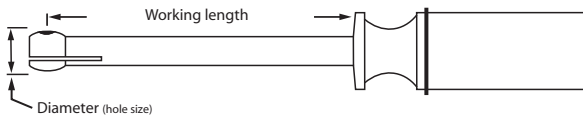

Options

Add to end of part number if other than standard

/SE: spread end
 /SS: stainless steel
 /x.xWL: working length
 /x.xOAL: overall length

Hole size			Elotest Standard Rotor		Elotest Mini Rotor	
Decimal	Fractional	Metric	Unshielded	Shielded	Unshielded	Shielded
0.125 in.	1/8 in.	3.17 mm	BPE-8	N/A	BPEM-8	N/A
0.156 in.	5/32 in.	3.96 mm	BPE-10	BPEF-10	BPEM-10	BPEMF-10
		4 mm	BPE-4.0M	BPEF-4.0M	BPEM-4.0M	BPEMF-4.0M
0.187 in.	3/16 in.	4.75 mm	BPE-12	BPEF-12	BPEM-12	BPEMF-12
		5 mm	BPE-5.0M	BPEF-5.0M	BPEM-5.0M	BPEMF-5.0M
		6 mm	BPE-6.0M	BPEF-6.0M	BPEM-6.0M	BPEMF-6.0M
0.250 in.	1/4 in.	6.34 mm	BPE-16	BPEF-16	BPEM-16	BPEMF-16
		7 mm	BPE-7.0M	BPEF-7.0M	BPEM-7.0M	BPEMF-7.0M
0.312 in.	5/16 in.	7.92 mm	BPE-20	BPEF-20	BPEM-20	BPEMF-20
		9 mm	BPE-9.0M	BPEF-9.0M	BPEM-9.0M	BPEMF-9.0M
0.375 in.	3/8 in.	9.52 mm	BPE-24	BPEF-24	BPEM-24	BPEMF-24
		11 mm	BPE-11.0M	BPEF-11.0M	BPEM-11.0M	BPEMF-11.0M
0.437 in.	7/16 in.	11.09 mm	BPE-28	BPEF-28	BPEM-28	BPEMF-28
0.500 in.	1/2 in.	12.69 mm	BPE-32	BPEF-32	BPEM-32	BPEMF-32
		13 mm	BPE-13.0M	BPEF-13.0M	BPEM-13.0M	BPEMF-13.0M
0.562 in.	9/16 in.	14.26 mm	BPE-36	BPEF-36	BPEM-36	BPEMF-36
		15 mm	BPE-15.0M	BPEF-15.0M	BPEM-15.0M	BPEMF-15.0M
0.625 in.	5/8 in.	15.86 mm	BPE-40	BPEF-40	BPEM-40	BPEMF-40
0.687 in.	11/16 in.	17.44 mm	BPE-44	BPEF-44	BPEM-44	BPEMF-44
0.750 in.	3/4 in.	19.03 mm	BPE-48	BPEF-48	BPEM-48	BPEMF-48



Rotary Countersink

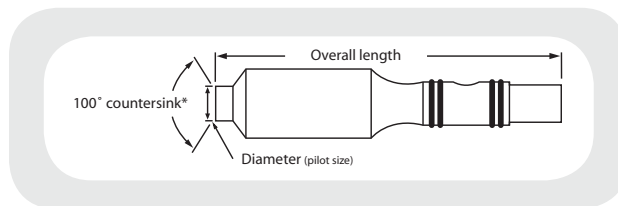

Options

Add to end of part number if other than standard	/SS: stainless steel /x.xWL: working length /x.xOAL: overall length
* Other angles are available by replacing the "100" with the required countersink angle in the part number	

Overall length

Universal rotor: 2.5 in.
Mini rotor: 2.125 in.
Zetec rotor: 2.225 in.
Rechii rotor: 2.0 in.
Foerster rotor: 2.2 in.

Hole size			Universal Rotor	Elotest Mini Rotor	Zetec Rotor	Rechii Rotor
Decimal	Fractional	Metric				
0.125 in.	1/8 in.	3.17 mm	CSU100-8	CSEM100-8	CSZ100-8	CSRA100-8
0.156 in.	5/32 in.	3.96 mm	CSU100-10	CSEM100-10	CSZ100-10	CSRA100-10
		4 mm	CSU100-4.0M	CSEM100-4.0M	CSZ100-4.0M	CSRA100-4.0M
0.187 in.	3/16 in.	4.75 mm	CSU100-12	CSEM100-12	CSZ100-12	CSRA100-12
		5 mm	CSU100-5.0M	CSEM100-5.0M	CSZ100-5.0M	CSRA100-5.0M
		6 mm	CSU100-6.0M	CSEM100-6.0M	CSZ100-6.0M	CSRA100-6.0M
0.250 in.	1/4 in.	6.34 mm	CSU100-16	CSEM100-16	CSZ100-16	CSRA100-16
		7 mm	CSU100-7.0M	CSEM100-7.0M	CSZ100-7.0M	CSRA100-7.0M
0.312 in.	5/16 in.	7.92 mm	CSU100-20	CSEM100-20	CSZ100-20	CSRA100-20
		9 mm	CSU100-9.0M	CSEM100-9.0M	CSZ100-9.0M	CSRA100-9.0M
0.375 in.	3/8 in.	9.52 mm	CSU100-24	CSEM100-24	CSZ100-24	CSRA100-24
		11 mm	CSU100-11.0M	CSEM100-11.0M	CSZ100-11.0M	CSRA100-11.0M
0.437 in.	7/16 in.	11.09 mm	CSU100-28	CSEM100-28	CSZ100-28	CSRA100-28
0.500 in.	1/2 in.	12.69 mm	CSU100-32	CSEM100-32	CSZ100-32	CSRA100-32
		13 mm	CSU100-13.0M	CSEM100-13.0M	CSZ100-13.0M	CSRA100-13.0M
0.562 in.	9/16 in.	14.26 mm	CSU100-36	CSEM100-36	CSZ100-36	CSRA100-36
		15 mm	CSU100-15.0M	CSEM100-15.0M	CSZ100-15.0M	CSRA100-15.0M
0.625 in.	5/8 in.	15.86 mm	CSU100-40	CSEM100-40	CSZ100-40	CSRA100-40
0.687 in.	11/16 in.	17.44 mm	CSU100-44	CSEM100-44	CSZ100-44	CSRA100-44
0.750 in.	3/4 in.	19.03 mm	CSU100-48	CSEM100-48	CSZ100-48	CSRA100-48

Manual Standard

Standard Configuration

Manual Standard
(Compatible with Hocking locator at 200 kHz)

- 50 kHz–500 kHz, 200 kHz center frequency
- Black plastic body

Next Page

Manual Countersink

- 100° Countersink
- 2 in. overall length
- 50 kHz–500 kHz
- Black plastic body

Manual for Locator UHB

- 500 kHz or 6 MHz
- Black plastic body

* Working length is per the following table:

Size range	WL
8–15	1.1 in.
16–64	2.0 in.

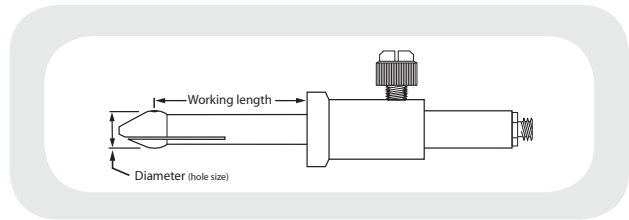

Options

Add to end of part number if other than standard	/200K-1M, /1-3M: frequency /x.xWL: working length /x.xOAL: overall length
--	---

Hole size			Manual Standard			
Decimal	Fractional	Metric	50–500 kHz		200 kHz–1 MHz	
			Unshielded	Shielded	Unshielded	Shielded
0.125 in.	1/8 in.	3.17 mm	BPM-8	N/A	BPM-8/200K-1M	N/A
0.156 in.	5/32 in.	3.96 mm	BPM-10	BPMF-10	BPM-10/200K-1M	BPMF-10/200K-1M
		4 mm	BPM-4.0M	BPMF-4.0M	BPM-4.0M/200K-1M	BPMF-4.0M/200K-1M
0.187 in.	3/16 in.	4.75 mm	BPM-12	BPMF-12	BPM-12/200K-1M	BPMF-12/200K-1M
		5 mm	BPM-5.0M	BPMF-5.0M	BPM-5.0M/200K-1M	BPMF-5.0M/200K-1M
		6 mm	BPM-6.0M	BPMF-6.0M	BPM-6.0M/200K-1M	BPMF-6.0M/200K-1M
0.250 in.	1/4 in.	6.34 mm	BPM-16	BPMF-16	BPM-16/200K-1M	BPMF-16/200K-1M
		7 mm	BPM-7.0M	BPMF-7.0M	BPM-7.0M/200K-1M	BPMF-7.0M/200K-1M
0.312 in.	5/16 in.	7.92 mm	BPM-20	BPMF-20	BPM-20/200K-1M	BPMF-20/200K-1M
		9 mm	BPM-9.0M	BPMF-9.0M	BPM-9.0M/200K-1M	BPMF-9.0M/200K-1M
0.375 in.	3/8 in.	9.52 mm	BPM-24	BPMF-24	BPM-24/200K-1M	BPMF-24/200K-1M
		11 mm	BPM-11.0M	BPMF-11.0M	BPM-11.0M/200K-1M	BPMF-11.0M/200K-1M
0.437 in.	7/16 in.	11.09 mm	BPM-28	BPMF-28	BPM-28/200K-1M	BPMF-28/200K-1M
0.500 in.	1/2 in.	12.69 mm	BPM-32	BPMF-32	BPM-32/200K-1M	BPMF-32/200K-1M
		13 mm	BPM-13.0M	BPMF-13.0M	BPM-13.0M/200K-1M	BPMF-13.0M/200K-1M
0.562 in.	9/16 in.	14.26 mm	BPM-36	BPMF-36	BPM-36/200K-1M	BPMF-36/200K-1M
		15 mm	BPM-15.0M	BPMF-15.0M	BPM-15.0M/200K-1M	BPMF-15.0M/200K-1M
0.625 in.	5/8 in.	15.86 mm	BPM-40	BPMF-40	BPM-40/200K-1M	BPMF-40/200K-1M
0.687 in.	11/16 in.	17.44 mm	BPM-44	BPMF-44	BPM-44/200K-1M	BPMF-44/200K-1M
0.750 in.	3/4 in.	19.03 mm	BPM-48	BPMF-48	BPM-48/200K-1M	BPMF-48/200K-1M



Manual Countersink

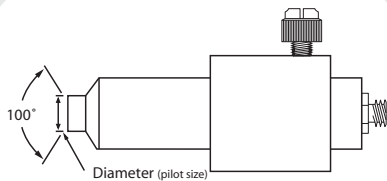

Options

Add to end of part number if other than standard /200K-1M, /1-3M: frequency

Manual for Locator UHB

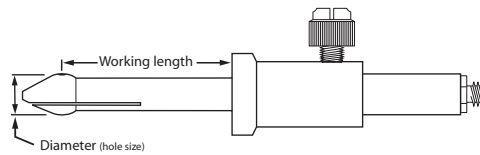

Options

Add to end of part number if other than standard /500K or /6M: frequency
/x.xWL: working length
/x.xOAL: overall length

Hole size			Manual Countersink		Manual for Locator UHB	
Decimal	Fractional	Metric	Unshielded	Shielded	Unshielded	Shielded
0.125 in.	1/8 in.	3.17 mm	CSM100-8	N/A	BLM-8/500K	N/A
0.156 in.	5/32 in.	3.96 mm	CSM100-10	CSMF100-10	BLM-10/500K	BLMF-10/500K
		4 mm	CSM100-4.0M	CSMF100-4.0M	BLM-4.0M/500K	BLMF-4.0M/500K
0.187 in.	3/16 in.	4.75 mm	CSM100-12	CSMF100-12	BLM-12/500K	BLMF-12/500K
		5 mm	CSM100-5.0M	CSMF100-5.0M	BLM-5.0M/500K	BLMF-5.0M/500K
		6 mm	CSM100-6.0M	CSMF100-6.0M	BLM-6.0M/500K	BLMF-6.0M/500K
0.250 in.	1/4 in.	6.34 mm	CSM100-16	CSMF100-16	BLM-16/500K	BLMF-16/500K
		7 mm	CSM100-7.0M	CSMF100-7.0M	BLM-7.0M/500K	BLMF-7.0M/500K
0.312 in.	5/16 in.	7.92 mm	CSM100-20	CSMF100-20	BLM-20/500K	BLMF-20/500K
		9 mm	CSM100-9.0M	CSMF100-9.0M	BLM-9.0M/500K	BLMF-9.0M/500K
0.375 in.	3/8 in.	9.52 mm	CSM100-24	CSMF100-24	BLM-24/500K	BLMF-24/500K
		11 mm	CSM100-11.0M	CSMF100-11.0M	BLM-11.0M/500K	BLMF-11.0M/500K
0.437 in.	7/16 in.	11.09 mm	CSM100-28	CSMF100-28	BLM-28/500K	BLMF-28/500K
0.500 in.	1/2 in.	12.69 mm	CSM100-32	CSMF100-32	BLM-32/500K	BLMF-32/500K
		13 mm	CSM100-13.0M	CSMF100-13.0M	BLM-13.0M/500K	BLMF-13.0M/500K
0.562 in.	9/16 in.	14.26 mm	CSM100-36	CSMF100-36	BLM-36/500K	BLMF-36/500K
		15 mm	CSM100-15.0M	CSMF100-15.0M	BLM-15.0M/500K	BLMF-15.0M/500K
0.625 in.	5/8 in.	15.86 mm	CSM100-40	CSMF100-40	BLM-40/500K	BLMF-40/500K
0.687 in.	11/16 in.	17.44 mm	CSM100-44	CSMF100-44	BLM-44/500K	BLMF-44/500K
0.750 in.	3/4 in.	19.03 mm	CSM100-48	CSMF100-48	BLM-48/500K	BLMF-48/500K

Adjustable Diameter

Standard Configuration

Standard Manual

- 50 kHz–500 kHz,
200 kHz center frequency
- Black plastic body

Universal Rotor

- 100 kHz–2 MHz
- Black plastic body

Next Page

X type adjustable

Working length on X type is per the following table:

Size range	WL
10/12–12/16	1.1 in.
16/20 and up	2.0 in.

Y type adjustable

Working length on Y type is per the following table:

Size range	WL
8/10	1.3 in.
10/12	1.3 in.
12/16–16/20	1.8 in.
20/24 and up	2.0 in.

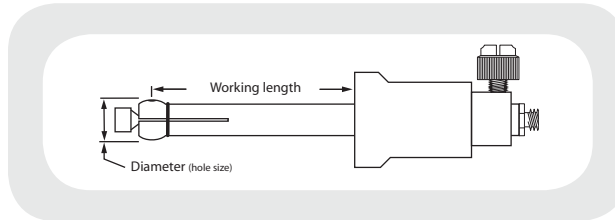

Drawings for this item are on next page

Options

Add to end of part number if other than standard
 /200K-1M, /1-3M: frequency
 /x.xWL: working length
 /x.xOAL: overall length

Range of Hole Sizes	Standard Manual		Universal Rotor	
	“X” Type	“Y” Type	“X” Type	“Y” Type
0.125 in.–0.156 in.	N/A	N/A	N/A	BYU-8/10
0.156 in.–0.187 in.	N/A	N/A	N/A	BYU-10/12
5 mm–6 mm	BXM-5M/6M	N/A	BXU-5M/6M	BYU-5M/6M
0.187 in.–0.250 in.	BXM-12/16	N/A	BXU-12/16	BYU-12/16
6 mm–8 mm	BXM-6M/8M	N/A	BXU-6M/8M	BYU-6M/8M
0.250 in.–0.312 in.	BXM-16/20	N/A	BXU-16/20	BYU-16/20
0.312 in.–0.375 in.	BXM-20/24	N/A	BXU-20/24	BYU-20/24
8 mm–10 mm	BXM-8M/10M	N/A	BXU-8M/10M	BYU-8M/10M
0.375 in.–0.437 in.	BXM-24/28	N/A	BXU-24/28	BYU-24/28
10 mm–12 mm	BXM-10M/12M	N/A	BXU-10M/12M	BYU-10M/12M
0.437 in.–0.500 in.	BXM-28/32	N/A	BXU-28/32	BYU-28/32
12 mm–15 mm	BXM-12M/15M	N/A	BXU-12M/15M	BYU-12M/15M
0.500 in.–0.625 in.	BXM-32/40	N/A	BXU-32/40	BYU-32/40
15 mm–18 mm	BXM-15M/18M	N/A	BXU-15M/18M	BYU-15M/18M
0.625 in.–0.750 in.	BXM-40/48	N/A	BXU-40/48	BYU-40/48
18 mm–21 mm	BXM-18M/21M	N/A	BXU-18M/21M	BYU-18M/21M
0.750 in.–0.825 in.	BXM-48/56	N/A	BXU-48/56	BYU-48/56
21 mm–24 mm	BXM-21M/24M	N/A	BXU-21M/24M	BYU-21M/24M
0.825 in.–1.0 in.	BXM-56/64	N/A	BXU-56/64	BYU-56/64



Adjustable Diameter



X Type Adjustable

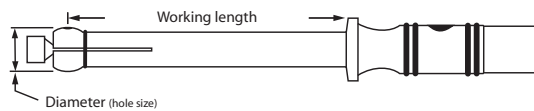

X probes have a thumbscrew that allows user to adjust coil away from rough-surface holes and is excellent for oversized holes.

Y Type Adjustable

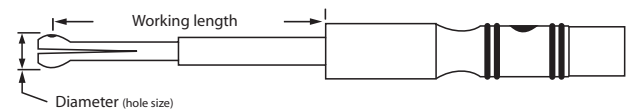

Y probes have an outer sleeve that allows user to inspect blind holes while taking advantage of a screw-type adjustment.

Options

Add to end of part number if other than standard	/x.xWL: working length /x.xOAL: overall length
--	---

Range of Hole Sizes	Foerster Rotor		Rechii Rotor		PS5 Rotor	
	"X" Type	"Y" Type	"X" Type	"Y" Type	"X" Type	"Y" Type
0.125 in.–0.156 in.	N/A	BYD-8/10	N/A	BYRA-8/10	N/A	PY5-8/10
0.156 in.–0.187 in.	N/A	BYD-10/12	N/A	BYRA-10/12	N/A	PY5-10/12
5 mm–6 mm	BXD-5M/6M	BYD-5M/6M	BXRA-5M/6M	BYRA-5M/6M	PX5-5M/6M	PY5-5M/6M
0.187 in.–0.250 in.	BXD-12/16	BYD-12/16	BXRA-12/16	BYRA-12/16	PX5-12/16	PY5-12/16
6 mm–8 mm	BXD-6M/8M	BYD-6M/8M	BXRA-6M/8M	BYRA-6M/8M	PX5-6M/8M	PY5-6M/8M
0.250 in.–0.312 in.	BXD-16/20	BYD-16/20	BXRA-16/20	BYRA-16/20	PX5-16/20	PY5-16/20
0.312 in.–0.375 in.	BXD-20/24	BYD-20/24	BXRA-20/24	BYRA-20/24	PX5-20/24	PY5-20/24
8 mm–10 mm	BXD-8M/10M	BYD-8M/10M	BXRA-8M/10M	BYRA-8M/10M	PX5-8M/10M	PY5-8M/10M
0.375 in.–0.437 in.	BXD-24/28	BYD-24/28	BXRA-24/28	BYRA-24/28	PX5-24/28	PY5-24/28
10 mm–12 mm	BXD-10M/12M	BYD-10M/12M	BXRA-10M/12M	BYRA-10M/12M	PX5-10M/12M	PY5-10M/12M
0.437 in.–0.500 in.	BXD-28/32	BYD-28/32	BXRA-28/32	BYRA-28/32	PX5-28/32	PY5-28/32
12 mm–15 mm	BXD-12M/15M	BYD-12M/15M	BXRA-12M/15M	BYRA-12M/15M	PX5-12M/15M	PY5-12M/15M
0.500 in.–0.625 in.	BXD-32/40	BYD-32/40	BXRA-32/40	BYRA-32/40	PX5-32/40	PY5-32/40
15 mm–18 mm	BXD-15M/18M	BYD-15M/18M	BXRA-15M/18M	BYRA-15M/18M	PX5-15M/18M	PY5-15M/18M
0.625 in.–0.750 in.	BXD-40/48	BYD-40/48	BXRA-40/48	BYRA-40/48	PX5-40/48	PY5-40/48
18 mm–21 mm	BXD-18M/21M	BYD-18M/21M	BXRA-18M/21M	BYRA-18M/21M	PX5-18M/21M	PY5-18M/21M
0.750 in.–0.825 in.	BXD-48/56	BYD-48/56	BXRA-48/56	BYRA-48/56	PX5-48/56	PY5-48/56
21 mm–24 mm	BXD-21M/24M	BYD-21M/24M	BXRA-21M/24M	BYRA-21M/24M	PX5-21M/24M	PY5-21M/24M
0.825 in.–1.0 in.	BXD-56/64	BYD-56/64	BXRA-56/64	BYRA-56/64	PX5-56/64	PY5-56/64

Adjustable Diameter

Standard Configuration

- 100 kHz–2 MHz
- Black plastic body

* Working length on X type is per the following table:

Size range	WL
10/12 - 12/16	1.1 in.
16/20 and up	2.0 in.

Next Page

Zetec Rotor

- 50–500 kHz/absolute
- 300 kHz–1 MHz/differential
- Black plastic body

PH Rotor

- 50 kHz–500 kHz
- Black plastic body

* Working length on Y type is per the following table:

Size range	WL
8/10	1.3 in.
10/12	1.3 in.
12/16–16/20	1.8 in.
20/24 and up	2.0 in.



X Type Adjustable

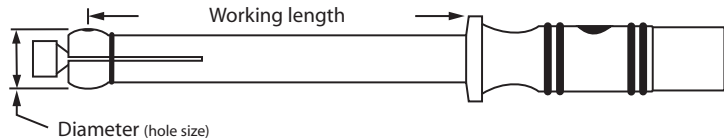

X probes have a thumbscrew that allows user to adjust coil away from rough-surface holes and is excellent for oversized holes.

Options

Add to end of part number if other than standard	/x.xWL: working length /x.xOAL: overall length
--	---

Range of Hole Sizes	Elotest Standard Rotor		Elotest Mini Rotor	
	"X" Type	"Y" Type	"X" Type	"Y" Type
0.125 in.–0.156 in.	N/A	BYE-8/10	N/A	BYEM-8/10
0.156 in.–0.187 in.	N/A	BYE-10/12	N/A	BYEM-10/12
5 mm–6 mm	BXE-5M/6M	BYE-5M/6M	BXEM-5M/6M	BYEM-5M/6M
0.187 in.–0.250 in.	BXE-12/16	BYE-12/16	BXEM-12/16	BYEM-12/16
6 mm–8 mm	BXE-6M/8M	BYE-6M/8M	BXEM-6M/8M	BYEM-6M/8M
0.250 in.–0.312 in.	BXE-16/20	BYE-16/20	BXEM-16/20	BYEM-16/20
0.312 in.–0.375 in.	BXE-20/24	BYE-20/24	BXEM-20/24	BYEM-20/24
8 mm–10 mm	BXE-8M/10M	BYE-8M/10M	BXEM-8M/10M	BYEM-8M/10M
0.375 in.–0.437 in.	BXE-24/28	BYE-24/28	BXEM-24/28	BYEM-24/28
10 mm–12 mm	BXE-10M/12M	BYE-10M/12M	BXEM-10M/12M	BYEM-10M/12M
0.437 in.–0.500 in.	BXE-28/32	BYE-28/32	BXEM-28/32	BYEM-28/32
12 mm–15 mm	BXE-12M/15M	BYE-12M/15M	BXEM-12M/15M	BYEM-12M/15M
0.500 in.–0.625 in.	BXE-32/40	BYE-32/40	BXEM-32/40	BYEM-32/40
15 mm–18 mm	BXE-15M/18M	BYE-15M/18M	BXEM-15M/18M	BYEM-15M/18M
0.625 in.–0.750 in.	BXE-40/48	BYE-40/48	BXEM-40/48	BYEM-40/48
18 mm–21 mm	BXE-18M/21M	BYE-18M/21M	BXEM-18M/21M	BYEM-18M/21M
0.750 in.–0.825 in.	BXE-48/56	BYE-48/56	BXEM-48/56	BYEM-48/56
21 mm–24 mm	BXE-21M/24M	BYE-21M/24M	BXEM-21M/24M	BYEM-21M/24M
0.825 in.–1.0 in.	BXE-56/64	BYE-56/64	BXEM-56/64	BYEM-56/64



Adjustable Diameter

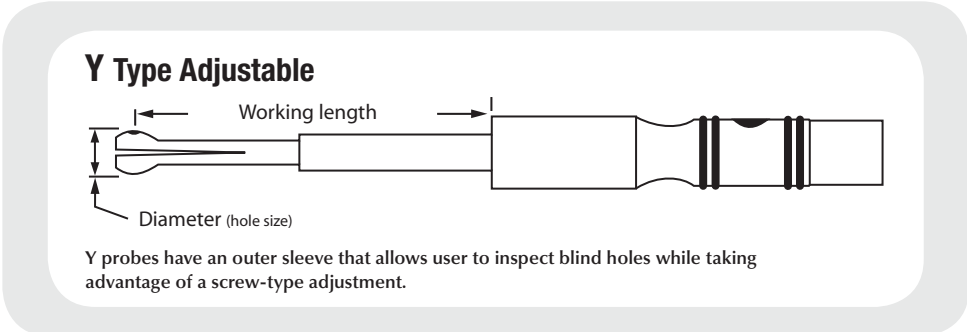

Options

Add to end of part number if other than standard

/x.xWL: working length
/x.xOAL: overall length

Range of Hole Sizes	Zetec rotor			Physical Acoustics Rotor		
	Absolute "X" Type	Absolute "Y" Type	Differential "X" Type	Absolute "X" Type	Absolute "Y" Type	Differential "X" Type
0.125 in.–0.156 in.	N/A	BYZ-8/10	N/A	N/A	BYA-8/10	N/A
0.156 in.–0.187 in.	N/A	BYZ-10/12	N/A	N/A	BYA-10/12	N/A
5 mm–6 mm	BXZ-5M/6M	BYZ-5M/6M	BXZD-5M/6M	BXA-5M/6M	BYA-5M/6M	BXAD-5M/6M
0.187 in.–0.250 in.	BXZ-12/16	BYZ-12/16	BXZD-12/16	BXA-12/16	BYA-12/16	BXAD-12/16
6 mm–8 mm	BXZ-6M/8M	BYZ-6M/8M	BXZD-6M/8M	BXA-6M/8M	BYA-6M/8M	BXAD-6M/8M
0.250 in.–0.312 in.	BXZ-16/20	BYZ-16/20	BXZD-16/20	BXA-16/20	BYA-16/20	BXAD-16/20
0.312 in.–0.375 in.	BXZ-20/24	BYZ-20/24	BXZD-20/24	BXA-20/24	BYA-20/24	BXAD-20/24
8 mm–10 mm	BXZ-8M/10M	BYZ-8M/10M	BXZD-8M/10M	BXA-8M/10M	BYA-8M/10M	BXAD-8M/10M
0.375 in.–0.437 in.	BXZ-24/28	BYZ-24/28	BXZD-24/28	BXA-24/28	BYA-24/28	BXAD-24/28
10 mm–12 mm	BXZ-10M/12M	BYZ-10M/12M	BXZD-10M/12M	BXA-10M/12M	BYA-10M/12M	BXAD-10M/12M
0.437 in.–0.500 in.	BXZ-28/32	BYZ-28/32	BXZD-28/32	BXA-28/32	BYA-28/32	BXAD-28/32
12 mm–15 mm	BXZ-12M/15M	BYZ-12M/15M	BXZD-12M/15M	BXA-12M/15M	BYA-12M/15M	BXAD-12M/15M
0.500 in.–0.625 in.	BXZ-32/40	BYZ-32/40	BXZD-32/40	BXA-32/40	BYA-32/40	BXAD-32/40
15 mm–18 mm	BXZ-15M/18M	BYZ-15M/18M	BXZD-15M/18M	BXA-15M/18M	BYA-15M/18M	BXAD-15M/18M
0.625 in.–0.750 in.	BXZ-40/48	BYZ-40/48	BXZD-40/48	BXA-40/48	BYA-40/48	BXAD-40/48
18 mm–21 mm	BXZ-18M/21M	BYZ-18M/21M	BXZD-18M/21M	BXA-18M/21M	BYA-18M/21M	BXAD-18M/21M
0.750 in.–0.825 in.	BXZ-48/56	BYZ-48/56	BXZD-48/56	BXA-48/56	BYA-48/56	BXAD-48/56
21 mm–24 mm	BXZ-21M/24M	BYZ-21M/24M	BXZD-21M/24M	BXA-21M/24M	BYA-21M/24M	BXAD-21M/24M
0.825 in.–1.0 in.	BXZ-56/64	BYZ-56/64	BXZD-56/64	BXA-56/64	BYA-56/64	BXAD-56/64

Surface Probes

Straight - Microdot Straight - Fischer® Triax

Standard Configuration

With Microdot (Threaded)

- No balance coil
- 50 kHz–500 kHz,
200 kHz center frequency
- Stainless steel shaft
- Black plastic handle

With Fischer® Triax (Quick disconnect)

- With balance coil
- 50 kHz–500 kHz,
200 kHz center frequency
- Stainless steel shaft
- Black plastic handle



Next Page

With Microdot (Threaded)

- No balance coil
- 50 kHz–500 kHz
- Stainless steel shaft
- Black plastic handle

With Fischer® Triax (Quick disconnect)

- With balance coil
- 50 kHz–500 kHz
- Stainless steel shaft
- Black plastic handle

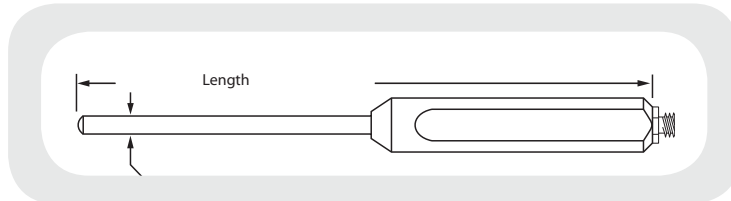

Options

Add to end of part number if other than standard	FX: flexible copper shaft
	/200K-1M, /1-3M: frequency (MP) /200K-1M, /1-6M: frequency (MTF)

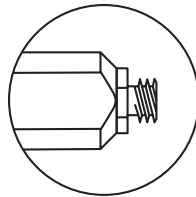

Microdot connector

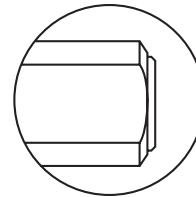

Fischer triax connector

Probe length		Straight with Microdot		Straight with Fischer Triax	
		1/8 in. Shielded	1/8 in. Unshielded	1/8 in. Shielded	1/8 in. Unshielded
1.0 in.	-10	MP-10	UMP-10	--	--
2.0 in.	-20	MP-20	UMP-20	MTF-20	UMTF-20
3.0 in.	-30	MP-30	UMP-30	MTF-30	UMTF-30
4.0 in.	-40	MP-40	UMP-40	MTF-40	UMTF-40
5.0 in.	-50	MP-50	UMP-50	MTF-50	UMTF-50
6.0 in.	-60	MP-60	UMP-60	MTF-60	UMTF-60
7.0 in.	-70	MP-70	UMP-70	MTF-70	UMTF-70
8.0 in.	-80	MP-80	UMP-80	MTF-80	UMTF-80
9.0 in.	-90	MP-90	UMP-90	MTF-90	UMTF-90
10.0 in.	-100	MP-100	UMP-100	MTF-100	UMTF-100
11.0 in.	-110	MP-110	UMP-110	MTF-110	UMTF-110
12.0 in.	-120	MP-120	UMP-120	MTF-120	UMTF-120



Straight - Microtip



Straight - Plastic Tip

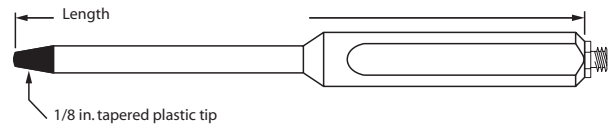
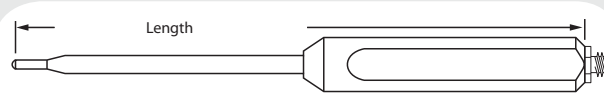

Options

Add to end of part number if other than standard	FX: flexible copper shaft /200K-1M, /1-3M: frequency
--	---

Options

Add to end of part number if other than standard	/200K-1M, /1-3M: frequency (UP) /200K-1M, /1-6M: frequency (UTF)
--	---

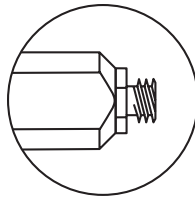

Microdot connector

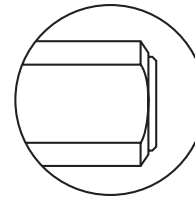

Fischer triax connector

Probe length		Straight - Microtip		Straight - Plastic Tip	
		Microdot	Fischer Triax	Microdot	Fischer Triax
1.0 in.	-10	MMP-10	--	UP-10	--
2.0 in.	-20	MMP-20	MMTF-20	UP-20	UTF-20
3.0 in.	-30	MMP-30	MMTF-30	UP-30	UTF-30
4.0 in.	-40	MMP-40	MMTF-40	UP-40	UTF-40
5.0 in.	-50	MMP-50	MMTF-50	UP-50	UTF-50
6.0 in.	-60	MMP-60	MMTF-60	UP-60	UTF-60
7.0 in.	-70	MMP-70	MMTF-70	UP-70	UTF-70
8.0 in.	-80	MMP-80	MMTF-80	UP-80	UTF-80
9.0 in.	-90	MMP-90	MMTF-90	UP-90	UTF-90
10.0 in.	-100	MMP-100	MMTF-100	UP-100	UTF-100
11.0 in.	-110	MMP-110	MMTF-110	UP-110	UTF-110
12.0 in.	-120	MMP-120	MMTF-120	UP-120	UTF-120

Right Angle Tip 0.5 in. Drop

Standard Configuration

With Microdot (Threaded)

- No balance coil
- 50 kHz–500 kHz
200 kHz center frequency
- Stainless steel shaft
- Black plastic handle

With Fischer® Triax (Quick disconnect)

- With balance coil
- 50 kHz–500 kHz
- Stainless steel shaft
- Black plastic handle

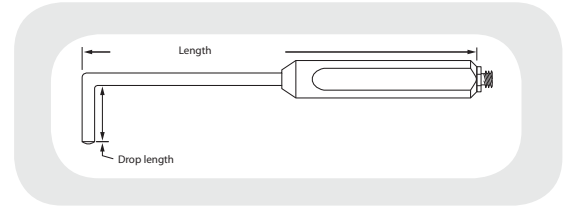

Unshielded surface probes are configured by adding a U to the front of most surface probe part number.
Example: UMP905-30

Options

Add to end of part number if other than standard

- B: bent handle
- C: curved angle drop (0.3 in. or greater)
- FX: flexible copper shaft
- /200K-1M, /1-3M: frequency (MP)
- /200K-1M, /1-6M: frequency (MTF)

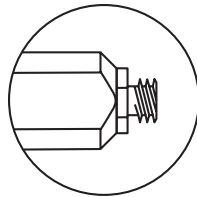

Microdot connector

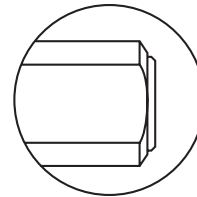

Fischer triax connector

Probe Length		Right Angle Tip 0.5 in. Drop with Microdot		Right Angle Tip 0.5 in. Drop with Fischer Triax	
		1/8 in. Shielded	0.072 in. Shielded	1/8 in. Shielded	0.072 in. Shielded
3.0 in.	-30	MP905-30	MMP905-30	MTF905-30	MMTF905-30
4.0 in.	-40	MP905-40	MMP905-40	MTF905-40	MMTF905-40
4.5 in.	-45	MP905-45	MMP905-45	MTF905-45	MMTF905-45
5.0 in.	-50	MP905-50	MMP905-50	MTF905-50	MMTF905-50
6.0 in.	-60	MP905-60	MMP905-60	MTF905-60	MMTF905-60
6.5 in.	-65	MP905-65	MMP905-65	MTF905-65	MMTF905-65
7.0 in.	-70	MP905-70	MMP905-70	MTF905-70	MMTF905-70
8.0 in.	-80	MP905-80	MMP905-80	MTF905-80	MMTF905-80
9.0 in.	-90	MP905-90	MMP905-90	MTF905-90	MMTF905-90
10.0 in.	-100	MP905-100	MMP905-100	MTF905-100	MMTF905-100
11.0 in.	-110	MP905-110	MMP905-110	MTF905-110	MMTF905-110
12.0 in.	-120	MP905-120	MMP905-120	MTF905-120	MMTF905-120



Right Angle Tip 0.2 in. Drop



Right Angle Tip 0.03 in. Drop

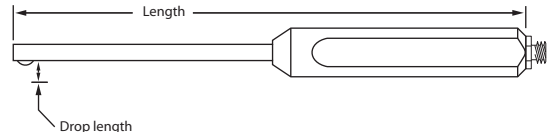
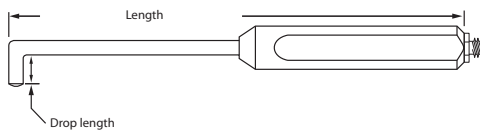

Options

Add to end of part number if other than standard

- B: bent handle
- C: curved angle drop (0.3 in. or greater)
- FX: flexible copper shaft
- /200K-1M, /1-3M: frequency (MP)
- /200K-1M, /1-6M: frequency (MTF)

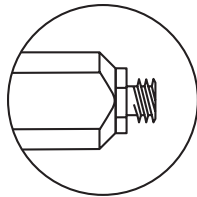

Microdot connector

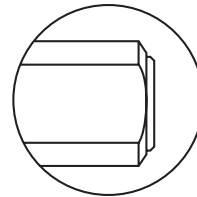

Fischer triax connector

Probe Length		Right Angle Tip 0.2 in. Drop with Microdot		Right Angle Tip 0.2 in. Drop with Fischer Triax		Right Angle Tip 0.03 in. Drop	
		1/8 in. Shielded	1/16 in. Shielded	1/8 in. Shielded	1/16 in. Shielded	Microdot 1/8 in. Shielded	Fischer Triax 1/8 in. Shielded
3.0 in.	-30	MP902-30	MMP902-30	MTF902-30	MMTF902-30	MP9003-30	MTF9003-30
4.0 in.	-40	MP902-40	MMP902-40	MTF902-40	MMTF902-40	MP9003-40	MTF9003-40
4.5 in.	-45	MP902-45	MMP902-45	MTF902-45	MMTF902-45	MP9003-45	MTF9003-45
5.0 in.	-50	MP902-50	MMP902-50	MTF902-50	MMTF902-50	MP9003-50	MTF9003-50
6.0 in.	-60	MP902-60	MMP902-60	MTF902-60	MMTF902-60	MP9003-60	MTF9003-60
6.5 in.	-65	MP902-65	MMP902-65	MTF902-65	MMTF902-65	MP9003-65	MTF9003-65
7.0 in.	-70	MP902-70	MMP902-70	MTF902-70	MMTF902-70	MP9003-70	MTF9003-70
8.0 in.	-80	MP902-80	MMP902-80	MTF902-80	MMTF902-80	MP9003-80	MTF9003-80
9.0 in.	-90	MP902-90	MMP902-90	MTF902-90	MMTF902-90	MP9003-90	MTF9003-90
10.0 in.	-100	MP902-100	MMP902-100	MTF902-100	MMTF902-100	MP9003-100	MTF9003-100
11.0 in.	-110	MP902-110	MMP902-110	MTF902-110	MMTF902-110	MP9003-110	MTF9003-110
12.0 in.	-120	MP902-120	MMP902-120	MTF902-120	MMTF902-120	MP9003-120	MTF9003-120

45° Tip (0.5 in. Drop)

45° Tip (0.3 in. Drop)

Standard Configuration

With Microdot (Threaded)

- No balance coil
- 50 kHz–500 kHz
- Stainless steel shaft
- Black plastic handle

With Fischer® Triax (Quick disconnect)

- With balance coil
- 50 kHz–500 kHz
- Stainless steel shaft
- Black plastic handle

Next Page

With Microdot (Threaded)

- No balance coil
- 50 kHz–500 kHz
- Stainless steel shaft
- Black plastic handle

With Fischer® Triax (Quick disconnect)

- With balance coil
- 50 kHz–500 kHz
- Stainless steel shaft
- Black plastic handle

Unshielded surface probes are configured by adding a U to the front of any surface probe part number.

Example: UMP905-30

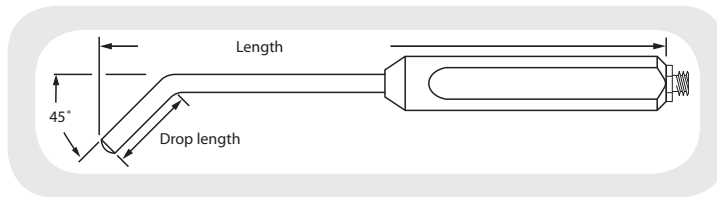

Options

Add to end of part number if other than standard

B: bent handle

C: curved angle drop (0.3 in. or greater)

FX: flexible copper shaft

/200K-1M, /1-3M: frequency (MP)

/200K-1M, /1-6M: frequency (MTF)

Note: probes pictured on this page have the curved option

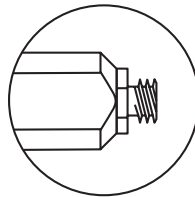

Microdot connector

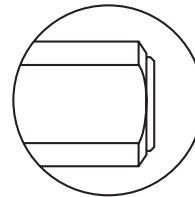

Fischer triax connector

Probe Length		45° Tip 0.5 in. Drop		45° Tip 0.3 in. Drop	
		Microdot	Fischer Triax	Microdot	Fischer Triax
		1/8 in. Shielded	1/8 in. Shielded	1/8 in. Shielded	1/8 in. Shielded
3.0 in.	-30	MP455-30	MTF455-30	MP453-30	MTF453-30
4.0 in.	-40	MP455-40	MTF455-40	MP453-40	MTF453-40
4.5 in.	-45	MP455-45	MTF455-45	MP453-45	MTF453-45
5.0 in.	-50	MP455-50	MTF455-50	MP453-50	MTF453-50
6.0 in.	-60	MP455-60	MTF455-60	MP453-60	MTF453-60
6.5 in.	-65	MP455-65	MTF455-65	MP453-65	MTF453-65
7.0 in.	-70	MP455-70	MTF455-70	MP453-70	MTF453-70
8.0 in.	-80	MP455-80	MTF455-80	MP453-80	MTF453-80
9.0 in.	-90	MP455-90	MTF455-90	MP453-90	MTF453-90
10.0 in.	-100	MP455-100	MTF455-100	MP453-100	MTF453-100
11.0 in.	-110	MP455-110	MTF455-110	MP453-110	MTF453-110
12.0 in.	-120	MP455-120	MTF455-120	MP453-120	MTF453-120



30° Tip (0.5 in. Drop)

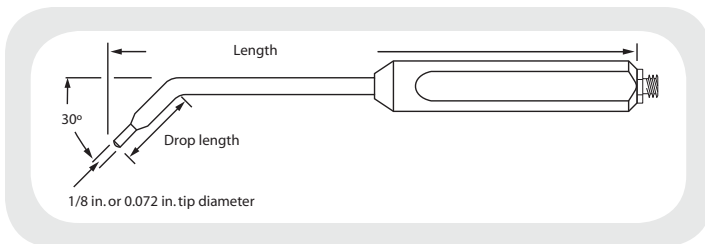

Options

Add to end of part number if other than standard

- B: bent handle
- C: curved angle drop (0.3 in. or greater)
- FX: flexible copper shaft
- /200K-1M, /1-3M: frequency (MP)
- /200K-1M, /1-6M: frequency (MTF)

Note: probes pictured on this page have the curved option

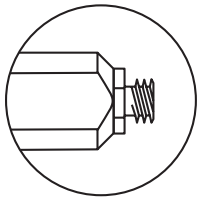

Microdot connector

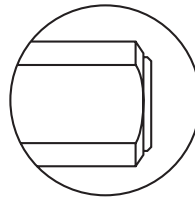

Fischer triax connector

Probe Length		30° Tip 0.5 in. Drop					
		Microdot Connector		Fischer Triax Connector		Microdot	Fischer Triax
		1/8 in. Shielded	1/16 in. Shielded	1/8 in. Shielded	1/16 in. Shielded	1/8 in. Unshielded	1/8 in. Unshielded
3.0 in.	-30	MP305-30	MMP305-30	MTF305-30	MMTF305-30	UMP305-30	UMTF305-30
4.0 in.	-40	MP305-40	MMP305-40	MTF305-40	MMTF305-40	UMP305-40	UMTF305-40
4.5 in.	-45	MP305-45	MMP305-45	MTF305-45	MMTF305-45	UMP305-45	UMTF305-45
5.0 in.	-50	MP305-50	MMP305-50	MTF305-50	MMTF305-50	UMP305-50	UMTF305-50
6.0 in.	-60	MP305-60	MMP305-60	MTF305-60	MMTF305-60	UMP305-60	UMTF305-60
6.5 in.	-65	MP305-65	MMP305-65	MTF305-65	MMTF305-65	UMP305-65	UMTF305-65
7.0 in.	-70	MP305-70	MMP305-70	MTF305-70	MMTF305-70	UMP305-70	UMTF305-70
8.0 in.	-80	MP305-80	MMP305-80	MTF305-80	MMTF305-80	UMP305-80	UMTF305-80
9.0 in.	-90	MP305-90	MMP305-90	MTF305-90	MMTF305-90	UMP305-90	UMTF305-90
10.0 in.	-100	MP305-100	MMP305-100	MTF305-100	MMTF305-100	UMP305-100	UMTF305-100
11.0 in.	-110	MP305-110	MMP305-110	MTF305-110	MMTF305-110	UMP305-110	UMTF305-110
12.0 in.	-120	MP305-120	MMP305-120	MTF305-120	MMTF305-120	UMP305-120	UMTF305-120

Defectometer Probes

Hole Probes

Standard Configuration

- 2 in. working length
- 4 in. overall length
- Black plastic handle

Next Page

Microdot connector

- Black plastic tip
- Brass shaft
- Black plastic handle

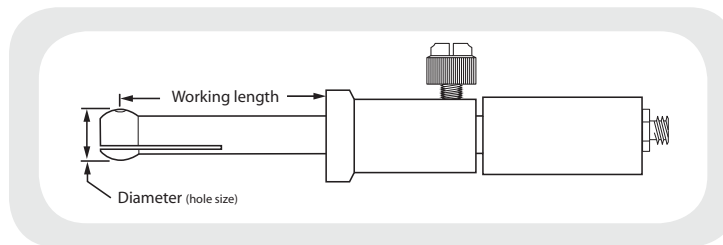

Options

Add to end of part number if other than standard /x.xWL: working length

Decimal	Fractional	Metric	Hole Probes		
			Nonferrous	Nonferrous	Ferrous
			Unshielded	Shielded	Unshielded
0.125 in.	1/8 in.	3.17 mm	BDN-8	BDSN-8	BDF-8
0.156 in.	5/32 in.	3.96 mm	BDN-10	BDSN-10	BDF-10
		4 mm	BDN-4.0M	BDSN-4.0M	BDF-4.0M
0.187 in.	3/16 in.	4.75 mm	BDN-12	BDSN-12	BDF-12
		5 mm	BDN-5.0M	BDSN-5.0M	BDF-5.0M
		6 mm	BDN-6.0M	BDSN-6.0M	BDF-6.0M
0.250 in.	1/4 in.	6.34 mm	BDN-16	BDSN-16	BDF-16
		7 mm	BDN-7.0M	BDSN-7.0M	BDF-7.0M
0.312 in.	5/16 in.	7.92 mm	BDN-20	BDSN-20	BDF-20
		9 mm	BDN-9.0M	BDSN-9.0M	BDF-9.0M
0.375 in.	3/8 in.	9.52 mm	BDN-24	BDSN-24	BDF-24
		11 mm	BDN-11.0M	BDSN-11.0M	BDF-11.0M
0.437 in.	7/16 in.	11.09 mm	BDN-28	BDSN-28	BDF-28
0.500 in.	1/2 in.	12.69 mm	BDN-32	BDSN-32	BDF-32
		13 mm	BDN-13.0M	BDSN-13.0M	BDF-13.0M
0.562 in.	9/16 in.	14.26 mm	BDN-36	BDSN-36	BDF-36
		15 mm	BDN-15.0M	BDSN-15.0M	BDF-15.0M
0.625 in.	5/8 in.	15.86 mm	BDN-40	BDSN-40	BDF-40
0.687 in.	11/16 in.	17.44 mm	BDN-44	BDSN-44	BDF-44
0.750 in.	3/4 in.	19.03 mm	BDN-48	BDSN-48	BDF-48



Surface Probes

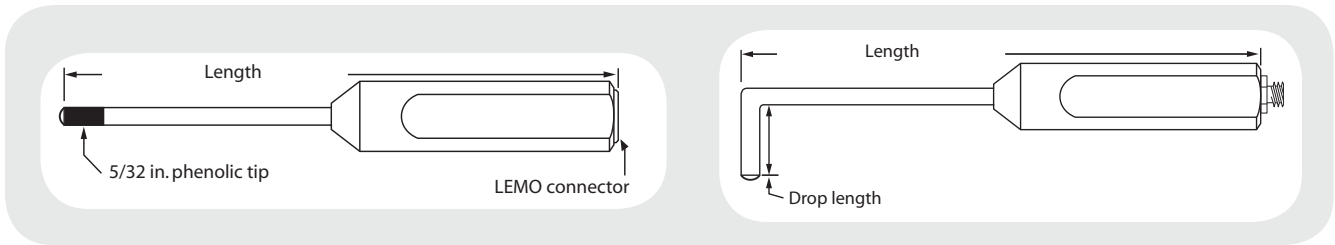

Options

Add to end of part number if other than standard /LOO: LEMO connector

Probe Length		Surface Probes					
		Nonferrous/Unshielded		Nonferrous/Shielded		Ferrous/Unshielded	
		Straight	90°/0.5 in. Drop	Straight	90°/0.5 in. Drop	Straight	90°/0.2 in. Drop
2.0 in.	-20	DN-20	--	DSN-20	--	DF-20	--
3.0 in.	-30	DN-30	DN905-30	DSN-30	DSN905-30	DF-30	DF902-30
4.0 in.	-40	DN-40	DN905-40	DSN-40	DSN905-40	DF-40	DF902-40
5.0 in.	-50	DN-50	DN905-50	DSN-50	DSN905-50	DF-50	DF902-50
6.0 in.	-60	DN-60	DN905-60	DSN-60	DSN905-60	DF-60	DF902-60
6.5 in.	-65	DN-65	DN905-65	DSN-65	DSN905-65	DF-65	DF902-65
7.0 in.	-70	DN-70	DN905-70	DSN-70	DSN905-70	DF-70	DF902-70
8.0 in.	-80	DN-80	DN905-80	DSN-80	DSN905-80	DF-80	DF902-80
9.0 in.	-90	DN-90	DN905-90	DSN-90	DSN905-90	DF-90	DF902-90
10.0 in.	-100	DN-100	DN905-100	DSN-100	DSN905-100	DF-100	DF902-100
11.0 in.	-110	DN-110	DN905-110	DSN-110	DSN905-110	DF-110	DF902-110
12.0 in.	-120	DN-120	DN905-120	DSN-120	DSN905-120	DF-120	DF902-120

Low-Frequency Probes

Spot Bridge

Standard Configuration

- 2-pin Microdot
- Black case
- Polished steel

Next Page

- 2-pin Microdot
- Black case
- Polished steel

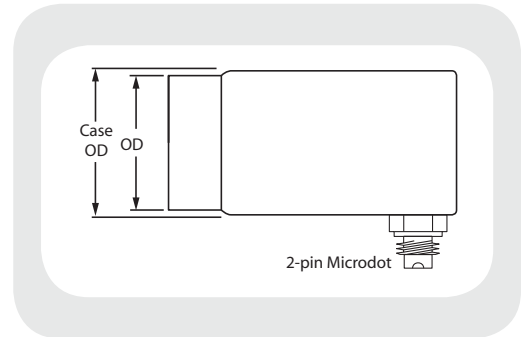

Frequency Range	Spot Bridge		
	OD	Case OD	Part number
50–500 Hz	0.275 in.	0.350 in.	LS013-5
50–500 Hz	0.440 in.	0.575 in.	LS015-5
50–500 Hz	0.850 in.	0.920 in.	LS018-1
50–500 Hz	0.950 in.	1.040 in.	LS019-1
50–500 Hz	1.000 in.	1.090 in.	LS0110-1
50–500 Hz	1.250 in.	1.330 in.	LS0112-1
100 Hz–2 kHz	0.375 in.	0.425 in.	LS023-2
100 Hz–2 kHz	0.670 in.	0.740 in.	LS026-1
100 Hz–2 kHz	1.000 in.	1.100 in.	LS0210-1
200 Hz–4 kHz	0.250 in.	0.320 in.	LS042-1
300 Hz–5 kHz	0.312 in.	0.375 in.	LS053-5
300 Hz–5 kHz	0.475 in.	0.550 in.	LS055-2
300 Hz–5 kHz	0.600 in.	0.675 in.	LS056-1
500 Hz–5 kHz	0.280 in.	0.350 in.	LS102-1
500 Hz–5 kHz	0.395 in.	0.470 in.	LS104-1
500 Hz–5 kHz	0.500 in.	0.580 in.	LS105-1
1 kHz–8 kHz	0.275 in.	0.375 in.	LS203-5
1 kHz–8 kHz	0.400 in.	0.460 in.	LS204-1
1 kHz–8 kHz	0.500 in.	0.570 in.	LS205-1
3 kHz–20 kHz	0.375 in.	0.440 in.	LS503-2
3 kHz–20 kHz	0.425 in.	0.490 in.	LS504-1
3 kHz–20 kHz	0.500 in.	0.570 in.	LS508-1
5 kHz–30 kHz	0.300 in.	0.350 in.	LS1002-1
5 kHz–30 kHz	0.490 in.	0.580 in.	LS1005-1
5 kHz–30 kHz	0.900 in.	0.960 in.	LS1008-1
10 kHz–50 kHz	0.300 in.	0.350 in.	LS2003-1
10 kHz–50 kHz	0.490 in.	0.550 in.	LS2005-1
10 kHz–50 kHz	0.500 in.	0.560 in.	LS1504-1

Options

Add to end of part number if other than standard	/TF: Fischer triax connector
	/4F: Four pin Fischer connector
	/4L: Four pin LEMO connector



Ring Bridge

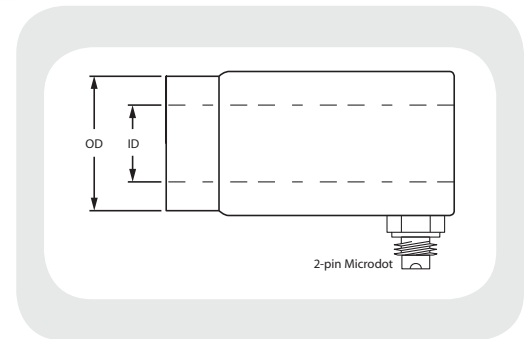

Frequency Range	Ring Bridge		
	ID	OD	Part number
50–500 Hz	0.350 in.	0.750 in.	LR017-5
50–500 Hz	0.400 in.	0.900 in.	LR01-731
50–500 Hz	0.425 in.	0.900 in.	LR019-1
50–500 Hz	0.500 in.	1.000 in.	LR0110-1
50–500 Hz	0.625 in.	0.995 in.	LR01-743
50–500 Hz	0.650 in.	1.065 in.	LR0111-1
50–500 Hz	0.700 in.	1.300 in.	LR0113-5
50–500 Hz	0.750 in.	1.280 in.	LR0114-2
50–500 Hz	0.800 in.	1.250 in.	LR0112-3
50–500 Hz	0.800 in.	1.400 in.	LR0114-5
50–500 Hz	1.000 in.	1.510 in.	LR0115-1
100 Hz–2 kHz	0.400 in.	0.880 in.	LR028-1
100 Hz–2 kHz	0.500 in.	1.050 in.	LR0212-1
300 Hz–5 kHz	0.200 in.	0.605 in.	LR056-1
300 Hz–5 kHz	0.300 in.	0.780 in.	LR058-1
300 Hz–5 kHz	0.323 in.	0.680 in.	LR058-2
300 Hz–5 kHz	0.400 in.	0.750 in.	LR057-5
300 Hz–5 kHz	0.500 in.	1.000 in.	LR0510-5
500 Hz–10 kHz	0.255 in.	0.650 in.	LR106-1
500 Hz–10 kHz	0.300 in.	0.750 in.	LR107-1
500 Hz–10 kHz	0.315 in.	0.680 in.	LR106-2
1 kHz–15 kHz	0.158 in.	0.375 in.	LR204-1
1 kHz–15 kHz	0.300 in.	0.790 in.	LR208-1
1 kHz–15 kHz	0.350 in.	0.700 in.	LR207-5
1 kHz–15 kHz	0.400 in.	0.840 in.	LR209-1
3 kHz–20 kHz	0.255 in.	0.650 in.	LR506-1
3 kHz–20 kHz	0.315 in.	0.680 in.	LR506-2

Options

Add to end of part number if other than standard	/TF: Fischer triax connector
	/4F: Four pin Fischer connector
	/4L: Four pin LEMO connector

Spot Reflection

Standard Configuration

- 2-pin Microdot
- Black case
- Polished steel

Next Page

- 2-pin Microdot
- Black case
- Polished steel

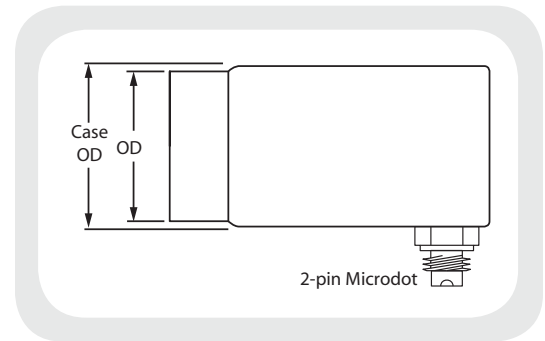

Frequency Range	Spot Reflection		
	OD	Case OD	Part number
50 Hz–3 kHz	0.312 in.	0.375 in.	RS013-5
50 Hz–3 kHz	0.600 in.	0.670 in.	RS016-5
50 Hz–3 kHz	0.700 in.	0.780 in.	RS017-5
50 Hz–3 kHz	0.800 in.	0.880 in.	RS018-1
50 Hz–3 kHz	0.925 in.	1.000 in.	RS019-4
50 Hz–3 kHz	1.000 in.	1.080 in.	RS0110-1
50 Hz–3 kHz	1.060 in.	1.120 in.	RS0110-2
50 Hz–3 kHz	1.750 in.	1.850 in.	RS0118-1
100 Hz–5 kHz	0.440 in.	0.520 in.	RS023-1
100 Hz–5 kHz	0.800 in.	0.880 in.	RS028-2
100 Hz–5 kHz	0.680 in.	0.750 in.	RS036-1
200 Hz–10 kHz	0.310 in.	0.360 in.	RS053-1
200 Hz–10 kHz	0.312 in.	0.375 in.	RS053-5
200 Hz–10 kHz	0.390 in.	0.450 in.	RS054-1
200 Hz–10 kHz	0.500 in.	0.575 in.	RS055-1
200 Hz–10 kHz	0.610 in.	0.700 in.	RS057-5
500 Hz–15 kHz	0.312 in.	0.375 in.	RS203-5
500 Hz–15 kHz	0.425 in.	0.495 in.	RS204-2
500 Hz–15 kHz	0.460 in.	0.500 in.	RS204-1
500 Hz–15 kHz	0.500 in.	0.560 in.	RS205-5
1 kHz–20 kHz	0.300 in.	0.360 in.	RS093-1
1 kHz–20 kHz	0.350 in.	0.420 in.	RS093-2
2 kHz–50 kHz	0.325 in.	0.420 in.	RS503-1
2 kHz–50 kHz	0.450 in.	0.525 in.	RS504-1
2 kHz–50 kHz	0.800 in.	0.865 in.	RS508-1
4 kHz–80 kHz	0.325 in.	0.420 in.	RS803-1
5 kHz–100 kHz	0.575 in.	0.660 in.	RS1005-2
5 kHz–100 kHz	1.050 in.	1.130 in.	RS1010-1

Options

Add to end of part number if other than standard	/TF: Fischer triax connector
	/4F: Four pin Fischer connector
	/4L: Four pin LEMO connector



Ring Reflection



Frequency range	Ring Reflection		
	ID	OD	Part number
50 Hz-3 kHz	0.400 in.	0.800 in.	RR018-5
50 Hz-3 kHz	0.500 in.	1.000 in.	RR0110-5
50 Hz-3 kHz	0.600 in.	1.160 in.	RR0112-5
50 Hz-3 kHz	0.700 in.	1.300 in.	RR0113-5
50 Hz-3 kHz	0.800 in.	1.400 in.	RR0114-5
50 Hz-3 kHz	0.900 in.	1.500 in.	RR0115-5
50 Hz-3 kHz	1.000 in.	1.600 in.	RR0116-5
80 Hz-4 kHz	0.350 in.	0.750 in.	RR017-1
80 Hz-4 kHz	0.500 in.	1.000 in.	RR019-2
80 Hz-4 kHz	0.680 in.	1.000 in.	RR0110-3
80 Hz-4 kHz	0.800 in.	1.500 in.	RR0115-1
80 Hz-4 kHz	0.860 in.	1.250 in.	RR0115-4
80 Hz-4 kHz	1.100 in.	1.740 in.	RR0119-1
80 Hz-4 kHz	1.330 in.	1.870 in.	RR0120-1
100 Hz-5 kHz	0.250 in.	0.600 in.	RR026-1
100 Hz-5 kHz	0.312 in.	0.790 in.	RR028-1
100 Hz-5 kHz	0.430 in.	0.750 in.	RR027-2
100 Hz-5 kHz	0.546 in.	1.050 in.	RR0210-1
100 Hz-5 kHz	0.560 in.	1.090 in.	RR0211-1
200 Hz-10 kHz	0.200 in.	0.605 in.	RR056-1
200 Hz-10 kHz	0.300 in.	0.815 in.	RR058-1
300 Hz-10 kHz	0.425 in.	0.750 in.	RR057-2
500 Hz-20 kHz	0.250 in.	0.650 in.	RR206-5
500 Hz-20 kHz	0.350 in.	0.700 in.	RR207-5
500 Hz-20 kHz	0.335 in.	0.600 in.	RR207-1
5 kHz-80 kHz	0.300 in.	0.600 in.	RR1006-5
5 kHz-80 kHz	0.450 in.	0.900 in.	RR1009-5
10 kHz-100 kHz	0.345 in.	0.550 in.	RR2007-1

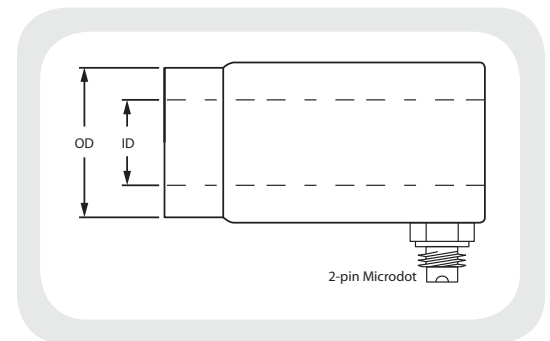

Options

Add to end of part number if other than standard	/TF: Fischer triax connector
	/4F: Four pin Fischer connector
	/4L: Four pin LEMO connector

Miscellaneous Probes

Sliding Probes

Standard Configuration

Type A

- 2-pin Microdot
- Black phenolic case
- Tridirectional scan
- 1 in. diameter

Type B

- 2 ea. 1-pin Microdot
- Black Delrin® case
- Single-direction scan
- Acrylic spacer

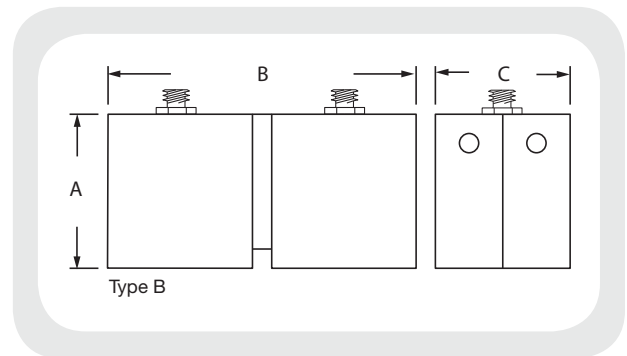
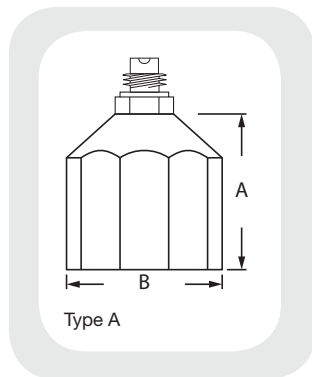

Options

Add to end of part number if other than standard

/TF: Fischer triax connector

/4F: Four pin Fischer connector

Type	Part Number	Frequency	Sliding Probes			
			Dimensions			Connector
			A	B	C	
A	LTW405-1	100 Hz–4 kHz	1.15 in.	1.25 in.		2-pin Microdot
A	LTW1007-1	1–15 kHz	1.10 in.	2.00 in.		2-pin Microdot
A	LTW1004-2	2–20 kHz	1.10 in.	1.00 in.		2-pin Microdot
A	LTW1004-3	5–30 kHz	1.10 in.	1.00 in.		2-pin Microdot
B	LTW0419-1	100 Hz–5 kHz	1.0 in.	3.35 in.	0.75 in.	(2) 1-pin Microdot
B	LTW2018	500 Hz–10 kHz	1.0 in.	1.76 in.	1.0 in.	(2) 1-pin Microdot
B	LTW0423-1	500 Hz–10 kHz	1.0 in.	1.75 in.	1.0 in.	(2) 1-pin Microdot
B	LTW5010-1	1–20 kHz	1.0 in.	1.0 in.	1.0 in.	(2) 1-pin Microdot
B	LTW0210-1	2–40 kHz	1.0 in.	1.0 in.	1.0 in.	(2) 1-pin Microdot
B	LTW0210-2	3–50 kHz	1.0 in.	1.0 in.	1.0 in.	(2) 1-pin Microdot
B	LTW1022	5–100 kHz	1.0 in.	1.5 in.	0.75 in.	(2) 1-pin Microdot



Wheel Probes

Wheel Standards

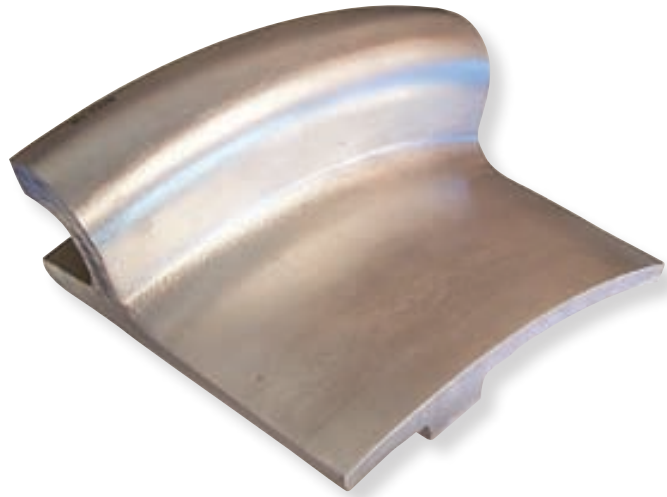

NDT Engineering Corp. can supply wheel probes and reference standards for the most popular aircraft in service. Please have aircraft make, model, and wheel manufacture when you talk to our sales staff for availability. If we do not carry what you are looking for, all we need is a sample of the wheel in question; either a section cut from the wheel or a full wheel. Customer is responsible for return shipping costs if they want the wheel returned in same condition as received

Aircraft	Wheel Probes		Wheel Standards	
	Main	Nose (Tail)	Main	Nose (Tail)
717	WP-717M	WP-717N	WS-717M	WS-717N
727	WP-727M	WP-727N	WS-727M	WS-727N
737/100-200	WP-737M/100-200	WP-737N/100-200	WS-737M/100-200	WS-737N/100-200
747	WP-747M	WP-747N	WS-747M	WS-747N
757	WP-757M	WP-757N	WS-757M	WS-757N
767	WP-767M	WP-767N	WS-767M	WS-767N
A320	WP-A320M	WP-A320N	WS-A320M	WS-A320N
DC-9/30	WP-DC9M/30	WP-DC9N/30	WS-DC9M/30	WS-DC9N
DC-10	WP-DC10M	WP-DC10N	WS-DC10M	WS-DC10N
MD-80 Series	WP-MD80M	WP-MD80N	WS-MD80M	WS-MD80N
Dash 8	WP-DH8M-32D	WP-DH8N	WS-DH8M-32D	WS-DH8N
KC-135	WP-KC135M	WP-KC135N	WS-KC135M	WS-KC135N
C-130	WP-C130M	WP-C130N	WS-C130M	WS-C130N
B-52	WP-B52M	WP-B52N	WS-B52M	WS-B52N
F-15C Eagle, F-15D Eagle	WP-F15CDM	WP-F15CDM	WS-F15CDM	WS-F15CDM
F-15E Strike Eagle	WP-F15EM	WP-F15EN	WS-F15EM	WS-F15WN
F-16	WP-F16M	WP-F16N	WS-F16M	WS-F16N
A-10	WP-A10M	WP-A10N	WS-A10M	WS-A10N
UH-60	WP-UH60M	WP-UH60T	WS-UH60M	WS-UH60N

Blade

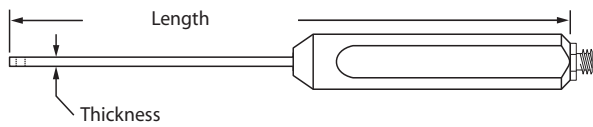

Straight type - Top view

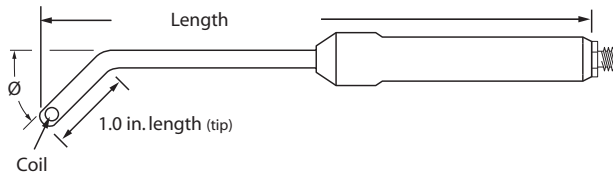

Angle type - Side view

Finger

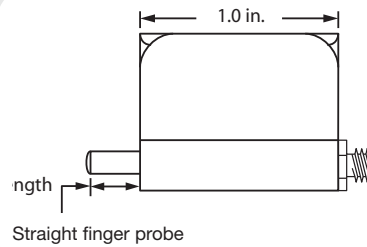

Straight finger probe

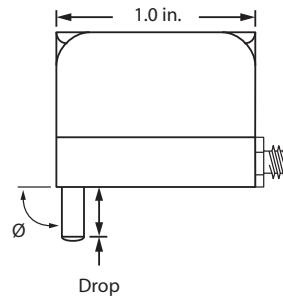

Angle finger probe

<i>Blade</i>		
Part number	Angle Ø	Thickness
MP.045-60BL	Straight	0.045 in.
MP.060-60BL	Straight	0.060 in.
MP.090-60BL	Straight	0.090 in.
MP90.045-60BL	90°	0.045 in.
MP90.060-60BL	90°	0.060 in.
MP90.090-60BL	90°	0.090 in.
MP45.045-60BL	45°	0.045 in.
MP45.060-60BL	45°	0.060 in.
MP45.090-60BL	45°	0.090 in.
MP30.045-60BL	30°	0.045 in.
MP30.060-60BL	30°	0.060 in.
MP30.090-60BL	30°	0.090 in.

<i>Finger</i>			
Part Number	Angle Ø	Drop	Tip Length
TPF-902	90°	0.2 in.	--
TPF-904	90°	0.4 in.	--
TPF-906	90°	0.6 in.	--
TPF-603	60°	0.3 in.	--
TPF-605	60°	0.5 in.	--
TPF-453	45°	0.3 in.	--
TPF-455	45°	0.5 in.	--
TPF-02	Straight	--	0.2 in.
TPF-03	Straight	--	0.3 in.
TPF-04	Straight	--	0.4 in.
TPF-06	Straight	--	0.6 in.
TPF-10	Straight	--	1.0 in.



Spring Loaded



Flexshaft

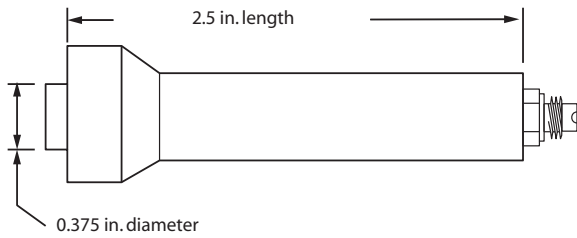

The part numbers listed below are configured with 2-pin Microdot connectors. To configure for Fischer® triax connector, refer to the chart below.

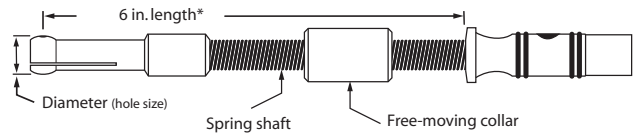

* Part numbers listed have a length of 6 in. Other lengths are configured by adding the desired length, in inches or millimeters, to the end of the part number.

Example: BPU-16/FX8
 • ¼ in. diameter
 • 8 in. working length

Options

Add to end of part number if other than standard /TF: Fischer triax connector

Spring Loaded	
Part Number	Range
SNG375-2.5L/500K	300 kHz–1 MHz
SNG375-2.5L/200K	50–300 kHz
SNG375-2.5L/50K	30–100 kHz
SNG375-2.5L/20K	10–50 kHz
SNG375-2.5L/10K	5–30 kHz
SNG375-2.5L/5K	2–15 kHz
SNG375-2.5L/2K	1–10 kHz
SNG375-2.5L/1K	1–5 kHz
SNG375-2.5L/500 Hz	100 Hz–2 kHz

Flexshaft	
Instrument Driver	Part Number
Universal Rotor	BPU-10/FX16
Foerster Rotor	BDP-10/FX6
Elotest Standard Rotor	BPE-10/FX6
Elotest Mini Rotor	BPEM-10/FX6
Rechii Rotor	BPRA-10/FX6
PS5 Rotor	PS5-10/FX6
Zetec Rotor	BPZ-10/FX6

Sizes listed are based on standard measurement of 1/64 in. increments. For example: -10=¹⁰/₆₄, or ⁵/₃₂. For millimeters, substitute with metric sizes. Example: BPRA-11M/FX203M

Cables and Adapters

Reference Coil Adapters and Cables Rotary Adaptors



Reference coil adapters are used with manually operated, single-coil probes such as the MP-type surface probes or the BPM-type manual bolt hole probes and must be used with a CBM-type cable.
Ask for cable CBM-6 when placing an order.

Instrument Driver	Probe Connection						
	Universal	Foerster	Rechii	PS5	Elotest Standard	Elotest Mini	Zetec
Universal Rotor*	--	RAU-D	RAU-RA	RAU-PS5	RAU-E	RAU-EM	RU-Z
Foerster Rotor	RAD-U	--	RAD-RA	RAD-PS5	RAD-E	RAD-EM	RD-Z
Rechii Rotor	RARA-U	RARA-D	--	RARA-PS5	RARA-E	RARA-EM	RRA-Z
PS5 Rotor	RAP5-U	RAP5-D	RAP5-RA	--	RAP5-E	RAP5-EM	RP5-Z
Elotest Standard Rotor	RAE-U	RAE-D	RAE-RA	RAE-PS5	--	RAE-EM	RE-Z
Elotest Mini Rotor	RAEM-U	RAEM-D	RAEM-RA	RAEM-PS5	RAEM-E	--	REM-Z
Zetec Rotor	RAZ-U	RAZ-D	RAZ-RA	RAZ-PS5	RAZ-E	RAEM-Z	--
Physical Acoustics Rotor	RAA-U	RAA-D	RAA-PS5	RAA-E	RAA-EM	RAA-Z	--

* For Hocking Phasec 1.1 Rotor and Elotest Mini-Rotor

Instrument	Probe Connector		Reference Coil Adaptors (BNC)
	Microdot	Fischer Coax	
Zetec MIZ-10, MIZ-20, MIZ-22	CZ-M-6/50-500K	CZ-CF-6/50-500K	AZ-BN/50-500K
Zetec MIZ-21	CZ21-M-6/50-500K	CZ21-CF-6/50-500K	AZ21-BN/50-500K
Nortec NDT-18, NDT-19, NDT-23, NDT-24	CBR-M-6/50-500K	CBR-CF-6/50-500K	ABR-BN/50-500K
Nortec 1000, 2000	CN16-M-6/50-500K	CN16-CF-6/50-500K	AN16-BN/50-500K
Hocking Phasec 1.1, AV-10, AV100	CH-M-6/50-500K	CH-CF-6/50-500K	AH-BN/50-500K
Hocking Phasec 2, 2200	CH22-M-6/50-500K	CH22-CF-6/50-500K	AH22-BN/50-500K
Foerster Defectoscope SD 2.832, AF 2.833	CD-M-6/50-500K	CD-CF-6/50-500K	AD-BN/50-500K
Elotest B1, B2	ACB1-M-6/50-500K	ACB1-CF-6/50-500K	AB1-BN/50-500K

* Other lengths are available.



Bridge Cables and Adapters



Instrument	Probe connector			
	2-Pin Microdot	Fischer Triax	4-pin Fischer	Dual Microdot
Zetec MIZ-10, MIZ-20, and MIZ-22	CZ-2M-6	CZ-TF-6	CZ-4F-6	CZ-MSE-6
Zetec MIZ-21	CZ21-2M-6	CZ21-TF-6	CZ21-4F-6	CZ21-MSE-6
Nortec NDT-18, NDT-19, NDT-23, and NDT-24*	CBR-2M-6	CBR-TF-6	CBR-4F-6	CBR-MSE-6
Nortec 1000 and 2000	CN16-2M-6	CN16-TF-6	CN16-4F-6	CN16-MSE-6
Hocking Phasec 1.1, AV-10, and AV100	CH-2M-6	CH-TF-6	CH-4F-6	CH-MSE-6
Hocking Phasec 2, 2200	CH22-2M-6	CH22-TF-6	CH22-4F-6	CH22-MSE-6
Foerster Defectoscope SD 2.832, AF 2.833	CFSD-2M-6	CFSD-TF-6	CFSD-4F-6	CFSD-MSE-6
Elotest B1 and B2	ACB1-2M-6	ACB1-TF-6	ACB1-4F-6	ACB1-MSE-6
R/D Tech OmniScan MX EC	COS-2M-6	COS-TF-6	COS-4F-6	COS-MFE-6

* Can be used on Nortec 1000 and 2000 with 8-pin adaptor.

Instrument	Cable Connector					
	MIZ-10*	MIZ-21*	NDT-18*	NDT-1000*	Phasec 1.1*	Phasec 2200*
Zetec MIZ-10, MIZ-20, and MIZ-22	--	AZ-Z21	AZ-BR	AZ-N16	AZ-H	AZ-H22
Zetec MIZ-21	AZ21-Z	--	AZ21-BR	AZ21-N16	AZ21-H	AZ21-H22
Nortec NDT-18, 19, 23, and 24	ABR-Z	ABR-Z21	--	ABR-N16	ABR-H	ABR-H22
Nortec NDT-1000, 2000	AN16-Z	AN16-Z21	AN16-BR	--	AN16-H	AN16-H22
Hocking Phasec 1.1, AV-10, and AV-100	AH-Z	AH-Z21	AH-BR	AH-N16	--	AH-H22
Hocking Phasec 2, 2200	AH22-Z	AH22-Z21	AH22BR	AH22-N16	AH22-H	--
Foerster Defectoscope SD 2.832, AF 2.833	AFSD-Z	AFSD-Z21	AFSD-BR	AFSD-N16	AFSD-H	AFSD-H22
Elotest B1 and B2	AB1-Z	AB1-Z21	AB1-BR	AB1-N16	AB1-H	AB1-H22
R/D Tech OmniScan MX EC	AOS-Z	AOS-Z21	AOS-BR	AOS-N16	AOS-H	AOS-H22

* Includes probe connections for those under instrument list.

Reflection Cables and Adapters



Instrument	Probe Connector			
	2-Pin Microdot	Fischer Triax	4-Pin Fischer	Dual Microdot
Zetec MIZ-10, MIZ-20, and MIZ-22	CZ-2M-6	CZ-TF-6	CZ-4F-6	CZ-MSE-6
Zetec MIZ-21	CZ21-2M-6	CZ21-TF-6	CZ21-4F-6	CZ21-MSE-6
Nortec NDT-18, 19, 23, and 24*	CRBR-2M-6	CRBR-TF-6	CRBR-4F-6	CRBR-MSE-6
Nortec 1000 and 2000	CRN16-2M-6	CRN16-TF-6	CRN16-4F-6	CRN16-MSE-6
Hocking Phasec 1.1, AV-10, AV100	CRH-2M-6	CRH-TF-6	CRH-4F-6	CRH-MSE-6
Hocking Phasec 2, 2200	CRH22-2M-6	CRH22-TF-6	CRH22-4F-6	CRH22-MSE-6
Foerster Defectoscope	CRFSD-2M-6	CRFSD-TF-6	CRFSD-4F-6	CRFSD-MSE-6
Elotest B1 and B2	CB1-2M-6	CB1-TF-6	CB1-4F-6	CB1-MSE-6
R/D Tech OmniScan MX EC	CROS-2M-6	CROS-TF-6	CROS-4F-6	CROS-MSE-6

* Can be used on Nortec 1000 and 2000 with 8-pin adaptor.

Instrument	Cable Connector					
	MIZ-10*	MIZ-21*	NDT-18*	NDT-1000*	Phasec 1.1*	Phasec 2200*
Zetec MIZ-10, MIZ-20, and MIZ-22	--	AZ-Z21	ARZ-BR	ARZ-N16	ARZ-H	ARZ-H22
Zetec MIZ-21	AZ21-Z	--	ARZ21-BR	ARZ21-N16	ARZ21-H	ARZ21-H22
Nortec NDT-18, 19, 23, and 24	ARBR-Z	ARBR-Z21	--	ARBR-N16	ARBR-H	ARBR-H22
Nortec NDT-1000, 2000	ARN16-Z	ARN16-Z21	ARN16-BR	--	ARN16-H	ARN16-H22
Hocking Phasec 1.1, AV-10, and AV-100	ARH-Z	ARH-Z21	ARH-BR	ARH-N16	--	ARH-H22
Hocking Phasec 2, 2200	ARH22-Z	ARH22-Z21	ARH22BR	ARH22-N16	ARH22-H	--
Foerster Defectoscope	ARFSD-Z	ARFSD-Z21	ARFSD-BR	ARFSD-N16	ARFSD-H	ARFSD-H22
Elotest B1 and B2	ARB1-Z	ARB1-Z21	ARB1-BR	ARB1-N16	ARB1-H	ARB1-H22
R/D Tech OmniScan MX EC	AROS-Z	AROS-Z21	AROS-BR	AROS-N16	AROS-H	AROS-H22

* Includes probe connections for those under instrument list

Probe Kits



Hole Probes Surface Probes Low-Frequency Probes



<i>Hole Probes</i>		<i>Surface Probes</i>		<i>Low-frequency Probes</i>	
Part Number	Contents	Part Number	Contents	Part Number	Contents
BPMK-1064-32	28 BPM probes 5/32 in. through 1.0 in. in 1/32 in. increments	MPK-5	MP-30, MP902-40B MP905-50B, MP455-50C TPF-902, CBM-6	LFK-5	LS803-1, LS203-1, LR058-1, LR019-1, LR0112-1 Cables as required
BPMFK-1064-32	28 BPMF probes 5/32 in. through 1.0 in. in 1/32 in. increments	MPK-7	MPK-5 plus: MP-50, MP905-50	LFK-7	LFK-7 plus: LTW0419-1, RR058-1
BPUK-1048-32	20 BPU probes 5/32 in. through 3/4 in. in 1/32 in. increments	MPK-9	MPK-7 plus: MP-60FX, MP9003-50B, CBM-6	LFK-10	LFK-7 plus: LS2003-1, LR0115-1 LTW1004-1, LTW1007-1 Cables as required
BXUK-1048	10 BXU probes covering hole sizes from 5/32 in. to 3/4 in.	MPK-14	MPK-9 plus: TPF-30, MP902-50C, MP305-50C MP902-60FX, MP9003- 60, CBM-6		

Ultrasound Products

Ordering Information

Quality of workmanship takes priority at NDT Engineering Corporation. Components and materials used in the manufacture of our transducers are checked to ensure that they comply with NDT Engineering Corporation specifications. Attention is paid to every aspect of design, production, and assembly of all NDT Engineering Corporation transducers.

The transducer is one of the most critical components of any ultrasonic system. A great deal of attention should be paid to selecting the proper transducer for the application. Consideration should be given to the use of focused transducers, transducers with wear surfaces that are appropriate for the test material, and the choice of the appropriate frequency and element diameter.

While these guidelines are quite useful, each application is unique and performance will be dependent on transducer configuration, frequency, and element diameter. The summaries below provide a general impression of the characteristics of each transducer series found in this section of the catalog.

<i>Transducer Series</i>	<i>Description</i>
SUC	Contact transducers
SCD and SCDR	Delay line transducers
SUD and SUDR	Dual element transducers
SX	0.187 in. element shear wave transducers
SUSM	0.187 in. element shear wave transducers
SUM	0.250 in. element shear wave transducers
SU and S	0.375 in. and 0.500 in. element shear wave transducers
SCT and SCW	Quickfit™ shear wave transducers and wedges
SUI and SUSI	Immersion transducers

Except for our line of standard contact transducers (SUC) found on page 37, all transducers follow a specific numbering format that is easy to use in selecting both the proper transducer from this catalog and the design of special requirement transducers.

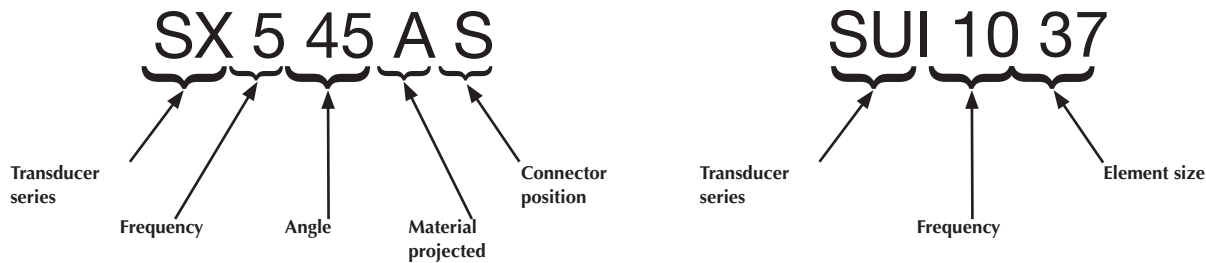

Part Number	SX 545AS (page 40) 0.187 in. shear wave transducer 5 MHz frequency 45° in aluminum Side-mounted Microdot	Part Number	SUI 1037 (page 45) Standard immersion transducer 10 MHz frequency 0.375 in. element
-------------	--	-------------	--



Contact Transducers

Standard



Standard Contact Transducer				
Element		Dimensions		Part Number
Frequency	Diameter	A	B	
1.0 MHz	0.375 in.	0.525 in.	0.500 in.	SUC 157-1
1.0 MHz	0.500 in.	0.650 in.	0.625 in.	SUC 170
1.0 MHz	0.750 in.	0.900 in.	1.00 in.	SUC 156
1.0 MHz	1.000 in.	1.150 in.	1.250 in.	SUC 155
2.25 MHz	0.250 in.	0.400 in.	0.500 in.	SUC 162
2.25 MHz	0.312 in.	0.465 in.	0.500 in.	SUC 161-1
2.25 MHz	0.375 in.	0.525 in.	0.500 in.	SUC 161
2.25 MHz	0.500 in.	0.650 in.	0.625 in.	SUC 160
2.25 MHz	0.750 in.	0.900 in.	1.000 in.	SUC 159
2.25 MHz	1.000 in.	1.125 in.	1.250 in.	SUC 158
2.25 MHz	1.125 in.	1.275 in.	1.250 in.	SUC 238
5.0 MHz	0.187 in.	0.250 in.	0.300 in.	SUC 166-1B
5.0 MHz	0.187 in.	0.250 in.	0.500 in.	SUC 166-1A*
5.0 MHz	0.187 in.	0.312 in.	0.500 in.	SUC 166-1*
5.0 MHz	0.250 in.	0.375 in.	0.400 in.	SUC 169*
5.0 MHz	0.250 in.	0.375 in.	0.500 in.	SUC 166*
5.0 MHz	0.250 in.	0.375 in.	0.750 in.	SUC 706*
5.0 MHz	0.250 in.	0.375 in.	1.250 in.	SUC 166-3*
5.0 MHz	0.312 in.	0.465 in.	0.500 in.	SUC 166-2
5.0 MHz	0.312 in.	0.525 in.	0.500 in.	SUC 165
5.0 MHz	0.375 in.	0.625 in.	0.625 in.	SUC 164
5.0 MHz	0.500 in.	0.625 in.	0.625 in.	SUC 477
5.0 MHz	0.750 in.	0.900 in.	1.000 in.	SUC 163
10.0 MHz	0.187 in.	0.250 in.	0.400 in.	SUC 168-1A*
10.0 MHz	0.187 in.	0.312 in.	0.500 in.	SUC 168-1*
10.0 MHz	0.250 in.	0.312 in.	0.400 in.	SUC 168B*
10.0 MHz	0.250 in.	0.350 in.	0.400 in.	SUC 168A*
10.0 MHz	0.250 in.	0.375 in.	0.500 in.	SUC 168*
10.0 MHz	0.250 in.	0.375 in.	0.750 in.	SUC 726*
10.0 MHz	0.312 in.	0.465 in.	0.500 in.	SUC 168-2
10.0 MHz	0.375 in.	0.525 in.	0.500 in.	SUC 167
10.0 MHz	0.500 in.	0.650 in.	1.000 in.	SUC 167-2
10.0 MHz	0.500 in.	0.650 in.	0.625 in.	SUC 167-1
15.0 MHz	0.125 in.	0.188 in.	1.000 in.	SUC 185SR
15.0 MHz	0.125 in.	0.250 in.	0.400 in.	SUC 180**

* Smooth no-knurle grip.
 ** This transducer also has a 6-ft BNC cable attached.

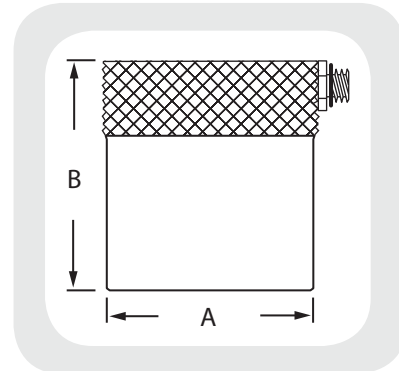

Delay Line

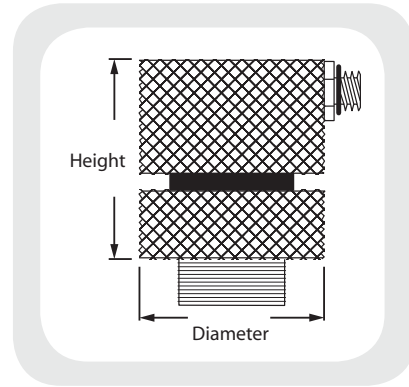
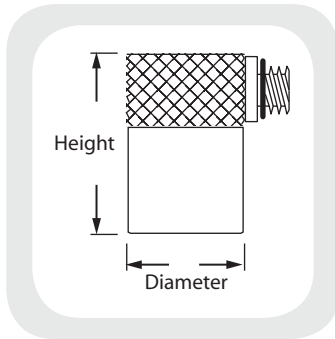
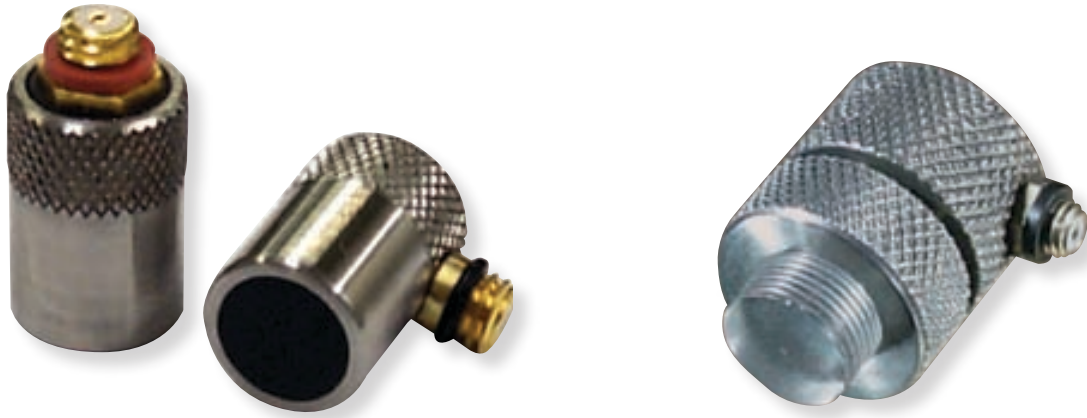

Frequency	Element Size	Permanent Delay Line			Replaceable Delay Line		
		Part Number	Diameter	Height	Part Number	Diameter	Height
1.0 MHz	0.500 in.	SCD 150	0.620 in.	0.650 in.	SCDR 150	0.900 in.	0.965 in.
2.25 MHz	0.250 in.	SCD 225	0.375 in.	0.600 in.	SCDR 225	0.575 in.	0.590 in.
2.25 MHz	0.375 in.	SCD 237	0.520 in.	0.625 in.	SCDR 237	0.750 in.	0.750 in.
2.25 MHz	0.500 in.	SCD 250	0.620 in.	0.650 in.	SCDR 250	0.900 in.	0.965 in.
5.0 MHz	0.250 in.	SCD 525	0.375 in.	0.600 in.	SCDR 525	0.575 in.	0.590 in.
5.0 MHz	0.375 in.	SCD 537	0.520 in.	0.625 in.	SCDR 537	0.750 in.	0.750 in.
5.0 MHz	0.500 in.	SCD 550	0.620 in.	0.650 in.	SCDR 550	0.900 in.	0.965 in.
5.0 MHz	0.750 in.	SCD 575	0.900 in.	0.700 in.	SCDR 575	1.250 in.	0.950 in.
5.0 MHz	1.000 in.	SCD 5100	1.150 in.	1.000 in.	SCDR 5100	1.500 in.	1.200 in.
10.0 MHz	0.125 in.	SCD 1012	0.300 in.	0.600 in.	SCDR 1012	0.390 in.	0.600 in.
10.0 MHz	0.250 in.	SCD 1025	0.375 in.	0.600 in.	SCDR 1025	0.575 in.	0.590 in.
10.0 MHz	0.375 in.	SCD 1037	0.520 in.	0.625 in.	SCDR 1037	0.750 in.	0.750 in.
10.0 MHz	0.500 in.	SCD 1050	0.620 in.	0.650 in.	SCDR 1050	0.900 in.	0.965 in.
15.0 MHz	0.125 in.	SCD 1512	0.300 in.	0.600 in.	SCDR 1512	0.390 in.	0.600 in.
15.0 MHz	0.250 in.	SCD 1525	0.375 in.	0.600 in.	SCDR 1525	0.575 in.	0.590 in.
15.0 MHz	0.375 in.	SCD 1537	0.520 in.	0.625 in.	SCDR 1537	0.750 in.	0.750 in.
15.0 MHz	0.500 in.	SCD 1550	0.620 in.	0.650 in.	SCDR 1550	0.900 in.	0.965 in.
20–25 MHz	0.125 in.	SCD 2012	0.300 in.	0.600 in.	SCDR 2012	0.390 in.	0.600 in.
20–25 MHz	0.250 in.	SCD 2025	0.375 in.	0.600 in.	SCDR 2025	0.575 in.	0.590 in.
20–25 MHz	0.375 in.	SCD 2037	0.520 in.	0.625 in.	SCDR 2037	0.750 in.	0.750 in.



Dual Element - Cylindrical

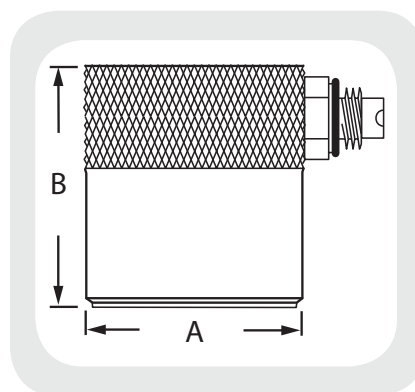

<i>Dual Element Cylindrical Contact Transducers</i>				
Element		Dimensions		Part Number
Frequency	Diameter	A	B	
1.0 MHz	0.250 in.	0.375 in.	0.500 in.	SUD 125
1.0 MHz	0.312 in.	0.437 in.	0.575 in.	SUD 131
1.0 MHz	0.375 in.	0.500 in.	0.625 in.	SUD 137
1.0 MHz	0.500 in.	0.625 in.	0.750 in.	SUD 150
2.25 MHz	0.250 in.	0.375 in.	0.500 in.	SUD 225
2.25 MHz	0.312 in.	0.437 in.	0.575 in.	SUD 231
2.25 MHz	0.375 in.	0.500 in.	0.625 in.	SUD 237
2.25 MHz	0.500 in.	0.625 in.	0.750 in.	SUD 250
5.0 MHz	0.250 in.	0.375 in.	0.500 in.	SUD 525
5.0 MHz	0.312 in.	0.437 in.	0.575 in.	SUD 531
5.0 MHz	0.375 in.	0.500 in.	0.625 in.	SUD 537
5.0 MHz	0.500 in.	0.625 in.	0.750 in.	SUD 550
10.0 MHz	0.250 in.	0.375 in.	0.500 in.	SUD 1025
10.0 MHz	0.312 in.	0.437 in.	0.575 in.	SUD 1031
10.0 MHz	0.375 in.	0.500 in.	0.625 in.	SUD 1037
10.0 MHz	0.500 in.	0.625 in.	0.750 in.	SUD 1050
15.0 MHz	0.250 in.	0.375 in.	0.500 in.	SUD 1525
15.0 MHz	0.312 in.	0.427 in.	0.575 in.	SUD 1531
15.0 MHz	0.375 in.	0.500 in.	0.625 in.	SUD 1537
15.0 MHz	0.500 in.	0.625 in.	0.750 in.	SUD 1550

Shear Wave Transducers

Micro Miniature



Side mount connector

Top mount connector

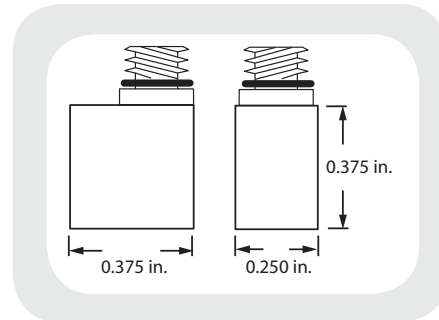
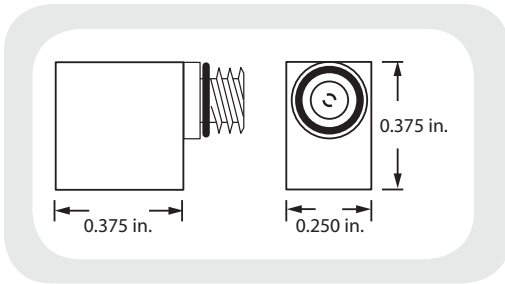

Element		Micro Miniature with Side Mount Connector		Micro Miniature with Top Mount Connector	
		Part Number		Part Number	
Frequency	Angle	Aluminum	Steel	Aluminum	Steel
2.25 MHz	35°	SX 235AS	SX 235SS	SX 235AT	SX 235ST
2.25 MHz	45°	SX 245AS	SX 245SS	SX 245AT	SX 245ST
2.25 MHz	60°	SX 260AS	SX 260SS	SX 260AT	SX 260ST
2.25 MHz	70°	SX 270AS	SX 270SS	SX 270AT	SX 270ST
5.0 MHz	35°	SX 535AS	SX 535SS	SX 535AT	SX 535ST
5.0 MHz	45°	SX 545AS	SX 545SS	SX 545AT	SX 545ST
5.0 MHz	60°	SX 560AS	SX 560SS	SX 560AT	SX 560ST
5.0 MHz	70°	SX 570AS	SX 570SS	SX 570AT	SX 570ST
10.0 MHz	35°	SX 1035AS	SX 1035SS	SX 1035AT	SX 1035ST
10.0 MHz	45°	SX 1045AS	SX 1045SS	SX 1045AT	SX 1045ST
10.0 MHz	60°	SX 1060AS	SX 1060SS	SX 1060AT	SX 1060ST
10.0 MHz	70°	SX 1070AS	SX 1070SS	SX 1070AT	SX 1070ST



Subminiature



Top mount connector



Side mount connector

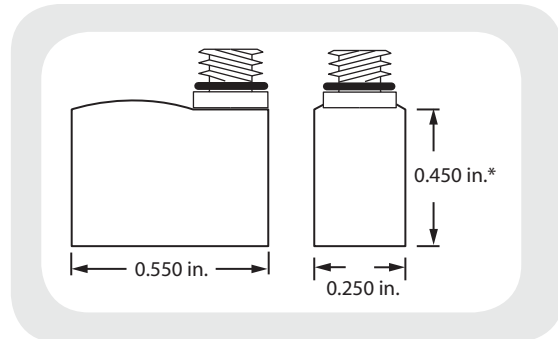
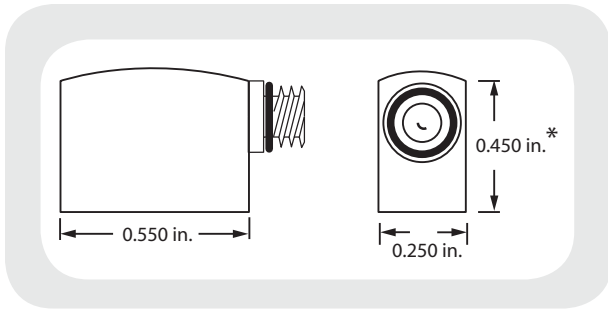

Element		Subminiature with Side Mount Connector		Subminiature with Top Mount Connector	
		Part Number		Part Number	
Frequency	Angle	Aluminum	Steel	Aluminum	Steel
2.25 MHz	35°	SUSM 235AS	SUSM 235SS	SUSM 235AT	SUSM 235ST
2.25 MHz	45°	SUSM 245AS	SUSM 245SS	SUSM 245AT	SUSM 245ST
2.25 MHz	60°	SUSM 260AS	SUSM 260SS	SUSM 260AT	SUSM 260ST
2.25 MHz	70°	SUSM 270AS	SUSM 270SS	SUSM 270AT	SUSM 270ST
2.25 MHz	90°	SUSM 290AS	SUSM 290SS	SUSM 290AT	SUSM 290ST
5.0 MHz	35°	SUSM 535AS	SUSM 535SS	SUSM 535AT	SUSM 535ST
5.0 MHz	45°	SUSM 545AS	SUSM 545SS	SUSM 545AT	SUSM 545ST
5.0 MHz	60°	SUSM 560AS	SUSM 560SS	SUSM 560AT	SUSM 560ST
5.0 MHz	70°	SUSM 570AS	SUSM 570SS	SUSM 570AT	SUSM 570ST
5.0 MHz	90°	SUSM 590AS	SUSM 590SS	SUSM 590AT	SUSM 590ST
10.0 MHz	35°	SUSM 1035AS	SUSM 1035SS	SUSM 1035AT	SUSM 1035ST
10.0 MHz	45°	SUSM 1045AS	SUSM 1045SS	SUSM 1045AT	SUSM 1045ST
10.0 MHz	60°	SUSM 1060AS	SUSM 1060SS	SUSM 1060AT	SUSM 1060ST
10.0 MHz	70°	SUSM 1070AS	SUSM 1070SS	SUSM 1070AT	SUSM 1070ST
10.0 MHz	90°	SUSM 1090AS	SUSM 1090SS	SUSM 1090AT	SUSM 1090ST

Miniature



Side mount connector



Top mount connector

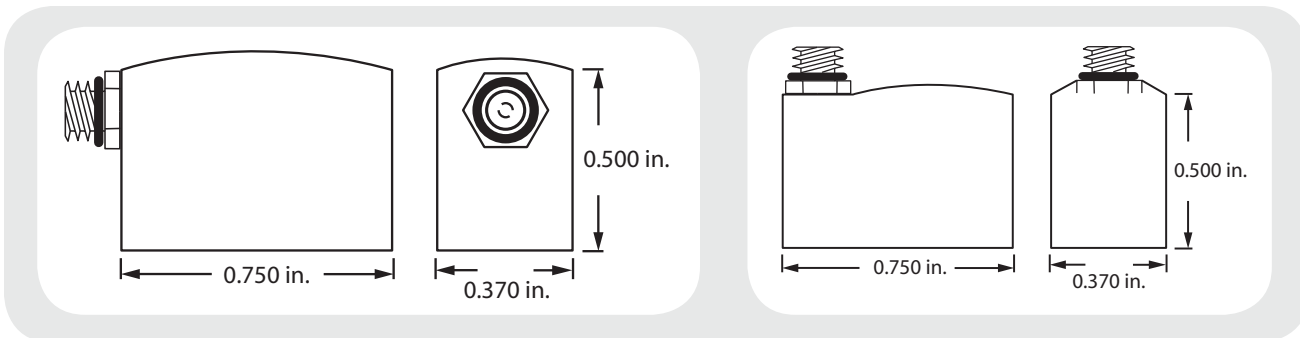

Element		Miniature with Side Mount Connector		Miniature with Top Mount Connector	
		Part Number		Part Number	
Frequency	Angle	Aluminum	Steel	Aluminum	Steel
2.25 MHz	35°	SUM 235AS	SUM 235SS	SUM 235AT	SUM 235ST
2.25 MHz	45°	SUM 245AS	SUM 245SS	SUM 245AT	SUM 245ST
2.25 MHz	60°	SUM 260AS	SUM 260SS	SUM 260AT	SUM 260ST
2.25 MHz	70°	SUM 270AS	SUM 270SS	SUM 270AT	SUM 270ST
2.25 MHz	90°	SUM 290AS	SUM 290SS	SUM 290AT	SUM 290ST
5.0 MHz	35°	SUM 535AS	SUM 535SS	SUM 535AT	SUM 535ST
5.0 MHz	45°	SUM 545AS	SUM 545SS	SUM 545AT	SUM 545ST
5.0 MHz	60°	SUM 560AS	SUM 560SS	SUM 560AT	SUM 560ST
5.0 MHz	70°	SUM 570AS	SUM 570SS	SUM 570AT	SUM 570ST
5.0 MHz	90°	SUM 590AS	SUM 590SS	SUM 590AT	SUM 590ST
10.0 MHz	35°	SUM 1035AS	SUM 1035SS	SUM 1035AT	SUM 1035ST
10.0 MHz	45°	SUM 1045AS	SUM 1045SS	SUM 1045AT	SUM 1045ST
10.0 MHz	60°	SUM 1060AS	SUM 1060SS	SUM 1060AT	SUM 1060ST
10.0 MHz	70°	SUM 1070AS	SUM 1070SS	SUM 1070AT	SUM 1070ST
10.0 MHz	90°	SUM 1090AS	SUM 1090SS	SUM 1090AT	SUM 1090ST



0.375 in. Element

0.500 in. Element

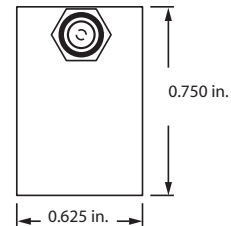
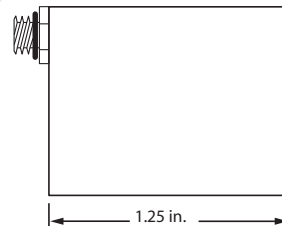
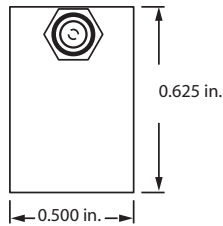
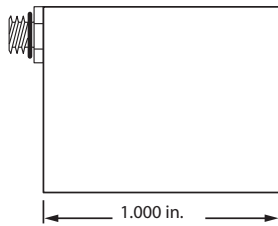

To configure with top mount connector, replace "S" at the end of part number with a "T".

Element		Shear Wave Transducers			
		0.375 in. Element		0.500 in. Element	
		Part number		Part number	
Frequency	Angle	Aluminum	Steel	Aluminum	Steel
2.25 MHz	35°	SU 235AS	SU 235SS	S 235AS	S 235SS
2.25 MHz	45°	SU 245AS	SU 245SS	S 245AS	S 245SS
2.25 MHz	60°	SU 260AS	SU 260SS	S 260AS	S 260SS
2.25 MHz	70°	SU 270AS	SU 270SS	S 270AS	S 270SS
2.25 MHz	90°	SU 290AS	SU 290SS	S 290AS	S 290SS
5.0 MHz	35°	SU 535AS	SU 535SS	S 535AS	S 535SS
5.0 MHz	45°	SU 545AS	SU 545SS	S 545AS	S 545SS
5.0 MHz	60°	SU 560AS	SU 560SS	S 560AS	S 560SS
5.0 MHz	70°	SU 570AS	SU 570SS	S 570AS	S 570SS
5.0 MHz	90°	SU 590AS	SU 590SS	S 590AS	S 590SS
10.0 MHz	35°	SU 1035AS	SU 1035SS	S 1035AS	S 1035SS
10.0 MHz	45°	SU 1045AS	SU 1045SS	S 1045AS	S 1045SS
10.0 MHz	60°	SU 1060AS	SU 1060SS	S 1060AS	S 1060SS
10.0 MHz	70°	SU 1070AS	SU 1070SS	S 1070AS	S 1070SS
10.0 MHz	90°	SU 1090AS	SU 1090SS	S 1090AS	S 1090SS

SwiftChange™ Transducers and Wedges

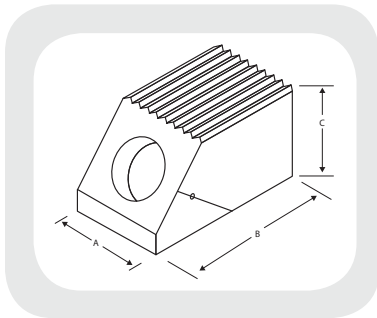
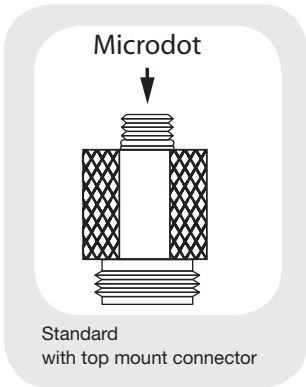
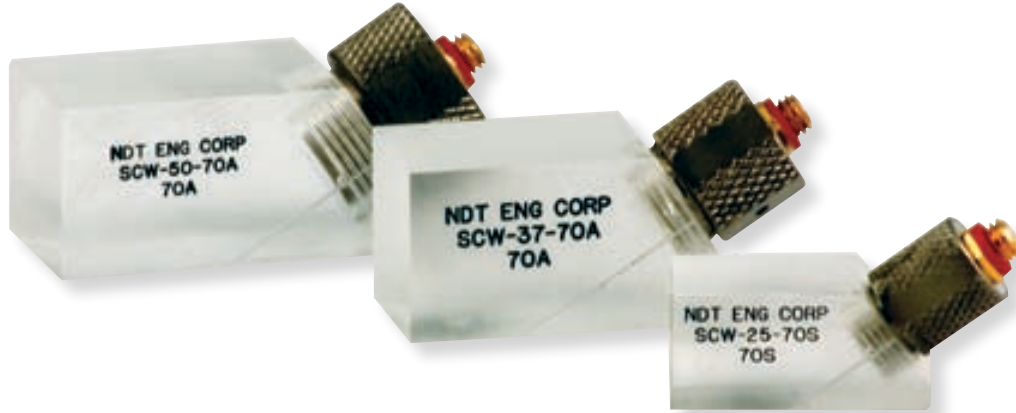

Wedge Dimensions (in in.)				
Element size	Refracted angle	A	B	C
0.250 in.	45°	.55	.64	.50
	60°	.55	.81	.55
	70°	.55	.97	.58
	90°	.55	1.10	.63
0.375 in.	45°	.69	.81	.53
	60°	.69	1.06	.63
	70°	.69	1.20	.69
	90°	.69	1.38	.70
0.500 in.	45°	.81	1.0	.63
	60°	.81	1.21	.72
	70°	.81	1.44	.75
	90°	.81	1.63	.79

Frequency	Element Size	SwiftChange™ Transducers
		Standard with Top Mount Connector
		Part Number
1.0 MHz	0.250 in.	SCT 125
1.0 MHz	0.375 in.	SCT 137
1.0 MHz	0.500 in.	SCT 150
2.25 MHz	0.250 in.	SCT 225
2.25 MHz	0.375 in.	SCT 237
2.25 MHz	0.500 in.	SCT 250
5.0 MHz	0.250 in.	SCT 525
5.0 MHz	0.375 in.	SCT 537
5.0 MHz	0.500 in.	SCT 550
10.0 MHz	0.250 in.	SCT 1025
10.0 MHz	0.375 in.	SCT 1037
10.0 MHz	0.500 in.	SCT 1050

Shear Angle	Wedge for ¼ in. Element Transducer		Wedge for ⅜ in. Element Transducer		Wedge for ½ in. Element Transducer	
	Part Number		Part Number		Part Number	
	Aluminum	Steel	Aluminum	Steel	Aluminum	Steel
30°	SCT-25-30A	SCT-25-30S	SCT-37-30A	SCT-37-30S	SCT-50-30A	SCT-50-30S
35°	SCT-25-35A	SCT-25-35S	SCT-25-35A	SCT-25-35S	SCT-25-35A	SCT-25-35S
40°	SCT-25-40A	SCT-25-40S	SCT-25-40A	SCT-25-40S	SCT-25-40A	SCT-25-40S
45°	SCT-25-45A	SCT-25-45S	SCT-25-45A	SCT-25-45S	SCT-25-45A	SCT-25-45S
50°	SCT-25-50A	SCT-25-50S	SCT-25-50A	SCT-25-50S	SCT-25-50A	SCT-25-50S
60°	SCT-25-60A	SCT-25-60S	SCT-25-60A	SCT-25-60S	SCT-25-60A	SCT-25-60S
70°	SCT-25-70A	SCT-25-70S	SCT-25-70A	SCT-25-70S	SCT-25-70A	SCT-25-70S
80°	SCT-25-80A	SCT-25-80S	SCT-25-80A	SCT-25-80S	SCT-25-80A	SCT-25-80S
90°	SCT-25-90A	SCT-25-90S	SCT-25-90A	SCT-25-90S	SCT-25-90A	SCT-25-90S

Immersion Transducers

Standard and Slim-Line

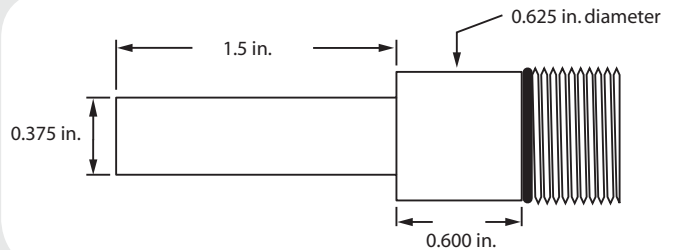
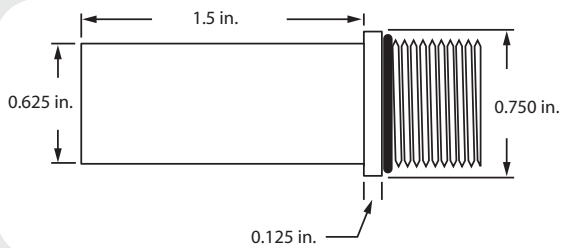

Frequency	Standard Immersion Transducers			
	0.187 in. Element	0.250 in. Element	0.375 in. Element	0.500 in. Element
1.0 MHz	SUI 118	SUI 125	SUI 137	SUI 150
2.25 MHz	SUI 218	SUI 225	SUI 237	SUI 250
5.0 MHz	SUI 518	SUI 525	SUI 537	SUI 550
10.0 MHz	SUI 1018	SUI 1025	SUI 1037	SUI 1050
15.0 MHz	SUI 1518	SUI 1525	SUI 1537	SUI 1550
20–25 MHz	SUI 2018	SUI 2025	SUI 2037	SUI 2050

Frequency	Slim-line Immersion Transducers	
	0.187 in. Element	0.250 in. Element
1.0 MHz	SUSI 118	SUSI 125
2.25 MHz	SUSI 218	SUSI 225
5.0 MHz	SUSI 518	SUSI 525
10.0 MHz	SUSI 1018	SUSI 1025
15.0 MHz	SUSI 1518	SUSI 1525
20–25 MHz	SUSI 2018	SUSI 2025

Cables, Kits, and Miscellaneous UT Accessories

Cables and Extensions

Custom Kits and Guides



NDT Engineering Corporation remains highly dedicated to its position as a leading provider of custom made UT kits, which include certified transducers, reference standards, and guides. This means that we can work with you on any special project at no additional cost until a workable solution has been achieved. In addition to providing guides and positioners for all major airplane manufacturers, we have also been responsible for projects on the military aircraft listed in the following table:

<i>Cables and extensions</i>		
Description	Part Number	Length
6 ft BNC to Microdot	CBM-6	6 ft
12 ft BNC to Microdot	CBM-12	12 ft
15 ft BNC to Microdot	CBM-15	15 ft
6 ft BNC to right-angle Microdot	CBMR-6	6 ft
12 ft BNC to right-angle Microdot	CBMR-12	12 ft
15 ft BNC to right-angle Microdot	CBMR-15	15 ft
6 ft BNC to BNC	CBB-6	6 ft
12 ft BNC to BNC	CBB-12	12 ft
6 ft miniature Microdot to BNC	CBMM-6	6 ft
6 ft dual BNCs to dual Microdots	C2BM-MSE-6	6 ft
6 ft dual BNCs to 2-pin Microdot	C2BN-2M-6	6 ft
10 in. female Microdot to male right-angle Microdot	AMF-MR-10	10 in.
10 in. female Microdot to male Microdot	AMF-M-10	10 in.



Transducer Certification

Approved techniques and instrumentation are used to supply waveform, damping factor, frequency spectrum, and beam profiles. Customers requiring certification of transducers should specify the type of certification, as described below, when ordering.

Certification Level 1

- Certificate of conformance by letter

Certification Level 2

- Waveform analysis
- Frequency spectrum analysis

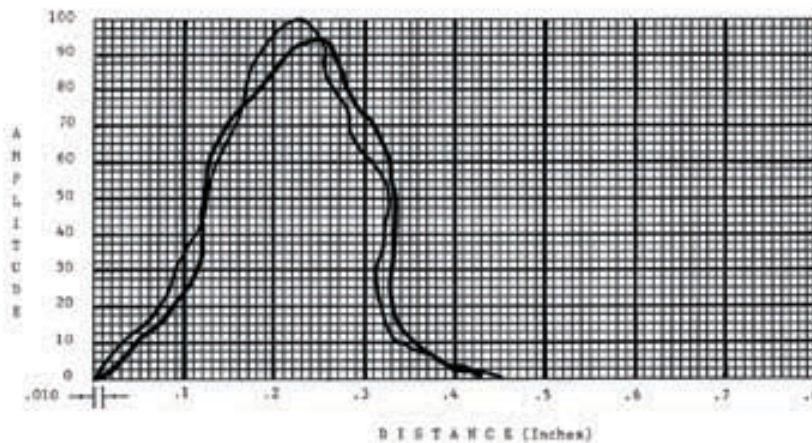
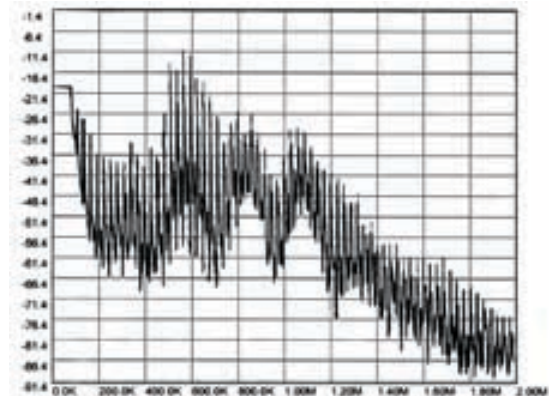
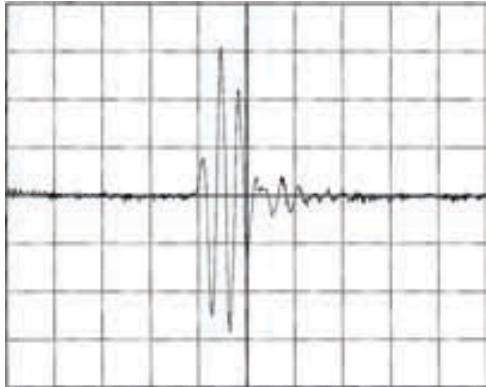

Note: Certification is a method to show transducer performance. Please refer to the inspection procedure for the proper instrument setup for your inspection.

Roller Probes, Yokes, and Gimbals

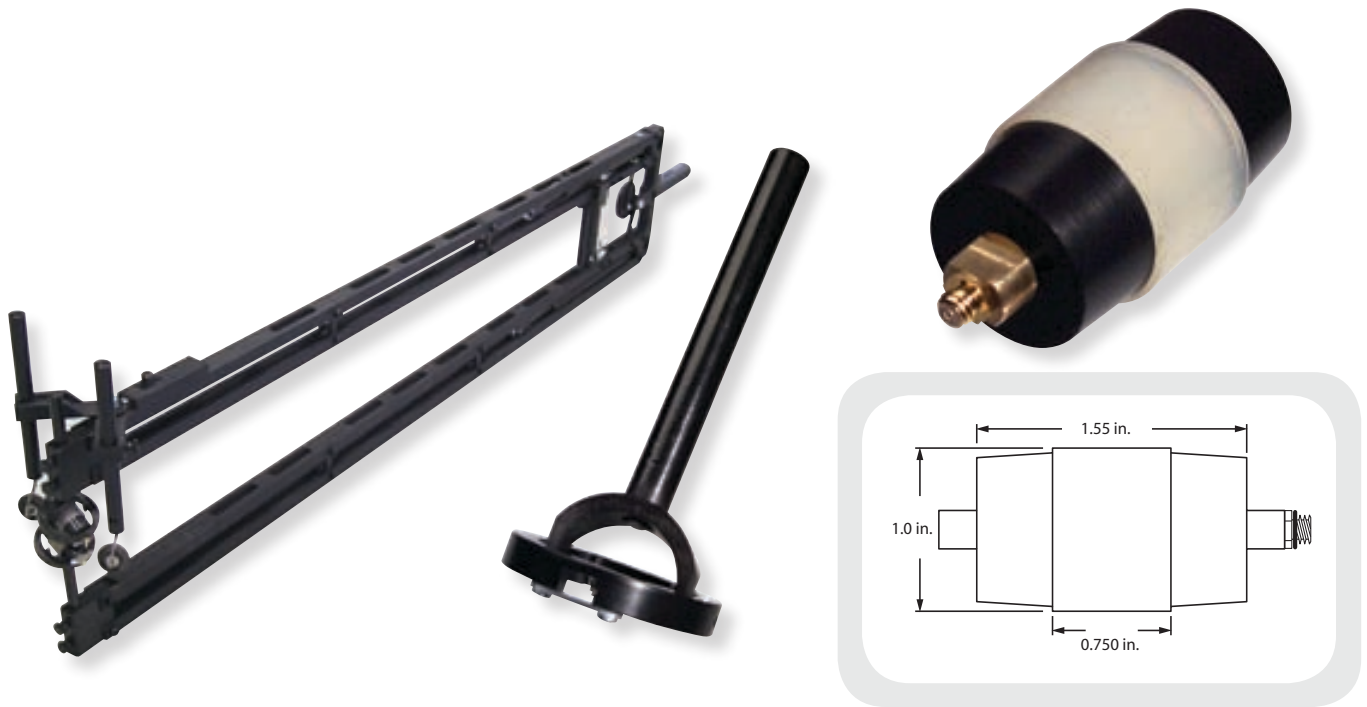

Roller probe yokes, though limited in application, offer the considerable advantage of eliminating the inconvenience of water required with jet yokes. The design of the roller probe yokes has been extensively improved to meet US Air Force requirements. The current design is unique in that it provides constant roller probe contact pressure and alignment throughout inspection of widely varying material thicknesses up to the limits of the yoke opening.

Roller probe yokes are shipped with two cables BNC to right-angle Microdot number CBMR-12 (see page 46). Roller probes and gimbals are separate unless purchased as part of a kit.

Type	Roller Probe Yokes		
	Part Number	Throat Length	Throat Width
Roller probe yoke only	RPTW-242A	24 in.	10–20 in.
	RPTW-322A	32 in.	10–20 in.
	RPTW-362A	36 in.	10–20 in.
	RPTW-402A	40 in.	10–30 in.
	RPTW-482A	48 in.	10–30 in.
Roller probe yoke kits	RPTWK-242A	24 in.	10–20 in.
	RPTWK-322A	32 in.	10–20 in.
	RPTWK-402A	40 in.	10–30 in.

Roller Probes		
Part Number	Frequency	Element Size
DCR-581	1.0 MHz	0.375 in. × 0.500 in.
DCR-582	1.0 MHz	0.375 in. × 0.750 in.
DCR-583	2.25 MHz	0.375 in. × 0.500 in.
DCR-584	2.25 MHz	0.375 in. × 0.750 in.
DCR-585	5.0 MHz	0.375 in. × 0.500 in.
DCR-586	5.0 MHz	0.375 in. × 0.750 in.

Roller Probe Gimbals	
Part Number	Description
GA-581	Fits all DCR roller probes and RPTW roller probe yokes.



Waterjet Yokes, Nozzles, and Nozzle Transducers



Handheld waterjet yokes, also called wands, provide a simple, cost-effective means of inspecting composites and bonded structures. Although the most common application is for the inspection of small parts and details not easily or efficiently inspected with the large scanning systems, field inspection of installed structures can be performed as well.

Yokes are supplied with two nozzles (JTN 1.5 × 0.75 —nozzles and two CBMR-12 cables (cables found on page 50).

Transducers are designed to fit all nozzles. They are interchangeable, and frequencies ranging from 0.5 MHz to 5.0 MHz are available. The most commonly used frequency for TTU applications is 1.0 MHz.

Type	Waterjet Yoke			
	Part Number	Throat Length	Throat Gap	Nozzle Gap (Approximate)
Fixed length and width	JTW-12/6	12 in.	6 in.	3 in.
	JTW-24/6	24 in.	6 in.	3 in.
	JTW-30/8	30 in.	8 in.	5 in.
	JTW-36/8	36 in.	8 in.	5 in.
	JTW-42/8	42 in.	8 in.	5 in.
Variable length and width	JTWX-14/10	14 in.	Adjusts to 10 in.	7 in.
	JTWX-30/14	30 in.	Adjusts to 14 in.	11 in.
	JTWX-40/17	40 in.	Adjusts to 17 in.	14 in.

Nozzles			
Part Number	Dimensions		Replacement Tip Part Number
	Height	Diameter	
JTN-501/xxx	1.6 in.	0.800 in.	JI-501/xxx
JTN-5	1.6 in.	0.850 in.	JI-5
JTN-70V/xxx	2.0 in.	1.0 in.	JI-70V/xxx

OPTIONS: xxx is required inside the diameter of nozzle tip in choices of 0.125 in., 0.187 in. and 0.250 in.

Nozzle Transducers		
Part Number	Frequency	Element Diameter
JA4-.5/.5	0.5 MHz	0.5 in.
JA4-1.0/.5	1.0 MHz	0.5 in.
JA4-2.25/.5	2.25 MHz	0.5 in.
JA4-5.0/.5	5.0 MHz	0.5 in.

Reference Standards

Aircraft Standards



<i>Boeing</i>	
Aircraft	Series Part Numbers
Boeing 707	See NTM
Boeing 727	See NTM
Boeing 737	See NTM
Boeing 747	See NTM
Boeing 757	See NTM
Boeing 767	See NTM
Boeing 777	See NTM

Note: Manufacturers continually add new reference standard numbers. Please contact our sales department for updated lists.

<i>Douglas</i>	
Aircraft	Series Part Numbers
DC-10	10RS.01 through 10RS.50
DC-9	9RS1 through 9RS35, 9RST1 through 9RST8
DC-8	See NTM
MD-80 Series	See NTM
MD-90	See NTM
MD-11	See NTM

<i>Airbus</i>	
Aircraft	Series Part Numbers*
Airbus A300	See A300 NTM
Airbus A300-600	See A300-600 NTM
Airbus A310	See A310 NTM
Airbus A318, A319, A320, A321	See A318 NTM, A319 NTM, A320 NTM, and A321 NTM
Airbus A320	See A320 NTM
Airbus A330	See A330 NTM
Airbus A340	See A340 NTM

* Each series is nonspecific and found in the NDI Manuals for all aircraft listed.
 Note: Manufacturers continually add new reference standard numbers.
 Please contact our sales department for updated lists.

Other Manufacturers

NDT Engineering Corporation can manufacture reference standards for any aircraft manufacturer. Due to low demand we don't carry full maintenance manuals on these aircraft.

Drawings may be required to ensure you receive the most current revision.

<i>Other Aircraft</i>
ATR
Cessna
Embraer
Fairchild
Falcon
Fokker
Gulfstream
Hawker
BAE Aerospace
Jetstream
Learjet/Bombardier
Lockheed
Boeing Helicopter
Metro
SAAB
Sikorsky
Bell Helicopter
All military aircraft



Hole Standards

Surface Standards

MHS-12-1A-0



SRS-0824S

Material options

Add to the end of the part number

- A: 2024 or 7075 aluminum
- S: 4130 or 4340 steel
- T: 6AL4V titanium
- SS: 304 stainless steel
- I: Inconel®
- Other alloys available upon request

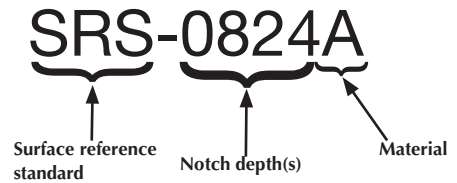
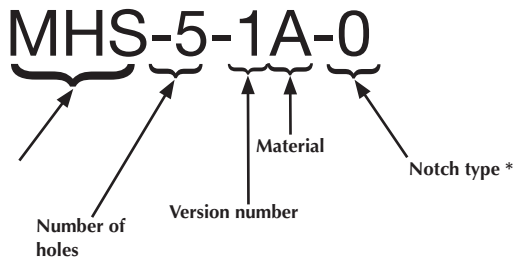

*Notch types

-0	0.030 in. × 0.030 in. corner notch
-1	0.020 in. deep, notch runs the full length of ID
-2	Both -0 and -1 type notches

Notch depths

1st	1 Notch reference standard
1st and 2nd	2 Notch reference standard
1st, 2nd, 3rd	3 Notch reference standard

Notches can be supplied in millimeters if requested

Hole Standards		
Part number	Holes	Configuration
MHS-5-2A-0	5	7/16 in., 1/2 in., 5/16 in., 3/4 in., 1.0 in.
MHS-8-1A-0	8	1/8 in. to 3/16 in. × 1/16 in. increments
MHS-10-1A-0	10	1/8 in. to 1/2 in. × 1/16 in. and 3/16 in., 5/8 in., 3/4 in.
MHS-12-1A-0	12	3/16 in. to 3/8 in. × 1/32 in. and 7/16 in., 1/2 in., 5/16 in., 5/8 in., 3/4 in.
MHS-29-1A-0	29	1/8 in. to 1.0 in. × 1/32 in. increments

Surface Standards				
Notch Depths			Part Number	
1st	2nd	3rd	Aluminum	Steel
0.010 in.			SRS-1A	SRS-1S
0.020 in.			SRS-2A	SRS-2S
0.030 in.			SRS-3A	SRS-3S
0.040 in.			SRS-4A	SRS-4S
0.005 in.	0.008 in.		SRS-0508A	SRS-0508S
0.005 in.	0.010 in.		SRS-051A	SRS-051S
0.008 in.	0.020 in.		SRS-082A	SRS-082S
0.010 in.	0.020 in.		SRS-12A	SRS-12S
0.005 in.	0.010 in.	0.020 in.	SRS-0512A	SRS-0512S
0.008 in.	0.010 in.	0.020 in.	SRS-0812A	SRS-0812S
0.008 in.	0.010 in.	0.030 in.	SRS-0813A	SRS-0813S
0.008 in.	0.010 in.	0.040 in.	SRS-0814A	SRS-0814S
0.008 in.	0.020 in.	0.040 in.	SRS-0824A	SRS-0824S

Ultrasonic Standards



<i>Reference Standards</i>	
Part number	Description
IIW Type 1	Calibration of shear and longitudinal TD's
IIW Type 2	Modified version of IIW Type 1
MAB (mini angle block)	General angle beam calibration
TRS-5-1A	Thickness and linearity calibration
TRS-4-1S	Thickness and linearity calibration
Type DSC	Shear wave distance and sensitivity
Navship	NAVSHIPS spec 0900-006-3010
AWS Resolution	Resolution of angle beam TD's
30 FBH Resolution	Produce area/amplitude plots
ASME N-625	Shear, longitudinal, and surface sensitivity
IOW Beam Profile	Beam profile measurement
Miniature Resolution	Calibrating high-resolution equipment
Type DC	Shear wave distance calibration
Type SC	Shear wave sensitivity calibration
Type DS	Longitudinal distance and sensitivity
Area/Amplitude	Set of 8 ASTM blocks
Distance/Area Amplitude	Set of 10 ASTM blocks
Distance Amplitude	Set of 19 ASTM blocks
Structural types	Supplied for all aircraft manufacturers.



Composite Standards

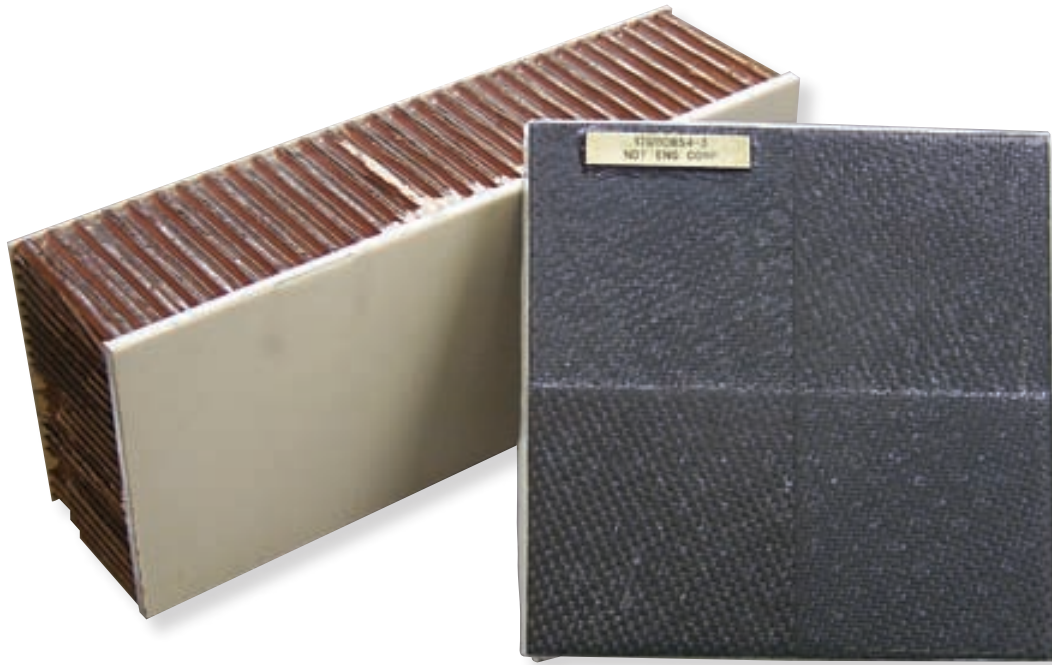

<i>Composite Standards</i>		
Part Number	Airplane	Description
ST8870-1 and -4	Boeing General Purpose	GR/EP skin /NOMEX core disbond reference defect
ST8870-7, -8, -9	Boeing General Purpose	GR/EP laminate step thickness standard
99D55109001000	Airbus General Purpose	GR/EP set of laminate step thickness standards (tape)
99D51407291001	Airbus General Purpose	GR/EP set of laminate step thickness standards (fabric)
C12-DIS-3C1N	Boeing General Purpose	GR/EP laminate step disbond and core laminate interface
C12-PCS-3C1N	Boeing General Purpose	GR/EP laminate step potted core and splice core defect
C12-DEL-3C1N	Boeing General Purpose	GR/EP skin /H.C. core disbond reference defect
C12-POT-3C1N	Boeing General Purpose	GR/EP skin /H.C. core disbond reference defect
NDT 1033-10	Boeing General Purpose	Alum to alum skin: 100 thickness combos with sim disbond defects
NDT 1046	Boeing General Purpose	GR/EP stepdown 6/3 ply step thickness on H.C. core
NDT 2001	Boeing 727	Aluminum skin and H.C. core with disbond reference defect
NDT 4150	Boeing 747	Fiberglass Prereg H.C. panel with disbond reference defect
17G110830-3	C-17	GR/EP variable ply thickness on NOMEX core
17G110830-23	C-17	GR/EP skins with NOMEX core-1 in. dia. disbond reference defects
17G110854-3	C-17	GR/EP variable ply skins on foam core with 1 in. dia. disbond reference defects

Eddy Current Tutorial and Probe Selection Information

The selection of the right eddy current probe is of great importance in the success of your inspection. In these pages, we have included useful information to help you make the right choice.

Single-Coil Probes

The earliest instruments used in aircraft inspection included the Magnaflux ED-500 and ED520, and the Foerster Defectometer (although not a bridge type instrument but a resonant circuit type), all of which used single-coil probes. The probes contain a single coil that is wound to a specific value. No other coil is needed. More recently, the introduction of the Hocking Locator and newer models of the Foerster Defectometer have kept this kind of instrument as a popular option for many users. When these probes are used with a bridge circuit type instrument, a balance coil is also required. Balance coils are normally placed in the cable connector or a separate adapter (see Fig. 1).

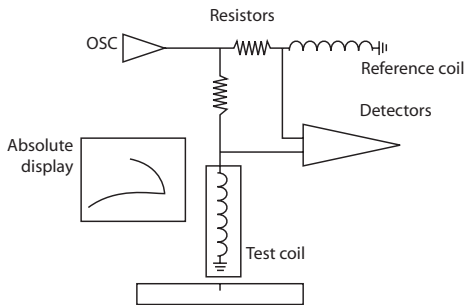

Fig. 1

It sometimes creates a problem when the probe inductance value is not close enough to the value of the balance coil, and the instrument does not balance correctly. This happens more often when they are not made by the same manufacturer. The result is poor performance (noisy or insensitive) or no response at all (signal saturation).

Bridge Type Probes

In this configuration the probe coils are located in an electrical "bridge" (see fig. 2). The instrument balances the bridge and any change in balance is displayed as a signal.

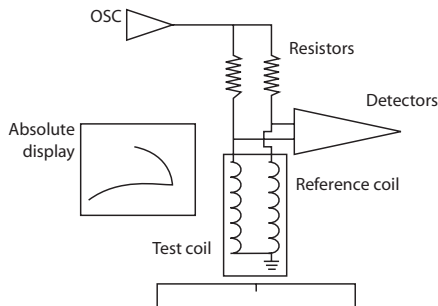

Fig. 2

In this arrangement, the same coil produces the eddy currents and detects the impedance changes caused by the defects (or any other variables). Almost all instruments are able to operate with this type of coil arrangement.

Reflection Type Probe

These probes are also known as send-receive or driver-pickup. In this configuration, the eddy currents are produced by a coil connected to the instrument's oscillator (driver).

The signals received back in the probe are detected by separate coils called pickups (see Fig. 3 and Fig. 4).

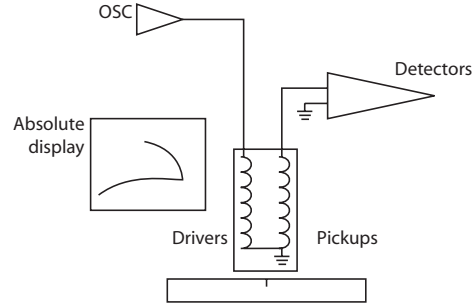

Fig. 3

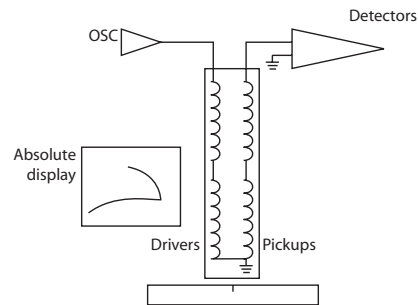

Fig. 4

All new impedance plane instruments and also many older models are able to operate in both bridge and reflection modes. If you are in doubt, call the manufacturer or give us a call.

Bridge or Reflection?

This is a common question asked by those involved in trying to select the best probe for an inspection. The answer is "It depends." Let us consider both systems.

Gain. Reflection probes will give a higher gain, particularly if they are "tuned" to a specific frequency, but normally the difference is on average about 6 dB. It is true that this doubles the signal, but if you consider that the instruments are able to give this increase of gain easily, it is not so important. Nevertheless, in critical applications this increase is very welcomed.

Frequency range. Reflection probes do not need to balance the driver to the pickup coils. This means that they will give a wider frequency range. As long as the driver produces eddy currents, the pickup will detect them and some signal will be displayed. This may not provide good information at certain frequencies, but the probe is still working!

Bridge type probes used to give a limited frequency span in the older instruments, as these had to balance an electrical bridge using its other arms (X and R controls). In modern instruments, the bridge is normally formed with fixed precision resistors, or a fixed transformer inside it. The signals detected in this manner are electronically processed without any "mechanical" adjustments, and this means a greater ability to balance over a wider frequency range.

Drift: Probe drift is mostly caused by temperature change in the coils. This may be caused by varying ambient temperature, or the heat produced by the oscillator current, or both. There are design parameters that can be optimized to reduce drift, such as wire diameter and ferrite selection, but reflection probes are normally a good choice to avoid this problem even more.

In a reflection probe, the driver current does not flow through the pickup coils; in fact, the magnetic field received back from the specimen is normally much smaller and, consequently, the current flowing in the pickups is also reduced. Most probe types (pencil, spot, ring, bolt hole, etc.) can be made as bridge or reflection. Keep in mind that a reflection probe is almost invariably more difficult to manufacture and therefore more expensive.

Absolute and Differential Probes

This is an area where some confusion exists. Many users have called a probe "differential" when the signal displayed gives an up and down movement or a figure 8 type signal. This is caused by the two coils sensing the defect in sequence. When both sensing coils are on the probe surface, they compensate for lift-off and as a result no line is visible (see Fig. 5).

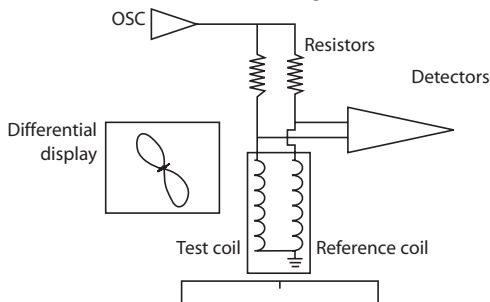

Fig. 5

In contrast, an absolute display is produced by a single sensing coil (see Fig. 1 through Fig. 4), giving a single, upward movement with a near horizontal lift-off line.

Others have called a probe "differential" simply when the coils were connected differentially such as in a bridge circuit. The problem with this definition is that probes can be connected differentially in a reflection system as well as when using two pickups (such as most scanner-driven bolt hole probes). In this case, the two pickup coils are positioned close to one another and contained within a driver coil (see Fig. 6).

The best way out of this confusion is often to specify the probe as bridge-differential, absolute, or reflection-differential-absolute as needed. It seems to make more sense to qualify the description according to the displayed signal, since this is what really matters. Not many people are concerned as to how the coils are connected internally.

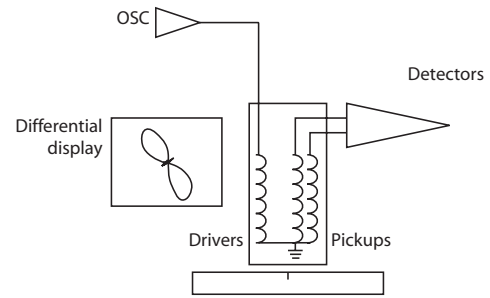

Fig. 6

Shielded and Unshielded Probes

Probes are normally available in both shielded and unshielded versions; however, there is an increasing demand for the shielded variety. Shielding restricts the magnetic field produced by the coils to the physical size of the probe or even less. A shield can be made of various materials, but the ones mostly used are: ferrite (like a ceramic made of iron oxides), Mumetal®, and mild steel.

Ferrites make the best shields because they provide an easy path for the magnetic field but have poor conductivity. This means that there are few eddy current losses in the shield itself. Mild steel has more losses but is widely used for spot probes and ring probes due to its machinability and when ferrites are not available in certain sizes or shapes. Mumetal® is used sometimes for pencil probes as it is available in thin sheet; however, it is less effective than ferrite.

Shielding has several advantages: first, it allows the probe to move in (or close to) geometry changes, such as edges, without giving false indications; next, it allows the probe to touch ferrous fastener heads with minimal interference; last, it allows the detection of smaller defects due to the stronger magnetic field concentrated in a smaller area.

On the other hand, unshielded probes allow somewhat deeper penetration due to the larger magnetic field. They are also slightly more tolerant to lift-off. Unshielded probes are recommended for the inspection of ferrous materials (steel) for surface cracks, and in particular with meter instruments. The reason for this is that the meter response is too slow to allow the signal from a shielded probe to be displayed at normal scanning speeds due to the smaller sensitive area.

Adapters

To connect a probe with a connector different from the type used in the instrument, it is necessary to use an adapter. An adapter consists of two different connectors joined and wired to match the inputs and outputs as necessary. It is normally housed in a short body that can be positioned at the instrument's input. Sometimes, it is also possible to have a "cable adapter," which is made to match a connector located at the probe body. Depending on the instrument's wiring, it may be possible to have a single adapter for both bridge and reflection. In other cases, it is necessary to have two separate adapters or use a switchable type.

Probe Types and Their Usage

Pencil Surface Probes

These are the probes normally used for surface crack detection, also known as high frequency eddy current probes (HFEC). They have a small coil that can be made shielded or unshielded. Most are absolute types, although they can be made with the balance coil built into the probe body to ensure good balance and increase frequency range. There are many types available, both in straight and angled versions, to match any requirements. They are also available with "flex" shafts that can be adjusted to different shapes.

Pencil probes can be designed to operate at various frequencies, depending mostly on the material to be tested. For aluminum, 100 kHz is the most popular, allowing use of up to 200 kHz or more, depending on the balance coil and the instrument used. The higher frequencies will give better angle to lift-off, although as the probe approaches 500 kHz it becomes more lift-off sensitive and will not penetrate as much material. Because of this, it is normally preferable to stay at lower frequencies.

It has become common to use pencil probes below 100 kHz when looking for first layer cracks that originate in the opposite side and are growing, but have not broken the surface yet (even more so with clad skins). A frequency between 20 kHz and 50 kHz will penetrate the clad and detect a defect that is only 50% through the thickness. Some standard 100-kHz probes can be run at 50 kHz provided that we compensate for this by using higher gains; however, it is better to use probes designed for the lower frequencies, even if we have to accept a slightly larger diameter.

For low-conductivity materials, such as titanium or stainless steel, it is necessary to choose a frequency of 1 MHz to 2 MHz to improve sensitivity and phase angle to surface breaking cracks. Magnetic steels are not very critical as far as frequency is concerned, although good results are often obtained at 1 MHz or 2 MHz to minimize permeability variations. When the material is cadmium-plated, lower frequencies are needed to minimize its effect and sometimes a frequency of 25 kHz to 50 kHz is the best, although a bigger probe diameter is required.

Surface Spot Probes

Also known as low-frequency eddy current probes (LFEC), spot probes are used at low frequencies for subsurface detection of cracks and/or corrosion. They are available from 100 Hz and up (to penetrate the thicker structures), in both shielded and unshielded versions. Shielded probes are more popular as they concentrate the magnetic field under the probe and avoid interference from edges and other structures; however, they are more sensitive to small defects. Reflection types are also widely used due to the lower drift and often higher gain in the more demanding applications. Spring-loaded bodies are useful to maintain a constant pressure when needed, such as when spot testing for conductivity differences.

Ring/Encircling Probes

These are similar to the surface spot probes, except that the center has been enlarged (and made into a hole) to accept the diameter of the fastener head/hole to be inspected. They provide greater sensitivity to cracks, as the fastener/hole interface aids the penetration. This is even more noticeable with ferrous fasteners, but permeability variations can also give problems. The probe internal diameter (ID) is the more important dimension, and

should be chosen to be slightly bigger than the fastener head. The outside diameter (OD) is not normally critical but it should not overlap other fastener heads. The probe height is not critical; however, in cases of limited access, special low-profile types are available where the test and balance sections are separated to further reduce the height.

Bolt Hole Probes

Bolt hole probes are designed to inspect the bore of holes after the fastener is removed. They can be divided into two groups:

Manually operated with adjustable collar. The probe is indexed to the right depth and rotated manually.

Rotating scanner. These are made to match the various scanners in use, and provide the best coverage and high inspection speeds. Both types can be made with absolute or differential coils. The differential coils are less sensitive to interface and provide better detection of defects. They normally operate in the reflection mode.

Two new hole probe types have been recently developed that have dramatically improved bolt hole inspection. The first of these rotary types is the large diameter probes which allow the inspection of holes that previously could only be accomplished with manually operated types. The second of these new rotary types is the adjustable diameter probes. These types reduce drastically the number of probes needed to inspect a wide range of diameters. These are extremely useful during reaming operations as the instrument does not require recalibration. Normally the instrument would be recalibrated every time the probe is changed, thus requiring a large number of calibration standards.

Other Hole Inspection Probes

Low frequency bolt hole probes. To inspect holes through bushings, low frequency coils can be used. These probes use coils similar to those in the surface spot probes.

Countersink probes. These are made to fit specific fastener head shapes to inspect the open hole entrance. They can be made for manual or rotating scanner operation, with the same absolute or differential coils used in the standard bolt hole inspection. If a large number of holes need inspection, the rotating scanner type provides a much faster coverage.

Large Diameter Rotating Scanner Probes

For many years, large diameter holes have been inspected using manual bolt hole probes. The reason for this was that the existing probe designs were too heavy and unbalanced to rotate freely for use with standard handheld rotating scanners. Manual scanning and indexing is not only a slow process, but it is also difficult to ensure complete coverage. In addition, large holes are often in thick parts, and that means that a large number of scans are required to cover the complete thickness.

The new large diameter probes have been designed to minimize weight and optimize mechanical balance. In this way, the comparatively small power rotating guns can drive them without excessive speed loss and shaking. Diameters in excess of 2 in. (50 mm) have been successfully tested. The adjustable diameter allows for the probe to be set at the correct diameter to prevent too much friction and yet not lose sensitivity to small defects.

Notes

1. Not all handheld scanners have the same power and the larger diameter probes need more power or the inspection results will be unreliable. If in doubt about your rotating scanner, give us a call and we will advise you.

2. When testing large diameter holes, the coil is traveling faster over the defect. This changes the duration of the signal and means that the filter settings in the instrument may need to be reset to higher values. The high-pass filter (HPF) that normally reduces the effect of slow changing variables, such as ovality (lift-off changes), will not be as effective and the setting will need to be increased, for example, from 100 Hz to 200 Hz or more. The low-pass filter (LPF) may cut part of the defect signal. Again try increasing the setting to avoid this, for example, from 200 Hz to 500 Hz or more. Band-pass filters (BP) are a combination of both and are available in some instruments. They also need resetting to a higher value. Always adjust the filters for the best signal-to-noise ratio. Some instruments may not have enough filter settings to take full advantage of the large diameter probes.

Special Probes

There are many probe types that are made for specific customer requirements. Please send us a drawing or sketch of your application, and we will quote a special eddy current probe to fit your part.

Troubleshooting

When experiencing difficulty in operating a probe, it is advisable to do some simple tests.

√ Check that the operating frequency is within the probe's range. If the probe is not balancing properly, the instrument may have entered into "saturation." This can be verified easily. If the signals produced by lift-off and defect (or an edge) superimpose on each other, there is no phase angle and saturation has occurred. The frequency may be too high, or the probe coil and the balance coil are not of the same value. Try lowering the probe drive voltage. Please note that some instruments have the capability of very high output values that may be excessive for some probes.

√ Try moving the cable, particularly where it joins the connector or the probe body as these are the weaker points. If it shows intermittent operation, the cable needs replacement. Also, it may be necessary to clean connector contacts. Silicon spray or an electrical contact cleaner will often help.

√ If the dot appears dead or the signals are small and/or distorted, look at the filter settings. Many instruments now offer a range of "high pass" and "low pass" filters. These are very useful, but if set incorrectly will cause various effects.

High-pass filters (HPF) will always bring the dot to the balance point and, at high settings, (as used for rotating scanners) will make the dot appears as static at the balance point. For hand operation, set the high pass filter to OFF (or 0 Hz).

Low-pass filters (LPF) will make the display speed dependent. The best setting for manual use is typically 100 Hz, but if the signal is too noisy it may be necessary to reduce this setting. If so, the scanning speed will need to be kept low enough as not to reduce the size of the signals.

√ Examine the probe test surface. It may be damaged or worn. Watch for exposed wires or other damages. Use Teflon[®] tape at the probe face whenever possible. This reduces probe wear and also prevents possible contact with the ferrites that will often produce noise.

√ When confronted with high signal-to-noise ratios, it is always a good practise to insert a small piece of sponge or foam rubber to enhance the coil's contact with the inner surface of the hole. This technique will greatly reduce noise and increase sensitivity.

OLYMPUS®

Legal Notices

Olympus and the Olympus logo are registered trademarks of Olympus Corporation. Quickfit is a trademark of NDT Engineering Corporation. 707, 717, 727, 737, 747, 757, 767, 777, B-52 Stratofortress, and KC-135 Stratotanker are trademarks or registered trademarks of The Boeing Company. A-10 is a trademarks of Fairchild Republic Co. A300, A310, A318, A319, A320, A321, A330, A340, A380, and A400M are trademarks or registered trademarks of Airbus S.A.S. A-6 is a trademark of Grumman Aerospace Corporation. AH-64 Apache, DC-9, DC-10, F-15 Eagle, F-15C Eagle, F-15D Eagle, F-15E Strike Eagle, F/A-18 Hornet, McDonnell Douglas, MD-11, MD-80 Series, and MD-90 are trademarks or registered trademarks of Boeing (McDonnell Douglas). C-130 is a trademark of Lockheed Aeronautical Systems Company. C-141 and C-5A are trademarks or registered trademarks of Lockheed-Georgia Co. Challenger and Dash 8 are trademarks or registered trademarks of Bombardier Inc. DC-8 is a trademark of Boeing (Douglas). Elotest is a trademarks of Rohmann GmbH. F-16 Fighting Falcon is a trademark of General Dynamics. Fischer is a registered trademark of W.W. Fischer S.A. Inconel is a registered trademark of Inco Alloys/ Special Metals. LEMO is a registered trademark of LEMO USA, Inc. Magnaflux ED-500 and Magnaflux ED-520 are registered trademarks of Magnaflux. MIZ is a trademark of Zetec Inc. Mumetal is a registered trademark of Goodfellow Corporation. Delrin and NOMEX are registered trademarks of E.I. duPont de Nemours and Company. Nortec is a trademark of Staveley NDT. UH-60 is a trademark of Sikorsky Aircraft.

Any use of any of the marks appearing in the present document without the express written consent of Olympus NDT or the owner of the mark, as appropriate, is strictly prohibited.

Disclaimer

This document was prepared with particular attention to usage to ensure the accuracy of the information contained therein. It corresponds to the version of the products manufactured prior to the date appearing on this page. There may, however, be some differences between the catalog and the products if the products have been modified thereafter.

The information contained in this document (including photographs, drawings, descriptions, and technical data) is subject to change without notice.



NDT Engineering Corporation

19620 Russell Rd.
Kent, WA 98032
USA
Telephone: 1-253-872-3565
Fax: 1-253-872-0857

www.ndteng.com
ndteng@olympusNDT.com