

# Excite Range

2011 Models Edition 1



Proud Sponsor of Home Nations Football



# Exciting times ahead.



## **Introducing the Special Edition Excite range.**

All your favourite Vauxhall models – New Corsa, New Astra, New Meriva and Zafira – with a lot more exciting features.

Enjoyable to drive and affordable to own, every Special Edition Excite model is packed with amazing features – like Bluetooth® connectivity, air conditioning and striking alloy wheel designs. And most models are available with our ultra-efficient ecoFLEX engines that save you money on your motoring too.



Please see back cover for more details.



## Contents:

- 04 New Corsa Excite
- 06 New Astra Excite
- 08 New Meriva Excite
- 10 Zafira Excite
- 12 Excite accessories
- 14 Excite colours and trims

## Specifications:

- 16 New Corsa Excite
- 18 New Astra Excite
- 20 New Meriva Excite
- 22 Zafira Excite

# New Corsa



# Excite

New Corsa Excite. With new styling inside and out. Smart new alloy wheels, an integrated Bluetooth® system, a CD player with MP3 format and Aux-in, there's more than enough to get excited about. Choose from 3-door or 5-door versions both with real agility. There's fuel-efficient petrol or diesel engines, manual or Easytronic transmissions and a selection of eye-catching exterior colours. What more could you ask for?



### Engine availability:

- 1.0i 12v ecoFLEX
- 1.2i 16v VVT
- 1.2i 16v VVT ecoFLEX Easytronic
- 1.4i 16v VVT
- 1.3CDTi 16v (75PS) ecoFLEX

### Standard features include:

- 16-inch alloy wheels (15-inch steel spare) **6**
- Mobile phone system with Bluetooth® (does not include phone or cradle) **2**
- Auxiliary-in socket\* **3**
- CD player with MP3 format/stereo radio (CD 30 MP3)
- Steering wheel mounted audio controls
- Front fog lights
- Air conditioning (non-air conditioned 1.0i 12v and 1.2i 16v models also available)
- Daytime running lights
- Steering column adjustable for reach and rake **4** and **5**
- Driver's seat height adjuster
- Remote control central deadlocking
- Electrically operated front windows
- Electrically adjustable/heated door mirrors
- Anti-lock Braking System (ABS)
- Punch Charcoal cloth trim **1**

\*MP3 player not included.





# New Astra



# Excite

Sleek, stylish and dynamic – the New Astra is all about excitement. With fantastic features including stunning new alloy wheels, integrated Bluetooth® facility, cruise control and air conditioning as standard – discover how it can make your life more exciting too.

New Astra Excite is available as a 5-door hatchback with space and comfort for five and excellent interior ergonomics. And with a choice of efficient, multi-valve petrol or diesel engines – it drives as dynamically as it looks.



### Engine availability:

- 1.4i 16v VVT (100PS)
- 1.6i 16v VVT
- 1.7CDTi 16v (110PS) ecoFLEX

### Standard features include:

- 17-inch alloy wheels (steel space saver spare) **5**
- Mobile phone system with Bluetooth® (does not include phone or cradle)
- Auxiliary-in socket
- CD player with MP3 format/stereo radio (CD 400)
- Steering wheel mounted audio controls
- Air conditioning **2**
- Daytime running lights **4**
- Steering column adjustable for reach and rake
- Cruise control **3**
- Ambient light in centre console and roof
- Electrically operated front windows
- Electronic Stability Programme-plus (ESP-plus)
- Anti-lock Braking System (ABS)
- Scene Jet black cloth trim **1**



# New Meriva Excite

Embrace life with New Meriva Excite. With flexible seating and smart storage, it also comes with great features – including an integrated Bluetooth® facility and USB connection with iPod™ control. Not to mention striking new alloy wheels, air conditioning and a choice of efficient petrol or diesel engines.

With clever new doors which are rear-hinged and open the other way, it's easier for everyone to get in and out. And simpler to ensure the kids are seated safe and secure. Welcome to clever family motoring!







1



2



3



4



### Engine availability:

- 1.4i 16v VVT (100PS)
- 1.4i 16v VVT Turbo (120PS)
- 1.3CDTi 16v (75PS)

### Standard features include:

- 16-inch alloy wheels (emergency tyre inflation kit in lieu of spare wheel)
- Mobile phone system with Bluetooth® (does not include phone or cradle)
- USB connection with iPod™ control
- Auxiliary-in socket
- CD player with MP3 format/stereo radio (CD 400) [2]
- Steering wheel mounted audio controls
- Daytime running lights [4]
- Front fog lights
- Air conditioning
- Cruise control [3]
- FlexDoors®
- FlexSpace® rear seating
- Steering column adjustable for reach and rake
- Four airbags
- Electronic Stability Programme-plus (ESP-plus)
- Anti-lock Braking System (ABS)
- Pepe Jet Black cloth trim [1]



5

# Zafira

With sharp styling and a high quality interior, Zafira Excite doesn't disappoint. Add to this, great features – like attractive new alloy wheels, CD player with MP3 format and an integrated Bluetooth® facility, trip computer and air conditioning – it's clear to see Zafira Excite has definitely got the X-factor.

# Excite



Zafira Excite delivers truly impressive driving dynamics and the ability to carry up to seven people in real comfort with Flex7® seating versatility. There's also the choice of multi-valve petrol or diesel engine efficiency. So, if there's another word for flexibility, it must be Zafira.

*Front and rear parking distance sensors are optional at extra cost.*



1



2



3



4

## Standard features include:

- 16-inch alloy wheels (emergency tyre inflation kit in lieu of spare wheel) [5]
- Mobile phone system with Bluetooth® (does not include phone or cradle) [2]
- Auxiliary-in socket
- CD player with MP3 format/stereo radio (CD 30 MP3)
- Steering wheel mounted audio controls [4]
- Air conditioning [3]
- Flex7® seating system
- Front fog lights
- Leather-covered steering wheel
- Steering column adjustable for reach and rake
- Multi-function trip computer
- Body-colour electrically adjustable/heated door mirrors
- Dark-tinted glass (excludes windscreen and front door windows)
- Alloy-effect roof rails
- Electronic Stability Programme-plus (ESP-plus)
- Anti-lock Braking System (ABS)
- Twist Charcoal cloth trim [1]

## Engine availability:

- 1.6i 16v VVT
- 1.8i 16v VVT
- 1.7CDTi 16v (110PS) ecoFLEX



5

# Excite Accessories

Vauxhall genuine accessories are the right choice for your Excite model. You'll find lots of accessories that will help you derive even more excitement from your Vauxhall.

Whatever you're into, there's certain to be an accessory with your name on it. We've only featured a small selection of what's available here. For more details, refer to the Vauxhall Car Accessory Brochure and Car and Accessory Price Guide or check out our website at:

[www.vauxhall.co.uk/accessories](http://www.vauxhall.co.uk/accessories)







VXR styling products allow you to connect with the performance and excitement at the heart of the VXR brand. Taking the same ethos as our brief we have created a definitive line-up of VXR styling products that will add a degree of individuality to any new Excite model.



**VXR Styling Pack.** This pack is available on all Excite models as separate accessories fitted by your Vauxhall retailer.

Styling products include:  
 Front lower spoiler  
 Rear lower skirt  
 Rear roof spoiler **[1]**  
 Side sills

**Base carrier and roof box.** **[2]** The Vauxhall roof rack system begins with a lockable base carrier system, comprising two T-track roof bars which support a wide range of attachments designed by Thule. These include bicycle carriers, ski carriers and a range of roof boxes that are all lockable and easy-to-fit (available separately).



**Child seats.** **[3]** The rear facing Baby-Safe (up to 13kg) and KID (15-36kg) seats are fixed with a standard lap and diagonal seatbelt. The DUO ISOFIX (9-18kg) can also be attached using the ISOFIX child seat restraint fittings (complete with top tether on most models) standard on the outer rear seats of all new Excite models in the range.



**Semi-rigid cargo liner.** **[4]** Protect the load area with a semi-rigid moulded plastic liner. Designed with lipped sides specifically for each model in the Excite range it provides maximum protection yet is easily removed for cleaning.

**Privacy shades.** **[6]** Available for the rear side windows and tailgate glass of all the Excite models in the range, they provide shade from the sun when required, yet still allow the window to be lowered with the shades in place.



**Rear parking distance sensors.** **[5]** Activated automatically as you select reverse, this clever system beeps faster the closer you get to an obstruction, changing to a continuous tone at 30cm away.

**Floor mats.** **[7]** A range of floor mats are available for each Excite model and have unique fixing points to keep them firmly in place.



# Excite Colours & trims

Vauxhall Excite models are available in a great choice of exciting exterior colours, with cloth trims carefully chosen to complement the colour you choose. Your local Vauxhall retailer has a comprehensive showroom display of all our paint samples and trim swatches.



**Flame Red – Solid**



**Power Red – Solid (two-coat)**



**Glacier White – Solid**



**Olympic White – Solid**



**Royal Blue – Solid**



**Guacamole – Solid**



**Sunny Melon – Solid**



**Star Silver – Metallic\***



**Sovereign Silver – Metallic\***



**Silver Lightning – Metallic\***



**Metro Blue – Metallic\***



**Chilli Orange – Metallic\***



**Pepperdust – Metallic\***



**Technical Grey – Metallic\***



**Silver Lake – Metallic\***



**Oriental Blue – Pearlescent\***



**Black Sapphire – Pearlescent\***



**Waterworld – Pearlescent\***



**Ultra Blue – Pearlescent\***



**Lime Green – Pearlescent\***

*\*Optional at extra cost.*

*Due to the limitations of the printing process, the colours reproduced may vary slightly from the actual paint colour or trim material. As a result, they should be used as a guide only. Your Vauxhall retailer has a comprehensive display of our paint samples.*

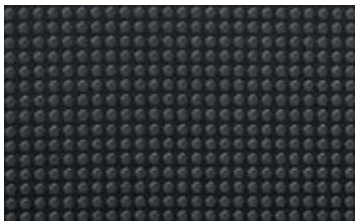

**Punch – Charcoal**

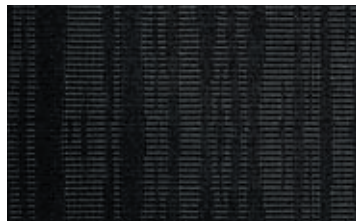

**Scene – Jet Black**

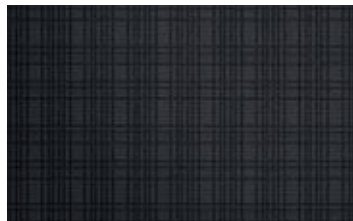

**Pepe – Jet Black**

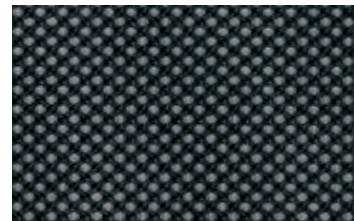

**Twist – Charcoal**

**Model, trim name and colours**

	New Corsa Excite Punch – Charcoal	New Astra Excite Scene – Jet Black	New Meriva Excite Pepe – Jet Black	Zafira Excite Twist – Charcoal
<b>Solid</b>				
Flame Red	•		•	
Power Red (two-coat)		•		•
Glacier White	•		•	
Olympic White		•		•
Royal Blue			•	
Guacamole	•			
Sunny Melon	•			
<b>Two-coat metallic (optional at extra cost)</b>				
Star Silver	•		•	
Sovereign Silver		•		•
Silver Lightning				•
Metro Blue				•
Chilli Orange	•		•	
Pepperdust	•		•	
Technical Grey	•	•	•	
Silver Lake	•	•	•	
<b>Two-coat pearlescent (optional at extra cost)</b>				
Oriental Blue	•		•	
Black Sapphire	•	•	•	•
Waterworld	•	•	•	•
Ultra Blue				•
Lime Green	•			



Front passenger's underseat storage tray.



Driver's seat height adjuster.



Cruise control (optional). Part of Technical Pack.



Easytronic transmission (optional).

## Equipment highlights

- 16-inch alloy wheels with 195/55 R 16 low profile tyres (15-inch steel spare)
- Mobile phone system with Bluetooth® (does not include phone or cradle)
- Auxiliary-in socket\*
- CD player with MP3 format/stereo radio (CD 30 MP3)
- Graphic information display
- Steering wheel mounted audio controls
- Front fog lights
- Air conditioning (non-air conditioned 1.0i 12v and 1.2i 16v models also available)
- Driver's and front passenger's dual-stage airbags
- Steering column adjustable for reach and rake
- Driver's seat height adjuster
- Remote control central deadlocking
- Electrically operated front windows
- Electrically adjustable/heated door mirrors
- Anti-lock Braking System (ABS)

\* = When using an MP3 player in the car the majority of the controls, such as track selection, remain solely on the player, while only the volume is controlled via the car's regular audio controls.

## Safety and security

- Deactivation switch for front passenger's airbag
- ISOFIX child seat restraint system for outer rear seats incorporating top tether (does not include child seat)
- Front seatbelt buckle pretensioners
- Front seatbelt force limiters
- Electronic engine deadlock immobiliser
- Door-to-door illumination
- Welcome lighting
- Daytime running lights
- Folding key

## Practicality and convenience

- Speed-sensitive power-assisted steering
- Intermittent rear window wash/wipe
- Front passenger's underseat storage tray
- Map pockets in front seat back
- One-piece folding rear seat
- Stowage facility for luggage compartment cover behind rear seats
- Digital clock with automatic RDS time adjustment
- Lights-on audible warning

## Comfort and style

- Matt chrome-effect centre console and steering wheel inlays
- Chrome-effect interior door handles and handbrake button
- Interior pollen filter
- Body-colour bumpers, door handles and tailgate handle
- Tinted glass

## Insurance groups (ABI)

1.0i 12v ecoFLEX	3E
1.2i 16v VVT	7E
1.2i 16v VVT ecoFLEX Easytronic	7E
1.4i 16v VVT	9E
1.3CDTi 16v (75PS) ecoFLEX	6E

**Please note:** Insurance groups relate to the 50 group rating.

## Colour and trim availability

See pages 14 and 15 for details.

## Fuel tank capacity

- 45 litres (9.9 gallons)

## Options at extra cost

- Protection Pack – comprising front seat side-impact airbags/full-size curtain airbags/pyrotechnic front lap belt pretensioner system
- Technical Pack – comprising cruise control/multi-function trip computer
- Electronic Stability Programme-plus (ESP-plus)
- ISOFIX child seat restraint system for front passenger's seat (does not include child seat)
- Height-adjustable centre rear seat head restraint (five-door models only)
- Electronic Climate Control (ECC) (only available on air-conditioned models, not available with Touch and Connect)
- Electrically operated sliding glass sunroof with interior blind (non-metallic roof panel is coloured black, deletes front passenger's underseat storage tray)
- Dark-tinted windows (excludes windscreen and front door windows)
- Touch and Connect multi-media – touch-screen satellite navigation/mobile phone system with Bluetooth®/USB connection with iPod™ control/auxiliary-in socket/CD player with MP3 format/stereo radio/triple information display (not available in conjunction with ECC)

**Please note:** Additional standard features applicable to the New Corsa Range can be found in the New Corsa 2011 main brochure.



## Exterior dimensions millimetres (inches)

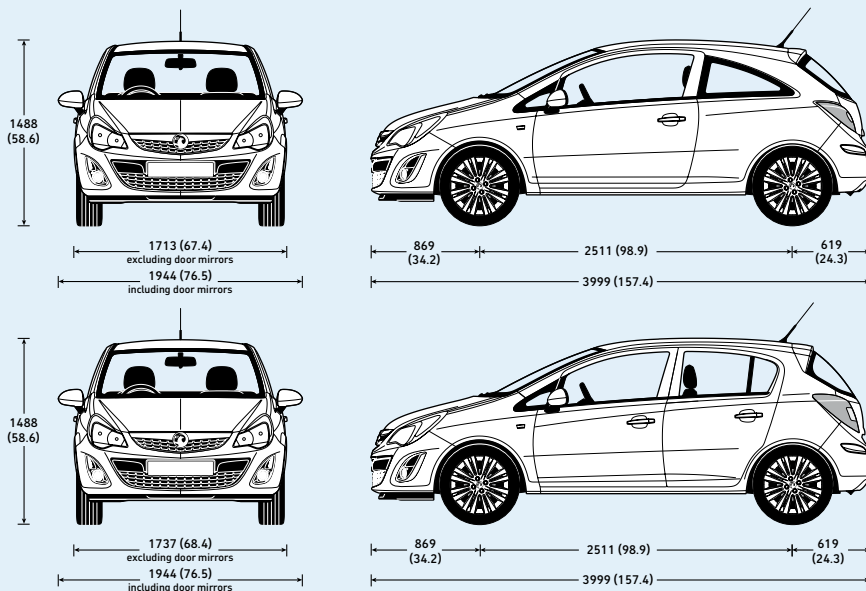

## Maximum luggage capacity\*\*

With rear seats up – under luggage compartment cover:

- 3-door – 285 litres (10.0 cu.ft.)
- 5-door – 285 litres (10.0 cu.ft.)

With rear seats folded – to roof:

- 3-door – 1050 litres (37.1 cu.ft.)
- 5-door – 1100 litres (38.8 cu.ft.)

\*\* = Measured using the ECIE method.

## Engines

### 1.0i 12v Twinport ecoFLEX petrol (998cc).

Max. power: 65PS (48kW) @ 5300rpm.

Max. torque: 90Nm (66 lb.ft.) @ 4000rpm.

### 1.2i 16v VVT ECOTEC-4 petrol (1229cc).

Max. power: 85PS (63kW) @ 5600rpm.

Max. torque: 115Nm (85 lb.ft.) @ 4000rpm.

### 1.4i 16v VVT ECOTEC-4 petrol (1398cc).

Max. power: 100PS (74kW) @ 6000rpm.

Max. torque: 130Nm (96 lb.ft.) @ 4000rpm.

### 1.3CDTi 16v (75PS) ecoFLEX turbo diesel (1248cc).

Max. power: 75PS (55kW) @ 4000rpm.

Max. torque: 190Nm (140 lb.ft.) @

1750-2250rpm.

## Performance, fuel economy and emissions

	Performance†		Fuel economy mpg (litres/100km)			CO <sub>2</sub> emissions (g/km)
	Maximum speed (mph)	Acceleration 0-62mph (secs)	Urban driving	Extra-urban driving	Combined figure	
1.0i 12v ecoFLEX	96	18.2	44.8 (6.3)	67.3 (4.2)	56.5 (5.0)	117
1.2i 16v VVT	107	13.6	40.9 (6.9)	64.2 (4.4)	53.3 (5.3)	124
1.2i 16v VVTecoFLEX Easytronic	107	14.9	43.5 (6.5)	67.3 (4.2)	55.4 (5.1)	119
1.4i 16v VVT††	112	11.9	39.8 (7.1)	61.4 (4.6)	51.4 (5.5)	129
1.4i 16v VVT††	112	11.9	38.7 (7.3)	58.9 (4.8)	49.6 (5.7)	134
1.3CDTi 16v (75PS) ecoFLEX 3-door	101	14.9	53.3 (5.3)	80.7 (3.5)	67.3 (4.2)	110
1.3CDTi 16v (75PS) ecoFLEX 5-door	101	14.9	53.3 (5.3)	78.5 (3.6)	67.3 (4.2)	112

Fuel consumption and CO<sub>2</sub> emission data complies with the relevant EU regulations. **Important:** the results given relate to the particular vehicle tested; inevitably there are differences between individual vehicles of the same model. Driving style, road and traffic conditions, vehicle mileage and standard of maintenance may also affect fuel consumption.

† = Manufacturer's figures. †† = Please consult your Retailer for availability and clarification regarding the differences between fuel economy and CO<sub>2</sub> emissions for 1.4i 16v VVT models.



Satellite navigation (optional).



Auxiliary-in socket (standard).  
USB connection (optional).



Cruise control.



Dual-zone Electronic Climate Control (ECC) (optional).

## Equipment highlights

- 17-inch alloy wheels with 215/50 R 17 (petrol models), 225/50 R 17 (diesel models) ultra-low profile tyres (space-saver spare)
- Mobile phone system with Bluetooth® (does not include phone)
- Auxiliary-in socket\*
- CD player with MP3 format/stereo radio (CD 400)
- Steering wheel mounted audio controls
- Air conditioning
- Chrome-bezelled steering wheel
- Cruise control
- Ambient light in centre console and roof
- 12-volt auxiliary power socket within front centre console
- Anti-lock Braking System (ABS)

\* = When using an MP3 player in the car the majority of the controls, such as track selection, remain solely on the player, while only the volume is controlled via the car's regular audio controls.

## Safety and security

- Driver's and front passenger's airbags
- Front seat side-impact airbags
- Full-size curtain airbags
- Remote control central deadlocking
- Daytime running lights
- Electronic engine deadlock immobiliser
- Three lap and diagonal rear seatbelts
- Electronic Stability Programme-plus (ESP-plus)

## Practicality and convenience

- Steering column adjustable for reach and rake
- Power-assisted steering
- 60/40 split-folding rear seat back
- Electrically operated front windows
- Intermittent rear window wash/wipe
- Lights-on audible warning
- Front map reading lights integral with courtesy light

## Comfort and style

- Silver dust-effect centre console and door inserts
- Chrome-effect interior door handles
- Black instruments with chrome edging
- Driver's seat height adjuster
- Body-colour bumpers
- Body-colour door handles
- Body-colour electrically adjustable/heated door mirrors
- Tinted glass

## Insurance groups (ABI)

1.4i 16v VVT	9E
1.6i 16v VVT	12E
1.7CDTi 16v (110PS) ecoFLEX	13E

**Please note:** Insurance groups relate to 50 group rating.

## Colour and trim availability

See pages 14 and 15 for details.

## Fuel tank capacity

- 56 litres (12.3 gallons)

## Options at extra cost

- VXR Styling Pack\*\* – comprising body-colour front lower/side sills/rear lower skirt/roof spoiler
- Interior Versatility Pack – comprising fold-down rear seat centre armrest with drinks holders and load-through facility/front passenger's underseat storage facility/height-adjustable centre rear seat head restraint
- Towing Pack – comprising detachable tow bar/trailer stability programme
- Dual-zone Electronic Climate Control (ECC)
- Flex Floor luggage compartment
- Electrically foldable door mirrors
- Remote control ultrasonic security alarm
- Tyre pressure monitoring system
- Front and rear parking distance sensors
- Ergonomic sports front seats†
- Satellite navigation/CD player with MP3 format/stereo radio (CD 500)
- USB connection with iPod™ control
- Digital Audio Broadcast (DAB) stereo receiver
- Embedded mobile phone system with Bluetooth® (does not include phone)

\*\* = Not available on 1.4i 16v VVT models.

† = Changes seat trim to Lace Cloth.

## Exterior dimensions millimetres (inches)

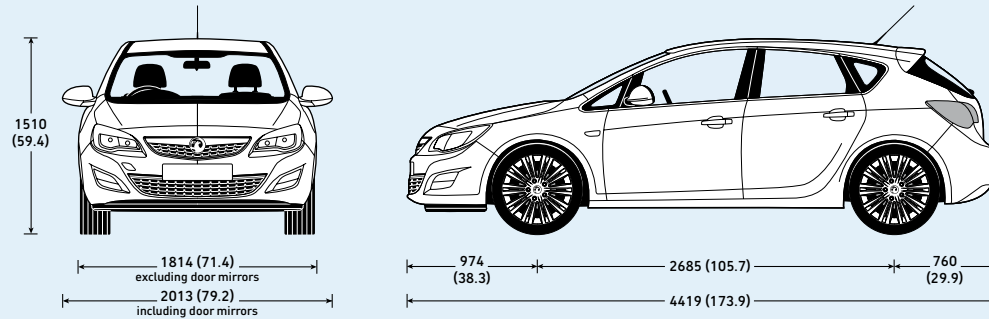

## Maximum luggage capacity\*

With rear seats up\*\*:

- 351 litres (12.3 cu.ft.)

With rear seats down†:

- 776 litres (27.4 cu.ft.)

\* = Measured using the ECIE method.

\*\* = Flex Floor in lowest position.

† = To upper edge of front seat.

## Engines

### 1.4i 16v VVT ECOTEC-4 petrol (1398cc).

Emission compliance: Euro 5

Max. power: 100PS (74kW) @ 6000rpm.

Max. torque: 130Nm (96 lb.ft.) @ 4000rpm.

### 1.6i 16v VVT ECOTEC-4 petrol (1598cc).

Emission compliance: Euro 5

Max. power: 115PS (85kW) @ 6000rpm.

Max. torque: 155Nm (114 lb.ft.) @ 4000rpm.

### 1.7CDTi 16v (110PS) ECOTEC-4

**Turbo diesel with DPF** (1686cc).

Emission compliance: Euro 5

Max. power: 110PS (81kW) @ 3800rpm.

Max. torque: 260Nm (192 lb.ft.) @

1700-2500rpm.

## Performance, fuel economy and emissions

	Performance‡		Fuel economy mpg (litres/100km)			CO <sub>2</sub> emissions (g/km)
	Maximum speed (mph)	Acceleration 0-60mph (secs)	Urban driving	Extra-urban driving	Combined figure	
1.4i 16v VVT	111	12.9	39.8 (7.1)	61.4 (4.6)	51.4 (5.5)	129
1.6i 16v VVT	118	10.9	34.0 (8.3)	55.4 (5.1)	44.8 (6.3)	147
1.7CDTi 16v (110PS) ecoFLEX	113	11.8	51.4 (5.5)	72.4 (3.9)	62.8 (4.5)	119

Fuel consumption and CO<sub>2</sub> emission data complies with the relevant EU regulations. **Important:** the results given relate to the particular vehicle tested; inevitably there are differences between individual vehicles of the same model. Driving style, road and traffic conditions, vehicle mileage and standard of maintenance may also affect fuel consumption.

‡ = Manufacturer's figures.



Satellite navigation (optional).



Chrome-effect interior door handles.



Cruise control.



Electric parking brake.

## Equipment highlights

- 16-inch alloy wheels with 205/55 R 16 ultra-low profile tyres (emergency tyre inflation kit in lieu of spare wheel)
- Mobile phone system with Bluetooth® (does not include phone)
- USB connection with iPod™ control
- Auxiliary-in socket\*
- CD player with MP3 format/stereo radio (CD 400)
- Steering wheel mounted audio controls
- Front fog lights
- Air conditioning
- Cruise control
- FlexDoors®
- FlexSpace® rear seating
- Steering column adjustable for reach and rake
- Electronic Stability Programme-plus (ESP-plus)
- Anti-lock Braking System (ABS)

\* = When using an MP3 player in the car the majority of the controls, such as track selection, remain solely on the player, while only the volume is controlled via the car's regular audio controls.

## Safety and security

- Driver's and front passenger's airbags
- Front seat side-impact airbags
- ISOFIX child seat restraint system for outer rear seats (does not include child seat)
- Three lap and diagonal rear seatbelts
- Remote control central deadlocking
- Welcome lighting
- Door-to-door illumination
- Daytime running lights
- Electric parking brake

## Practicality and convenience

- 40/20/40 split-folding rear seat
- Sliding outer rear seats with ability to slide forwards, backwards and diagonally inwards
- Twin electrically adjustable/heated door mirrors
- Electrically operated front windows
- Graphic information display

## Comfort and style

- Chrome-effect detailing on instrument surrounds
- Driver's seat height adjuster
- Body-colour bumpers and door handles
- Chrome-effect moulding on tailgate
- Chrome-effect interior door handles

## Insurance groups (ABI)

1.4i 16v VVT (100PS)	8E
1.4i 16v VVT Turbo (120PS)	12E
1.3CDTi 16v (75PS)	6E

Please note: Insurance groups relate to the 50 group rating.

## Colour and trim availability

See pages 14 and 15 for details.

## Fuel tank capacity

- 54 litres (11.9 gallons)

## Options at extra cost

- Protection Pack – comprising full-size curtain airbags/active-safety front seat head restraints/seatbelt unfastened warning light for rear seats
- Height-adjustable centre rear seat head restraint
- Front passenger's seat height adjuster
- 16-inch steel space-saver spare wheel/tyre (in lieu of emergency tyre inflation kit)
- Front and rear parking distance sensors
- Satellite navigation/CD player with MP3 format/stereo radio/USB connection with iPod™ control/auxiliary-in socket (CD 500)
- Stereo radio with Digital Audio Broadcast



## Exterior dimensions millimetres (inches)

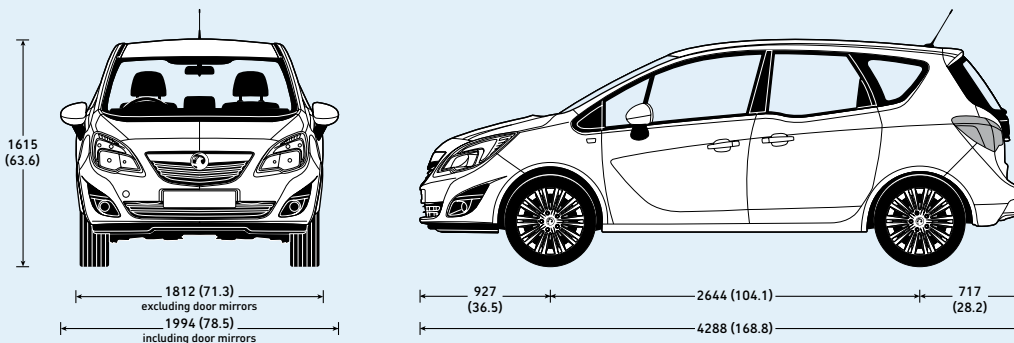

## Maximum luggage capacity\*

With rear seats up – to upper edge of rear seat back:

- 397 litres (14.0 cu.ft.)

With rear seats folded flat – to upper edge of front seat back:

- 916 litres (32.3 cu.ft.)

With rear seats folded flat – to roof:

- 1496 litres (52.8 cu.ft.)

\* = Measured using the ECIE method.

## Maximum loadspace dimensions

millimetres (inches)

Load floor length (behind front seat)	1642 (64.6)
Load area width	1052 (41.4)
Load area height	803 (31.6)
Tailgate aperture width	1086 (42.8)
Tailgate aperture height	791 (31.1)

## Engines

**1.4i 16v VVT ECOTEC-4 petrol** (1398cc).

Max. power: 100PS (74kW) @ 6000rpm.

Max. torque: 130Nm (96 lb.ft.) @ 4000rpm.

**1.4i 16v VVT Turbo petrol** (1364cc).

Max. power: 120PS (88kW) @

4800-6000rpm.

Max. torque: 175Nm (129 lb.ft.) @

1750-4800rpm.

**1.3CDTi 16v ECOTEC-4 diesel** (1248cc).

Max. power: 75PS (55kW) @ 4000rpm.

Max. torque: 180Nm (133 lb.ft.) @

1750-2500rpm.

## Performance, fuel economy and emissions

	Performance**		Fuel economy mpg (litres/100km)			CO <sub>2</sub> emissions (g/km)
	Maximum speed (mph)	Acceleration 0-62mph (secs)	Urban driving	Extra-urban driving	Combined figure	
1.4i 16v VVT (100PS)	110	13.9	35.8 (7.9)	55.4 (5.1)	46.3 (6.1)	144
1.4i 16v VVT Turbo (120PS)	117	11.5	35.3 (8.0)	56.5 (5.0)	46.3 (6.1)	143
1.3CDTi 16v (75PS)	99	16.9	47.9 (5.9)	65.7 (4.3)	57.6 (4.9)	129

Fuel consumption and CO<sub>2</sub> emission data complies with the relevant EU regulations. **Important:** the results given relate to the particular vehicle tested; inevitably there are differences between individual vehicles of the same model. Driving style, road and traffic conditions, vehicle mileage and standard of maintenance may also affect fuel consumption.

\*\* = Manufacturer's figures.



Steering wheel mounted audio controls.



Driver's and front passenger's front and side-impact airbags.



Rear seat Twin Audio® system (optional).



Remote control security alarm (optional).

## Equipment highlights

- 16-inch alloy wheels with 205/55 R 16 ultra-low profile tyres (emergency tyre inflation kit in lieu of spare wheel)
- Mobile phone system with Bluetooth® (does not include phone or phone-specific cradle)
- Auxiliary-in socket\*
- CD player with MP3 format/stereo radio (CD 30 MP3)
- Steering wheel mounted audio controls
- Air conditioning
- Front fog lights
- Leather-covered steering wheel
- Multi-function trip computer
- Body-colour electrically adjustable/heated door mirrors
- Dark-tinted glass (excludes windscreen and front door windows)
- Electronic Stability Programme-plus (ESP-plus)
- Anti-lock Braking System (ABS)

\* = When using an MP3 player in the car the majority of the controls, such as track selection, remain solely on the player, while only the volume is controlled via the car's regular audio controls.

## Safety and security

- Euro NCAP five-star (adult occupant rating)
- Driver's and front passenger's front and side-impact airbags
- Full-size front and second-row curtain airbags
- Front seatbelt force limiters
- Lap and diagonal inertia-reel seatbelts on all seats
- ISOFIX child seat restraint system for outer second-row seats (does not include child seat)
- Remote control central deadlocking
- Electronic engine deadlock immobiliser

## Practicality and convenience

- Flex7 seating
- 40/20/40 split-folding second-row seat back
- Second-row seats with sliding function plus fold and stow facility
- Two individual fold-flat third-row seats
- Steering column adjustable for reach and rake
- Alloy-effect roof rails

## Comfort and style

- Piano black-effect centre console
- Matt chrome-effect inserts on facia and doors
- Chrome-effect interior door handles
- Driver's seat height adjuster
- Second-row passenger compartment heating outlets
- Black instrument dials
- Body-colour door and tailgate handles, bumpers and side-protection mouldings

## Insurance groups (ABI)

1.6i 16v VVT	13E
1.8i 16v VVT	17E
1.7CDTi 16v (110PS) ecoFLEX	15E

**Please note:** Insurance groups relate to 50 group rating.

## Colour and trim availability

See pages 14 and 15 for details.

## Fuel tank capacity

- 58 litres (12.8 gallons)

## Options at extra cost

- FlexOrganiser® Pack – comprising 3D storage net/side net pocket/four side rail hooks/four side rails
- Electronic Climate Control (ECC)
- Full-size steel spare wheel (in lieu of emergency tyre inflation kit)
- Vertical load-restraining net
- Cruise control
- Front and rear parking distance sensors
- Keyless entry and start
- Remote control ultrasonic security alarm
- Six-disc CD autochanger with MP3 format/stereo radio with Digital Audio Broadcast (CDC 40 DAB)
- Rear seat Twin Audio® system (deletes auxiliary-in socket)

## Exterior dimensions millimetres (inches)

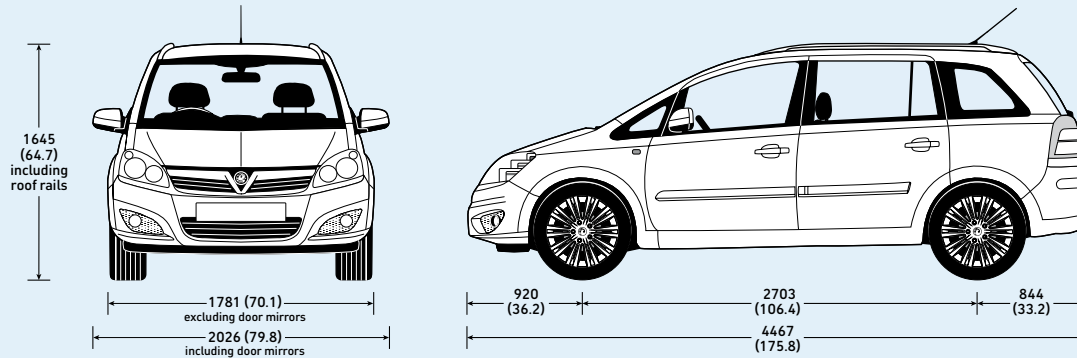

## Engines

### 1.6i 16v VVT ECOTEC-4 petrol (1598cc).

Emission compliance: Euro 5  
 Max. power: 115PS (85kW) @ 6000rpm.  
 Max. torque: 155Nm (114 lb.ft.) @ 4000rpm.

### 1.8i 16v VVT ECOTEC-4 petrol (1796cc).

Emission compliance: Euro 5  
 Max. power: 140PS (103kW) @ 6300rpm.  
 Max. torque: 175Nm (129 lb.ft.) @ 3800rpm.

### 1.7CDTi 16v ecoFLEX diesel (1686cc).

Emission compliance: Euro 5  
 Max. power: 110PS (81kW) @ 3800rpm.  
 Max. torque: 260Nm (192 lb.ft.) @ 2300rpm.

## Performance, fuel economy and emissions

	Performance <sup>††</sup>		Fuel economy mpg (litres/100km)			
	Maximum speed (mph)	Acceleration 0-60mph (secs)	Urban driving	Extra-urban driving	Combined figure	CO <sub>2</sub> emissions (g/km)
1.6i 16v VVT	115	12.5	32.5 (8.7)	51.4 (5.5)	42.2 (6.7)	157
1.8i 16v VVT	122	10.8	29.4 (9.6)	49.6 (5.7)	39.2 (7.2)	168
1.7CDTi 16v (110PS) ecoFLEX	111	12.5	46.3 (6.1)	62.8 (4.5)	55.4 (5.1)	134

Fuel consumption and CO<sub>2</sub> emission data complies with the relevant EU regulations. **Important:** the results given relate to the particular vehicle tested; inevitably there are differences between individual vehicles of the same model. Driving style, road and traffic conditions, vehicle mileage and standard of maintenance may also affect fuel consumption.

†† = Manufacturer's figures.

## Maximum luggage capacity\*\*

Behind second-row seats – to glass line:

- 645 litres (22.8 cu.ft.)

With rear seats folded flat – to roof:

- 1820 litres (64.3 cu.ft.)

\*\* = Measured using the ECIE method.

## Loadspace dimensions

millimetres (inches)

Maximum load floor length (behind front seats <sup>†</sup> )	1809 (71.2)
Maximum load floor length (behind second-row seat)	1088 (42.8)
Maximum load floor length (behind third-row seat)	405 (15.9)
Maximum load floor width	1114 (43.9)
Width between wheel arches	1071 (42.2)
Tailgate aperture height	893 (35.2)
Tailgate aperture width	1136 (44.7)

† = Second-row seat back lowered.

# Trust Vauxhall

## Protecting the environment

Vauxhall's commitment to the environment is demonstrated by our products' many environmental awards, won both through the use of more recycled materials and by becoming cleaner and more efficient. For information on Vauxhall's efforts to achieve an environmentally sustainable future, see [www.vauxhall.co.uk/recycling](http://www.vauxhall.co.uk/recycling)

## Fleet Customer Services

Our dedicated support services for fleet managers includes factory demonstrators, a three-day test drive programme and information on whole life costs, company car taxation and finance. For further information please call **0870 010 0651**.



When you have finished with this brochure please recycle it

## Buying your car

GMAC offers one of the most comprehensive and competitive ranges of financing plans in the UK. Contact your local Vauxhall retailer for details or call the GMAC customer service centre on **0845 712 3444**.

## Servicing and maintenance

The best way to maximise the performance and reliability of your Vauxhall is to have all routine servicing and maintenance carried out at one of around 400 Vauxhall retailers. To find your nearest retailer call **0845 600 1500**.

## In the event of an accident...

Vauxhall Accident Support helps keep you mobile following an accident. Benefits include scene-of-accident advice, message service, assistance with claims and vehicle recovery. For further details call **0800 010 304**.

## Vauxhall Insurance

Available for new and used Vauxhalls, a Vauxhall Insurance policy offers a unique package designed specifically for Vauxhall drivers. For a highly competitive quotation, call **0844 84 85 840** (Great Britain) or **0845 35 13 410** (N. Ireland). Or just visit our website at [www.vauxhall.co.uk](http://www.vauxhall.co.uk)

## For more information...

For a brochure on any Vauxhall model (up to a maximum of three per caller) or location of your nearest Vauxhall retailer please **Lo-call 0845 600 1500**.

Alternatively, details can be found on our website at [www.vauxhall.co.uk](http://www.vauxhall.co.uk)

Proud Sponsor of Home Nations Football



## Vauxhall Lifetime Warranty



We're so confident in Vauxhall quality and reliability

that we are now able to offer a warranty that could last a lifetime. Available to the first owner of all new Vauxhall passenger cars, it's valid for the lifetime of the vehicle up to a maximum of 100,000 miles\*. In addition, our warranty also includes Vauxhall Assistance for 12 months from first registration and six years body panel anti-perforation warranty. Full details of Vauxhall's warranties including terms, conditions and exclusions can be obtained through any authorised Vauxhall Retailer or go to [www.vauxhall.co.uk/warranty](http://www.vauxhall.co.uk/warranty)

## VM1009151 Excite Range 2011 Models Edition 1

**Please note:** Glacier White, Olympic White, Sunny Melon and Guacamole exterior Brilliant paint colours are all optional at extra cost.

04/11

\*Vauxhall Lifetime Warranty covers lifetime ownership of first car owner; 100,000 mile limit, annual check required. The warranty excludes wear and tear and serviceable items and the vehicle must be serviced in accordance with the manufacturer's servicing schedule to continue the lifetime warranty. Terms and conditions apply. Offer available to all Vauxhall passenger cars (this offer does not apply to car-derived vans) from 1st August 2010.

Every effort has been made to ensure that the contents of this publication were accurate and up-to-date at the time of going to press (February 2011). Vauxhall vehicles are equipped with components manufactured by various General Motors operating units and outside suppliers. The Company reserves the right to alter specifications and withdraw products from sale without notice. Any such alterations will be notified to Vauxhall retailers at the earliest opportunity; please consult your local retailer for the latest information. The specifications detailed within this Special Edition brochure are not necessarily applicable to alternative New Corsa, New Astra, New Meriva and Zafira models. Details of any such models will be contained in specific literature or found on the Vauxhall website. Please note that Vauxhall retailers are not the agents of General Motors UK Limited and are not authorised to bind the Company by any specific or implied undertaking or representation. It is advisable to ensure that your motor insurance policy provides adequate cover for additional fitted options and accessories. As part of Vauxhall's policy of environmental care, this brochure is printed on paper manufactured using Elemental Chlorine Free pulps from specially farmed, sustainable timber resources. All rights reserved. No part of this publication may be reproduced in any form or by any means, without the prior written permission of General Motors UK Limited.



**VAUXHALL**