



Want to save up to £2000\* on a new Vauxhall?



Apply for The GM Platinum Card today

- ❖ 100 Rebate Points when you use your GM Card for the first time - worth £100 off a new Vauxhall
- ❖ 3% of the value of your GM Card purchases as Rebate Points
- ❖ 0% p. a. on purchases and balance transfers fixed for the first five months from account opening. A 2% balance transfer fee applies (minimum £5)
- ❖ Typical **14.9% APR** variable

Call **0845 746 2777** and quote **REF:AGM1** or apply online at **www.gmcard.co.uk/brochure**

The GM Platinum Card is issued by HFC Bank Limited and is available to persons aged 18 years or over and resident in the UK (or 21 and over in the Channel Islands) and is subject to status and conditions. Written quotations are available upon request from The GM Platinum Card, PO Box 3615, Birmingham B3 2RJ. The typical APR quoted is the rate for new customers. \*Rebate Points are earned on purchases using The GM Platinum Card. Rebate Points are not earned on Balance Transfers or Cash Advances. You earn money off a new Vauxhall/Saab by accumulating Rebate Points under the Rebate Points Programme. Vauxhall Motors Ltd is solely responsible for the operation of the Rebate Points Programme, which is subject to the Rebate Points Programme Rules. You can redeem up to 2500 Rebate Points subject to the Model Line Maximum which will vary in amount in relation to different Vauxhall/Saab vehicle model lines and unlimited Partner Points. Rebate Points and unlimited Partner Points are redeemable as discounts on a new Vauxhall/Saab vehicle and must be redeemed four years from the issue date. Rebate Points may not be redeemed by Motability Contract Hire customers. The GM Card is a trading name and style of both HFC Bank Limited and Vauxhall Motors Ltd. HFC Bank registered in England No. 1117305. Registered Office: North Street, Winkfield, Windsor, Berkshire SL4 4TD is authorised and regulated by the Financial Services Authority. Member HSBC Group. HFC Bank Limited is not a member of the same group of companies as Vauxhall Motors Ltd, Saab GB Limited or GMAC. Vauxhall Motors Ltd, Registered Office: Griffin House, Osborne Road, Luton, Bedfordshire LU1 3YT. Registered in England number 135767.

You could  
dodge high  
premiums.



Call now to get a quote.

**0870 024 0240**

Lines open 8am-8pm Monday to Friday, 9am-5pm Saturday. Calls may be recorded.

**www.vauxhall.co.uk/insurance**

Vauxhall Motor Insurance is underwritten by UK Insurance Limited. Conditions apply. Calls may be recorded.



Every effort has been made to ensure that the contents of this publication were accurate and up-to-date at the time of going to press (August 2006). Vauxhall vehicles are equipped with components manufactured by various General Motors operating units and outside suppliers. The Company reserves the right to alter specifications and withdraw products from sale without notice. Any such alterations will be notified to Vauxhall retailers at the earliest opportunity; please consult your local retailer for the latest information. The specifications detailed within this brochure are not necessarily applicable to alternative models such as Special Editions. Details of any such models will be contained in specific literature or found on the Vauxhall website. Please note that Vauxhall retailers are not the agents of Vauxhall Motors Limited and are not authorised to bind the Company by any specific or implied undertaking or representation. It is advisable to ensure that your motor insurance policy provides adequate cover for additional fitted options and accessories. As part of Vauxhall's policy of environmental care, this brochure is printed on paper manufactured using Elemental Chlorine Free pulps from specially farmed, sustainable timber resources. All rights reserved. No part of this publication may be reproduced in any form or by any means, without the prior written permission of Vauxhall Motors Limited.

Published August 2006 (Graymatter) Vauxhall Motors Limited, Luton LU1 3YT www.vauxhall.co.uk

VM0606436



## New Vectra New Signum Specifications



Contents	
Equipment	S.2-S.8
Audio, Communication and Navigation	S.9
Technical data	S.10-S.17
Vauxhall by Design	S.18
Customer care	S.19

# EQUIPMENT

## New Vectra SRi Nav model

An additional model to the New Vectra range is the SRi Nav, which features the CD 70 stereo radio/CD with MP3 capability/satellite navigation with colour monitor as standard.

## SRi/SRi Nav with Exterior pack\*

New Vectra SRi/SRi Nav with Exterior pack models feature the VXR Styling pack one and 19-inch five-spoke alloy wheels with 235/35 R 19 ultra-low profile tyres as standard.

\* = SRi Exterior pack models are not available with the 3.0CDTi V6 engine.



Foldable key.



Six airbags.



Remote control security alarm.

## Model availability

	New Vectra					New Signum			
	Life	Exclusiv	Design	Elite	SRi	Elegance	Exclusiv	Design	Elite
4-door saloon	■		■						
5-door hatchback	■	■	■	■	■				
5-door estate	■	■	■	■	■				
5-door executive hatch						■	■	■	■

■ = This model is available with this bodystyle.

## Safety

**Standard features** • Driver's airbag • Front passenger's airbag • Front seat side-impact airbags • Full-size curtain airbags • Anti-lock Braking System (ABS) • Electronic Brakeforce Distribution (EBD) • Cornering Brake Control (CBC) – see **D7** on page S.17 • Emergency Brake Assist (EBA) – Increases brake force applied in emergency braking situations – see **D6** on page S.16 • Active-safety front seat head restraints • Height-adjustable head restraints on outer rear seats • Five lap and diagonal inertia-reel seatbelts (height-adjustable front and outer rear) • Pyrotechnic front and outer rear body-lock seatbelt pretensioner system – Tightens the seatbelt during the early stages of a frontal impact • Front seatbelt force limiters – Reduces potential upper body injuries during a frontal impact • Outer rear seatbelt force limiters (excludes Vectra estate) • ISOFIX child seat system for outer rear seats (does not include child seat) – Secures ISOFIX child safety seats to the vehicle itself, virtually eliminating the dangers that can result from improper installation • Anti-submarining ramps in all seats – Help prevent occupants sliding underneath the lap belt during a collision • Energy-absorbing steering column • Pedal release system – Reduces potential injury to the driver's legs and feet during a severe frontal impact • Laminated windscreen • Side-impact protection beams • Integral protective side door padding • Reinforced passenger safety cell • Deformation zones front and rear • Child-proof locks on rear doors • Burst-proof door locks and anti-jam door design • Adaptive Brake Lights (ABL) – If the driver brakes hard enough to activate the ABS function the brake lights flash on and off at a frequency of four times per second, thus warning following vehicles that heavy braking is in progress.

Additional features	New Vectra					New Signum			
	Life	Exclusiv	Design	Elite	SRi	Elegance	Exclusiv	Design	Elite
Trailer Stability Programme (TSP)	□	□	□	□	□	□	□	□	□
Electronic Stability Programme (ESP-plus) incorporating traction control <b>D1</b>	○	○	○	○ <sup>1</sup>	○ <sup>1</sup>	○	○	○ <sup>1</sup>	○ <sup>1</sup>
Isolation facility for electrically operated rear windows			●	●		●	●	●	●
Electronic park/brake pedal safety interlock on models with automatic transmission	●	●	●	●	●	●	●	●	●
Height-adjustable centre rear seat head restraint			●	●		●	●	●	●

● = Standard equipment  
○ = Optional at extra cost.  
□ = Only available as part of an extra-cost option pack.  
See page S.8 for details.

<sup>1</sup> = ESP-plus is standard on V6 models and available as an extra-cost option on all other models.  
<sup>2</sup> = Sunroof deletes storage pocket between sunvisors.

<sup>3</sup> = Check control warning display features engine oil level, engine coolant level, automatic transmission control (where fitted), front brake pad wear, windscreen washer fluid level, bulb test for head/tail and brake lights, and brake lights fuse. Trip computer features instantaneous and average fuel consumption, fuel consumed, average speed, distance travelled and range based on fuel remaining.

## Electronic Stability Programme-plus (ESP-plus)

**D1.** ESP-plus provides enhanced yaw compensation during understeer or oversteer. The system works by monitoring the front and rear of the car, comparing their respective directions of travel going in to the bend with the input received through the steering wheel. If the vehicle starts to slide, it applies corrective braking to the appropriate wheel, or wheels, compensating for the slide and helping you regain control more rapidly.

ESP-plus offers additional safety in the form of 2-way traction control, which prevents the driving wheels from spinning, under acceleration, on slippery surfaces.

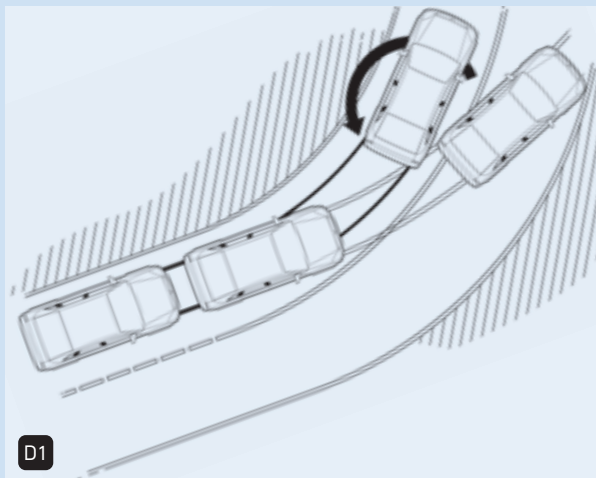

## Security

**Standard features** • Remote control ultrasonic security alarm system • Remote control central deadlocking (doors, boot lid/tailgate, petrol/diesel fuel flap) • Visible Vehicle Identification Number (VIN) plate • 'Key left in ignition' audible warning • Freewheeling driver's door lock • Electronic engine deadlock immobiliser • Door-to-door illumination – Keeps the headlights and rear lights on for 30 seconds after the car doors are locked • Foldable key • Electronic theft protection for audio equipment • Driver's internal central locking switch

Additional feature	New Vectra					New Signum			
	Life	Exclusiv	Design	Elite	SRi	Elegance	Exclusiv	Design	Elite
Locking wheel bolts for alloy wheels (where fitted)	○	□	●	●	●	●	●	●	●

## Interior features

**Standard features** • Front and rear tilting assist handles with damped retraction and coat hooks • Chrome internal door handles • Colour-keyed fleece velour carpet • Lidded glovebox • Front door pockets • Hinged luggage compartment cover (hatchback) • Retractable luggage compartment cover (estate/Signum) • Fully carpeted luggage area • Carpeted rear seat back • Boot/luggage area sill protection • Load restraint lashing eyes • 12-volt auxiliary power socket behind front seats • Drinks holders in centre console

Additional features	New Vectra					New Signum			
	Life	Exclusiv	Design	Elite	SRi	Elegance	Exclusiv	Design	Elite
Twin sunvisors incorporating front passenger's vanity mirror with cover	●	●			●				
Twin sunvisors incorporating illuminated driver's and front passenger's vanity mirrors with covers			●	●		●	●	●	●
Charcoal metallic-effect inserts on facia and doors	●								
Charcoal metallic/aluminium-effect inserts on facia and doors		●			●	●	●	●	
Charcoal metallic/fineline dark inserts on facia and doors (with Charcoal interior trim)			●	●					●
Wood-effect inserts on facia and doors (with Beige interior trim)				●					●
Leather-covered gear knob (manual gearboxes only)			●	●	●		●	●	●
Electro-chromatic anti-dazzle rear-view mirror			●	●				●	●
Storage pocket between sunvisors <sup>2</sup>			●	●		●	●	●	●
Rear seat drinks holders			●	●	●	●	●	●	●

## Facia, instruments and controls

**Standard features** • Cruise control • Rev counter • Automatic self-correcting RDS-time clock • Multi-function display panel showing time, date, outside air temperature (with ice warning) and audio display • Steering column adjustable for reach and rake • Electronic odometer and trip odometer • Instrument panel light dimmer • Coolant temperature gauge • Handbrake-on/low brake fluid level and low fuel level warning lights

Additional features	New Vectra					New Signum			
	Life	Exclusiv	Design	Elite	SRi	Elegance	Exclusiv	Design	Elite
Driver information centre incorporating check control warning display and multi-function trip computer <sup>3</sup>			●	●	●	●	●	●	●
Three-spoke steering wheel	●	●							
Three-spoke leather-covered steering wheel			●	●		●	●		●
Three-spoke leather-covered sports steering wheel					●			●	
Sports instruments					●			●	

## Interior lighting

Features	New Vectra					New Signum			
	Life	Exclusiv	Design	Elite	SRi	Elegance	Exclusiv	Design	Elite
Fade up/fade down courtesy lights operated by front and rear door switches	●	●	●	●	●	●	●	●	●
Illuminated luggage area and glovebox	●	●	●	●	●	●	●	●	●
Map reading lights integral with front courtesy light			●	●		●	●	●	●
Two rear reading lights			●	●		●	●	●	●
Indirect night lighting			●	●				●	●

# EQUIPMENT



Electrically heated front seats.



Electronic Climate Control (ECC).



Rain-sensitive windscreen wipers.

## Seating and upholstery (see pages 40-41 for details)

**Standard features** • Driver's seat with reach, rake, height, tilt and lumbar adjustment • Front passenger's seat with reach and rake adjustment • Rear seat fold-down centre armrest and load-through facility • Adjustable front centre armrest with storage facility • Storage pockets on front seat backs

Additional features	New Vectra					New Signum			
	Life	Exclusiv	Design	Elite	SRI	Elegance	Exclusiv	Design	Elite
Champion cloth seat trim	●								
Scala cloth seat trim		●				●	●		
Duke cloth seat trim					●				
Alpha cloth/Morrocana seat trim			●						
Draht cloth/leather seat trim								●	
Leather seat trim <sup>4</sup>				●					●
Electrically heated front seats with variable temperature settings				●					●
Sports front seats					●			●	
Front passenger's seat with height, tilt and lumbar adjustment			●	●				●	●

## Rear seating and FlexSpace®

Features	New Vectra					New Signum			
	Life	Exclusiv	Design	Elite	SRI	Elegance	Exclusiv	Design	Elite
Boot/luggage area sill protection	●	●	●	●	●	●	●	●	●
Load restraint lashing eyes	●	●	●	●	●	●	●	●	●
Fold-out rear seat centre armrest	●	●	●	●	●	●	●	●	●
Rear seat drinks holders			●	●	●	●	●	●	●
Two rear reading lights			●	●		●	●	●	●
12-volt auxiliary power socket in luggage compartment (estate)			●	●	●				
Individual outer rear seats with fore and aft and recline adjustment <sup>D2</sup>						●	●	●	●
Centre rear seat concealing storage console						●	●	●	●
60/40 split-folding rear seat back	●	●	●	●	●				
40/20/40 split-folding rear seat back <sup>D2</sup>						●	●	●	●
Rear seats with individual fold-flat facility <sup>D2</sup>						●	●	●	●
Vertical load-restraining net (estate <sup>5</sup> /Signum)	○	○	○	○	○	○	○	○	○

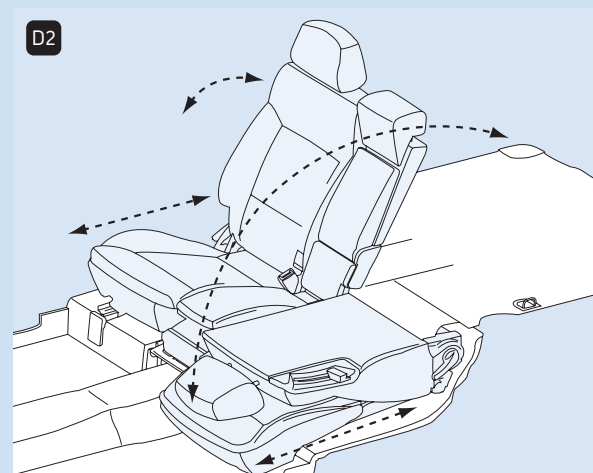

### New Signum FlexSpace® rear seating

**D2.** New Signum's rear centre seat is ideal for that occasional fifth passenger. Alternatively you can swivel the padded section to reveal a useful storage console. There's even a pair of built-in drinks holders. Naturally, the seat comes with its own lap and diagonal inertia-reel seatbelt, cleverly concealed in the headlining.

The two individual rear seats are fully contoured, front seat-style, for optimum comfort and support and can be slid back and forth by up to 130mm to achieve the desired mix of legroom/luggage space. In addition, a recline facility for the two individual rear seats lets your passengers achieve their most comfortable travelling position.

The rear seat itself is split 40/20/40 to provide ample space for passengers and/or luggage. The seat cushions of the two individual outer rear seats slide forward as the backs fold in a simple, one-handed movement, creating a large flat load floor.

## Heating and ventilation

**Standard features** • Air blend heater with four-speed fan • Side window demist vents and adjustable face-level air vents • Air recirculation system with activation light • Interior pollen filter

Additional features	New Vectra					New Signum			
	Life	Exclusiv	Design	Elite	SRI	Elegance	Exclusiv	Design	Elite
Air-conditioning	●	●			●	●	●	●	
Automatic air-conditioning			●						
Electronic Climate Control (ECC) incorporating air-conditioning with variable side-to-side temperature settings and dual zone sun sensor				●					●
Rear passenger compartment heating ducts			●	●					●

## Exterior and convenience features

**Standard features** • Electrically operated front windows with safety autoreverse and one-touch facility • Twin electrically adjustable/heated door mirrors (wide-angle on driver's side) with automatic timed cut-off • Green-tinted glass • Heated rear window with automatic timed cut-off • Intermittent rear window wash/wipe (hatchback/estate/Signum) • Twin-jet windscreen washer nozzles • Twin gas-assisted tailgate struts (hatchback/estate/Signum) • Foldable door mirrors

Additional features	New Vectra					New Signum			
	Life	Exclusiv	Design	Elite	SRI	Elegance	Exclusiv	Design	Elite
Rain-sensitive windscreen wipers with sensitivity adjustment and flick-wipe			●	●				●	●
Electro-chromatic anti-dazzle driver's door mirror			●	●				●	●
Two-tone horn		●	●	●	●	●	●	●	●
Electrically operated rear windows with safety autoreverse and child isolation facility			●	●		●	●	●	●
Electrically operated slide/tilt glass sunroof with multi-position pre-set facility and interior blind		○	○ <sup>2</sup>	○ <sup>2</sup>	○	○ <sup>2</sup>	○ <sup>2</sup>	○ <sup>2</sup>	○ <sup>2</sup>
Front and rear parking distance sensors		○	○	○	○	○	○	○	○
Two-coat metallic or pearlescent paint	○	○	○	○	○	○	●	○	○
Black roof rails (estate)	○								
Silver-effect roof rails (estate/Signum)		○	○	●	○	○	●	○	●
Dark-tinted Solar Protect® glass (excludes windscreen and front door windows) (estate/Signum)					●	●	●	●	●
Detachable tow bar (saloon/hatchback/Signum) <sup>6</sup>	□	□	□	□	□	□	□	□	□
Retractable tow bar (estate) <sup>6</sup>	□	□	□	□	□				
Power tailgate (estate)			●	●					

## Mechanical

**Standard features** • Electro-hydraulic power-assisted steering (EHPS) • Lightweight MacPherson strut front suspension and multi-link rear suspension with gas-pressure dampers • Catalytic converter

Additional features	New Vectra					New Signum			
	Life	Exclusiv	Design	Elite	SRI	Elegance	Exclusiv	Design	Elite
Five-speed manual gearbox (1.8i 16v VVT only)	●	●	●		●	●	●		
Six-speed manual gearbox (exc. 1.8i 16v VVT)	●	●	●	●	●	●	●	●	●
Five-speed automatic transmission with Active Select function (2.2i 16v Direct models)			○	○	○	○	○	○	○
Six-speed automatic transmission with Active Select function (2.8i V6 24v Turbo/1.9CDTi 16v (150PS)/3.0CDTi V6 24v models)	○	○	○	○	○	○	○	○	○
Lowered and uprated sports suspension					●		●	●	
Interactive Driving System-plus (IDS-plus) with Continuous Damping Control (CDC) and Sport switch <sup>7,8</sup> <b>D5</b> – see page S.11		○	○	○	○	○	○	○	○
Automatic self-levelling rear suspension <sup>7</sup>	□	□	□	□	□	□	□	□	□

● = Standard equipment.  
○ = Optional at extra cost.  
□ = Only available as part of an extra-cost option pack. See page S.8 for details.  
2 = Sunroof deletes storage pocket between sunvisors.  
4 = The following items are upholstered in leather: seat facings and door armrests.

5 = Fixing points for accessory dog guard are also included on Vectra estate models.  
6 = Please note a separate electrical adaptor (13 pin to 7 pin) is required – available as an accessory at extra cost. This adaptor does not allow for supplementary trailer power requirements.

7 = Automatic self-levelling rear suspension is not available in conjunction with 18/19-inch alloy wheels, IDS-plus or sports suspension.  
8 = Available on 2.0i 16v Turbo, 2.2i 16v Direct and 1.9CDTi 16v (150PS) models fitted with either optional ESP-plus or Towing pack and V6 models.



# EQUIPMENT



Sport switch.



Adaptive Forward Lighting (AFL).



Electro-chromatic anti-dazzle rear-view mirror.

## Exterior lighting

**Standard features** • Lights-on audible warning • LED centre brake light • Twin reversing lights, rear fog light, hazard warning lights, side repeat indicators • Dual Ellipsoidal (DE) headlights • Electric headlight beam levelling

Additional features	New Vectra					New Signum			
	Life	Exclusiv	Design	Elite	SRI	Elegance	Exclusiv	Design	Elite
Adaptive Forward Lighting (AFL) incorporating xenon headlights with dynamic beam levelling and high-pressure headlight washers <b>D3</b> <b>D4</b>		○	○	○	○	○	○	○	○
Ellipsoidal halogen front fog lights			●	●	●		●	●	●
Automatic Lighting Control (ALC)			●	●				●	●

## Exterior styling and protection

**Standard features** • Chrome-effect upper grille surround • Body-colour front and rear bumpers • Body-colour door mirrors • Body-colour side-protection mouldings • Tailgate/boot lid push-lock • Body-colour sports sill mouldings and rear lower skirt (excludes estate)

Additional features	New Vectra					New Signum			
	Life	Exclusiv	Design	Elite	SRI	Elegance	Exclusiv	Design	Elite
Chrome-effect lower grille surround						●	●	●	●
Chrome-effect front fog light surrounds							●	●	●
Chrome-effect window trim		●	●	●	●	●	●	●	●
Body-colour door handles		●	●		●	●	●	●	
Chrome-effect door handles				●					●
Body-colour rear lip spoiler (hatchback only)					●				
Body-colour sports front air dam		●	●	●	●	●	●	●	●
Dark-style headlights, tail lights and LED centre brake light with grey indicators and side repeaters					●			●	
White indicators and side repeaters		●	●	●		●	●		●
Visible stainless steel exhaust tailpipe (hatchback/Signum)					●			●	
Visible dual branch stainless steel exhaust tailpipes (hatchback/Signum) (2.0i 16v Turbo/2.8i V6 24v Turbo/3.0CDTi V6 24v)					● <sup>9</sup>	●		● <sup>9</sup>	●

● = Standard equipment.  
○ = Optional at extra cost.  
□ = Only available as part of an extra-cost option pack.  
See page S.8 for details.

7 = Automatic self-levelling rear suspension is not available in conjunction with 18/19-inch alloy wheels, IDS-plus or sports suspension.  
9 = Also fitted to 2.2i 16v Direct models.  
10 = Also available as part of an extra-cost option pack.  
See page S.8 for details.

11 = Includes sports suspension.  
12 = Not available on 3.0CDTi V6 24v models. The optional 19-inch alloy wheels will affect the fuel consumption and CO<sub>2</sub> emissions. This may have an effect on the VED band and/or benefit in kind taxation. See page S.12 for details of fuel consumption and CO<sub>2</sub> emissions.  
13 = Standard on SRI/SRI Nav with Exterior pack models.

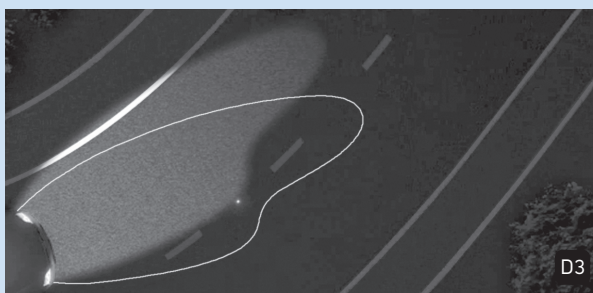

D3

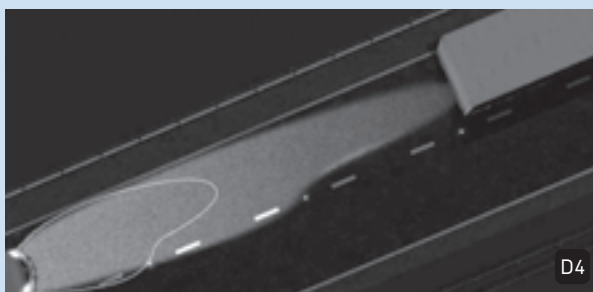

D4

### Adaptive Forward Lighting (AFL)

Adaptive Forward Lighting is a sophisticated new lighting system that allows drivers to see around corners and see further ahead at motorway speeds. This optional bi-xenon system employs two main functions:

#### Curving Light

**D3.** Controlled by a combination of steering wheel movement and sensors for the vehicle's speed and yaw angle, the Curving Light function allows the headlight beam to move up to 15 degrees left or right of the straight ahead position. This ensures the light is always following the trajectory plotted by the front wheels, rather than simply pointing straight ahead.

#### Motorway Light

**D4.** At speeds above 65mph, AFL raises the dipped headlight beam to extend the range of vision for increased safety at higher speed. The beam automatically returns to its normal position when the car falls below that speed.

## Wheels and tyres

Features	New Vectra					New Signum			
	Life	Exclusiv	Design	Elite	SRI	Elegance	Exclusiv	Design	Elite
16-inch steel wheels with flush wheel covers and 205/55 R 16 ultra-low profile tyres	●								
16-inch five-spoke alloy wheels with locking bolts and 205/55 R 16 ultra-low profile tyres	○								
16-inch Structure wheels with 215/55 R 16 ultra-low profile tyres		●							
16-inch 10-spoke alloy wheels with 215/55 R 16 ultra-low profile tyres			●						
17-inch seven-spoke alloy wheels with locking bolts and 215/50 R 17 ultra-low profile tyres		□	□			●			
17-inch five-spoke alloy wheels with locking bolts and 215/50 R 17 ultra-low profile tyres				●					●
17-inch 10-spoke alloy wheels with locking bolts and 215/50 R 17 ultra-low profile tyres					●			●	
18-inch multi-spoke alloy wheels with locking bolts and 225/45 R 18 ultra-low profile tyres <sup>7</sup>									○ <sup>11</sup>
18-inch 11-spoke alloy wheels with locking bolts and 225/45 R 18 ultra-low profile tyres <sup>7</sup>			○ <sup>11</sup>	○ <sup>10,11</sup>		○ <sup>11</sup>	●		
19-inch five-spoke alloy wheels with locking bolts and 235/35 R 19 ultra-low profile tyres <sup>7,12</sup>					○ <sup>10,13</sup>			○	
Space-saver steel spare wheel/tyre	●	●	●	●	●	●	●	●	●
Tyre valve cap tool located behind fuel flap	●	●	●	●	●	●	●	●	●



W1

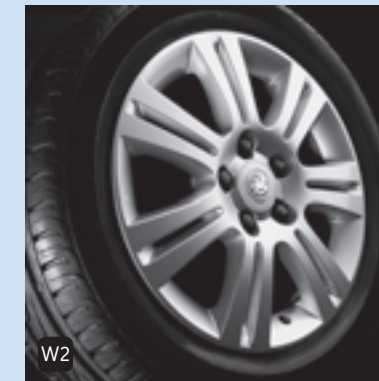

W2



W3



W4



W5

**W1.** 16-inch five-spoke alloy wheel, optional on Life models.  
**W2.** 17-inch seven-spoke alloy wheel, optional as part of Plus pack on Vectra Exclusiv and Design models.  
**W3.** 18-inch 11-spoke alloy wheel, optional on Vectra Design/Elite and Signum Elegance.  
**W4.** 18-inch multi-spoke alloy wheel, optional on Signum Elite models.  
**W5.** 19-inch alloy wheel, standard on Vectra SRI/SRI Nav with Exterior pack, optional on Vectra SRI and Signum Design models.



Standard on all Signum models and Vectra Elite/SRi Nav

Option packs

	New Vectra					New Signum			
	Life	Exclusiv	Design	Elite	SRi	Elegance	Exclusiv	Design	Elite
<b>Plus pack</b> • 17-inch alloy wheels (steel space-saver spare) with 215/50 R 17 tyres • CDC 40 stereo radio with Digital Audio Broadcast (DAB)/integral six-disc CD autochanger/graphic display • Front fog lights		○							
<b>Plus pack</b> • 17-inch alloy wheels (steel space-saver spare) with 215/50 R 17 tyres • CD 70 stereo radio/CD with MP3 capability/satellite navigation system with colour monitor			○						
<b>Plus pack</b> • 18-inch alloy wheels (steel space-saver spare) with 225/45 R 18 tyres • Electrically operated slide/tilt glass sunroof with multi-position pre-select facility <sup>2</sup>				○ <sup>11</sup>					
<b>Plus pack</b> <sup>12,14</sup> • 19-inch alloy wheels (steel space saver spare) with 235/35 R 19 tyres • CDC 40 stereo radio with Digital Audio Broadcast (DAB)/integral six-disc CD autochanger/graphic display					○				
<b>VXR Styling pack one</b> (hatch/estate) • Front lower spoiler • Rear spoiler • Side sills (pair) • Rear lower skirt • Visible stainless steel exhaust tailpipe (hatch)		○	○	○	○ <sup>13</sup>				
<b>Towing pack</b> (hatch/saloon) • Electronic Stability Programme-plus (ESP-plus) incorporating traction control • Trailer Stability Programme • Automatic self-levelling rear suspension <sup>7</sup> • Detachable tow bar <sup>6</sup>	○	○	○	○ <sup>15</sup>	○ <sup>15</sup>	○	○	○ <sup>15</sup>	○ <sup>15</sup>
<b>Towing pack</b> (estate) • Electronic Stability Programme-plus (ESP-plus) incorporating traction control • Trailer Stability Programme • Automatic self-levelling rear suspension <sup>7</sup> • Retractable tow bar <sup>6</sup>	○	○	○	○ <sup>15</sup>	○ <sup>15</sup>				
<b>FlexOrganiser® organiser pack</b> (estate) • 3D storage net • Side net pocket • Four side rail hooks	○	○	○	○	○				
<b>FlexOrganiser® divider pack</b> (estate) • Vertical divider mesh • Divider rods • Two side rail hooks	○	○	○	○	○				

● = Standard equipment.  
○ = Optional at extra cost.

2 = Sunroof deletes storage pocket between sunvisors.  
6 = Please note: a separate electrical adaptor (13-pin to 7-pin) is required – available as an accessory at extra cost. This adaptor does not allow for supplementary trailer power requirements.  
7 = Automatic self-levelling rear suspension is not available in conjunction with 18/19-inch alloy wheels, IDS-plus or sports suspension.  
10 = Also available as part of an extra-cost option pack. See above for details.  
11 = Includes sports suspension.  
12 = Not available on 3.0CDTi V6 24v models. The optional 19-inch alloy wheels will affect the fuel consumption and CO<sub>2</sub> emissions. This may have an effect on the VED band and/or benefit in kind taxation. See page S.12 for details of fuel consumption and CO<sub>2</sub> emissions.  
13 = Standard on SRi/SRi Nav with Exterior pack models.  
14 = Not available on SRi Nav models.  
15 = ESP-plus is standard on 2.8i V6 24v Turbo/3.0CDTi V6 24v models.  
16 = Fitted in lieu of CD 70 audio system. Deletes the satellite navigation function.  
17 = Standard on SRi Nav models.  
18 = Deletes drinks holders in centre console. Does not include phone or cradle.

Audio and communications

**Standard features** • Radio data system (RDS EON) with Traffic Programme • Remote audio display • Roof-mounted flexible aerial • FM and MW reception • Steering wheel mounted audio controls

Additional features	New Vectra					New Signum			
	Life	Exclusiv	Design	Elite	SRi	Elegance	Exclusiv	Design	Elite
CD 30 stereo radio/CD player/six speakers (seven speakers on SRi models) (17 watts per channel)	●	●			●				
CDC 40 stereo radio with Digital Audio Broadcast (DAB) facility/integral six-disc CD autochanger/graphic display/seven speakers (35 watts per channel)	○	○ <sup>10</sup>	●	N/C <sup>16</sup>	○ <sup>10,14</sup>	N/C <sup>16</sup>	N/C <sup>16</sup>	N/C <sup>16</sup>	N/C <sup>16</sup>
CD 70 stereo radio/CD with MP3 capability/satellite navigation with colour monitor/seven speakers (20 watts per channel)	○	○	○ <sup>10</sup>	●	○ <sup>17</sup>	●	●	●	●
Mobile phone system with Bluetooth <sup>®18</sup>	○	○	○	○	○	○	○	○	○

**Digital Audio Broadcast (DAB)**  
Now widely available in the UK, digital audio broadcasts offer the user a variety of advantages over traditional FM, starting with the digital quality sound which is immune to any hiss or crackle. You'll often find a broader range of stations on offer too, many of which are not available on FM, and listening to them couldn't be easier – you simply select the station, by name, from the displayed list, thus removing the need to retune or look for stations when travelling around. Some stations will even display the artists' names and song titles on the car's graphic display, while they're played. To further help you appreciate the digital sound, our CDC 40 DAB-compatible audio unit offers 35 watts per channel and plays through our highest quality seven-speaker system.

**Mobile phone system**  
Vauxhall's factory-fit dual-band mobile phone system has been considerably enhanced. Now fully integrated into the audio and communication system, it also features voice control and will connect wirelessly to phones with Bluetooth<sup>®</sup> technology. All the required information is displayed on the graphic information display when a mobile phone is in use, while the menus are easily navigated by either the steering wheel audio controls or the multi-function button on the radio. Certain functions can also be controlled by voice activation. Mounted on the centre console, the phone system base unit can be fitted with cradles (available as accessories) for many different mobile phones. Contact your Vauxhall retailer for information regarding compatible mobile phones.

**MP3 CD player**  
An MP3 is a compressed sound or music file which, due to its small size, takes up less space on a compact disc, which means that more tracks can be recorded onto a CD. It's possible to fit almost 10 hours of music onto one CD, and, in a way, turns a single-disc CD/MP3 player into a multi-disc autochanger. Providing you have access to a compatible computer to create the MP3 tracks, you can compress your CD collection and create your own compilations – and you won't have to drive around with all your original CDs in the car.

**Satellite navigation**  
Vauxhall's CD-ROM-driven satellite navigation systems have been widely acclaimed for their ease of use and high level of information. The colour monitor has a split-screen facility to display half the screen as a map and half as easy-to-follow directional arrows. The audible direction guidance prompt gives details of road numbers and motorway junction numbers, while you can also plan your route to avoid toll roads, if required. The CD 70 also features Traffic Message Channel (TMC), a specific application of RDS used for broadcasting real-time traffic information, delivered to the driver either visually or verbally. TMC can also offer dynamic route guidance – alerting the driver to a problem on the planned route and calculating an alternative route to avoid the incident.

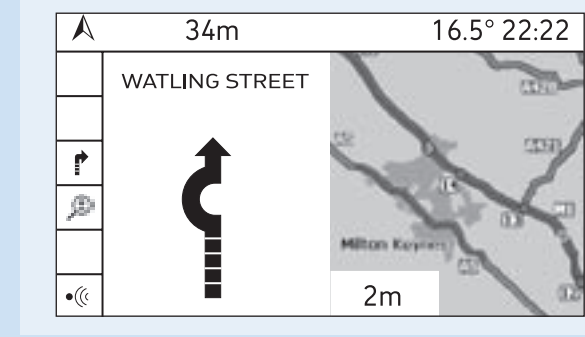

**Standard features (CD 70)** • Automatic re-routing on request • CD-ROMs available for all major European countries • Exact location of vehicle using the GPS (Global Positioning System) and speed sensor • Choice of four different route types • Store up to 100 personal destinations • Last 10 destinations stored automatically

# TECHNICAL DATA



## 330Nm

New 2.8i V6 24v Turbo – maximum torque at only 1800rpm



## 184PS

3.0CDTi V6 24v – now more powerful and more efficient



## 6-SPEED

Six-speed manual and automatic transmissions widely available

### Petrol engines

	1.8i 16v VVT ECOTEC-4	2.2i 16v Direct ECOTEC-4 aluminium	2.0i 16v Turbo ECOTEC-4 aluminium	2.8i V6 24v Turbo ECOTEC-4 aluminium
Capacity	1796cc	2198cc	1998cc	2792cc
Maximum power	140PS (103kW) @ 6300rpm	155PS (114kW) @ 5600rpm	175PS (129kW) @ 5500rpm	230PS (169kW) @ 5500rpm
Maximum torque	175Nm (129 lb.ft.) @ 3800rpm	220Nm (162 lb.ft.) @ 3800rpm	265Nm (195 lb.ft.) @ 2500rpm	330Nm (243 lb.ft.) @ 1800rpm
Compression ratio	10.5:1	12.0:1	9.5:1	9.5:1
Emission compliance	Euro 4	Euro 4	Euro 4	Euro 4
Layout	4 cylinders 4 valves per cylinder Double overhead camshafts	4 cylinders 4 valves per cylinder Double overhead camshafts	4 cylinders 4 valves per cylinder Double overhead camshafts	6 cylinders 4 valves per cylinder Double overhead camshafts
Construction	Alloy cylinder head Cast iron cylinder block	Alloy cylinder head Alloy cylinder block	Alloy cylinder head Alloy cylinder block	Alloy cylinder heads Alloy cylinder block
Fuel system	Multi-point sequential fuel injection with high-pressure fuel pump	Multi-point sequential direct fuel injection with high-pressure fuel pump	Multi-point sequential fuel injection with air mass metering	Multi-point sequential fuel injection with air mass metering
Induction system	Naturally aspirated Variable Valve Timing (VVT)	Naturally aspirated	Water-cooled turbocharger with intercooler	Water-cooled twin-scroll turbocharger with intercooler
Throttle control	Electronic cable-free 'drive by wire'			
Service interval	20,000 miles or 1 year (whichever occurs sooner)			

### Benefit in kind company car taxation percentage rates – 2006/07 tax year

	Hatchback/Saloon/Estate/Signum			
Manual*	21/21/23/23	23/23/24/25	28/-/29/29	-/-/-/35
Automatic*	-/-/-/-	25/25/26/26	-/-/-/-	35/-/35/35

### Diesel engines

	1.9CDTi (120PS) ECOTEC-4 turbo diesel	1.9CDTi 16v (150PS) ECOTEC-4 turbo diesel	3.0CDTi V6 24v ECOTEC-V6 turbo diesel
Capacity	1910cc	1910cc	2958cc
Maximum power	120PS (88kW) @ 3500rpm	150PS (110kW) @ 4000rpm	184PS (135kW) @ 4000rpm
Maximum torque	280Nm (206 lb.ft.) @ 2000-2750rpm	320Nm (235 lb.ft.) @ 2000-2750rpm	400Nm (295 lb.ft.) @ 1900-2700rpm
Compression ratio	18.0:1	17.5:1	18.5:1
Emission compliance	Euro 4	Euro 4	Euro 4
Layout	4 cylinders 2 valves per cylinder Single overhead camshaft	4 cylinders 4 valves per cylinder Double overhead camshafts	6 cylinders 4 valves per cylinder Double overhead camshafts
Construction	Alloy cylinder head Cast iron cylinder block	Alloy cylinder head Cast iron cylinder block	Alloy cylinder heads Cast iron cylinder block
Fuel system	Common rail fuel injection system with high-pressure pump		
Induction system	Turbocharger with Variable Nozzle Turbine (VNT)		
Throttle control	Electronic cable-free 'drive by wire'		
Service interval	20,000 miles or 1 year (whichever occurs sooner)		

### Benefit in kind company car taxation percentage rates – 2006/07 tax year

	Hatchback/Saloon/Estate/Signum		
Manual*	20/20/21/21	21/21/21/22	27/-/27/27
Automatic*	-/-/-/-	27/27/27/27	28/-/28/28

-- This engine/body style/transmission combination is not available.

\* = For details of benefit in kind percentage rates relating to models fitted with optional 19-inch alloy wheels please refer to the Vauxhall Car and Accessory Price Guide.

### Transmissions

- Front-wheel drive
- Hydraulically actuated, asbestos-free single-plate clutch

**Five-speed manual gearbox:** standard on 1.8i 16v VVT models.

**Six-speed manual gearbox:** standard on all models, excluding 1.8i 16v VVT and 2.8i V6 24v Elite.

**Five-speed automatic transmission with Active Select function:** available at extra cost on 2.2i 16v Direct models. Electronically controlled with adaptive driving function and winter mode. Fluid drive with torque converter, lock-up clutch, neutral control fuel-saving feature and Active Select.

**Six-speed automatic transmission with Active Select function:** standard on 2.8i V6 24v Turbo Elite models and available at extra cost on 1.9CDTi 16v (150PS)/3.0CDTi V6 24v models. Electronically controlled with adaptive driving function and winter mode. Fluid drive with torque converter, lock-up clutch, neutral control fuel-saving feature and Active Select.

### Electrics

#### Alternator:

1.9CDTi/1.9CDTi 16v – 100A.

1.8i 16v VVT/2.2i 16v Direct/2.0i 16v Turbo – 120A.

2.8i V6 24v Turbo/3.0CDTi V6 24v – 140A.

#### Maintenance-free battery:

1.8i 16v VVT – 55Ah.

1.9CDTi/1.9CDTi 16v/2.8i V6 24v Turbo – 70Ah.

2.2i 16v Direct/2.0i 16v Turbo/

3.0CDTi V6 24v – 85Ah.

### Fuel tank capacity

- Vectra hatchback/saloon – 61 litres (13.4 gallons)
- Vectra estate/Signum – 60 litres (13.2 gallons)

### Suspension

**Front:** Independent. Lightweight MacPherson struts with gas-pressure dampers and coil springs. Anti-roll bar. Lightweight aluminium uprights and control arms.

- Vectra SRi/Signum Exclusiv and Design – uprated springs and dampers with lower ride height

**Rear:** Lightweight multi-link with rising-rate steel double cone mini-block coil springs and gas-pressure dampers. Aluminium lower control arm/upright reduces unsprung weight for enhanced ride/roadholding. Compact packaging ensures minimal intrusion into luggage area. Mounting bushes feature high lateral and low longitudinal stiffness for optimum roadholding and comfort.

- Vectra SRi/Signum Exclusiv and Design – uprated springs and dampers with lower ride height
- Vectra Life, Design and Elite/Signum Elegance and Elite – automatic self-levelling rear suspension option

### Body

- Aerodynamic drag co-efficients:

Hatchback/Saloon – Cd 0.29

Estate – Cd 0.32

Signum – Cd 0.33

- Aluminium and magnesium components utilised to reduce weight
- Extensive use of dual-phase steels
- Polypropylene front and rear bumpers capable of withstanding minor impacts up to 2.5mph without permanent deformation
- High strength alloy steel B-pillar

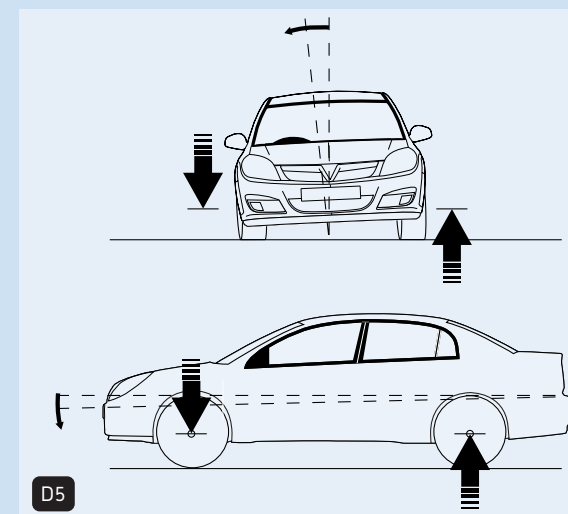

### Interactive Driving System-plus (IDS-plus) with Continuous Damping Control (CDC)

**D5.** The Interactive Driving System (IDS-plus) chassis offers the driver an even more sporting driving experience, thanks mainly to the electronic control of the suspension. Pressing the Sport switch activates the CDC function – CDC monitors the roll, pitch and yaw of the car, and changes the rate of damping on each wheel to optimise the handling, effectively stiffening the suspension – but selectively. This means the vehicle will exhibit a reduced rate of roll and pitch, making it more responsive during direction changes and more settled during the braking/turn-in/acceleration transition when cornering. CDC is a major breakthrough in the segment.

### Sport switch

**D5.** The functions of the Sport switch aren't limited to suspension control. When activated, it also affects the steering and accelerator pedal. The drive by wire throttle is altered electronically, leading to a sharper engine response and crisper acceleration, while the map of the power assisted steering is also adjusted, giving the driver a more positive initial turn-in on corner-entry.



# TECHNICAL DATA AND WARRANTIES



## 60.1mpg

Vectra 1.9CDTi (120PS) engine is both powerful and economical



## 7.1secs

Signum 2.8i V6 24v Turbo 0-60mph



## 5.3secs

Vectra 3.0CDTi V6 24v 30-50mph, great torque and flexibility

### New Vectra performance, fuel economy and emissions

	Performance (manufacturer's figures)			Wheel size (inches)	Fuel economy mpg (litres/100km)			CO <sub>2</sub> emissions g/km
	Maximum speed (mph)	Acceleration (sec) 0-60mph	30-50mph (4th gear)		Urban driving	Extra-urban driving	Combined figure	
<b>Manual gearbox</b>								
1.8i 16v VVT hatch/saloon	131	10.2	8.6	16/17/18	28.0 (10.1)	51.4 (5.5)	39.2 (7.2)	173
				19	27.7 (10.2)	50.4 (5.6)	38.7 (7.3)	175
1.8i 16v VVT estate	126	10.7	9.2	16/17/18	27.4 (10.3)	47.9 (5.9)	37.7 (7.5)	180
				19	27.2 (10.4)	47.1 (6.0)	37.2 (7.6)	182
2.2i 16v Direct hatch/saloon	135	8.6	7.5	16/17/18	27.4 (10.3)	47.9 (5.9)	37.7 (7.5)	180
				19	27.2 (10.4)	47.1 (6.0)	37.2 (7.6)	182
2.2i 16v Direct estate	130	8.9	7.2	16/17/18	26.6 (10.6)	45.6 (6.2)	36.2 (7.8)	187
				19	26.4 (10.7)	44.8 (6.3)	35.8 (7.9)	190
2.0i 16v Turbo hatch	143	8.1	5.5	17/18	22.6 (12.5)	44.8 (6.3)	32.8 (8.6)	206
				19	22.4 (12.6)	44.1 (6.4)	32.5 (8.7)	209
2.0i 16v Turbo estate	139	8.4	5.9	17/18	22.2 (12.7)	43.5 (6.5)	32.1 (8.8)	211
				19	22.1 (12.8)	42.8 (6.6)	31.7 (8.9)	214
1.9CDTi (120PS) hatch/saloon	124	10.5	7.5	16/17/18	38.2 (7.4)	60.1 (4.7)	49.6 (5.7)	154
				19	37.7 (7.5)	58.9 (4.8)	48.7 (5.8)	157
1.9CDTi (120PS) estate	121	11.2	8.0	16/17/18	37.7 (7.5)	58.9 (4.8)	48.7 (5.8)	157
				19	37.2 (7.6)	57.6 (4.9)	47.9 (5.9)	159
1.9CDTi 16v (150PS) hatch/saloon	135	8.9	6.2	16/17/18	38.2 (7.4)	60.1 (4.7)	49.6 (5.7)	154
				19	37.7 (7.5)	58.9 (4.8)	48.7 (5.8)	157
1.9CDTi 16v (150PS) estate	130	9.5	6.5	16/17/18	37.7 (7.5)	58.9 (4.8)	48.7 (5.8)	157
				19	37.2 (7.6)	57.6 (4.9)	47.9 (5.9)	159
3.0CDTi V6 24v hatch	143	8.2	5.3	17/18	28.8 (9.8)	54.3 (5.2)	40.9 (6.9)	186
3.0CDTi V6 24v estate	140	8.6	5.6	17/18	28.8 (9.8)	54.3 (5.2)	40.9 (6.9)	186
<b>Automatic transmission</b>								
2.2i 16v Direct hatch/saloon	130	9.5	-	16/17/18	25.0 (11.3)	46.3 (6.1)	35.3 (8.0)	192
				19	24.8 (11.4)	45.6 (6.2)	34.9 (8.1)	194
2.2i 16v Direct estate	129	9.9	-	16/17/18	24.6 (11.5)	44.8 (6.3)	34.4 (8.2)	197
				19	24.4 (11.6)	44.1 (6.4)	34.0 (8.3)	199
2.8i V6 24v Turbo hatch	155	7.2	-	17/18	16.5 (17.1)	38.7 (7.3)	25.9 (10.9)	262
2.8i V6 24v Turbo estate	152	7.4	-	17/18	16.2 (17.4)	37.2 (7.6)	25.2 (11.2)	269
1.9CDTi 16v (150PS) hatch	130	9.4	-	16/17/18	29.7 (9.5)	52.3 (5.4)	40.9 (6.9)	186
				19	29.4 (9.6)	51.4 (5.5)	40.4 (7.0)	189
1.9CDTi 16v (150PS) saloon	130	9.4	-	16/17/18	30.1 (9.4)	53.3 (5.3)	41.5 (6.8)	184
				19	29.7 (9.5)	52.3 (5.4)	40.9 (6.9)	186
1.9CDTi 16v (150PS) estate	129	9.7	-	16/17/18	29.4 (9.6)	51.4 (5.5)	40.4 (7.0)	189
				19	29.1 (9.7)	50.4 (5.6)	39.8 (7.1)	192
3.0CDTi V6 24v hatch	140	8.6	-	17/18	27.7 (10.2)	53.3 (5.3)	39.8 (7.1)	192
3.0CDTi V6 24v estate	137	8.9	-	17/18	27.4 (10.3)	52.3 (5.4)	39.2 (7.2)	194

The fuel consumption figures shown comply with EC directive 1999/100 to provide a realistic indication of fuel consumption by taking into account everyday driving conditions, such as cold starts, acceleration and braking. These figures take account of the vehicle's kerbweight, ascertained in accordance with the above regulation. **Important:** the results given relate to the particular car tested. Variations in trim level and equipment may result in slightly higher fuel consumption and CO<sub>2</sub> emission levels than those quoted. Driving style, road and traffic conditions, vehicle mileage and standard of maintenance may also affect fuel consumption; therefore the results do not express or imply any guarantee of fuel consumption attainable.

### New Signum performance, fuel economy and emissions

	Performance (manufacturer's figures)			Wheel size (inches)	Fuel economy mpg (litres/100km)			CO <sub>2</sub> emissions g/km
	Maximum speed (mph)	Acceleration (sec) 0-60mph	30-50mph (4th gear)		Urban driving	Extra-urban driving	Combined figure	
<b>Manual gearbox</b>								
1.8i 16v VVT	125	10.8	9.6	17/18	27.4 (10.3)	47.9 (5.9)	37.7 (7.5)	180
2.2i 16v Direct	130	9.1	7.5	17/18	25.9 (10.9)	43.5 (6.5)	34.9 (8.1)	194
				19	25.7 (11.0)	42.8 (6.6)	34.4 (8.2)	197
2.0i 16v Turbo	137	8.4	5.9	17/18	22.1 (12.8)	42.8 (6.6)	31.7 (8.9)	214
				19	21.9 (12.9)	42.2 (6.7)	31.4 (9.0)	216
2.8i V6 24v Turbo	151	7.1	5.2	17/18	18.0 (15.7)	37.2 (7.6)	26.6 (10.6)	254
				19	17.9 (15.8)	36.7 (7.7)	26.4 (10.7)	257
1.9CDTi (120PS)	120	11.2	8.1	17/18	37.2 (7.6)	57.6 (4.9)	47.9 (5.9)	159
				19	36.7 (7.7)	56.5 (5.0)	47.1 (6.0)	162
1.9CDTi 16v (150PS)	129	9.5	6.7	17/18	37.2 (7.6)	57.6 (4.9)	47.9 (5.9)	159
				19	36.7 (7.7)	56.5 (5.0)	47.1 (6.0)	162
3.0CDTi V6 24v	139	8.7	5.7	17/18	28.5 (9.9)	53.3 (5.3)	40.4 (7.0)	189
<b>Automatic transmission</b>								
2.2i 16v Direct	128	10.0	-	17/18	24.4 (11.6)	44.1 (6.4)	34.0 (8.3)	199
				19	24.1 (11.7)	43.5 (6.5)	33.6 (8.4)	202
2.8i V6 24v Turbo	150	7.5	-	17/18	16.2 (17.4)	37.2 (7.6)	25.2 (11.2)	269
1.9CDTi 16v (150PS)	127	9.7	-	17/18	29.4 (9.6)	51.4 (5.5)	40.4 (7.0)	189
				19	29.1 (9.7)	50.4 (5.6)	39.8 (7.1)	192
3.0CDTi V6 24v	136	8.9	-	17/18	27.4 (10.3)	52.3 (5.4)	39.2 (7.2)	194

The fuel consumption figures shown comply with EC directive 1999/100 to provide a realistic indication of fuel consumption by taking into account everyday driving conditions, such as cold starts, acceleration and braking. These figures take account of the vehicle's kerbweight, ascertained in accordance with the above regulation. **Important:** the results given relate to the particular car tested. Variations in trim level and equipment may result in slightly higher fuel consumption and CO<sub>2</sub> emission levels than those quoted. Driving style, road and traffic conditions, vehicle mileage and standard of maintenance may also affect fuel consumption; therefore the results do not express or imply any guarantee of fuel consumption attainable.

### Vauxhall Assistance and warranties\*

**Standard features** • A one-year unlimited mileage manufacturer's warranty • Second and third year no-fee customer option warranty up to 60,000 miles (from first registration) • Vauxhall Assistance for 12 months from first registration • Six years' body panel anti-perforation warranty

\* = Warranty is only available on vehicles sourced from Vauxhall Motors Ltd. Terms and conditions apply - please see your Vauxhall retailer for details.

#### Vauxhall Assistance

Vauxhall Assistance is operated by the AA, and is provided automatically with every new Vauxhall for 12 months from first registration. It covers everything from accidents, mechanical breakdown and flat tyres to illness while driving. With Vauxhall Assistance, help is literally just a free\*\* phone call away, 24 hours a day, 365 days a year!

#### Benefits include:

- Full rescue service including roadside assistance
- 'At home' service - help will be sent if there is a vehicle problem at the driver's home

- Recovery - if a problem cannot be solved at the roadside, or if someone is taken ill while driving, the driver, vehicle and all passengers will be transported to the nearest Vauxhall retailer or to any single UK destination
  - Accident assistance - if your vehicle is immobilised by an accident, both the vehicle and occupants will be recovered to your choice of destination (Vauxhall recommends a Vauxhall Approved Accident Repair Centre, where appropriate)
  - Vehicle theft - Vauxhall Assistance will help to keep you mobile in the unlikely event of your vehicle being stolen
- \*\* = Mobile phone users will be charged at their standard tariff.

# DIMENSIONS

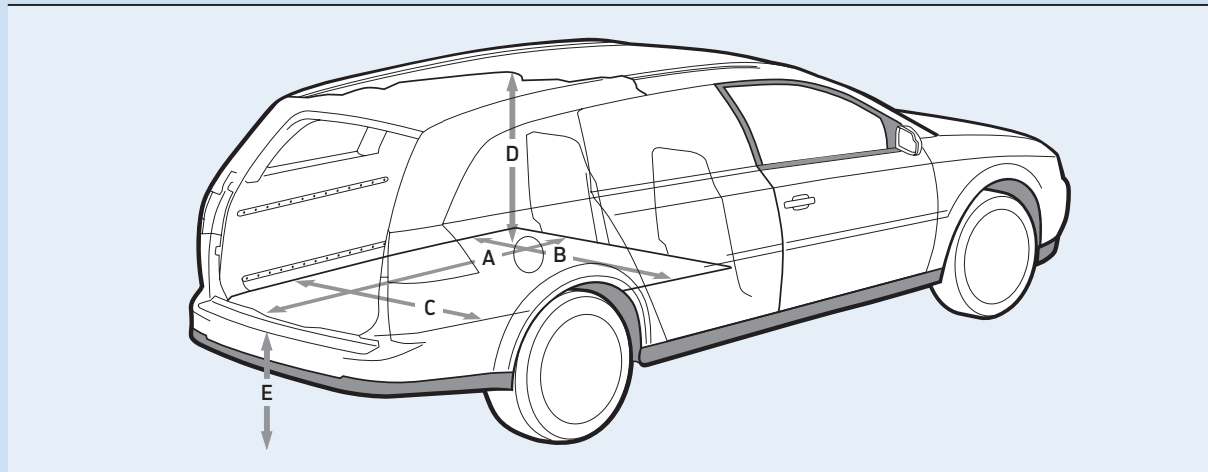

## Loadspace dimensions millimetres (inches)

	New Vectra Estate	New Signum
Maximum load floor length – rear seats folded (A)	2046 (80.6)	1833 (72.2)
Maximum load floor length – rear seats up and fully back	1175 (46.3)	931 (36.7)
Maximum load floor length – rear seats up and fully forward	–	1061 (41.8)
Maximum rear floor width (B)	1079 (42.5)	1054 (41.5)
Minimum rear floor width (C)	1060 (41.7)	978 (38.5)
Maximum load area height (D)	850 (33.5)	761 (30.0)
Loading height from ground level (unladen) (E)	608 (23.9)	599 (23.6)
Maximum tailgate aperture width	1089 (42.9)	1035 (40.7)
Maximum tailgate aperture height	767 (30.2)	727 (28.6)
Maximum load area height beneath luggage compartment cover	472 (18.6)	505 (19.9)

– = This dimension does not apply to this bodystyle.

## Luggage capacities\* litres (cu.ft.)

	Hatchback	New Vectra Saloon	Estate	New Signum
Load volume (minimum) under luggage cover – rear seats up	500 (17.7)	500 (17.7)	530 (18.7)	365 (12.9)
Load volume (maximum) to roof – rear seats folded	1050 (37.1)	1050 (37.1)	1850 (65.3)	1410 (49.8)

\* = Measured using the ECIE method.

## Exterior dimensions millimetres (inches)

### New Vectra

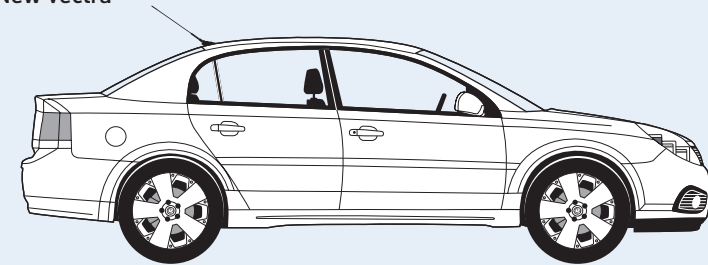

991 (39.0) 2700 (106.3) 920 (36.2)  
4611 (181.5)

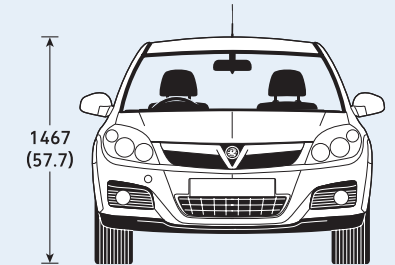

1467 (57.7)  
1798 (70.8) excluding door mirrors  
2036 (80.2) including door mirrors

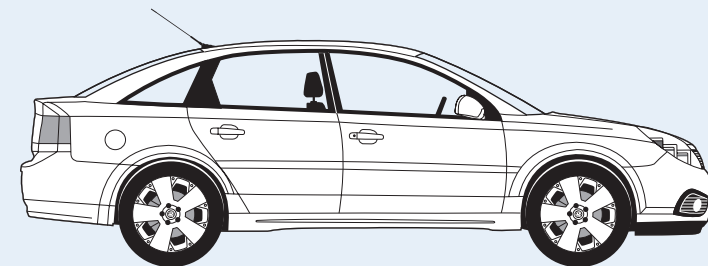

991 (39.0) 2700 (106.3) 920 (36.2)  
4611 (181.5)

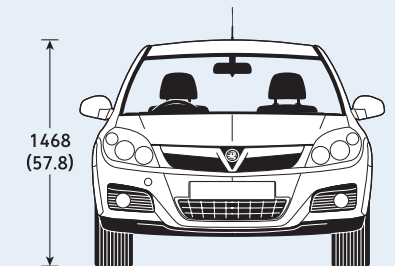

1468 (57.8)  
1798 (70.8) excluding door mirrors  
2036 (80.2) including door mirrors

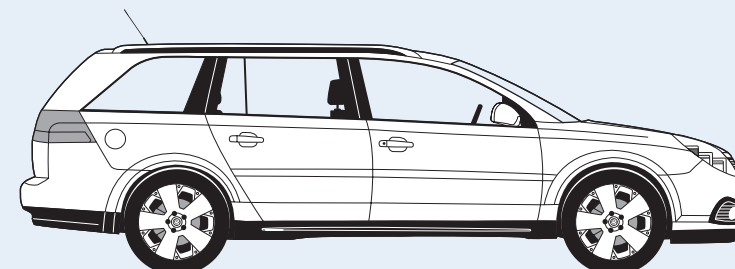

1089 (42.9) 2830 (111.4) 920 (36.2)  
4839 (190.5)

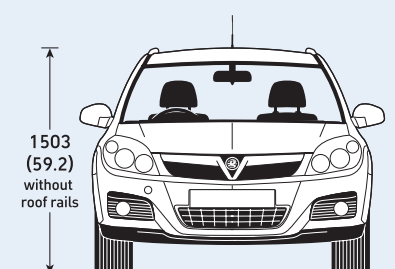

1503 (59.2) without roof rails  
1798 (70.8) excluding door mirrors  
2036 (80.2) including door mirrors

### New Signum

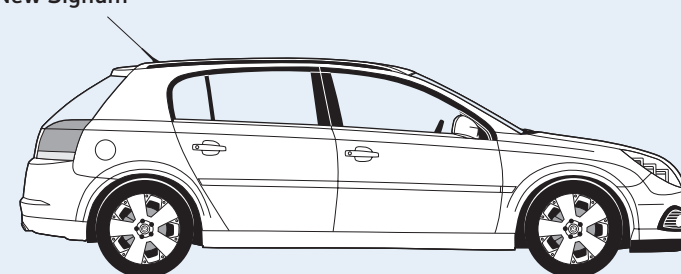

901 (35.5) 2830 (111.4) 920 (36.2)  
4651 (183.1)

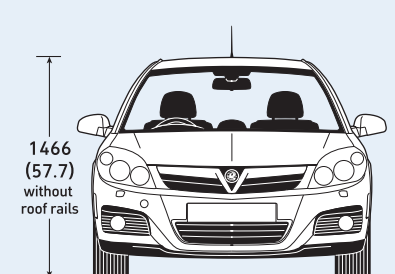

1466 (57.7) without roof rails  
1798 (70.8) excluding door mirrors  
2036 (80.2) including door mirrors



# WEIGHTS AND TOWING

## Weights and towing data (petrol engine models) kg

	Kerbweight (Gross vehicle weight)				Max. towing weights Trailer with brakes (without brakes)		
	Hatchback	Saloon	Estate	Signum	Hatchback/Sal.	Estate	Signum
1.8i 16v VVT Life/Exclusiv	1335 (1885)	1336 (1870)	1400 (2030)	1438 (2020)	1400 (685)	1300 (735)	1400 (740)
1.8i 16v VVT Design	1350 (1885)	1352 (1870)	1431 (2030)	-	1400 (685)	1300 (735)	-
1.8i 16v VVT SRi	1346 (1885)	-	1428 (2030)	-	1300 (685)	1300 (735)	-
1.8i 16v VVT Elegance	-	-	-	1438 (2020)	-	-	1400 (740)
2.2i 16v Direct Design/Elite	1431 (1950)	1416 (1935)	1459 (2085)	-	1500 (715)	1600 (750)	-
2.2i 16v Direct Design/Elite (auto)	1461 (1980)	1446 (1965)	1509 (2115)	-	1600 (715)	1600 (750)	-
2.2i 16v Direct SRi	1428 (1950)	-	1456 (2085)	-	1500 (715)	1600 (750)	-
2.2i 16v Direct SRi (auto)	1455 (1980)	-	1506 (2115)	-	1600 (715)	1600 (750)	-
2.2i 16v Direct Elegance/Exclusiv	-	-	-	1493 (2075)	-	-	1500 (750)
2.2i 16v Direct Elegance/Exclusiv (auto)	-	-	-	1523 (2105)	-	-	1600 (750)
2.2i 16v Direct Design	-	-	-	1494 (2075)	-	-	1500 (750)
2.2i 16v Direct Design (auto)	-	-	-	1524 (2105)	-	-	1600 (750)
2.2i 16v Direct Elite	-	-	-	1499 (2075)	-	-	1500 (750)
2.2i 16v Direct Elite (auto)	-	-	-	1529 (2105)	-	-	1600 (750)
2.0i 16v Turbo SRi	1456 (1995)	-	1523 (2125)	-	1600 (730)	1700 (750)	-
2.0i 16v Turbo Elegance	-	-	-	1518 (2100)	-	-	1700 (750)
2.0i 16v Turbo Design	-	-	-	1519 (2100)	-	-	1700 (750)
2.0i 16v Turbo Elite	-	-	-	1524 (2100)	-	-	1700 (750)
2.8i V6 24v Turbo Elite (auto)	1561 (2080)	-	1594 (2215)	-	1600 (750)	1800 (750)	-
2.8i V6 24v Turbo Design	-	-	-	1594 (2175)	-	-	1700 (750)
2.8i V6 24v Turbo Elite (auto)	-	-	-	1619 (2200)	-	-	1700 (750)

**Gross vehicle weight** is the total permissible weight of the vehicle including passengers and their luggage. To determine total carrying capacity, deduct kerbweight from gross vehicle weight. Note that the figure obtained will include the weight of the driver, passengers and any optional equipment or accessories. The **maximum roof rack loading** should not exceed 100kg. The **maximum towing weights** are based on the ability of the car with two occupants of 70kg each, to restart on a 12% gradient, which is approximately 1 in 8.3, at sea level. At altitudes above 1500 metres, the engine output may drop with a corresponding reduction in towing capability. Any extra weight, such as luggage or additional passengers, should be deducted from the maximum towing weight. With a trailer fully loaded, **maximum noseweight** should not exceed 78kg for Vectra hatchback and saloon and Signum models, or 85kg for Vectra estate models. Always fit Vauxhall towing attachments and accessories available from your Vauxhall retailer. They are designed specifically for Vauxhall models and carry a 12-month guarantee.

## Weights and towing data (diesel engine models) kg

	Kerbweight (Gross vehicle weight)				Max. towing weights Trailer with brakes (without brakes)		
	Hatchback	Saloon	Estate	Signum	Hatchback/Sal.	Estate	Signum
1.9CDTi (120PS) Life/Exclusiv	1428 (1995)	1430 (1980)	1510 (2140)	1548 (2130)	1500 (750)	1500 (750)	1500 (750)
1.9CDTi (120PS) Design	1459 (1995)	1461 (1980)	1541 (2140)	-	1500 (750)	1500 (750)	-
1.9CDTi (120PS) SRi	1456 (1995)	-	1538 (2140)	-	1500 (750)	1500 (750)	-
1.9CDTi (120PS) Elegance	-	-	-	1548 (2130)	-	-	1500 (750)
1.9CDTi (120PS) Design	-	-	-	1549 (2130)	-	-	1500 (750)
1.9CDTi 16v (150PS) Life/Exclusiv	1428 (2005)	1430 (1990)	1525 (2155)	1556 (2145)	1600 (750)	1500 (750)	1500 (750)
1.9CDTi 16v (150PS) Life/Exclusiv (auto)	1473 (2030)	1430 (2015)	1538 (2180)	1581 (1270)	1600 (750)	1500 (750)	1500 (750)
1.9CDTi 16v (150PS) Design/Elite	1459 (2005)	1461 (1990)	1556 (2155)	-	1600 (750)	1500 (750)	-
1.9CDTi 16v (150PS) Design/Elite (auto)	1504 (2030)	1461 (2015)	1569 (2180)	-	1600 (750)	1500 (750)	-
1.9CDTi 16v (150PS) SRi	1456 (2005)	-	1553 (2155)	-	1600 (750)	1500 (750)	-
1.9CDTi 16v (150PS) SRi (auto)	1501 (2030)	-	1566 (2180)	-	1600 (750)	1500 (750)	-
1.9CDTi 16v (150PS) Elegance	-	-	-	1556 (2145)	-	-	1600 (750)
1.9CDTi 16v (150PS) Elegance (auto)	-	-	-	1581 (2170)	-	-	1600 (750)
1.9CDTi 16v (150PS) Design	-	-	-	1557 (2145)	-	-	1600 (750)
1.9CDTi 16v (150PS) Design (auto)	-	-	-	1582 (2170)	-	-	1600 (750)
1.9CDTi 16v (150PS) Elite	-	-	-	1562 (2145)	-	-	1600 (750)
1.9CDTi 16v (150PS) Elite (auto)	-	-	-	1587 (2170)	-	-	1600 (750)
3.0CDTi V6 24v Elite	1596 (2125)	-	1631 (2240)	-	1600 (750)	1800 (750)	-
3.0CDTi V6 24v Elite (auto)	1621 (2150)	-	1656 (2265)	-	1400 (750)	1200 (750)	-
3.0CDTi V6 24v SRi	1593 (2125)	-	1636 (2240)	-	1600 (750)	1800 (750)	-
3.0CDTi V6 24v SRi (auto)	1618 (2150)	-	1661 (2265)	-	1400 (750)	1200 (750)	-
3.0CDTi V6 24v Design	-	-	-	1659 (2240)	-	-	1700 (750)
3.0CDTi V6 24v Design (auto)	-	-	-	1677 (2265)	-	-	1300 (750)
3.0CDTi V6 24v Elite	-	-	-	1664 (2240)	-	-	1700 (750)
3.0CDTi V6 24v Elite (auto)	-	-	-	1682 (2265)	-	-	1300 (750)

**Gross vehicle weight** is the total permissible weight of the vehicle including passengers and their luggage. To determine total carrying capacity, deduct kerbweight from gross vehicle weight. Note that the figure obtained will include the weight of the driver, passengers and any optional equipment or accessories. The **maximum roof rack loading** should not exceed 100kg. The **maximum towing weights** are based on the ability of the car with two occupants of 70kg each, to restart on a 12% gradient, which is approximately 1 in 8.3, at sea level. At altitudes above 1500 metres, the engine output may drop with a corresponding reduction in towing capability. Any extra weight, such as luggage or additional passengers, should be deducted from the maximum towing weight. With a trailer fully loaded, **maximum noseweight** should not exceed 78kg for Vectra hatchback and saloon and Signum models, or 85kg for Vectra estate models. Always fit Vauxhall towing attachments and accessories available from your Vauxhall retailer. They are designed specifically for Vauxhall models and carry a 12-month guarantee.

Stopping distance at 60mph  
Actuating time: 150 milliseconds

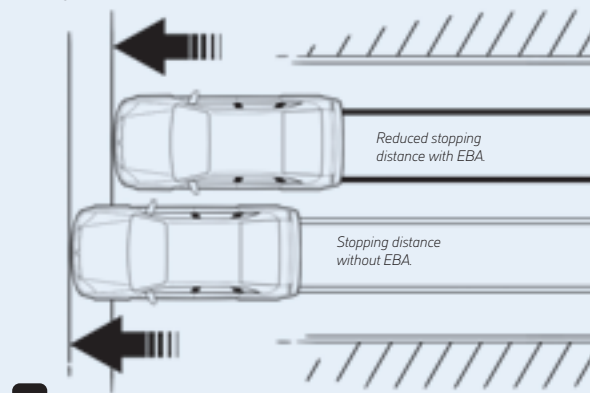

### Emergency Brake Assist (EBA)

**D6.** Emergency brake assist detects the urgency with which the brake pedal is pressed and rapidly increases the pressure to the maximum the system can provide, shortening stopping distances. It also enhances pedal feel.

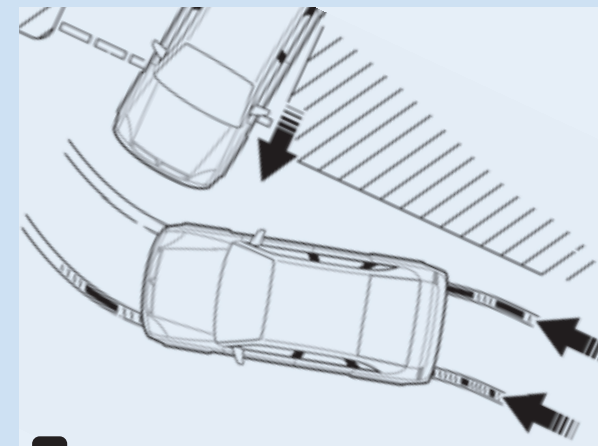

### Anti-lock Braking System (ABS) with Cornering Brake Control (CBC)

**D7.** Cornering brake control makes the car easier to control in extreme situations, particularly when braking sharply on a bend. It is particularly effective when carrying out emergency procedures, such as avoiding a child's ball that's rolled out from the kerb. The system works by sensing the different rotational speeds of the individual road wheels and co-ordinating the level of braking pressure applied to each wheel. CBC is an integral part of New Vectra and New Signum's comprehensive ABS.

# VAUXHALL BY DESIGN

Styling and accessories

## VXR exterior styling (Vectra only)

- VXR Styling pack one<sup>1</sup>
- Front lower spoiler (hatch/saloon/estate)
- Rear lower skirt<sup>1</sup>
- Side sills (hatch/saloon/estate)
- Rear roof spoiler (estate)
- Rear lip spoiler (hatch/saloon)

<sup>1</sup> = Only suitable for SRi models. Not available with optional parking distance sensors on estate models.

## Irmscher exterior styling

- Front lower spoiler
- Cross hatch grilles
- Rear lip/wing/roof spoilers
- Rear lower skirt (for use with sports silencer)
- Side sills
- Rear bumper sports insert (SRi)
- Protection trim for rear bumper (estate)
- Chrome-effect door mirror covers
- Stainless steel door handle covers
- Door handle spoilers
- Side pillar trim kit
- Irmscher Styling packs

## Irmscher interior styling

- Velour floor mats with 'Irmscher' logo
- Door lock buttons
- Aluminium pedals (manual)
- Stainless steel interior door sill covers
- Handbrake levers
- Three-spoke steering wheel – leather/matt chrome-effect

## Irmscher alloy wheels

- Softstar – 16/17-inch
- Twin Spoke – 17-inch
- Spectra Sports Line – 17-inch
- Signa – 16/18-inch
- Sport Star – 16/17/18-inch
- Delta – 17/19-inch<sup>2</sup>
- Stila – 16/18-inch
- Stila-polished – 18-inch
- Evo Star – 18/20-inch<sup>2</sup>
- GT Star – 19-inch<sup>2</sup>
- Evo Star Titanium – 18-inch
- GT Star Titanium – 19-inch<sup>2</sup>

<sup>2</sup> = Wheel arch modifications may be necessary.

## Irmscher sports silencers

- Sports silencer with twin rectangular stainless steel tailpipes
- Sports silencer with dual branched twin rectangular stainless steel tailpipes

## Irmscher suspension kit<sup>3</sup>

- Uprated and lowered spring and suspension kits

<sup>3</sup> = Not for use with towing equipment.

## Child seats<sup>4</sup>

- Vauxhall BABY-SAFE – birth to 13kg
- Vauxhall DUO ISOFIX – 9 to 18kg
- Vauxhall KID – 15 to 36kg
- Baby mirror

<sup>4</sup> = Restrictions apply regarding the fitment and positioning of child seats. Please consult your Vauxhall retailer for further details.

## Safety

- First aid kit
- Warning triangle
- Fire extinguisher – 1 or 2kg
- Temporary tyre repair kit

## Security

- Locking wheel bolts
- Steering wheel security bar

## Practical

- Spare bulb kit (not for AFL or xenon headlights)
- Jump leads – standard or heavy duty
- Fuel can – 5 or 10 litres
- Stretch tow rope – 2 tonne rated

## Exterior

- Mudflaps
- Rear parking distance sensor
- Headlight protectors
- Door wind deflectors (front pair)

## Interior – cabin area

- Floor mats
- Front passenger's storage box
- Rear seat protection cover
- Sunblind – rear window (hatchback)
- Storage bag including rucksack
- Waste bag

## Interior – load area

- Loading protection for rear bumper
- Anti-slip mat
- Bootliner (Vectra only)
- Cargo liner
- Dog guard (estate)<sup>5</sup>
- Space divider grid (for use with dog guard on estate)
- Load-restraining floor net
- Vertical load-restraining net (estate)<sup>6</sup>
- Load-restraining storage net
- Electrically chilled 12-litre cool bag
- Parcel shelf storage bag (hatchback)
- Boot storage box (hatchback/saloon)

<sup>5</sup> = Requires accessory fitting kit if vehicle is not equipped with a factory-fit vertical load restraining net option.

<sup>6</sup> = Requires additional fitting kit.

## FlexOrganiser® (estate)

- 3D storage net
- Side net pocket
- Side rail hooks
- Vertical divider mesh
- Side rail strap
- Fold-flat storage box
- 2-in-1 carry case
- Divider rods
- Hooks for divider rods

## Load carriers

### Roof carrier system

- T-track base carrier
- Bicycle carriers
- Luggage restraining strap
- Ski/snowboard carrier
- Extendable ski carrier
- Sport roof boxes
- Travel roof box
- Surfboard/windsurf board carrier

### Interior carrier system

- Bicycle carrier (estate)

## Tow bar carrier system

- Tow bar mounted bicycle carrier (two bicycles)
- Extension for third bicycle

## Towing

- Fixed tow bar with electrics
- Detachable tow bar with electrics
- Bumper cut-out cover (for use with detachable tow bar)
- Towing mirrors
- Electrical adaptor (for use with optional towing packs)

## Audio, navigation and accessories

- Satellite navigation/stereo radio/CD player systems
- Roof-mounted removable DVD player (Vectra estate only)
- Portable CD storage bag
- Sunvisor CD storage
- Single DIN fascia kit

## Communications

- Hands-free Bluetooth® mobile phone cradle – suitable for many specific handsets<sup>7</sup>

<sup>7</sup> = Only suitable for vehicles fitted with the factory-fit Bluetooth® system.

# TRUST VAUXHALL

There are more important things to life than worrying about how to finance and service your car, where to go in the event of an accident and how we go about meeting the transport challenges of the future. So when you choose Vauxhall, you can rely on us to safeguard both you and the environment around you, leaving you free to concentrate on the more important business of enjoying your car!

## Protecting the environment

At Vauxhall, we take a broader viewpoint than the design, manufacture and selling of cars. We are committed to looking after the environment throughout the life cycle of the vehicle.

Our products are increasingly winning environmental awards, both through the use of more recycled materials and by becoming cleaner and more efficient. For information on Vauxhall's efforts to achieve an environmentally sustainable future, including information on Design for Recycling, take-back of End-of-Life Vehicles (ELVs), and the recycling of ELVs, see [www.vauxhall.co.uk/recycling](http://www.vauxhall.co.uk/recycling).

Looking to the future, we are also investing heavily in the biggest potential breakthrough of the next decade – the hydrogen fuel cell car.

## Customer Care Commitment

Providing drivers with the highest standards of aftersales support, Vauxhall offers a three-year Customer Care Commitment\* package. Highlights include:

- A one-year unlimited mileage manufacturer's warranty
- A second and third year no-fee customer option warranty to 60,000 miles from first registration
- Vauxhall Assistance for 12 months from first registration
- Six years anti-perforation warranty

\* = Warranty is only available on vehicles sourced from Vauxhall Motors Ltd. Terms and conditions apply – please see your Vauxhall retailer for details.

## Servicing and maintenance

The best way to maximise the performance and reliability of your Vauxhall is to have all routine servicing and maintenance carried out at a Vauxhall retailer. There are around 400 retailers nationwide.

## Vauxhall Assistance

Vauxhall Assistance is operated by the AA and is provided for 12 months from date of first registration and covers everything from accidents, mechanical breakdown and flat tyres to illness while driving. With Vauxhall Assistance, help is literally just a free\*\* phone call away, 24 hours a day, 365 days a year!

\*\* = Mobile phone users will be charged at their standard tariff.

## Vauxhall Leasing

As Vauxhall's own contract hire and fleet management operation, Vauxhall Leasing provides a one-stop-shop for competitive car and van leasing solutions – for business users and private individuals. Working with the Vauxhall retailer network, we combine the support of a national contract with the convenience of a local contact. For further information, please see your local Vauxhall retailer or call us on 0870 737 2557. Alternatively, visit our website at [www.vauxhall-leasing.co.uk](http://www.vauxhall-leasing.co.uk)

## Buying your car

For straightforward advice on a simple, affordable way into a new or used car ask your Vauxhall retailer. GMAC offers a wide range of finance solutions that are easy to understand, flexible enough to suit every need and convenient to arrange at your Vauxhall retailer.

## In the event of an accident...

Vauxhall Accident Support is designed to help keep you mobile following an accident, providing prompt recovery to a Vauxhall Approved Accident Repair Centre where your vehicle can be repaired to a high standard. The service is free to all Vauxhall drivers. For further information Freefone 0800 010 304.

## Sureguard protection

Should you wish to enjoy the range of benefits provided by Vauxhall Assistance for a full three years from first registration, then new Sureguard Assistance is for you. If you are a higher mileage driver or plan to keep your vehicle for longer than the standard warranty period, you need the protection of Sureguard Warranty. This provides all the peace of mind of a parts and labour warranty – including Assistance – for the duration of your cover. Sureguard Warranty and Sureguard Assistance now come with the added peace of mind of Sureguard MOT Warranty. For details contact your local Vauxhall retailer or call 0870 752 7020.

## Specialist Mobility advice

Motability accredited Vauxhall retailers can provide special mobility help and advice. Blue badge holders are entitled to very favourable discounts when purchasing new vehicles. For full details contact your local Motability accredited Vauxhall retailer or Freefone 0800 731 5267.



## USEFUL CONTACTS

- Vauxhall Mobility
- Vauxhall Military/Diplomatic Sales
- Vauxhall Rental
- Fleet Support
- Vauxhall Accident Support
- Sureguard extended warranty
- Vauxhall Insurance
- Vauxhall Leasing

0800 731 5267  
0870 442 1580  
0870 442 1567  
0870 010 0651  
0800 010 304  
0870 752 7020  
0870 024 0240  
0870 737 2557

## For more information...

For a brochure on any Vauxhall model (up to a maximum of three per caller) or location of your nearest Vauxhall retailer please **Lo-call 0845 600 1500**.

Alternatively, details can be found on our website at **[www.vauxhall.co.uk](http://www.vauxhall.co.uk)**



For more details on the accessory range pick up the latest Car and Accessory Price Guide or visit: [www.vauxhall.co.uk/accessories](http://www.vauxhall.co.uk/accessories)

