



Want to save up to £2000\* on a new Vauxhall?



You want  
this  
card



Apply for The GM Platinum Card today

- ✦ 100 Rebate Points when you use your GM Card for the first time - worth £100 off a new Vauxhall
- ✦ 3% of the value of your GM Card purchases as Rebate Points
- ✦ 0% p. a. on purchases and balance transfers fixed for the first five months from account opening
- ✦ Typical **14.9% APR** variable

Call **0845 746 2777** and quote **REF:AGM1** or apply online at **www.gmcard.co.uk/brochure**

The GM Platinum Card is issued by HFC Bank Limited and is available to persons aged 18 years or over and resident in the UK (or 21 and over in the Channel Islands) and is subject to status and conditions. Written quotations are available upon request from The GM Platinum Card, PO Box 3615, Birmingham B3 2RJ. The typical APR quoted is the rate for new customers. \*Rebate Points are earned on purchases using The GM Platinum Card. Rebate Points are not earned on Balance Transfers or Cash Advances. You earn money off a new Vauxhall/Saab by accumulating Rebate Points under the Rebate Points Programme. Vauxhall Motors Ltd is solely responsible for the operation of the Rebate Points Programme, which is subject to the Rebate Points Programme Rules. You can redeem up to 2500 Rebate Points and unlimited Partner Points subject to the Model Line Maximum which will vary in amount in relation to different Vauxhall/Saab vehicle model lines. Rebate Points and unlimited Partner Points are redeemable as discounts on a new Vauxhall/Saab vehicle and must be redeemed four years from the issue date. Rebate Points may not be redeemed by Motability Contract Hire customers. The GM Card is a trading name and style of both HFC Bank Limited and Vauxhall Motors Ltd. HFC Bank registered in England No. 1117305. Registered Office: North Street, Winkfield, Windsor, Berkshire SL4 4TD is authorised and regulated by the Financial Services Authority. Member HSBC Group. HFC Bank Limited is not a member of the same group of companies as Vauxhall Motors Ltd, Saab GB Limited or GMAC. Vauxhall Motors Ltd, Registered Office: Griffin House, Osborne Road, Luton, Bedfordshire LU1 3YT. Registered in England number 135767.



Contents	
Equipment	S.2-S.5
Audio, communications and navigation	S.6
Technical data	S.8-S.11
Dimensions and weights	S.12
Vauxhall by Design	S.14
Customer care	S.15

## New Zafira Specifications



You could  
dodge high  
premiums.



Call now to get a quote.

**0870 024 0240**

Lines open 8am-8pm Monday to Friday, 9am-5pm Saturday. Calls may be recorded.

**www.vauxhall.co.uk/insurance**

Vauxhall Motor Insurance is underwritten by UK Insurance Limited. Conditions apply. Calls may be recorded.



Every effort has been made to ensure that the contents of this publication were accurate and up-to-date at the time of going to press (February 2006). Vauxhall vehicles are equipped with components manufactured by various General Motors operating units and outside suppliers. The Company reserves the right to alter specifications and withdraw products from sale without notice. Any such alterations will be notified to Vauxhall retailers at the earliest opportunity, please consult your local retailer for the latest information. The specifications detailed within this brochure are not necessarily applicable to alternative models such as Special Editions. Details of any such models will be contained in specific literature or found on the Vauxhall website. Please note that Vauxhall retailers are not the agents of Vauxhall Motors Limited and are not authorised to bind the Company by any specific or implied undertaking or representation. It is advisable to ensure that your motor insurance policy provides adequate cover for additional fitted options and accessories. As part of Vauxhall's policy of environmental care, this brochure is printed on paper manufactured using Elemental Chlorine Free pulps from specially farmed, sustainable timber resources. All rights reserved. No part of this publication may be reproduced in any form or by any means, without the prior written permission of Vauxhall Motors Limited.

Published February 2006 (Graymatter) Amended April 2006 Vauxhall Motors Limited, Luton LU1 3YT www.vauxhall.co.uk

VM0506140



# EQUIPMENT



Aluminium pedals.



Second-row centre armrest.



Front centre console drinks holder.

## Vauxhall Assistance and warranties\*

**Standard features** • A one-year unlimited mileage manufacturer's warranty • Second and third year no-fee customer option warranty up to 60,000 miles (from first registration) • Vauxhall Assistance for 12 months from first registration • Roadside breakdown cover in years two and three (subject to vehicle being serviced at a Vauxhall retailer) • Six years' body panel anti-perforation warranty

## Safety

**Standard features** • Anti-lock Braking System (ABS) • Electronic Brakeforce Distribution (EBD) • Cornering Brake Control (CBC) – see **D12** on page S.11 • Pyrotechnic front body-lock seatbelt pretensioner system – Tightens the seatbelt during the early stages of a frontal impact • Front seatbelt force limiters – Reduce the loading on the occupants' chests by releasing the belts very slightly, if the force exceeds a specified limit, in a frontal impact • Emergency Brake Assist (EBA) – see **D13** on page S.11 • Pedal release system – Reduces potential injury to the driver's legs and feet during a severe frontal impact • ISOFIX child seat restraint system for outer second-row seats (does not include child seat) – Secures ISOFIX child safety seats to the vehicle itself, virtually eliminating the dangers that can result from improper installation • Driver's and front passenger's airbags • Front seat side-impact airbags • Inertia-reel lap and diagonal seatbelts on all seats • Height-adjustable head restraints on all seats • Laminated windscreen • Side-impact protection beams • Energy-absorbing steering column • Child-proof locks on rear doors • Adaptive Brake Lights (ABL) – If the driver brakes hard enough to activate the ABS the brake lights flash on and off at the rate of four times per second, thus warning following vehicles that heavy braking is in progress

Additional features	Express.	Life	Club	Design	SRi
Electronic Stability Programme-plus (ESP-plus) <b>D1</b> with traction control		○ <sup>1</sup>	○ <sup>1</sup>	○ <sup>2</sup>	●
Full-size curtain airbags (front and second-row seating)	○	○	●	●	●
Tyre deflation detection system <b>D2</b>		□	□	□	
Hill Start Assist (HSA) <b>D5</b> – see page S.5		□ <sup>3</sup>	□ <sup>3</sup>	□ <sup>3</sup>	

## Security

**Standard features** • Remote control central deadlocking (doors, tailgate and fuel flap) • 'Key left in ignition' audible warning • Electronic engine deadlock immobiliser • Locking wheel bolts for alloy wheels (where fitted) • Electronic theft protection for audio equipment

Additional features	Express.	Life	Club	Design	SRi
Folding key			●	●	●
Keyless entry and start ignition system		○ <sup>4</sup>	○	○	○
Remote control ultrasonic security alarm system		○ <sup>4</sup>	○	○	●

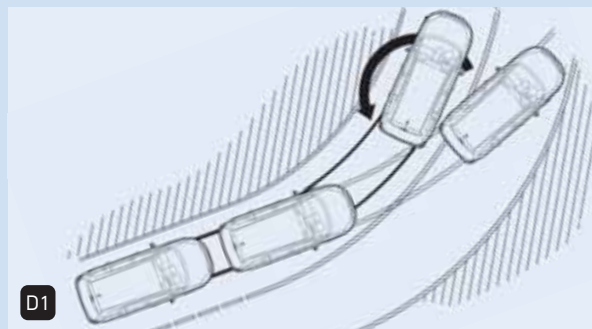

### Electronic Stability Programme-plus (ESP-plus)

**D1.** ESP-plus provides enhanced yaw compensation during understeer or oversteer. The system works by monitoring the front and rear of the car, comparing their respective directions of travel going in to the bend with the input received through the steering wheel. If the vehicle starts to slide, it applies corrective braking to the appropriate wheel, or wheels, compensating for the slide and helping you regain control more rapidly.

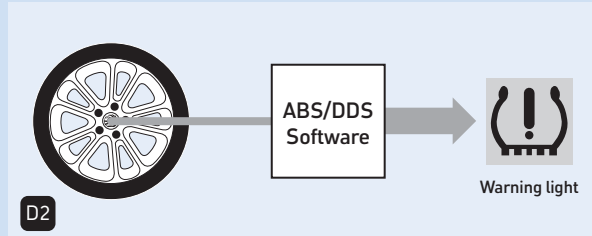

### Tyre deflation detection system

**D2.** The deflation detection system works without specific sensors, identifying pressure loss through changes in the rolling radius of the tyres by using the car's ABS sensors to measure changes in wheel speed brought on by a sudden reduction in tyre size. A warning light illuminates in the event of rapid tyre deflation. Available as part of the Towing pack.

## Seating and upholstery

**Standard features** • Flex7 seating system • Reclining front seats • Driver's seat height adjuster • 40/20/40 split-folding second-row seat back • Second-row seats with sliding function plus fold and stow facility • Multi-function fold-down second-row centre seat with drinks holders and fold-out centre armrest • Two individual fold-flat third-row seats • Carpeted passenger compartment, load area floor and rear seat backs

Additional features	Express.	Life	Club	Design	SRi
Sports front seats			□	●	●
Leather seat facings			□	□	□
Driver's seat with tilt and lumbar adjustment			□	●	●
Driver's armrest			□	●	●
Heated front seats			□	□	□

## Facia, instruments and controls

**Standard features** • Steering column adjustable for reach and rake • Rev counter • Electronic odometer and trip odometer • Service-due indicator • Multi-function display panel incorporating digital clock, outside air temperature (with ice warning symbol), date and audio information • Electrical accessory socket • 'Drive by wire' electronic throttle

Additional features	Express.	Life	Club	Design	SRi
Multi-function trip computer				●	●
Black instrument dials	●	●	●	●	
Black instrument dials with chrome edging					●
Three-spoke steering wheel	●	●	●		
Leather-covered three-spoke steering wheel				●	
Leather-covered three-spoke sports steering wheel					●
Cruise control		□	□	□	□

## Interior features

**Standard features** • Air blend heater with four-speed fan and illuminated controls • Interior pollen filter • Air recirculation system with activation light • Second-row passenger compartment heating outlets • Drinks holder in centre console • Front and rear door pockets with drinks holders • Front sill storage bins • Drinks holders in third-row seat side armrests • Retractable luggage compartment cover • Latched storage lockers in luggage compartment

Additional features	Express.	Life	Club	Design	SRi
Air-conditioning		● <sup>5</sup>	● <sup>5</sup>	●	●
Electronic Climate Control (ECC) with air quality sensor and graphic display		□	□	□	□
Matt chrome-effect centre console insert					●
Microtech Silver inserts on facia and doors			●	●	
Maze chrome-effect inserts on facia and doors					●
Charcoal metallic-effect inserts on facia and doors	●	●			
Aluminium pedals					●
Brushed aluminium door sill covers				●	●
Electro-chromatic anti-dazzle rear-view mirror				●	
Driver's sunglasses holder				●	●
12-volt auxiliary power socket located in luggage compartment		●	●	●	●
Front passenger's underseat storage tray <sup>6</sup>			●	●	●

● = Standard equipment.  
○ = Optional at extra cost.  
□ = Only available as part of an extra-cost option pack (see page S.5 for details).  
Express. = Expression.  
\* = Warranty is only available on vehicles sourced from Vauxhall Motors Ltd. Terms and conditions apply – please see your Vauxhall retailer for details.

1 = Standard on 2.2i 16v Direct model.  
2 = Standard on 2.2i 16v Direct/2.0i 16v Turbo/1.9CDTi 16v (150PS) models only.  
3 = Also available as an individual option on models fitted with Easytronic gearbox. Only available with ESP-plus.

4 = Includes map reading light, sunvisors with illuminated vanity mirrors and rear reading lights.  
5 = Optional at extra cost on 1.6i 16v models.  
6 = Deleted when Leather pack or keyless entry and start options are specified.

# EQUIPMENT



17-inch ten-spoke alloy wheels.



Front fog lights.



Panoramic roof.

## Mechanical

Features	Express.	Life	Club	Design	SRI
Five-speed manual gearbox (1.6i 16v/1.8i 16v VVT)	●	●	●	●	●
Six-speed manual gearbox (2.2i 16v/2.0i 16v Turbo/1.9CDTi (120/150PS))		●	●	●	●
Five-speed Easytronic gearbox (1.8i 16v VVT)		○	○	○	
Four-speed automatic transmission (2.2i 16v)		○	○	○	○
Six-speed automatic transmission (1.9CDTi (120/150PS))		○	○	○	○
Interactive Driving System-plus (IDS-plus) with Continuous Damping Control (CDC)					○
Sports suspension				● <sup>2</sup>	●
Sport switch – see <b>D14</b> on page S.11				● <sup>2</sup>	●

## Exterior features

**Standard features** • Green-tinted glass • Electrically operated front windows with safety autoreverse and one-touch facility • Intermittent rear window wash/wipe • Electrically adjustable door mirrors • Electric headlight beam levelling • H7 halogen headlights • Body-colour door mirrors

Additional features	Express.	Life	Club	Design	SRI
Rain-sensitive windscreen wipers				●	
Automatic Lighting Control (ALC)				●	
Dark-tinted glass (excludes windscreen and front door windows)				●	●
Electrically operated rear windows with safety autoreverse and child isolation facility				●	●
Chrome exhaust tailpipe (2.0i 16v Turbo only)					●
Black roof rails		●	●		
Alloy-effect roof rails			□	●	●
Front fog lights				●	●
Two-coat metallic or pearlescent paint	○	○	○	○	○
Electrically heated door mirrors			●	●	●
Two-tone horn				●	●
Body-colour door handles and tailgate handle			●	●	●
Black side-protection mouldings	●	●			
Body-colour side-protection mouldings			●	●	●
Adaptive Forward Lighting (AFL) incorporating bi-xenon headlights with dynamic beam levelling and high-pressure washers <b>D3</b> <b>D4</b>			○ <sup>7</sup>	○	○
High-pressure headlight washers		□	□	□	□
Front and rear parking distance sensors		○	○	○	○
Heat-reflective windscreen			□	□	□



D3

### Adaptive Forward Lighting (AFL)

Adaptive Forward Lighting is a sophisticated new lighting system that allows drivers to see around corners. This optional bi-xenon system employs two main functions:

#### Curving Light

**D3.** Controlled by a combination of steering wheel movement and sensors for the vehicle's speed and yaw angle, the Curving Light function allows the headlight beam to move up to 15 degrees left or right of the straight ahead position. This ensures the light is always following the trajectory plotted by the front wheels, rather than simply pointing straight ahead.

#### Motorway Light

**D4.** At speeds above 65mph, AFL raises the dipped headlight beam to extend the range of vision for increased safety at higher speed. The beam automatically returns to its normal position when the car falls below that speed. New Zafira is one of the first cars in its class to offer such technology.



D4

## Wheels and tyres

Features	Express.	Life	Club	Design	SRI
16-inch steel wheels with flush covers and 205/55 R 16 ultra-low profile tyres	●	●			
16-inch ten-spoke alloy wheels with 205/55 R 16 ultra-low profile tyres and locking bolts			●		
16-inch five-spoke alloy wheels with 205/55 R 16 ultra-low profile tyres and locking bolts (1.8i 16v VVT/1.9CDTi (120PS))				●	
17-inch ten-spoke alloy wheels with 225/45 R 17 ultra-low profile tyres and locking bolts (2.2i 16v Direct/2.0i 16v Turbo/1.9CDTi 16v (150PS))				●	
17-inch five-spoke alloy wheels with 225/45 R 17 ultra-low profile tyres and locking bolts					●
18-inch five-spoke alloy wheels with 225/40 R 18 ultra-low profile tyres and locking bolts <sup>8</sup>					○ <sup>9,10</sup>
Steel spare wheel	●	●	●	● <sup>8</sup>	● <sup>8</sup>
Emergency tyre repair kit (in lieu of spare wheel)	N/C	N/C	N/C	N/C <sup>8</sup>	N/C <sup>8</sup>

## Option packs

	Express.	Life	Club	Design	SRI
<b>Leather pack</b> • Leather seat facings • Electrically heated sports front seats with tilt and lumbar adjustment • Front passenger's seat height adjuster			○ <sup>11</sup>	○	○
<b>Panoramic roof pack</b> <sup>12</sup> • Four glass roof panels • Roof-mounted storage console for front and rear passengers • Alloy-effect roof rails • Heat-reflective windscreen			○ <sup>13</sup>	○ <sup>13</sup>	○
<b>Towing pack</b> <sup>14</sup> • Trailer Stability Programme (TSP) • Hill Start Assist (HSA) • Automatic self-levelling rear suspension • Tyre deflation detection system • Cruise control • Detachable tow bar		○	○	○ <sup>15</sup>	
<b>Technical pack</b> • Electronic Climate Control (ECC) • Cruise control		○ <sup>16</sup>	○ <sup>16</sup>	○	○
<b>Smoker pack</b> • Front cigar lighter and second-row electrical accessory socket • Front and second-row ashtrays		○	○	○	○
<b>VXR Styling pack one</b> • Body-colour lower front spoiler/rear lower skirt/rear roof spoiler and side sills (not available with CDC 40 DAB audio unit)			○	○	○ <sup>9</sup>
<b>FlexOrganiser® pack</b> • 3D storage net • Side net pocket • Four side rail hooks • Four side rails • Load area sill protection (Life)		○	○	○	○

● = Standard equipment.  
○ = Optional at extra cost.  
N/C = No-cost option.  
□ = Only available as part of an extra-cost option pack.  
Express. = Expression.

2 = Standard on 2.2i 16v Direct/2.0i 16v Turbo/1.9CDTi 16v (150PS) models only.  
7 = AFL includes front fog lights on Club models.  
8 = On 2.0i 16v Turbo models and models fitted with optional 18-inch alloy wheels the steel spare wheel is replaced by an emergency tyre repair kit.  
9 = Standard on SRI with Exterior pack models. SRI with Exterior pack models feature VXR Styling pack one and 18-inch five-spoke alloy wheels with 225/40 R 18 ultra-low profile tyres. Please see the latest Vauxhall Car and Accessory Price Guide for availability details.  
10 = Not available on 1.9CDTi 16v (150PS) automatic model with Panoramic roof pack.  
11 = Includes driver's armrest and leather-covered steering wheel.

12 = Not available on 1.9CDTi 16v (150PS) automatic SRI with Exterior pack models or in conjunction with 18-inch alloy wheels on 1.9CDTi 16v (150PS) automatic SRI models. Not available with Glacier White exterior paint.  
13 = Only available in conjunction with Electronic Stability Programme-plus.  
14 = Only available in conjunction with Electronic Stability Programme-plus. Requires 13-pin adaptor (available as a Vauxhall accessory). When Towing pack is supplied in conjunction with automatic transmission the tyre deflation detection system and HSA are deleted.  
15 = Automatic self-levelling rear suspension is deleted on 2.2i 16v, 2.0i 16v Turbo and 1.9CDTi 16v (150PS) models.  
16 = Only available on models fitted with air-conditioning.



D5

### Hill Start Assist

**D5.** Hill Start Assist maintains the brake pressure for 1.5 seconds after the brake pedal has been released when pulling away or parking on a slope; this helps prevent the vehicle from rolling back should the driver release the brake pedal before first applying the handbrake. The pressure is released as soon as the driver presses the accelerator and the car begins to move forward.



# AUDIO, COMMUNICATIONS AND NAVIGATION



Steering wheel mounted audio controls.



Twin Audio® system.



CD 70 satellite navigation.

## Audio and communications availability

**Standard features** • Radio data system (RDS EON) with Traffic Programme • Remote audio display • Roof-mounted flexible aerial • Dimmable illumination • FM and MW reception • Microprocessor-controlled quartz tuning • Autostore function

Additional features	Express.	Life	Club	Design	SRI
CC 20 stereo radio/cassette player/two speakers (20 watts per channel)	●				
CD 30 stereo radio/CD player/six speakers (17 watts per channel)		●	●	●	●
CD 30 MP3 stereo radio/CD with MP3 capability <b>D8</b> /multi-function display/seven speakers (20 watts per channel)		○	○	○	○
CDC 40 stereo radio/integral six-disc CD autochanger/graphic display/seven-band graphic equaliser/seven speakers (35 watts per channel)			○ <sup>17</sup>	○ <sup>17</sup>	○ <sup>18</sup>
CDC 40 stereo radio with Digital Audio Broadcast (DAB) <b>D6</b> /integral six-disc CD autochanger/graphic display/seven-band graphic equaliser/seven speakers (35 watts per channel)		○	○ <sup>19</sup>	○ <sup>19</sup>	
CD 70 stereo radio/CD with MP3 capability <b>D8</b> /satellite navigation <b>D11</b> with colour monitor/seven speakers (20 watts per channel)		○ <sup>4</sup>	○	○	○
Roof-mounted removable DVD player (retailer-fit) <sup>20</sup> <b>D7</b>		○	○	○	○
Twin Audio® system (only available with optional audio units) <b>D10</b>		○	○	○	○
Mobile phone system with Bluetooth® (does not include phone or cradle) <b>D9</b>		○ <sup>4</sup>	○	○	○
Steering wheel mounted audio controls			●	●	●

● = Standard equipment.  
○ = Optional at extra cost.  
Express. = Expression

4 = Includes map reading light, sunvisors with illuminated vanity mirrors and rear reading lights.  
17 = Only available in conjunction with VXR Styling pack one.  
18 = Only available on SRI with Exterior pack models.

19 = Not available in conjunction with VXR Styling pack one.  
20 = Not available in conjunction with Panoramic roof pack.



### Digital Audio Broadcast (DAB)

**D6.** Now widely available in the UK, digital audio broadcasts offer the user a variety of advantages over traditional FM, starting with the digital quality sound which is immune to any hiss or crackle. You'll often find a broader range of stations on offer too, many of which are not available on FM, and listening to them couldn't be easier – you simply select the station, by name, from the displayed list, thus removing the need to retune or look for stations when travelling around. Some stations will even display the artists' names and song titles on the car's graphic display, while they're played.

To further help you appreciate the digital sound, our CDC 40 DAB-compatible audio unit offers 35 watts per channel and plays through our highest quality seven-speaker system.

**D6**

### Roof-mounted removable DVD player

**D7.** The DVD player available for New Zafira features a 7-inch screen with excellent picture quality and brightness – very important features for in-car use. Mounted in the roof of the vehicle, it's ideally situated to allow good visibility for all five passengers in the second and third rows.

Not only that but it is also removable from the vehicle, offering the advantages of extra security and the ability to continue watching films after the journey has ended – it can even be connected up to a TV if required.

Included within the DVD player package are two sets of wireless headphones with carry cases, a remote control and a mains electricity adaptor.

**D7**

### MP3 CD player

**D8.** An MP3 is a compressed sound or music file which, due to its small size, takes up less space on a compact disc, which means that more tracks can be recorded onto a CD. It's possible to fit almost 10 hours of music onto one CD, and, in a way, turns a single-disc CD/MP3 player into a multi-disc autochanger.

Providing you have access to a compatible computer to create the MP3 tracks, you can compress your CD collection and create your own compilations – and you won't have to drive around with all your original CDs in the car.

**D8**

### Mobile phone system

**D9.** Vauxhall's optional factory-fit dual-band mobile phone system has been considerably enhanced for New Zafira. Now fully integrated into the audio and communication system, it also features voice control and will connect wirelessly to phones featuring Bluetooth® technology.

One advantage of the system is its intuitive operation. Configuring a Bluetooth® phone to work with Vauxhall's mobile phone system takes mere seconds so, as soon as a connection is achieved, features such as the phonebook are automatically displayed on New Zafira's graphic display screen and navigated via either the steering wheel mounted controls or the multi-function button on the radio. Making and receiving calls is easy, especially as the voice activation feature means that your concentration on the road won't be affected.

Mounted on the centre console, the phone system base unit can be fitted with cradles (available as accessories) for many different mobile phones. The cradle acts both as a place to store your phone while driving and as a charger. Contact your Vauxhall retailer for information regarding compatible mobile phones, or refer to the Car and Accessory Price Guide for a list of phone-specific cradles.

**D9**

### Twin Audio® system

**D10.** The Twin Audio® system allows the two rear passengers to listen to the same music source (i.e. radio or CD) through personal headphones, independently of one another and each with their own volume controls.

They are also free to select CD mode while the front occupants are tuned into the radio (or vice-versa) and make full use of functions like track skip and autosearch.

**D10**

### Satellite navigation

**D11.** Vauxhall's satellite navigation systems have been widely acclaimed for their ease of use and high level of information. The CD-ROM-driven system has been enhanced for New Zafira. There is now a split-screen facility, whereby half of the screen displays the route as a map, while directional arrows give immediate information about road junctions. The audible direction guidance prompt now gives details of road numbers and motorway junction numbers, while you can also plan your route to avoid toll roads, if required.

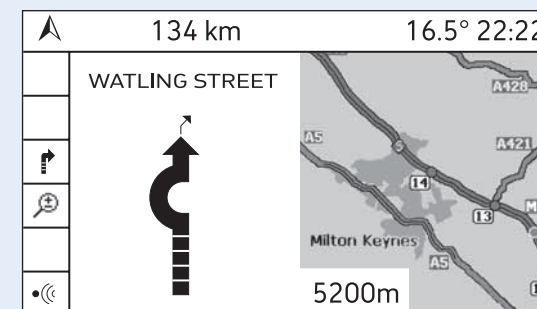

**D11**

Furthermore, the use of the system has been simplified with regard to entering your destination address. Rather than entering the address line by line, the user can find their destination via the on-screen map. Additionally, the system will save the car's current location as an address for ease of use.

The CD 70 also features Traffic Message Channel (TMC), a specific application of RDS used for broadcasting real-time traffic information, delivered to the driver either visually or verbally. TMC can also offer dynamic route guidance – alerting the driver to a problem on the planned route and calculating an alternative route to avoid the incident.

**Standard features (CD 70)** • Automatic re-routing on request • CD-ROMs available for all major European countries • CD-ROM may be replaced by audio CD after route is selected • Display of estimated time remaining and distance to destination • Exact location of vehicle using the GPS (Global Positioning System) and speed sensor • Choice of four different route types: using motorways/avoiding motorways/shortest distance/shortest journey time • Store up to 100 personal destinations • Last 10 destinations stored automatically

# TECHNICAL DATA



## 200PS

2.0i 16v turbo – the most powerful petrol engine in its class



## 150PS

1.9CDTi 16v – the most powerful diesel engine in its class



## 6-SPEED

Six-speed manual and automatic transmissions available

### Petrol engines

	1.6i 16v ECOTEC-4 Twinport	1.8i 16v VVT ECOTEC-4	2.2i 16v Direct ECOTEC-4 aluminium	2.0i 16v turbo ECOTEC-4
Capacity	1598cc	1796cc	2198cc	1998cc
Maximum power	105PS (77kW) @ 6000rpm	140PS (103kW) @ 6300rpm	150PS (110kW) @ 5600rpm	200PS (147kW) @ 5400rpm
Maximum torque	150Nm (111 lb.ft.) @ 3900rpm	175Nm (129 lb.ft.) @ 3800rpm	215Nm (159 lb.ft.) @ 4000rpm	262Nm (193 lb.ft.) @ 4200rpm
Compression ratio	10.5:1	10.5:1	12.0:1	8.8:1
Emission compliance	Euro 4	Euro 4	Euro 4	Euro 4
Configuration	4 cylinders 4 valves per cylinder Double overhead camshafts			
Cylinder head/block	Alloy/cast iron		Alloy/alloy	Alloy/cast iron
Fuel system	Multi-point sequential electronic dual spray fuel injection with air mass metering			
Induction system	Naturally aspirated		Water-cooled turbocharger with air-cooled intercooler	
Throttle control	Electronic cable-free 'drive by wire'			
Service intervals	20,000 miles or 1 year (whichever occurs sooner)			
<b>Benefit in kind company car taxation rates – 2006/07 tax year</b>				
Manual	22%	24%	26%	32%
Easytronic/automatic	–	23%	27%	–

### Diesel engines

	1.9CDTi (120PS) ECOTEC-4 Turbo diesel	1.9CDTi 16v (150PS) ECOTEC-4 Turbo diesel
Capacity	1910cc	1910cc
Maximum power	120PS (88kW) @ 3500rpm	150PS (110kW) @ 4000rpm
Maximum torque	280Nm (206 lb.ft.) @ 2000-2750rpm	320Nm (236 lb.ft.) @ 2000rpm
Compression ratio	18.0:1	17.5:1
Emission compliance	Euro 4	Euro 4
Configuration	4 cylinders 2 valves per cylinder Single overhead camshaft	4 cylinders 4 valves per cylinder Double overhead camshafts
Cylinder head/block	Alloy/cast iron	
Fuel system	High-pressure fuel injection pump and common rail fuel injection	
Induction system	Variable geometry turbocharger with integrated intercooler	
Throttle control	Electronic cable-free 'drive by wire'	
Service intervals	20,000 miles or 1 year (whichever occurs sooner)	
<b>Benefit in kind company car taxation rates – 2006/07 tax year</b>		
Manual	23%	23%
Automatic	28%	28%

– = This engine/transmission combination is not available.

### Petrol engines

An advanced new 1.8i 16v VVT (Variable Valve Timing) engine makes its debut in New Zafira. Double Continuous Variable Cam Phasing (DCVCP) allows at least 90% of the maximum torque to be available between 2200 and 6200rpm, ensuring good performance and flexibility at all engine speeds – along with less frequent gear changes.

Compared to the previous Zafira's 1.8i 16v unit, the new engine develops 12% more power – yet consumes 4% less fuel.

Further contributions to the improved efficiency of the engine are provided by its lightweight construction. The less weight the engine has to move around, the more efficient the vehicle is. In spite of additional features such as DCVCP, Vauxhall engineers succeeded in making the new engine three percent lighter than the previous 1.8i 16v, while achieving increased stiffness and structural strength through extensive stiffening measures in the cylinder head and block. The cylinder block alone is 20 percent lighter than its predecessor.

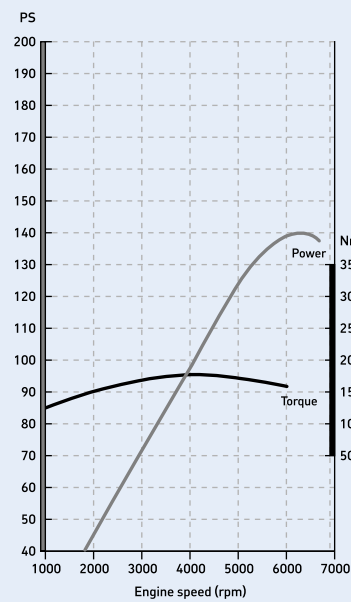

1.8i 16v VVT petrol

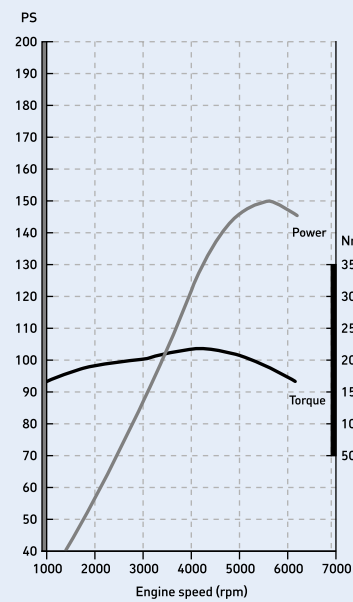

2.2i 16v Direct petrol

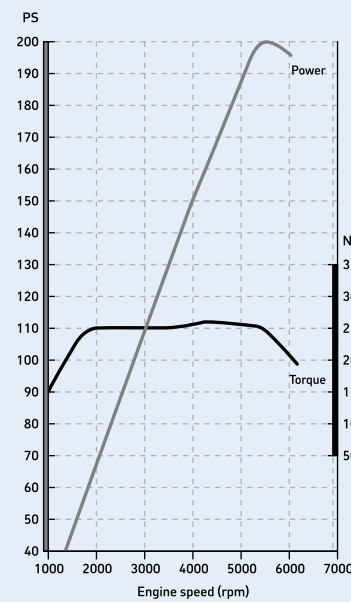

2.0i 16v Turbo petrol

### Diesel engines

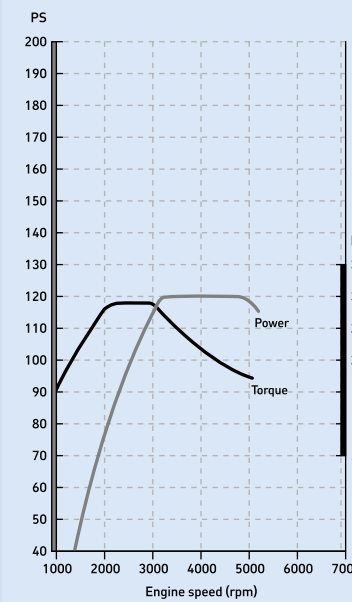

1.9CDTi (120PS) diesel

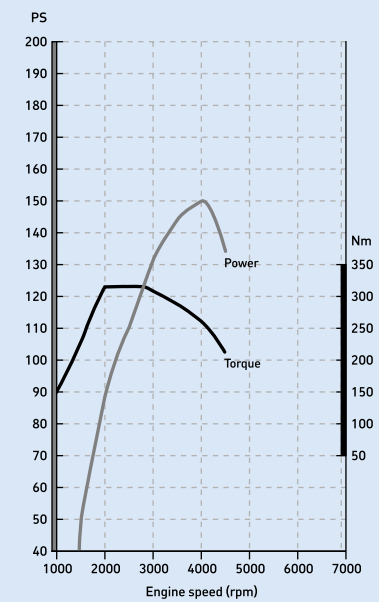

1.9CDTi 16v (150PS) diesel

# TECHNICAL DATA

## Performance, fuel economy and emissions

	Performance (manufacturer's figures)			Fuel economy mpg (litres/100km)			CO <sub>2</sub> emissions (g/km)
	Max. speed (mph)	0-60mph	Acceleration (secs) 30-50mph (4th gear)	Urban driving	Extra-urban driving	Combined figure	
<b>Manual 5-speed</b>							
1.6i 16v Twinport	109	13.4	9.2	30.1 (9.4)	46.3 (6.1)	38.7 (7.3)	175
1.8i 16v VVT	122	10.8	8.1	27.4 (10.3)	44.1 (6.4)	36.2 (7.8)	187
<b>Manual 6-speed</b>							
2.2i 16v Direct	124	9.9	7.6	25.0 (11.3)	44.1 (6.4)	34.4 (8.2)	197
2.0i 16v Turbo (200PS)	140	8.4	6.0	21.2 (13.3)	38.7 (7.3)	29.7 (9.5)	228
1.9CDTi (120PS)	116	11.4	6.8	36.7 (7.7)	54.3 (5.2)	46.3 (6.1)	165
1.9CDTi 16v (150PS)	126	9.7	6.0	36.2 (7.8)	53.3 (5.3)	45.6 (6.2)	167
<b>Easytronic 5-speed</b>							
1.8i 16v VVT	122	12.1	-	28.0 (10.1)	45.6 (6.2)	37.2 (7.6)	182
<b>Automatic 4-speed</b>							
2.2i 16v Direct	118	10.8	-	24.4 (11.6)	42.2 (6.7)	33.2 (8.5)	204
<b>Automatic 6-speed</b>							
1.9CDTi (120PS)	113	11.7	-	28.8 (9.8)	49.6 (5.7)	39.2 (7.2)	194
1.9CDTi 16v (150PS)	123	10.0	-	28.8 (9.8)	49.6 (5.7)	39.2 (7.2)	194

The fuel consumption figures shown comply with EC directive 1999/100 to provide a realistic indication of fuel consumption by taking into account everyday driving conditions, such as cold starts, acceleration and braking. These figures take account of the vehicle's kerbweight, ascertained in accordance with the above regulation. **Important:** the results given relate to the particular car tested. Variations in trim level and equipment may result in slightly higher fuel consumption and CO<sub>2</sub> emission levels than those quoted. Driving style, road and traffic conditions, vehicle mileage and standard of maintenance may also affect fuel consumption; therefore the results do not express or imply any guarantee of fuel consumption attainable.

## Transmissions

- Front-wheel drive
- Five-speed manual gearbox:**
  - Standard on 1.6i 16v/1.8i 16v VVT models
- Six-speed manual gearbox:**
  - Standard on 2.2i 16v Direct/2.0i 16v Turbo/1.9CDTi (120/150PS) models
- Four-speed automatic transmission:**
  - Available at extra cost on 2.2i 16v Direct
- Six-speed automatic transmission:**
  - Available at extra cost on 1.9CDTi (120/150PS) models

Four- and six-speed automatic transmissions are electronically controlled with adaptive driving function and Winter mode, which selects third gear for standing starts in slippery conditions. Fluid drive with torque converter, lock-up clutch and neutral control fuel-saving feature.

## Five-speed Easytronic transmission:

- Available at extra cost on Life, Club and Design 1.8i 16v VVT models
- Gearshift selector for either automatic transmission operation or manual, sequential shift operation via gear lever
- Automatic clutch control
- Winter mode, which selects second gear for standing starts in slippery conditions
- Hydraulically actuated, asbestos-free, self-adjusting single-plate clutch

## Suspension

- Front:**
- Independent. Lightweight MacPherson struts with gas-pressure dampers and coil springs. Anti-roll bar. Hydro-formed subframe offers increased lateral stiffness. Hydraulic control arm bushing gives improved insulation from road noise.
  - Design 2.2i 16v Direct/2.0i 16v Turbo/1.9CDTi 16v (150PS) and all SRi models – uprated springs and dampers with lower ride height
  - SRi – Interactive Driving System with Continuous Damping Control, optional at extra cost **D15**
- Rear:**
- Lightweight torsion beam rear axle with one-piece, hollow cast trailing arms. Built-in anti-roll bar. Progressive-rate double conical mini-block springs and gas-pressure dampers.
  - Design 2.2i 16v Direct/2.0i 16v Turbo/1.9CDTi 16v (150PS) and all SRi models – uprated springs and dampers with lower ride height
  - SRi – Interactive Driving System with Continuous Damping Control, optional at extra cost **D15**

## Brakes

- Front ventilated disc brakes
- Anti-lock Braking System (ABS) with Electronic Brakeforce Distribution (EBD)
- Cornering Brake Control (CBC) **D12**
- Emergency Brake Assist (EBA) **D13**
- Dual circuit, diagonally split braking system
- Front brake pad wear warning

## Steering

- Electro-hydraulic power-assisted steering
- Turning circle (kerb-to-kerb): All models – 11.10m (36.4ft.)

## Fuel tank capacity

- All models – 58 litres (12.8 gallons)

## Electrics

### Alternator:

All models (exc. 2.0i 16v Turbo) – 100A  
2.0i 16v Turbo – 120A

### Maintenance-free battery:

1.6i 16v/1.8i 16v VVT/2.0i 16v Turbo – 55Ah  
1.9CDTi (120/150PS) – 60Ah  
2.2i 16v Direct – 66Ah

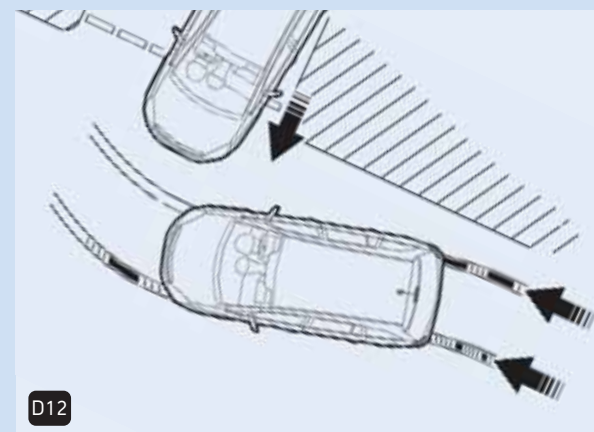

## Anti-lock Braking System (ABS) with Cornering Brake Control (CBC)

**D12.** Cornering brake control makes the car easier to control in extreme situations, particularly when braking sharply on a bend. It is particularly effective when carrying out emergency procedures, such as avoiding a child's ball that's rolled out from the kerb. The system works by sensing the different rotational speeds of the individual road wheels and co-ordinating the level of braking pressure applied to each wheel. CBC is an integral part of New Zafira's comprehensive ABS.

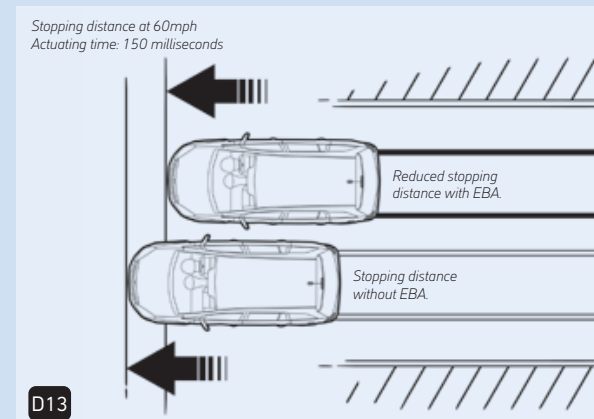

## Emergency Brake Assist (EBA)

**D13.** Emergency brake assist detects the urgency with which the brake pedal is pressed and rapidly increases the pressure to the maximum the system can provide, shortening stopping distances. It also enhances pedal feel.

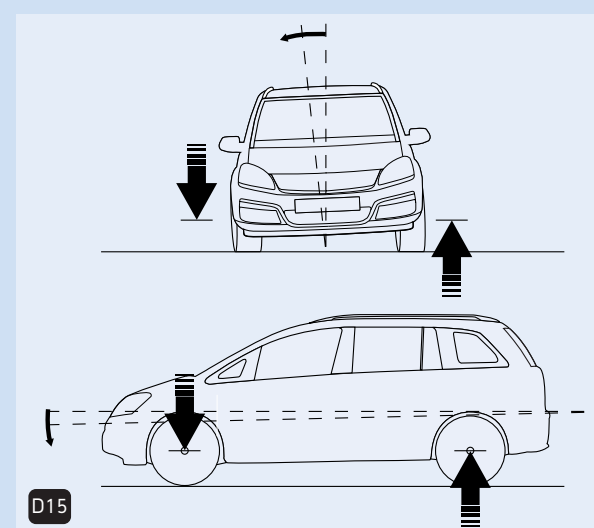

## Sport switch

**D14.** The Sport switch, standard on Design 2.2i 16v Direct/2.0i 16v Turbo/1.9CDTi 16v (150PS) and all SRi models, improves the responses of both the steering and throttle, giving the driver crisper initial acceleration and sharper, more direct turn-in when cornering. On vehicles fitted with automatic transmission, the Sport switch also controls the transmission Sport mode.

## IDS-plus with Continuous Damping Control (CDC)

**D15.** The Interactive Driving System (IDS-plus) chassis – available on SRi models – offers the New Zafira driver an even more sporting driving experience, thanks mainly to the electronic control of the suspension. Pressing the Sport switch activates the CDC function – CDC monitors the roll, pitch and yaw of the car, and changes the rate of damping on each wheel to optimise the handling, effectively stiffening the suspension – but selectively. This means the vehicle will exhibit a reduced rate of roll and pitch, making it more responsive during direction changes and more settled during the braking/turn-in/acceleration transition when cornering. CDC is a major breakthrough in the Zafira segment.

# DIMENSIONS AND WEIGHTS



**1500kg**  
Maximum towing weight



**652kg**  
Maximum carrying capacity



**1820 litres**  
Maximum luggage capacity

## Loadspace dimensions

	mm	inches
Maximum floor length – behind front seats, second-row seat back lowered	1809	71.2
Maximum floor length – behind front seats, second-row seat folded and stowed	1525	60.0
Maximum floor length – behind second-row seat	1088	42.8
Maximum floor length – behind third-row seat	405	15.9
Maximum floor width	1114	43.9
Width between wheel arches	1071	42.2
Tailgate aperture height	893	35.2

## Luggage capacities (ECIE method)

	litres	cu.ft.
Behind third-row, to glass line	140	4.9
Behind second-row, to glass line	645	22.8
Behind front seats, to glass line	1070	37.8
Behind front seats, to roof	1820	64.3

## Flex7 seat configurations

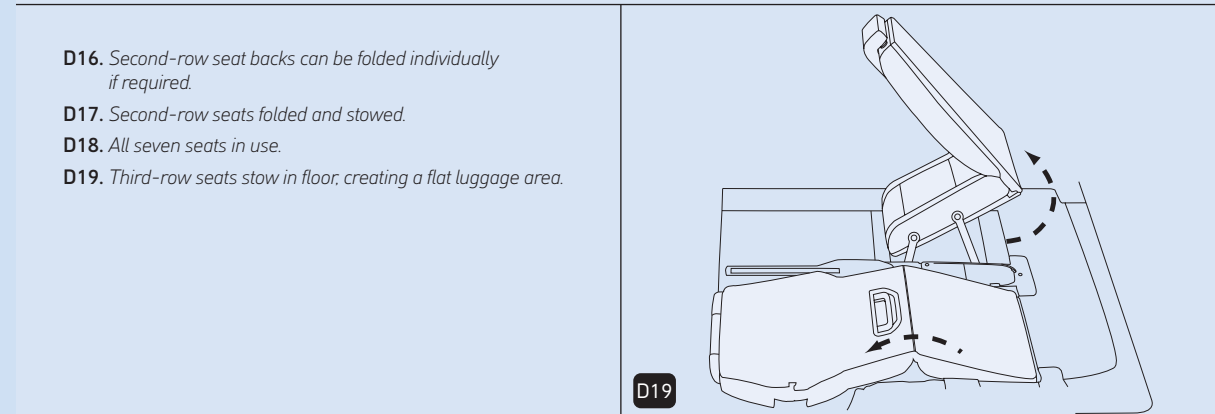
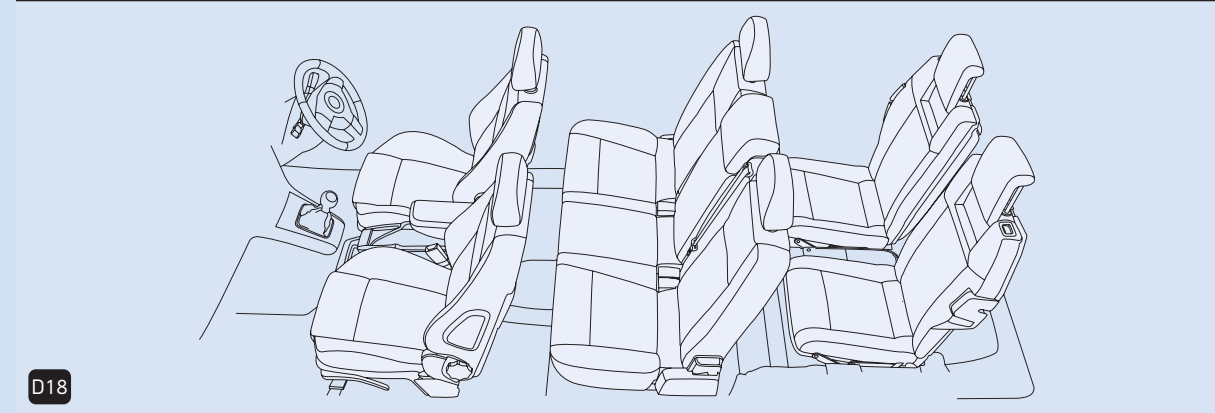
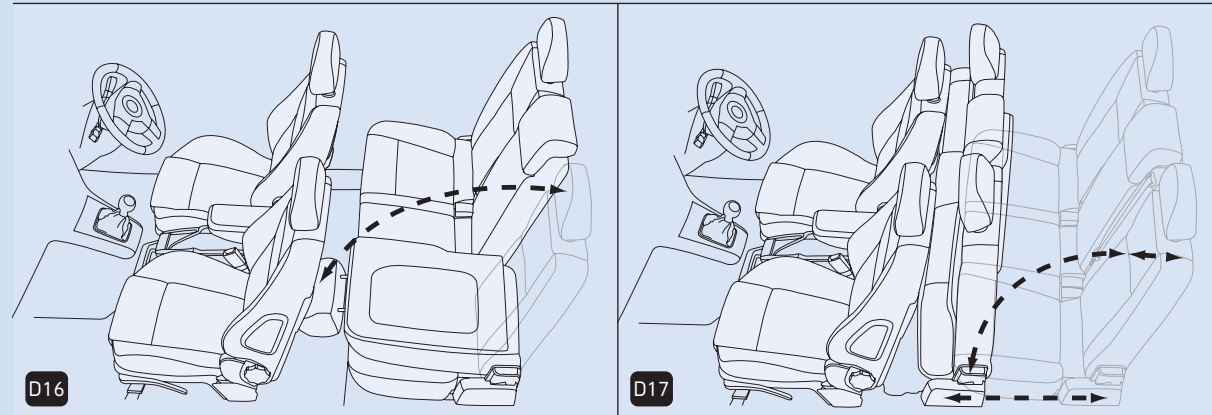

**D16.** Second-row seat backs can be folded individually if required.

**D17.** Second-row seats folded and stowed.

**D18.** All seven seats in use.

**D19.** Third-row seats stow in floor, creating a flat luggage area.

## Exterior dimensions millimetres (inches)

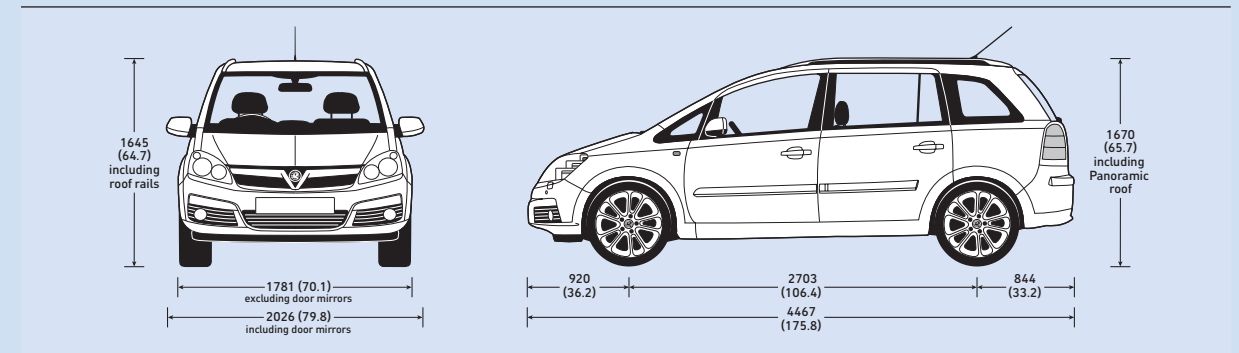

## Weights and towing data kg

	Kerbweight (Gross vehicle weight)	Max. towing weights Trailer with brakes (without brakes)
1.6i 16v Expression	1430 (2075)	1000 (750)
1.6i 16v Life	1445 (2090)	1000 (750)
1.6i 16v Club	1455 (2090)	1000 (750)
1.8i 16v VVT Life	1443 (2095)	1200 (750)
1.8i 16v VVT Club	1453 (2095)	1200 (750)
1.8i 16v VVT Design	1468 (2095)	1200 (750)
1.8i 16v VVT SRi	1463 (2095)	1200 (750)
2.2i 16v Direct Life	1510 (2150)	1500 (750)
2.2i 16v Direct Life auto	1535 (2175)	1500 (750)
2.2i 16v Direct Club	1512 (2150)	1500 (750)
2.2i 16v Direct Club auto	1537 (2175)	1500 (750)
2.2i 16v Direct Design	1526 (2150)	1500 (750)
2.2i 16v Direct Design auto	1551 (2175)	1500 (750)
2.2i 16v Direct SRi	1523 (2150)	1500 (750)
2.2i 16v Direct SRi auto	1548 (2175)	1500 (750)
2.0i 16v Turbo (200PS) Design	1551 (2175)	1500 (750)
2.0i 16v Turbo (200PS) SRi	1548 (2175)	1500 (750)
1.9CDTi (120PS) Life	1553 (2195)	1300 (750)
1.9CDTi (120PS) Life auto	1583 (2225)	1400 (750)
1.9CDTi (120PS) Club	1558 (2195)	1300 (750)
1.9CDTi (120PS) Club auto	1588 (2225)	1400 (750)
1.9CDTi (120PS) Design	1569 (2195)	1300 (750)
1.9CDTi (120PS) Design auto	1599 (2225)	1400 (750)
1.9CDTi (120PS) SRi	1566 (2195)	1300 (750)
1.9CDTi (120PS) SRi auto	1596 (2225)	1400 (750)
1.9CDTi 16v (150PS) Design	1569 (2205)	1500 (750)
1.9CDTi 16v (150PS) Design auto	1599 (2235)	1500 (750)
1.9CDTi 16v (150PS) SRi	1566 (2205)	1500 (750)
1.9CDTi 16v (150PS) SRi auto	1596 (2235)	1500 (750)

**Gross vehicle weight** is the total permissible weight of the vehicle including passengers and their luggage. To determine total carrying capacity, deduct kerbweight from gross vehicle weight. The **maximum roof rack loading** should not exceed 75kg. The **maximum towing weights** are based on the ability of the car, with two occupants of 70kg each, to restart on a 12% gradient, which is approximately 1 in 8.3, at sea level. At altitudes above 1500 metres, the engine output may drop with a corresponding reduction in towing capability. Any extra weight, such as luggage or additional passengers, should be deducted from the maximum towing weight. With a trailer fully loaded, **maximum noseweight** should not exceed 75kg. Always fit Vauxhall towing attachments and accessories available from your Vauxhall retailer.



## VAUXHALL BY DESIGN

Styling and accessories



Vauxhall DUO ISOFIX child seat.



Ear hook and earplug headphones for Twin Audio®

### VXR exterior styling

- VXR styling pack one
  - front lower spoiler, rear roof spoiler, rear lower skirt and side sills
- V-grille logo trim
- Front lower spoiler
- Rear roof spoiler
- Rear lower skirt
- Side sills
- Door mirror covers
- Door handle covers
- Tailgate handle – matt silver-effect

### Irmscher exterior styling

- Sports silencers
- Front lower spoiler
- Cross hatch grilles
- Rear roof spoiler
- Side sills
- Door handle spoilers/covers
- Fuel flap cover – aluminium effect

### Irmscher interior styling

- Aluminium pedals (manual)
- Interior door handle covers (pair)
- Three spoke steering wheel – leather/matt chrome effect
- Velour floor mats with heel protector and 'Irmscher' logo (set of four)

### Irmscher suspension<sup>1</sup>

- Uprated and lowered spring kit

### Irmscher alloy wheels

- Softstar (15/16/17-inch)
- Delta (17-inch)
- Stila (15/16/18-inch)
- Stila – polished (18-inch)
- Evo Star/Evo Star Titanium (18-inch)

### Interior – cabin area

- Rubber floor mats
- Velour floor mats
- Deluxe velour floor mats
- Glovebox organiser
- Front passenger seat storage net
- Rear seat protection cover
- Storage bag including rucksack
- Waste bag

### Interior – load area

- Anti-slip mat
- Cargo liner
- Dog guard<sup>2</sup>
- Space divider grid<sup>3</sup>
- Vertical load-restraining net<sup>2</sup>
- Electrically chilled 12-litre cool bag – 230v/12v power lead for cool bag – battery guard for cool bag – extension lead (4m) for cool bag
- Load-restraining floor net

### FlexOrganiser® system<sup>4</sup>

- Side rail kit
- Flexible divider net
- Vertical divider mesh with pockets
- Side net pocket
- Side rail clip
- Side rail hook
- Side rail strap
- Side rail storage box

### Safety

- Origin b2 driver safety and information system
- First aid kit
- Warning triangle
- Fire extinguisher – 1kg or 2kg
- Temporary tyre repair kit

### Security

- Locking wheel bolts
- Steering wheel security bar
- MetaSystem alarm

### Exterior

- Mudflaps
- Headlight protectors
  - standard
  - carbon fibre-effect
- Continental touring headlight converters
- Bumper load protection foil
- Rear parking distance sensor

### Load carriers

#### Roof carrier system

- T-track base carrier
  - with roof rails
  - without roof rails
- Premium bicycle carrier
- Side loading bicycle carrier
- Ski/snowboard carriers
- Extendable ski carrier
- Sport roof box (450 litres)
- Travel roof box (450 litres)
- Surfboard/windsurf board carrier
- Interior bicycle carrier

#### Tow bar carrier system

- Tow bar mounted bicycle carrier (two bicycles)
- Extension for third bicycle

### Practical

- Spare bulb kit (not for AFL headlights)
- Jump leads
- Fuel cans
- Stretch tow rope
- Towing rod

### Audio and navigation units

- Stereo radio/CD/MP3 player
- Stereo radio/CD players
- Stereo radio/cassette/CD autochangers
- CD autochangers
- Satellite navigation/stereo radio/CD/DVD player systems
- Removable DVD player<sup>5</sup>

### Audio accessories

- Portable CD storage bag
- Portable CD storage box
- Sun visor CD storage
- Ear hook and earplug headphones for rear seat Twin Audio®
- Single-DIN fascia kit

### Towing

- Fixed tow bar with 12N, 12N/12S or 13-pin electrics
- Detachable tow bar with 12N, 12N/12S or 13-pin electrics
- Towing mirrors

### Child seats<sup>6</sup>

- Vauxhall BABY-SAFE
- Vauxhall DUO ISOFIX
- Vauxhall KID
- Baby mirror

- 1 = Not for use with towing equipment.
- 2 = Requires fitting kit (retailer-fit only) if vehicle is not equipped with either the optional factory-fit dog guard fixing points or vertical load restraining net.
- 3 = Use in conjunction with dog guard.
- 4 = Side rail kit must be purchased to allow fitment of FlexOrganiser® accessories if factory-fit FlexOrganiser® pack is not purchased.
- 5 = Not available with Panoramic roof pack.
- 6 = Restrictions apply regarding the fitment and positioning of child seats. Please refer to your Vauxhall retailer for more information.

For more details on the accessory range pick up the latest Vauxhall by Design Car Accessories brochure and Car and Accessory Price Guide or visit: [www.vauxhall.co.uk/accessories](http://www.vauxhall.co.uk/accessories)



## TRUST VAUXHALL

There are more important things to life than worrying about how to finance and service your car, where to go in the event of an accident and how we go about meeting the transport challenges of the future. So when you choose Vauxhall, you can rely on us to safeguard both you and the environment around you, leaving you free to concentrate on the more important business of enjoying your car!

### USEFUL CONTACTS

- |                                      |               |
|--------------------------------------|---------------|
| • Vauxhall Mobility                  | 0800 731 5267 |
| • Vauxhall Military/Diplomatic Sales | 0870 442 1580 |
| • Vauxhall Rental                    | 0870 442 1567 |
| • Fleet Support                      | 0870 010 0651 |
| • Vauxhall Accident Support          | 0800 010 304  |
| • Sureguard extended warranty        | 0870 752 7020 |
| • Vauxhall Insurance                 | 0870 024 0240 |
| • Vauxhall Leasing                   | 0870 737 2557 |



### For more information...

For a brochure on any Vauxhall model (up to a maximum of three per caller) or location of your nearest Vauxhall retailer please **Lo-call 0845 600 1500**.

Alternatively, details can be found on our website at [www.vauxhall.co.uk](http://www.vauxhall.co.uk)

### Protecting the environment

At Vauxhall, we take a broader viewpoint than the design, manufacture and selling of cars. We are committed to looking after the environment throughout the life cycle of the vehicle.

Our products are increasingly winning environmental awards, both through the use of more recycled materials and by becoming cleaner and more efficient. For information on Vauxhall's efforts to achieve an environmentally sustainable future, including information on Design for Recycling, take-back of End-of-Life Vehicles (ELVs), and the recycling of ELVs, see [www.vauxhall.co.uk/recycling](http://www.vauxhall.co.uk/recycling).

Looking to the future, we are also investing heavily in the biggest potential breakthrough of the next decade – the hydrogen fuel cell car.

### Customer Care Commitment

Providing drivers with the highest standards of aftersales support, Vauxhall offers a three-year Customer Care Commitment\* package. Highlights include:

- A one-year unlimited mileage manufacturer's warranty
- A second and third year no-fee customer option warranty to 60,000 miles from first registration
- Vauxhall Assistance for 12 months from first registration
- Roadside breakdown cover
- Free loan car

\* = Warranty is only available on vehicles sourced from Vauxhall Motors Ltd. Terms and conditions apply – please see your Vauxhall retailer for details.

### Anti-perforation warranty

Your new Vauxhall also comes with a body panel anti-perforation warranty for a period of at least six years from the date of first registration.

### Vauxhall Assistance

Vauxhall Assistance is operated by the AA and is provided for 12 months from date of first registration and covers everything from accidents, mechanical breakdown and flat tyres to illness while driving. With Vauxhall Assistance, help is literally just a free\*\* phone call away, 24 hours a day, 365 days a year!

\*\* = Mobile phone users will be charged at their standard tariff.

### Complete Motoring Plan

Vauxhall's Complete Motoring Plan is a simple way to budget for all your motoring needs. For just a small monthly payment all your car's routine servicing and maintenance is covered†, you will receive full Vauxhall Assistance cover and MOT test insurance for the duration of the plan. You can buy peace of mind for 24, 36 or 48 months by either an up front payment or interest free direct debit.

† = Excludes tyres, exhausts and windscreens. Terms and conditions apply.

### Vauxhall Leasing

As Vauxhall's own contract hire and fleet management operation, Vauxhall Leasing provides a one-stop-shop for competitive car and van leasing solutions – for business users and private individuals. Working with the Vauxhall retailer network, we combine the support of a national contract with the convenience of a local contact. For further information, please see your local Vauxhall retailer or call us on 0870 737 2557. Alternatively, visit our website at [www.vauxhall-leasing.co.uk](http://www.vauxhall-leasing.co.uk)

### Buying your car

For straightforward advice on a simple, affordable way into a new or used car ask your Vauxhall retailer. GMAC offers a wide range of finance solutions that are easy to understand, flexible enough to suit every need and convenient to arrange at your Vauxhall retailer.

### In the event of an accident...

Vauxhall Accident Support is designed to help keep you mobile following an accident, providing prompt recovery to a Vauxhall Approved Accident Repair Centre where your vehicle can be repaired to a high standard. The service is free to all Vauxhall drivers. For further information *Freefone* 0800 010 304.

### Sureguard protection

Should you wish to enjoy the range of benefits provided by Vauxhall Assistance for a full three years from first registration, then new Sureguard Assistance is for you. If you are a higher mileage driver or plan to keep your vehicle for longer than the standard warranty period, you need the protection of Sureguard Warranty. This provides all the peace of mind of a parts and labour warranty – including Assistance – for the duration of your cover. Sureguard Warranty and Sureguard Assistance now come with the added peace of mind of Sureguard MOT Warranty. For details contact your local Vauxhall retailer or call 0870 752 7020.

### Specialist Mobility advice

 Motability accredited Vauxhall retailers can provide special mobility help and advice. Blue badge holders are entitled to very favourable discounts when purchasing new vehicles. For full details contact your local Motability accredited Vauxhall retailer or *Freefone* 0800 731 5267.

### Servicing and maintenance

The best way to maximise the performance and reliability of your Vauxhall is to have all routine servicing and maintenance carried out at a Vauxhall retailer. There are around 400 retailers nationwide.