

John Neal Bookseller

Supplying calligraphers, lettering artists, illuminators, bookbinders and papercraft enthusiasts worldwide with books, tools, and materials since 1981.



ORDER NOW! TOLL FREE: 800-369-9598 * WEB: WWW.JOHNNEALBOOKS.COM

BOOKBINDING BOOKS

Carol Barton

B2694. The Pocket Paper Engineer by Carol Barton. 2005. 67pp. 6.5"x9.75". Hidden spiral. Hardcover \$24.00

A fun, clearly written instructional book based on Barton's 20 years experience teaching paper engineering and pop-ups to students of all ages. The book includes page pockets with pull out patterns with step-by-step directions printed on the backs. This workbook includes lots of construction and design tips, assembly and production techniques, pictures of finished pop-ups, and easy-to-follow illustrations on how to create your own pop-ups. *Carol's pop-ups are also featured in The Penland Book, see page 3.*

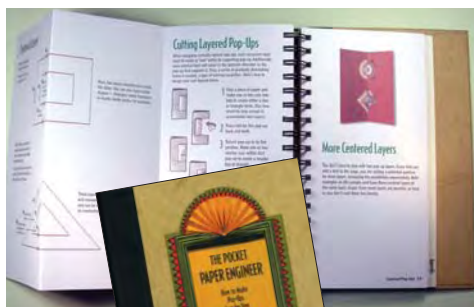

See page 34 for index.



Altered Books

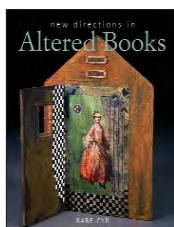

B2834 New Directions in Altered Books by Gabe Cyr. 2006. 128pp. 8.5"x11". Hardcover \$19.95. JNB Price \$17.99

New The first 43 pages presents history, tools, materials and techniques for altered books. The rest of

the book is projects and wonderful gallery pages. The work of a variety of artists is highlighted. The selection is broad and varied. It tends to the artist's book influence rather than the stamp, sticker, embellished mode.

Bookbinding

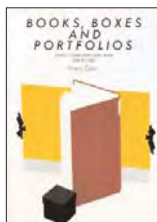

B1207. Books, Boxes & Portfolios: Binding, Construction and Design, Step-By-Step by Franz Zeier. 1990. 304pp. 7.25x10. Hardcover. \$39.95

New Fully illustrated, step-by-step manual for sewn and adhesive bindings. Presents projects for making

boxes, portfolios, book covers, albums, and mats. Stresses design principles and aesthetics. A standard reference since it was first published in 1983. Translation of original Swiss text.



B2671. The Complete Book of Bookbinding by Josep Cambras. 2004. 160pp. 9"x11.75". Hardcover. \$29.95 JNB Price \$26.95

A summary of bookbinding techniques written by a professor of bookbinding at the Escola d'Arts i Oficis in Barcelona. It provides a precise, systematic, and fully illustrated approach to the craft. Everything is covered in detail: tools and materials, the parts of the book and the binding, and protective features. Handsome ideas for decorating the cover (stamping, gilding, engraving) abound, as do suggestions for

restoration. Eight specific and detailed projects for binding form the heart of the volume, which includes binding in fabric, making a jacket with flaps for graphic works, and constructing a leather-trimmed slipcase.

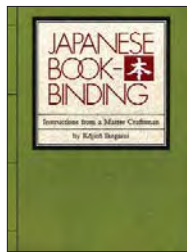

B090. Japanese Bookbinding: Instructions from a Master Craftsman by Kojiro Ikegami. 1986. 148pp. 7.75"x10.5". Hardcover \$34.95. JNB Price \$31.50

New Presents easy-to-follow instructions for the major Japanese styles of binding and folding boxes.

Includes side-stitched, accordion fold, scrolls and flutter books. The most thorough book on the subject; a popular text for the last 20 years.



B2753. Pockets, Pullouts, and Hiding Places: Interactive Elements for Altered Books, Memory Art and Collage by Jenn Mason. 2005. 160pp. 8.5"x11". Paper \$24.99. JNB Price \$22.45

Teaches paper engineering techniques for making 3D and interactive "paper tools" such as vellum pockets or hinged doors that reveal mini books underneath. Complete patterns and step-by-step instructions for 27 "tools" are followed by examples of their use. Full color throughout.



B2329. Tini Miura 1980-1990: A Master's Bibliophile Bindings by Kyoiku Shoseki. 1991. 199pp. 10"x15.5". Hardcover \$150. Sale \$65.00

sale Page after page of Miura's designer leather bindings (169 total) reproduced (front, back, and spine) in glorious full color. The last sections cover her book design, posters, and pamphlet. A glorious book at a reasonable price.



B2663. Woven & Interlocking Book Structures by Claire Van Vliet and Elizabeth Steiner. 2002. 142pp. 7.5"x10". Paper **\$35.00**

Instead of using sewing or glue, these book structures use woven and interlocking paper to bind the pages together. There are detailed, step-by-step diagrams and instructions for the dozen books with several variations. Examples of finished books are shown for each structure. This hard to find title was a fast seller at Confluence.

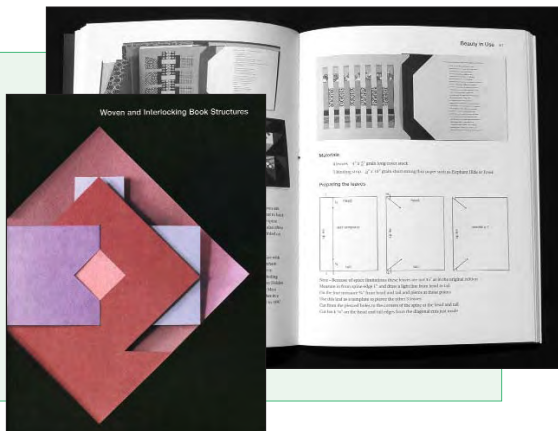

B2670. The Penland Book of Handmade Books: Master Classes in Bookmaking Techniques. 2004. 208pp. 8.5"x11. Hardcover. \$34.95 JNB **\$32.50**

A technical and inspirational guide that showcases 10 contemporary book artists who have taught at Penland's bookbinding masterclass. 400 photographs highlight the crafters as each one demonstrates the details of their particular expertise. Marvel at the beauty of Dolph Smith's sculptural books, the exquisite structure of Jim Croff's carved wood covers and metal closures, the intricacies of Barbara Mauriello's handmade boxes and slipcases, and the secrets of Carol Barton's playful pop-ups. Reflective essays by all the artists.



BOOKMAKING & KIDS

Paul Johnson

Paul Johnson is an educator who has now written three instructional books on using the book arts as a teaching vehicle for other subjects in the school curriculum. He shows you how to integrate simple book projects into writing, history, science, and more

B2698. Literacy through the Book Arts by Paul Johnson. 1993. 168pp. 8"x10" Paper **\$21.50**

Using simple, easy-to-follow instructions, supported throughout with clear diagrams and examples of children's work, Johnson demonstrates how scores of different book forms can be made from a single sheet of paper. Suitable for classroom instruction for grades K-5.

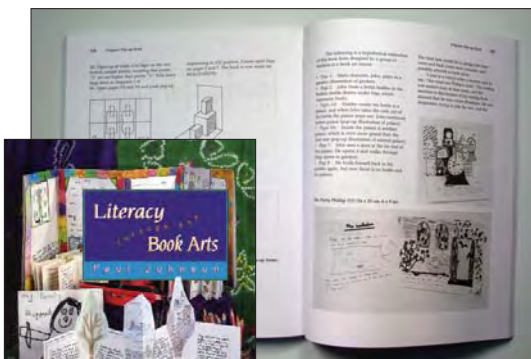

See page 4 for B2393. **Making Books that Fly, Fold, Wrap... \$12.95**

B2816. Get Writing: Creative Book-making projects for Children by Paul Johnson. 2005. 64pp. 8.25"x10.75". Paper **\$17.50**

New Contains more than 100 ideas for book-making projects that encourage children to write for pleasure. 25

book structures (pop-up, shape, zigzag, origami, flap, etc) with variations and step-by-step instructions. For teachers and home-schoolers. Projects are a gateway to writing and numeric skills and provides hints on relating to English, math, science, history, geography and art. Examples by children 4-7, but projects suitable for older children.

B2779. Making Books: Over 30 Practical Book-Making Projects for Children by Paul Johnson. 2000. 64pp. 8.25"x10.75" Paper **\$17.50**

New Presents book-making ideas that support literacy teaching across the curriculum (ages 5-11). Easy-to-

make storybooks, pop-up information books, diaries and poetry folders, plus many special and unusual books are illustrated. Each project includes step-by-step instructions, a photo of the finished work, and helpful tips on lesson planning (including age range, advance preparation, how long to allocate for each project & how to use the project in a classroom setting)



BOOKBINDING BOOKS

See page 34 for index

The Decorated Journal: Creating Beautifully Expressive Journal Pages by Gwen Diehn. 2005. 128pp. 8.5x10. **B2910.** Paper \$16.95 **B2734.** Hardcover \$24.95. JNB Price \$19.95

This follow up to *The Decorated Page*, presents more of the same and that's a good thing! More great photos, ideas, and examples. Build layered pages, use transparency, and more. Includes sections on making journals and customizing store bought journals.

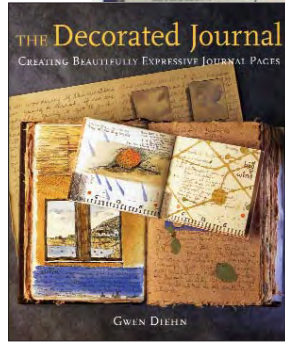

B2509. The Decorated Page: Journals, Scrapbooks, & Albums Made Simply Beautiful by Gwen Diehn. 2002. 128 pp. 8-1/2"x10". Paper \$17.95. **JNB \$16.95**

Presents simple, unintimidating decorating techniques for turning personal journals into visual treasures. Color wash paper; rubber stamp designs; add secret pockets and tuck mementoes inside. Insert tabs for fast & easy reference, or for purely visual appeal. Include windows between pages to enhance the sense of curiosity & discovery. See how to build 10 different pages that perfectly marry form & content, complete with an example illustrating the beauty of each approach.



B2782. Expressive Handmade Books by Alisa Golden. 2005 144pp. 8.5"x 11". Hardcover. \$24.95 **JNB \$22.50**

In her third book on binding, Golden presents instruction on structure, design and content. Projects include accordion and fold books including miniatures, side binding with cross-stitching or laced edges, sewn signatures, portfolios, pop-ups. Full-color throughout. See johnnealbooks.com for Golden's *Creating Handmade Books* (B2295, \$17.95) and *Unique Handmade Books* (B2464, \$17.95)

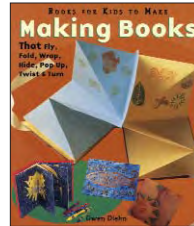

New in paper!
B2393. Making Books that Fly, Fold, Wrap, Hide, Pop-up, Twist & Turn Books for Kids to Make by Gwen Diehn. 1999 (2006). 96pp. 8.5"x10". Paper \$12.95

This full-color step-by-step instruction manual includes projects that magically unfold like a map, contain cards that slip into pockets, include pop-ups perfect for celebrating all types of occasions, and tell stories on a scroll.

Michael Jacobs

B2799. Books Unbound: 20 Innovative Bookmaking Projects by Michael Jacobs. 2006. 128pp., 8.5x11. Paper \$22.95. **JNB \$19.95**

New Michael's third book of projects is another winner. Learn how to create pop-up designs, multiple layers, and special folds that are sculptural, multi-dimensional and clever. Complete step-by-step instructions make these great 3D and layered designs achievable. Includes templates, full color photos of finished projects, and variations.

B2674. Cards That Pop-Up, Flip & Slide by Michael Jacobs. 2005. 96pp. 8.5"x11". Paper. \$19.99 **JNB Price \$17.95**

One-of-a-kind cards with moving parts such as pop-ups, sliders, and flaps. Using step-by-step instructions and 22 easy-to-follow templates, readers will

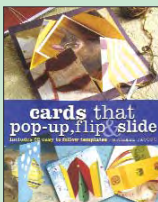
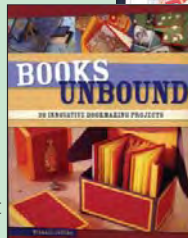

learn how to: put together clever and dynamic interactive cards using simple tools

that are easy to find in craft stores, use a variety of papers, from handmade and printed to recycled, for unique graphic looks, create their own envelopes for a stunning total package, jazz up any project using inks, collage, colored pencils, and more!

B2548. Creative Correspondence by Michael & Judy Jacobs. 2003. 96pp. 8.5"x11". Paper \$19.99. **JNB \$18.95**

Includes more than 15 step-by-step projects including letters and envelopes with photo inserts, stapled booklets, envelope pockets, acetate address windows, and clever self-mailers.



CALLIGRAPHY BOOKS



New in Paper!
B2712. Afrikan Alphabets: The Story of Writing in Afrika by Saki Mafundikwa. 2004. 171 pp.

8.5"x8.5". Paper **\$16.95**

New African alphabets have rich cultural and artistic histories with many still in use today. An entertaining, anecdotal and visual feast. Features over 20 writing systems (pictographs, mnemonic devices, syllabaries and alphabets) from across the African continent and the Diaspora. Includes the Ethiopian script, as well as more recent and less familiar ones.



B2886. Arabic for Designers by Mourad Boutros. 2006. 224pp. 7.25"x8.25" Hardcover **\$35.00**. JNB Price **\$32.50**

New With more than 200 examples of the best in contemporary Arabic typography and graphic design, this book is an illustrated primer on how to work with Arabic and understand and respect its cultural nuances. Focuses on the cross-hybridization of Latin and Arabic graphic design approaches – a process that can yield incredibly innovative, beautiful and successful results. Examples and case studies include newspaper and television news typefaces, book jacket designs, logo-type conversions, clothing design & art.

B2746. An Leabhar Mor: The Great Book of Gaelic edited by Malcolm Maclean and Theo Dorgan. 2002. 321pp. 10.25"x8.5". Paper **\$34.95**

A project of Gaelic (Scottish and Irish) poets, artists and scribes & a typographer. The 100 poems are drawn from the last 1500 years and is presented in both Gaelic and English. 50 Scottish and 50 Irish visual artists – including painters, printmakers and pho-



tographers – created a work in response to the text. Full color.

GREAT BOOK OF GAELIC Video I Am the Tongue: Is Mise an Teanga. 84 min.

V31. VHS. \$34.95 DVD06. (computer only) \$34.95

This documentary is about Gaelic (both Irish and Scottish), its contemporary poets and their encounters with 100 visual artists in The Great Book of Gaelic.



B2131. An Animated Alphabet by Marie Angel. 1996. 64pp. 5-5/8"x8". Paper **\$12.95**

Marie Angel's delicate alphabet book is in print again, but this time finely reproduced in full color. The original manuscript was on vellum, this reproduction is slightly larger than actual size.

Angel's animals are combined with her versals. 28 illustrations. A treasure.

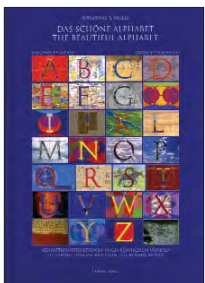

B2761. The Beautiful Alphabet: Lettering Designs Based on the Roman Model by Johannes A. Muess. 2004. 80pp. 8.5"x12". Hardcover **\$35.00**

Using both geometry and an artist's eye Muess presents the Roman alphabet a letter at a time. For each, a Roman inscription, a

Renaissance or 20th century exemplar are provided. The progress of the construction of each letter is shown with steps for basic shape, varying thickness of line, addition of serifs, and fine corrections.

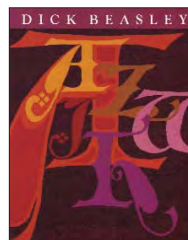

B1811. Dick Beasley.

Introduction by Leana Fay. 1993. 40pp. 8.5"x10". Paper **\$16.50**

New This exhibit catalog reproduces 24 of Beasley's works including traditional calligraphy pieces, jewelry, porcelain, stoneware, tapestry, and his colorful paintings that include letters as a major element. Most illustrations in full color. Also provides lists by year of his lectures/workshops and his exhibits.

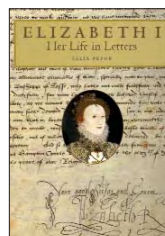

B2823. Elizabeth I: Her Life in Letters by Felix Pryor. 2003. 144pp. 9"x11.75". Hardcover **\$34.95. JNB Sale \$17.50**

New This handsome volume reproduces in color 60 manuscripts – either by Elizabeth I (1533-1603) or to her. Each is accompanied by a



running commentary that explains the document and places it in its historical context, and selected transcriptions or, where necessary, translations from the originals. Her early letters were written in a beautiful italic.

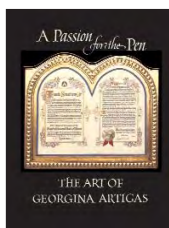

B2831. A Passion for the Pen: The Art of Georgina Artigas edited by Brenda Casey Zoby. 2006. 64pp, 8.5"x11". Paper \$24.95. **JNB Price \$19.95** through 12-31-06

New There are 32 pages with pointed pen lettering, mainly on invitations, certificates and awards, logos, and 8 art pieces from the Calligraphers Engagement Calendars along with many traditional American style illuminated recognition/retirement/resolution scrolls. Born in Cuba, Artigas emigrated to the USA in the 60's and worked for the Ames & Rollinson Studio in NYC for nearly a decade before moving to Miami and setting up her own studio. 28 full color plates.

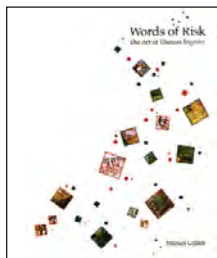

B900. Words of Risk: The Art of Thomas Ingmire by Michael Gullick. 1989. 90pp. 65 illus. many in full color. 9"x12". Paper \$25. **JNB \$16.99**

safe Using words as subjects, Ingmire's work has progressed from the trans-

scription of texts to complex multi-layered visual statements. His juxtaposition of and interplay between words & images challenges the traditional role of calligraphy as "decorated writing." The book describes the work and working process of Ingmire & reproduces virtually all of his major pieces, many in full color.

CALLIGRAPHY INSTRUCTIONAL

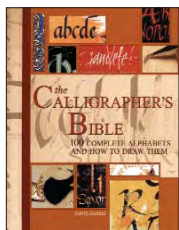

B2623. The Calligrapher's Bible: 100 Complete Alphabets and How to Draw Them by David Harris. 2003. 256pp. 6.3"x8.2". Hardcover, hidden spiral. \$24.95 **JNB Price \$22.50**

A brief section on tools, materials and techniques is fol-

lowed by an amazing array of alphabets: medieval and modern, formal and informal. Each has an exemplar alphabet with ductus, including pen angle changes within strokes for certain alphabets. The opposite page has instructions on the basic structures of the letters for the hand. Includes broad edge, pointed pen, and brush alphabets. The small size & spiral format makes it easy to use. (Note: The instructional photos for the pointed pen script alphabets do not follow the standard practice in the USA).



B1994. Calligraphic Flourishing: A New Approach to an Ancient Art by Bill Hildebrandt. 1995. 132pp. 7"x10". Paper **\$16.95**

"Flourishing" here covers swashes, cadels, cartouches, and intricate knotwork patterns used to embellish letters, text or as

stand alone ornaments. Hildebrandt covers the strokes and principles for proper flourishing, from simple curves, spirals and loops to complex cadels and cartouches. His contagious sense of humor is evident as is his long experience teaching calligraphy.

Flourishes, like letters, can be done well or badly & often a scribe attaches clumsy flourishes to decent letters. This book will help you understand how to make decent embellishments.

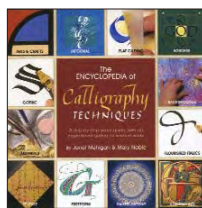

B2762. The Encyclopedia of Calligraphy Techniques by Mary Noble and Janet Mehigan. 2005. 160pp. 8.75"x8.75". Hardcover \$27.95. **JNB Price \$24.95**

This manual for beginning and intermediate scribes covers all the main hands plus edged brush and ruling pen. Includes an extensive section on illumination techniques plus experimental gilding and decorative borders. The extensive and superb gallery brings together traditional and experimental practitioners. Plenty here to inspire you!

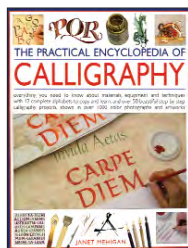

B2889. The Practical Encyclopedia of Calligraphy by Jan Mehigan. 2006. 256pp. 9.25x11.75. Hardcover \$29.95. **JNB Price \$27.50**

New Janet Mehigan is an English scribe.

Everything you need to know about materials, techniques and equipment, plus over 50

beautiful step-by-step projects – shown in 800 color photographs and artworks.

Also by Janet Mehigan, see page 30

B2455. Illumination for Calligraphers. \$21.95

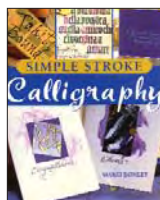

B2825. Simple Stroke Calligraphy by Marci Donley. 2006. 128pp. 8.5"x11". Hardcover \$24.95. **JNB Price \$22.50**

New This beginners manual teaches four hands:

Gothic, Italic, Uncial and Copperplate showing each stroke

in sequence for each letter. The exemplar alphabet is shown in black. The strokes and sequence for each letter are then individually shown using different colors of transparent ink. (Gothic by Virginia Farr-Jones, Italic by Carri Imai, Uncial by Jane Shibata, Copperplate by DeAnn Singh). Includes worksheets, advice on tools and materials, brush lettering and shortcuts to spacing and drawing guidelines. Donley is from Southern California and the book includes calligraphy by several of her fellow Society for Calligraphy scribes, all reproduced in full color.



SHEILA WATERS

Save with the introductory price through 12-31-06.

FOUNDATIONS OF CALLIGRAPHY

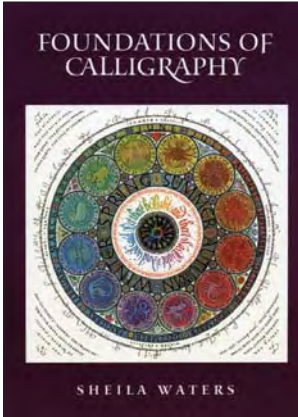

B2769.

Foundations of Calligraphy by Sheila Waters. 2006. 126pp. 9"x11.25".

Concealed spiral binding \$35.00 **\$29.95 introductory price.** USA orders are shipped free via media mail. Foreign orders of 10 or more copies are shipped free (via

Surface M-Bag). **Free shipping & intro price offers good only through December 31, 2006. Order your copy today!**



Sheila Waters' long awaited

Foundations of Calligraphy is now available! Sheila Waters is not only a master scribe, but a master teacher. She has made both her life's work. For over 20 years of summer workshops, she took scribes though their paces for up to six weeks of in-depth instruction in letterforms (historical and modern) in Gaithersburg, Maryland. Students came as far away as Australia and Japan for these intensive classes. Throughout the rest of the year she taught and continues to teach many weekend workshops sponsored by calligraphy guilds throughout the USA and Canada. She is also a frequent instructor at the international calligraphy conference held each summer.

Her instruction provides the insightful analysis of forms and construction that take the mystery out of learning calligraphy. Her instruction helps you learn how to analyze a script on your own to help you toward mastery of an alphabet.

In the 126 pages of exemplar alphabets, instruction, and hints, Sheila shares with you the knowledge she has gathered over her years of study and practice. The presentation is honed by her experience teaching calligraphers how to advance their skill and art. These articles were first printed as a regular feature of *Letter Arts Review* between 1995 and 2000. They are edited and collected in this volume for the first time. Sixteen pages – eight in full color – of additional examples of Sheila's work are added to the original instruction.

Book Chapters:

- ✧ *Roman Minuscule: Foundational Hand*
- ✧ *Capitals*
- ✧ *Narrow Hands: From Roman Minuscule to Black Letter*
- ✧ *Loosening up Black Letter by Exploring Gothic Cursives*
- ✧ *Uncial & Half Uncial*
- ✧ *Carolingian*
- ✧ *Italic*
- ✧ *Italic: Creating Variations*
- ✧ *Analyzing Letterforms and Practicing Effectively*
- ✧ *Design & Layout*

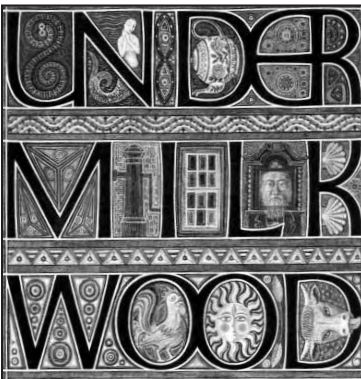

B1012. Under Milk

Wood: A Play for Voices by Dylan Thomas. 1989. 80pp. 9"x13". Hardcover **\$90.00**

Commissioned by a private collector in 1961 and completed in 1978, the 76 page manuscript is now exquisitely reproduced, each page in full color. The elaborate title page is embossed into the cover. Of the 26 illustrations, six are text column length. The script is Sheila Waters' personal style of Carolingian.

"This is a book to be cherished, one that will continue to delight for a very long time." – Penelope Kleespies

BP28. Roundel of the Seasons.

13"x13". **\$40.00**

Sheila Waters' delightful Roundel is available again! Full color, signed. *"The best print of the Roundel ever."*

– Sheila Waters



Gottfried Pott

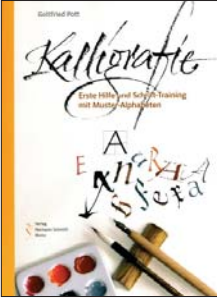

B2743. Kalligrafie: Erste Hilfe und Schrift-Training mit Muster-Alphabeten by Gottfried Pott. 2005. 112pp. 8-3/4" x 12". Paper **\$29.95**. While the text is in German, there are plenty of exemplar alphabets and examples of Pott's work to make it a valuable addition to your library. Includes Italic,

Roman, Carolingian, Uncial, a variety of Blackletter alphabets, brush and ruling pen writing. It beautifully designed and printed with many full color illustrations, but on a smooth, uncoated, off-white paper. A definite for Pott fans.



B2907. Kalligrafie: Intensiv-Training by Gottfried Pott. 2006. 136pp. 8.75"x12.25". Paper **\$37.50**

New This second instructional volume provides instruction on additional hands, explores experimental calligraphy, techniques of manual embossing and covers the cultural development of writing. Full of illustrations. Text in German only.

Annie Cicale

B2811. The Art & Craft of Hand Lettering by Annie Cicale. 2004. 192pp. 10"x10". Paper **\$17.95. JNB Price \$16.95**

Annie Cicale is well known to calligraphers throughout the USA and Canada from the many workshops and classes she has taught for guilds and at many of the summer

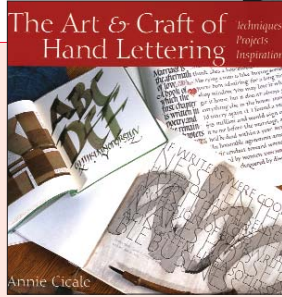

conferences. She now has a book with fine alphabets and good instruction. Exemplars include foundational, italic, roman, black letter, uncial, italic handwriting, pointed pen, brush lettering and ruling pen alphabets. She covers design and includes a generous gallery. Color throughout.



Historical Scripts

B135-H. Historical Scripts by Stan Knight. 1998. 112pp. 9"x12". Hardcover **\$39.95. JNB Price \$36.95**

sale A full page manuscript reproduction is accompanied by an enlarged detail

and Knight's discussion of the script. A much revised and enlarged edition of this valuable resource. Forward by Ewan Clayton. New & better photos of most of the enlargements. 12 new manuscripts are shown. The enlarged details are much improved. A great complement to Sheila Waters' *Foundations of Calligraphy* (B2769, \$35). See page 7.

See page 34 for index.

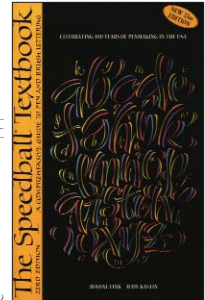

B039. The Speedball Textbook edited by Joanne Fink & Judy Kastin. 23rd ed. 1999. 96pp. 5.75"x8.5". Paper **\$9.99**

A worthy manual with alphabets and examples by leading calligraphers. Includes monoline roman, edged pen roman (S. Waters), foundational (Winters), versals (Wronker), knotted letters (Van Stone), uncial, Carolingian (S. Waters), blackletter (Dunham), gothicized italic (Marcy Robinson, Morentz), italic (Sheila & Julian Waters), copperplate (Caroline Paget Leake), Spencerian, Neuland, flat brush, pointed brush (Holliday & Reaves), italic handwriting, and Hebrew. Many examples of calligraphy and its uses. 16 full color pages! For beginner through advanced.

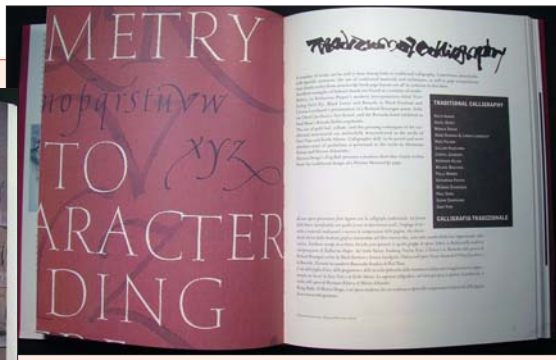

B2244. Belle Lettère.
1997. 168pp. 9.5"x12".
200 illus, almost all in
full color. Hardcover.
\$95.00

This full color book presents the best works from the entries for the Belle Lettère Prize. It is a glorious volume filled with full page and detail color shots of the calligraphic and expressive pieces. All are in full color. It is a painterly presentation printed on an off-white sheet, which gives the color reproduction a subtle warmth. Dust jacket and slipcase.

Contributors include Denis Brown, Jane Dill,

Belle Lettère

Jacobsen, Hermann Kilian, Werner Schneider, Brody Neuenschwander, Jan Owen, Paul Shaw, Susan Skarsgard. There are also many Europeans who are little known to American calligraphers. Introductory essays are by Carlo Buffa "So Far, So Close"; Thomas Ingmire "Calligraphy in the 20th Century"; Tiziano Santi "Between Word and Image"; and Manfredo Massironi "The Pleasure of Showing & Looking at Words." A final essay by Monica Dengo is on "The Work of Thomas Ingmire." Each essay is in English and Italian.

Please be warned. The f-word appears on pages 10-11. If the word gives you offense, don't purchase this book.

Ward Dunham
& Linnea
Lundquist,
Olive Bull, Glen
Epstein, Rose
Folsom,
Georgianna
Greenwood,
Thomas Ing-
mire, Cheryl

Letter Arts Review



LR19-4. LAR Wedding Issue.
2005. **\$17.50**

This special Wedding Issue is full of unique and engaging calligraphy for weddings – invitations, envelopes, reply cards, reply envelopes, and ketubbah.

Includes both traditional and innovative, formal and fun presentations. *Art: Larry Orlando*

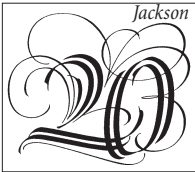

LR19-1. LAR Black & White Issue. 2004. 72pp.
8.5"x11". Paper **\$13.50**

This special issue includes over 150 works in black and white – in fact, the whole issue is a celebration of letterforms in black and white. Editor Rose Folsom has chosen lettering art that runs the gamut from stately & classically drawn letters to those freely written, complete with ink splats; from dense, textural pieces to light and airy compositions; varied in their approaches, but all showing a mastery of pen and brush. From approximately 600 entries, Rose chose over 150 superb examples from 15 countries.

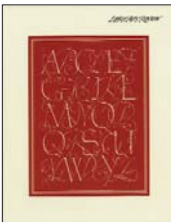

LR17-4. LAR Greeting Card Issue. 2003. 68pp. 8.5"x11".
Paper **\$16.50**

Features a wide selection of calligraphic greeting cards for Christmas, New Years, and other holidays. Includes printed and handmade cards, personal and commercial designs. 120 examples from 94 artists representing the USA and 12 other countries. Approx half in full color.

ANNUAL ISSUES

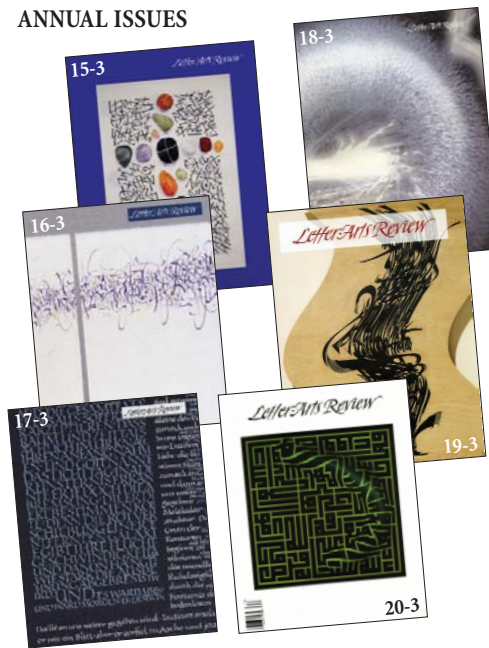

The annual best of calligraphy. Generally features 100 or more pieces from 50+ lettering artists from the USA & up to 13 other countries. Approx half the work is shown in full color. 64pp. 8.5"x11". Paper.
LR20-3. LAR 2005 Annual Issue. 2006. **\$17.50**
LR19-3. LAR 2004 Annual Issue. 2005. **\$17.50**
LR18-3. LAR 2003 Annual Issue. **\$17.50**
LR17-3. LAR 2002 Annual Issue. **\$16.50**
LR16-3. LAR Enigma Issue. 2001. **\$16.50**
LR15-3. LAR 2001 Annual Issue. **\$16.50**

Covers: 15.3 Nancy Leavitt, 16.3 Helga Ladurner, 17.3 Brigitte Schrader, 18.3 Denis Brown, 19.3 Carl Kurtz, 20.3 Mamoun Sakka
See page 58 for subscription information.





C51. New St John's Bible Card Portfolio.
\$11.95

New This second assortment of Saint John's Bible Notecards includes new work by Donald Jackson, Chris Tomlin, Suzanne Moore, and Sally May Joseph. 10 cards and envelopes. Includes 8 different full color designs taken from the illuminations in the Saint John's Bible. 4.75" x 6.75". Blank inside. Enclosed in nice paper portfolio.

DONALD JACKSON / SAINT JOHN'S BIBLE

The Saint John's Bible will be printed in seven volumes. Gospels & Acts, Psalms, Pentateuch are available now to ship. Prophets will be available in Jan/Feb of 2007. All are 9.75x15", hardcover, bound in red cloth and with a colorful dust jacket, 9.75"x15".

Purchase the entire set & save \$10 off the retail price of each volume. See: "Standing Order" below.

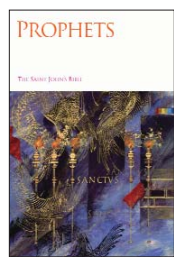

B2706. Saint John's Bible Prophets. Donald Jackson, Artistic Director and Illuminator. 2007. 232pp. 9.75"x15". \$69.95. **JNB Price \$59.95 through 1-31-07.** Available Jan/Feb 2007

New The fourth volume of The Saint John's Bible, *Prophets*, features some of the

most beautiful passages in all of Sacred Scripture. The ancient prophets of Israel suffered and celebrated with the people they both admonished and praised. They provided words of consolation during times of oppression and kept the flame of hope alive during the darkest periods of Israelite and Jewish history. Christians honor the prophets as those who foretold the coming of the Messiah.

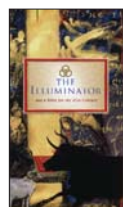

The Illuminator and the Bible for the 21st Century. \$18.95

The documentary of the making of the Saint John's Bible is now available on DVD (DVD30) and VHS (V30).

Donald Jackson and his staff used traditional calligraphic techniques with some modern twists in creating this 20th-21st century manuscript Bible. Ground pigments, egg yolks, gold, silver, and platinum are used in the illuminations. Goose quills and antique stick ink for the text. 49 minutes.

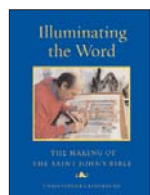

B2685. Illuminating The Word: The Making of the Saint John's Bible. 2005. 240pp. 9-5/8" x 11-3/8". Hardcover \$39.95

Covers the making of the first three volumes of the *St John's Bible: Gospels & Acts, Pentateuch, and Psalms*. There are many large images from the Bible itself, as well as actual-size samples of the scripts used.

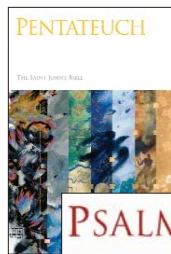

B2707. Saint John's Bible Pentateuch. 158pp. 9.75"x15". Hardcover \$69.95

New Pentateuch is composed of the first five books of the Old Testament (Genesis, Exodus, Leviticus, Numbers, and Deuteronomy) and is known as the Torah Judaism.

Illuminators: Donald Jackson, Chris Tomlin, Sally Mae Joseph, Suzanne Moore, Thomas Ingmire, and Hazel Dolby. Scribes: Donald Jackson, Brian Simpson, Sue Hufton, and Sally Mae Joseph.

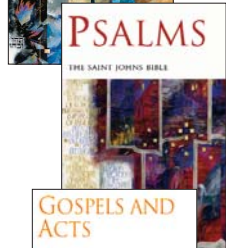

B2706. Saint John's Bible: Psalms. 136pp. 9.75"x15". 2006. \$59.95



B2679. Saint John's Bible: Gospels and Acts. Donald Jackson, Artistic Director and Illuminator. 2005. 136pp. 9.75x15. Hardcover \$64.95

The first volume in a seven-volume series of full-color, page-by-page reproductions from The Saint John's Bible. Gospels and Acts has more than 25 illuminations, including full-page opening illuminations for each of the four gospels.

Prices not yet determined

- B2708. Historical Books**
- B2710. Wisdom Literature**
- B2711. Letters & Revelation**

St. John's Bible Standing Order

Place a standing order for all remaining volumes of the Saint John's Bible and you can also receive \$10 off the retail price of any current volumes you purchase at the same time. If you have already purchased one or more volumes, you will receive the \$10 off the remaining volumes.

Visit johnnealbooks.com for these items:

B2911. Painting with Words: The Calligraphy of Donald Jackson. 1988. 26pp. 7x10. Paper \$20.00

New Essays by Christopher de Hamel, John Stevens, Ann Hechle, Guillermo Rodriguez-Benitez, and Kaz Tanahashi accompany eight color pages of Jackson's work

BP19. Painting with Words Poster. \$20 postpaid USA.

Moving? Send us your change of address. The post office will **NOT** forward our catalog to your new address.

Please see page 36 for ordering information, including shipping charges

B2787. The Bible of Illuminated Letters: A Treasury of Decorative Calligraphy by Margaret Morgan . 2006. 256pp. 5.75"x7.75". Spiral Hardcover \$24.99. **JNB Price \$22.50**

Step-by-step instructions for creating 12 illuminated alphabets including Celtic, Saxon, Gothic, Romanesque and Modern Revival. Both caps and minuscules are presented along with borders and decorations. Gilding is also covered. Gallery of historical and contemporary illuminated letters. More than 400 color illustrations.

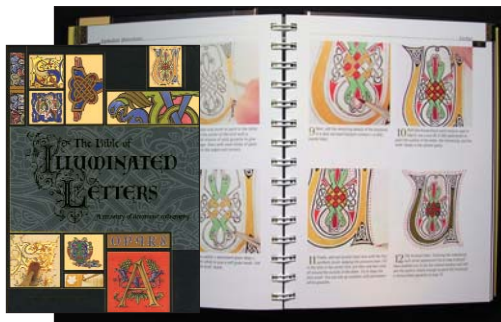

ILLUMINATION

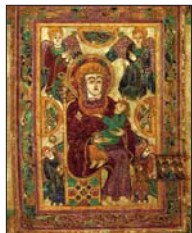

DVD31. The Book of Kells DVD-ROM. \$33.50

New Contains all 340 folios or 680 pages of the Book of Kells manuscript. A zoom feature allows you to examine fourteen richly illuminated pages in detail. In addition, a wealth of information is presented including: the Book's history, the scribes who created it, the materials used, the design systems of the day, the themes of the Book, details of animals, angels, monks and illuminated capital letters. Developed with the Library of Trinity College Dublin and is the only authorized digital version of the Book of Kells.

Book of Kells Screen Saver (CD13, \$9.95).

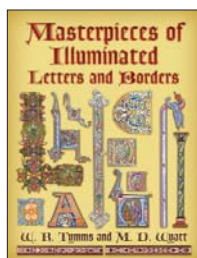

B2837. Masterpieces of Illuminated Letters and Borders by WR Tymms and MD Wyatt. 2006. 8.75"x11". Paper **\$14.95**

New More than 350 decorative designs including 256 letters. A wonderful selection from 19th century sources.

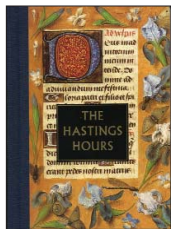

B2820. The Hastings Hours by Janet Backhouse. 1997. 64pp. 5"x6.75". Hardcover \$9.95.

JNB Sale \$3.99 Limited supply

sale A fully illustrated introduction to this late 15th century Flemish Book of Hours. Reproduces in full color 25 of the surviving 32 large illuminations – close to actual size. Also presents many decorative borders and details.

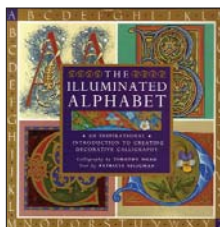

B2611. The Illuminated Alphabet: An Inspirational Introduction to Creating Decorative Calligraphy by Patricia Seligman. Calligraphy by Timothy Noad. 1994. 160pp. 9"x9". Paper \$14.95. **JNB Price \$14.50**

This how-to book about making illuminated letters presents: Celtic, Gothic, Romanesque, Renaissance, Modern Revival. Step-by-step illustrations for drawing, gilding, and painting these decorated letters.

This lush book is crisply printed in color throughout. For each initial letter, an initial from a manuscript is shown. A wonderful book!

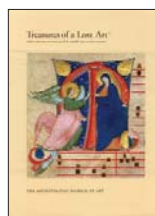

B2844. Treasures of a Lost Art: Italian Manuscript Painting of the Middle Ages and Renaissance by Pia Palladino. 2003. 204pp. 8.75"x11.5". Hardcover **\$24.95**

New Presents nearly 150 leaves, cuttings and illuminated manuscript fragments (169 illustrations many in full color). The scholarly catalog deals mainly with the history of these illuminations. Vivian Mungall finds it a great resource for illuminated initials.



CD11. Turning the Pages: The Collection. 2004. **\$39.95**

New This CD-ROM allows you to view approx 32 pages each from 12 great manuscripts. Each page has notes and

you can use your magnifying glass over the page to see the details! Manuscripts: Lindesfarne Gospels, Luttrell Psalter, Sforza Hours, Sherborne Missal, Golden Haggadah, Diamond Sutra, Sultan Baybars' Qur'an, Leonardo's Notebook, Vesalius's Anatomy, Blackwell's Herbal, Jane Austen's History of England, The Golf Book. A truly amazing CD!

Gilding Instructional DVDs

Instructional DVDs by Sally Mae Joseph (Sally Teague), one of the scribes working on the St John's Bible.

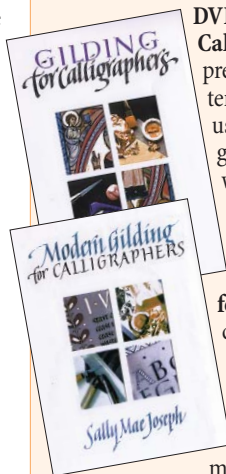

DVD14. Gilding for Calligraphers. Selecting and preparing vellum, slaking plaster and making gesso, gilding using loose leaf gold, preparing gum ammoniac and gilding with transfer gold, painting with shell gold and color. 130 minutes. **\$37.50**

DVD16. Modern Gilding for Calligraphers. Curing and cutting quills; using quills and metal pens on paper and vellum; writing with gesso; using brushes on fabric; combining traditional and modern sizes; and laying loose-leaf, transfer, shell gold, and platinum on vellum, paper & fabric. 70 minutes. **\$35.00**

HANDWRITING



B2371. Handwriting: Everyone's Art. Edited by Timothy Wilcox and Ewan Clayton. 1999. 8.5"x11". 63pp. Paper. **\$24.95**

Preface by Timothy Wildox, History of Learning to Write, Ewan Clayton; Two Journals, Sally Teague; Italic Handwriting in the 20th

Century, John Hash; Handwriting: Everyone's Art, Ewan Clayton. Plates from the exhibition: Fairbank, Irene Wellington, John Skelton, David Howells, Hermann Zapf, Ann Hechle, Donald Jackson, Stan Knight, David Mekelburg, Gerald Fleuss, Lindsay Castell, Jean Larcher, Jovica Veljovic. 63 illus., 10 in color.

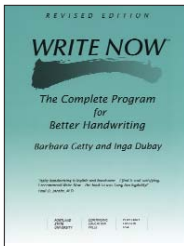

B1253. Write Now by Inga Dubay and Barbara Getty. 2005. 96pp. 8.5"x11". Paper **\$16.95**

A self teaching manual for a monoline italic based handwriting. Highly recommended. *Second edition.*

PAPERCRAFT/COLLAGES

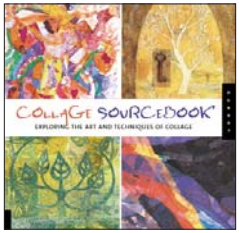

B2755. Collage Sourcebook: Exploring the Art and Techniques of Collage by Holly Harrison, et al. 2004. 272pp. 9.25" x 9.25". Paper \$25.00. **JNB Price \$22.50**

Dozens of techniques are demonstrated in visual step-by-step instructions. Materials range from paper to found objects. Includes photo transfer, gold leaf, encaustic, assemblage, photo montage, computer collage, fabric collage, cast-paper-pulp collage, tissue-paper collage, decoupage, painting and printing on paper, water soluble pastels, frottage, texturing/altering paper, and altering books.

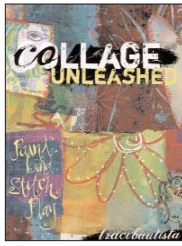

B2877. Collage Unleashed: Paint, Bind, Stitch, Play by Traci Bautista. 2006. 128pp. 8.5"x11". Paper \$22.99. **JNB Price \$20.99**

New Combines collage, altered fabric and journaling. The projects include art books, fabric journals and mixed-media paintings using paper, fabric, beads, dyes, paints & more. Techniques include crayon transfers, funky embroidery, and bookbinding.



B2807. Paper Engineering: 3D Design Techniques for a 2D Material by Natalie Avella. 2006. 160pp. 9"x10.25". Paper \$30.00. **JNB Price \$27.50**

New This full color book presents a gallery of commercial works using innovative folds, cuts and bindings. It's targeted to graphic designers, but is equally interesting and inspiring for those who do artists books and those who love to make innovative structures. There are holiday cards, invitations, promotional leaflets, business cards and more. Includes both work for clients and work for self. For most there is info on the piece and its production process

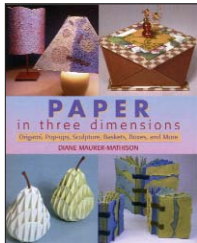

B2841. Paper in Three Dimensions: Origami, Poppers, Sculpture, Baskets, Boxes, And More (Paperback) by Diane Maurer-Mathison. 2006. 128pp. Paper \$19.95. **JNB Price \$18.95**

New Covers origami, elegant pop-ups, paper sculpture, cast and richly textured handmade papers, dimensional sculpture, and boxes and baskets. Each is presented with projects accompanied by fully illustrated step-by-step directions.

Visit johnnealbooks.com for these and more books:
B2899. The Art of Paper Jewelry. 2006. 128pp. \$24.95
JNB Price \$19.95

Paste Papers



B2504. The Art of Making Paste Papers by Diane Maurer-Mathison. 2002. 112 pp. 8-1/2"x10-1/2". Paper \$21.95. **JNB Price \$19.95**

Demonstrates step-by-step how to create beautifully patterned papers – from preparing the papers and applying the paste, to producing combed, textured, stamped, and even hand-drawn designs. Includes how to use paste papers to make scrapbooks, greeting cards, picture mats, boxes, and

other projects as well as a gallery of dazzling works by an international roster of paste paper designers.

Use these tools for making designs on paste paper.

S335. Paint Scrapers. 4 plastic scrapers **\$6.95**

S336. Triangular Scraper. Flexible blue rubber. 3 sides, 3 designs. **\$5.95.**

Arches Text Wove – a super paper for paste paper, see page 38.



See 20 for Wheat Starch for Paste & Methyl Cellulose.

S336.



Robert Sabuda

B2601. Alice's Adventures in Wonderland by Lewis Carroll. Illustrated by Robert Sabuda. 2003. 12 pop-up spreads. 7"x10". Hardcover \$26.95. **JNB Price \$24.95**

While paying homage to the original illustrator Sir John Tenniel, Sabuda uses vibrant colors, thick black outlines, and foil to create a work that is uniquely his. The bizarre settings and creatures of Wonderland burst out on every page, starting with an ingenious peep-show rabbit hole and ending with an explosion of cards.

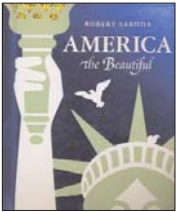
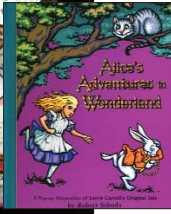

B2659. America the Beautiful by Robert Sabuda. 2004. 14 pop-up spreads. 8"x10". Hardcover \$26.95. **JNB Price \$24.95**

Robert Sabuda's highly anticipated tribute to America is now available! "America the Beautiful" is a stunning pop-up version of the classic poem which celebrates the great diversity of our nation. "America the Beautiful" contains 10 pop-ups including special effects like the amazing turning wheel of a paddleboat as well as multifaceted foil, making this book a must-have for any collector!

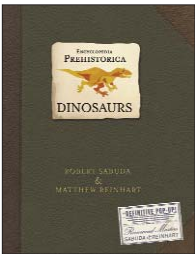

B2754. Encyclopedia Prehistorica: Dinosaurs by Robert Sabuda & Matthew Reinhart. 2005. 8"x9.75". Hardcover. \$27.99. **JNB Price \$25.95**

Over 35 of Sabuda's amazingly complex pop-ups. A massive T. Rex that springs out, a reptile raptor that unfurls and appears to fly, "shield-bearers" in full body armor, creatures with frilly headgear, and weighty, long-necked giants. Includes current info on more than 50 dinosaur species.

Six multi-layered spreads each feature one spectacular, large pop-up and several booklets of smaller pop-ups and text.

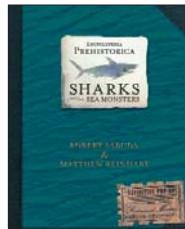

B2842. Encyclopedia Prehistorica Sharks and Other Sea Monsters: The Definitive Pop-Up by Robert Sabuda & Matthew Reinhart. 2006. 8x9.75 Hardcover \$27.99. **JNB Price \$25.95**

New Another book of their trademark complex pop-ups that almost defy belief. Add this to your collection!

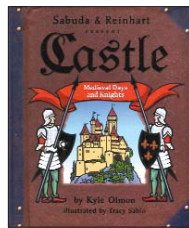

B2885. Sabuda & Reinhart Presents: Castle by Kyle Olmon, Illustrated by Tracy Sabin. 2006. 12pp. Hardcover \$19.99. **JNB Price \$18.99**

New Over fifteen intricate pop-ups accompany Sabuda and Reinhart's fascinating text, which guides readers through the different aspects of life in a medieval castle. Readers will learn about knightening ceremonies, battles, and feasts. The true majesty of castles is fully realized when this book is opened to reveal a stunning 3-dimensional medieval world. For children 9-12 and adults of all ages!

Visit johnnealbooks.com for these and more books:

B2337. The Movable Mother Goose by Robert Sabuda. 1999. 7"x10". 6-Spreads. Hardcover. \$21.95

B2529. The Wonderful Wizard of Oz: A Commemorative Pop-up by Frank Baum and illustrated by Robert Sabuda. 2001. 16pp. 10.5"x8.5". Hardcover \$26.95. **JNB \$24.95**

Sabuda Christmas

C52. Christmas Alphabet Cards by Robert Sabuda. \$24.95. **JNB \$22.50 2+ \$21.50 each.**

New

A set of 26 pop up Christmas cards, one for each letter of the alphabet. The beautiful designs are based on his book *The Christmas Alphabet*. The pop-up constructions are in white against a colored card background. Greeting: Seasons Greetings. Includes 26 envelopes and is packaged in a metal tin! I'm planning on a rotating display on my fireplace mantel!



B2884. The 12 Days of Christmas Anniversary Edition: A Pop-up Celebration by Robert Sabuda. Hardcover \$26.95. **JNB price \$24.95**

New

Each verse of "The 12 Days of Christmas" has a spread. Brightly colored backgrounds serve as the base for the snow-white pop-ups – some relatively simple, others spectacularly intricate. A second pop-up for each verse is hidden under a gatefold panel.

B2778. Winter's Tale: An Original Pop-Up Journey. \$26.95. **JNB price \$24.95**





Tim Botts

C47.

C47. Botts Boxed Notecards. Colorful, expressive calligraphic renderings of scripture. Tim Botts has selected his most popular designs for this set of 12 different cards with envelopes. 5x7. Blank inside. **\$12.50**

Special offer: Order two or more Botts items and the cards are only \$11.00 per box.

B2447. Portraits of the Word by Timothy Botts. 2002. 165pp. 7"x8". Hardcover **\$18.99**

Includes 75 verses from Bott's Bible. Along with the colorful verses, there are screened back images of his preliminary sketches as well as his comments on the artistic process. He also shares prayers written in response to his artistic encounters with God.

Visit johnnealbooks.com for more info:

B2217. The Book of Psalms. 1997. 160pp. 8.5" x 10.75". Hardcover **\$25.00**

B050. Doorposts Hardcover **\$19.99**

LETTERING

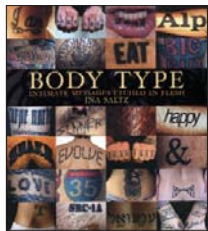

B2874. Body Type: Intimate Messages Etched in Flesh by Ina Saltz. 2006. 192pp. 7.25"x8.25" Hardcover **\$19.95**

New

A stunning photographic collection of typographic tattoos with commentary on the letter-

forms by Saltz and personal recollections of the tattooed on the motivation for their chosen words. Included are several anagram tattoos designed by John Langdon, author of *Wordplay*.

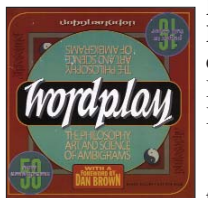

B2777. Wordplay: The Philosophy, Art, and Science of Ambigrams by John Langdon. 2005. 224pp. 8"x8." Paper **\$14.95**

New

Ambigrams are a visual lettering trick. You turn the lettering

upside down and the word reads the same! This updated collection of ambigrams features a section of full-color ambigrams and dozens of mind-bending examples of this cryptic art form. Many involve full circles of lettering. Each ambigram is accompanied by a short essay, some serious, some witty. This revised edition includes 50 new examples!

2007 CALENDARS

CL2307. Jean Formo's 2007 Desk Calendar. The Year of Our Lord. 5.75"x8". **\$7.95**

New

Jean has provided 56 full color calligraphic compositions. These spiritual reflections are taken from the Bible, spiritual writers and folk wisdom. Each piece reproduced is done by hand with nibs, colored pencils, ink and paint (without any computer help!). This is Jean's third engagement (desk) calendar. This one is perhaps more strongly Christian than previous years.

Quantity Prices: 2-4 \$7.85ea, 5-9 \$7.55ea, 10-19 \$7.25ea, 20+ \$7.15ea

CL2607. The Biblical Year Wall Calendar 2007. 12"x12". **\$12.95**

New

Tim Botts' colorful and expressive calligraphy on a Wall Calendar! Each year images are chosen from his books and often reproduced larger than originally published. A great gift!

DESIGN



B2346. Design Language: Interpretive Edition by Tim McCreight. 2006. 136pp. 8.5"x8.5" Paper **\$22.50**

New

Takes 60 words commonly used to discuss the design of objects – such as decorative, density, design, dialogue, dominance & dynamic. Provides definitions in three forms: brief design dictionary one, expanded comments, and striking visual examples of fine craft / folk craft that illuminate the term. It is a beautiful and useful book

ADOLF BERND



LR-7.2. Letter Arts Review (Adolf Bernd) Vol 7, No 2. 8.5"x11". 64pp. **\$11.00**

Peter Thornton has been introducing this German lettering artist's work at summer conferences and at workshops. His watercolors combine letters with panels of nuanced color. This regular issue contains an 8-page article on Bernd's work accompanied by 10 examples, 5 in full color.



January	
Number	15
Month	16
Weekday	17
Wednesday	18
Thursday	19
Friday	20
Saturday	21

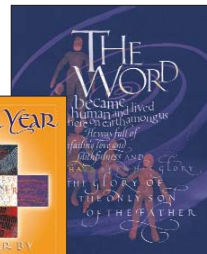
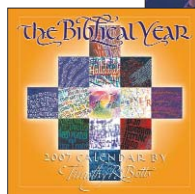

Correspondence

Many of us still treasure written rather than electronic communication. Here are some delightful examples of letters and envelopes.



B2806. Envelopes: A Puzzling Journey Through the Royal Mail by Harriet Russell. 2005. 96pp. 8.25"x8.25". Hardcover \$16.95. **JNB Price \$15.50**

This book from the UK presents a collection of a most curious and diverting collection of decorated envelopes, all of which have been sent through the Royal Mail system. The designs include mazes, join the dots, anagrams, illustrations, puns, visual games, experimental fonts, puzzles, and literary wordplay. While Russell is not a calligrapher, her envelopes are delightful & fun. They are often more puzzles than works of art.



B2810. The Pony Express. 2005. 30pp. 7.25"x8.5". Paper \$16.95

Displays all the envelopes sent by participants to Legacies, the summer 2005 conference. One of the most popular displays at each conference are these envelopes; many are the result of hours of work. This is the first time a booklet of the envelopes has been published. Includes 146 envelopes from 124 artists. All in full color. An innovative collection.

B2824. Hand Illustrated Postal Envelopes \$14.99

LR20.4. Correspondence Issue. 2006. 64pp. 8.5"x11. **\$13.50**

New This special issue of *Letter Arts Review*

includes: the protocol of letter-writing in Renaissance England, Ewan Clayton on handwriting, Alan Blackman's First Day Envelopes, Ward Dunham's calligraphic postcards, seals and sealing wax, Lily Wronkers' collection of calligraphic stamps, and The Graceful Envelope.

B2773. Graceful Envelope Scripsit 2003-05. 2005. 8.5"x11". 24pp. Paper \$20.00

New Features full-color reproductions of more than 50 of the winning envelopes from 2003 through 2005. The envelopes incorporate each year's theme in a creative and artistic way, using hand-executed calligraphy or fine lettering to address the envelope. Many feature inventive relationships between the postage stamp, the envelope design and the lettering. It's an inspiring collection.

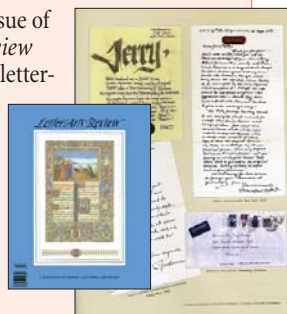

Sealing Wax



Atelier Gargoyle Sealing Wax. Ward Dunham and Linnea Lundquist have produced a new sealing wax in a range of 10 beautiful colors. Each stick is graced with Ward's bold black-letter in high relief. Their wax is almost Post Office proof. Unlike other sealing waxes, it remains flexible when it hardens and

sticks tight to paper. It allows you to mail a wedding invitation or other correspondence with a seal on the outside of the envelope. The sticks are made from a combination of natural waxes and synthetic polymers. These sticks remain soft a bit longer giving you more time to shape your wax and make your impression. Each has a subtle scent.

New **S560-XXX. Atelier Gargoyle Sealing Wax Sticks.** Specify colors: Red, Green, Gold, Silver, Copper, Burgundy, Silvery Turquoise, Eggplant, Purple Passion, Royal Blue. **\$6.00 each.** 5/\$5.50 each 10/\$5.00 each.

S561. Traditional Set. One each of Red, Green, Gold, Silver and Copper. **\$25.00**

S562. Color Set: One each of Burgundy, Silvery Turquoise, Eggplant, Purple Passion and Royal Blue. **\$25.00**



S429. Square ABC Inkwell. A porcelain reproduction of a classic French 1920's glass school inkwell. Pen rests around the neck, loose stopper with logo, elegant script alphabet in red wrapped around base. Beautiful gift box. Popular at Celebration conference. **\$11.99**



New **S549. Round Porcelain "Write" Inkwell.** 2" dia x 2.75"H. Gift Box. **\$11.99** A diminutive French style limoge traveling inkwell. Hinged lid. Simple, yet elegant with the word "write" and "&" (ampersand).

S555. MicroGlaze. Use to protect calligraphed envelopes, to preserve the surface of marbled or decorative paper. Applied thinly with finger to make surface water resistant. Non toxic, acid free. 4oz. **\$8.50**

S576. Hot Stick Holder. This is perfect for holding your sealing wax stick while you make the impression. Stainless Steel. **\$10.00** 2/\$9

S236. Envelopes Please. Set of 3 envelope templates and a bone folder. **\$14.50**

Zapf

B2430 Calligraphic Type Design in the Digital Age: An Exhibition in Honor of the Contributions of Hermann & Gudrun Zapf. Edited by John Prestianni. 2001. 204pp. 8.5"x11". Hardcover \$49.95 **SALE \$29.95 while supplies last.**

sale This is the catalog to the exhibition which also features the work of 14 other calligrapher/type designers who have been influenced by the Zapfs' work including: Robert Slimbach, Alan Blackman, Rick Cusick, Jean Evans, Jacqueline Sakwa, Phill Grimshaw, Akira Kobayashi, Jovica Veljovic, Viktor Solt, Julian Waters, & Richard Lipton. 100 clr / 90 b&w illus.

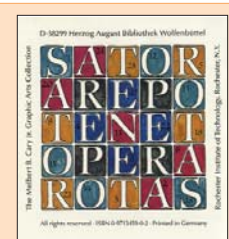

CD09. CD-ROM. The World of Alphabets:

A Kaleidoscope of Drawings and Letterforms. 200 color digital reproductions of works spanning the past 60 years of Zapf's career. Selected typeface sketches, calligraphic exemplars, broadside layouts, book designs and previously unpublished pieces from Zapf's personal archive. For PC or MAC OS9. **\$50.00**

Visit johnnealbooks.com for more info:

B2471. Gudrun Zapf. \$75.00

John Stevens



B2362. The Character: Selected Works, Calligraphy, Drawings, Paintings 1990-1999. 2000. 33pp. 6"x9". Paper **\$20.00**

Features over 30 pieces of John Stevens' remarkable work including quotes, alphabets, and pieces incorporating paintings & drawings. Stevens states in the opening comments that he hopes to "create visual poetry." The works in this book are visual poetry, uniting meaning and presentation beautifully. Comes with a bookmark-style guide with the title and tools used for each piece. Full color throughout.

Visit johnnealbooks.com for John Stevens' t-shirts.

New C54. Proverbial Cat Card Collection.

16 delightful color note cards that combine Sydney Hauser's calligraphy and cat illustrations. The brief text on each will resonate with all cat owners. 2 each of 8 designs in a box. 18 envelopes. **\$12.00**

C38. Proverbial Cat Cards. Eight cards / envelopes. Two of each design. **\$6.00**

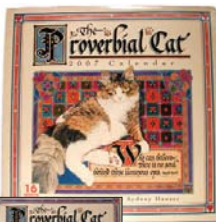

CL2107. The Proverbial Cat 2007. Wall Calendar. 12"x12". **\$12.99**
Full color. Sydney Hauser's cats and calligraphy illustrate for us a collection of maxims, proverbs and adages. Charming!



CL2107-M. Proverbial Cat Mini Calendar 2007. 7"x7". \$6.99

The mini is a smaller version of the popular Proverbial Cat Calendar. A great small gift for cat lovers. Images are different from the full size version.

Shambhala Calligraphy

This wonderful series explores cultures through calligraphy. In these colorful little books, each two page spread presents a text in English and the calligraphic expression related to the text.

Each full-color book a introduction on the text and a longer section written by the calligrapher on the script & calligraphic expressions. Text in English.

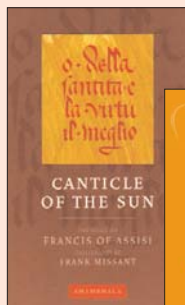

B2524. Canticle of the Sun. 2002. 62pp. 5"x8.5". Paper \$12.95. JNB Price **\$6.50**

The Spirit of Francis of Assisi. Calligraphy by Frank Missant. In Latin. *Limited supply.*

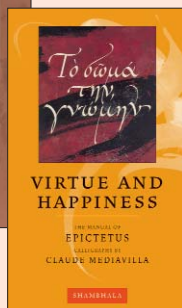

B2544. Virtue and Happiness: The Manual of Epictetus by Epictetus. 2003. 64pp. 5"x8.75". Paper. \$12.95 JNB **\$6.50**

Calligraphy by Claude Mediavilla. Text in English, calligraphy in Greek.

WALNUT INK



B2750. Walnut Ink: Fabulous Techniques and Dozens of Ideas for Cards, Books, Scrapbooks, Photos and More by Beverly Seymour. 2004. 34pp. Paper **\$12.99**

Use the ink made from walnut crystals. This how-to book covers washes, dilution formu-

las, aging objects and paper, enhancing embossed paper, applying walnut ink to b&w photocopies, creating custom papers and more. Full of color photos of finished projects.

S449. Walnut (Color) Ink Crystals. Add distilled water, wait for 25-35 minutes and this powder produces a warm, rich walnut-colored ink. The ink is lightfast, flows well and is highly recommended by many master scribes

1 oz. \$3.50, 2 oz. \$4.50, or 4oz. \$7.50

ALTERED BOOKS

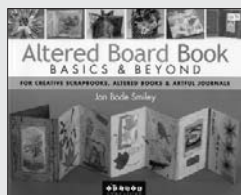

B2723. Altered Board Book: Basics & Beyond by Jan Bode Smiley. 48pp. 2005. 10"x8". **\$12.95**

Instead of using paper for pages, board books use binders

board. This book provides instruction on backgrounds: textures, painted, paper and fabric. As well as creating niches for objects. Includes gallery of accordion and codex forms. The techniques can be used to alter printed children's books and to decorate blank books you construct or purchase readymade.

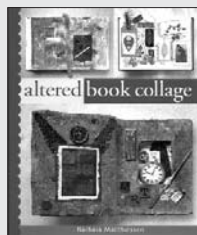

B2726. Altered Book Collage by Barbara Matthiessen. 2005. 144pp. 9"x10.5". Paper **\$14.95**

After an introduction to altered books and a presentation of techniques, this book presents scores of examples of covers and interior pages. Brief instructions are given for each of the pages displayed. The great variety is sure inspire you. Full color throughout.

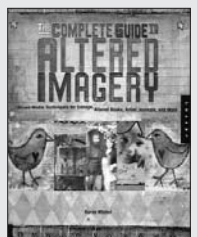

B2774. The Complete Guide to Altered Imagery: Mixed Media Techniques for Collage, Altered Books, Artists Journals and More by Karen Michel. 2005. 128pp. 8.5x11. Paper **\$21.99**
JNB \$19.99

Learn how to manipulate actual photographs, how to use your scanner and printer to create and alter digital images, how to use art materials and collage techniques to produce altered images, integrating found objects, image transfers, and using traditional printmaking techniques. The last section is a gallery of 20 works by a variety of artists. Over 150 full color images to inspire and instruct! The first printing quickly sold out!

Visit johnnealbooks.com for these and more books:

B2639. Altered Books Workshop. Brazelton. 2004. 128pp. 8.5"x11". Paper \$19.99. **JNB \$15.99**
B2668. Altered Art. Taylor. \$19.95 **JNB \$17.95**

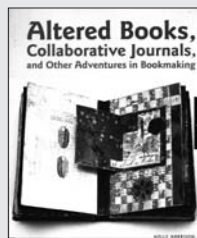

B2597. Altered Books, Collaborative Journals, and Other Adventures in Bookmaking by Holly Harrison. 2003. Paper **\$21.99**. **JNB \$19.99**

Explores the creative processes behind "altered books" – when artists make their own distinctive mark on an already published work – and "collaborative journals" – in which many artists come together to create a unique single work. Readers will learn how to alter books through collage, paint, layering, sewing and more. Filled with easy, how-to projects and beautiful gallery photos.

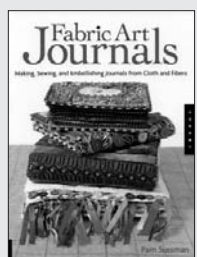

B2797. Fabric Art Journals: Making, Sewing, and Embellishing Journals from Cloth and Fibers by Pam Sussman. 2005. 144pp. 8.5x11. Paper **\$21.99**. **JNB \$19.99**

Covers fabric journal basics, embellishing fabric journals, fabric book projects (with templates) & a 24-page gallery of fabric books. Embellishing includes Tie-dyeing & painting fabrics, adding words, image transfers, appliqué, quilting, embroidery, eyelets, buttons, beads, trims, & fancy edges & closures. Projects include simple bindings (muslin, concertina, button bound), intermediate (tape-bound, French-stitch, house box) and advanced (Coptic bound, dream).



B2798. Visual Chronicles: The No-Fear Guide to Creating Art Journals, Creative Manifestos and Altered Books by Linda Woods and Karen Dinino. 2006. 128pp. 9"x9". Paper **\$22.99**. **JNB Price \$21.50**

New With practical advice, humorous insight, and inspiring projects this book will encourage you to chronicle your thoughts and life with painting, sketching, stamping, collaging, and writing. It includes time saving tricks, clever prompts for writing and journaling, composition secrets, and step-by-step projects you can personalize to make visual journaling part of your routine. Each chapter starts by debunking a journaling myth, such as "I am not artistic."

TRADITIONAL BOOKBINDING

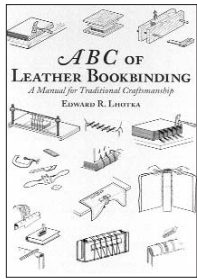

B2687. ABC of Leather Bookbinding: A Manual for Traditional Craftsmanship by Edward R Lhotka. 2000. 142pp. 7"x10". Paper **\$19.99**

An illustrated manual that shows step-by-step the art, craft and science of fine leather bookbinding. The author learned the craft from one of England's foremost

binders, Alfred de Sauty. Lhotka takes you through the intricacies of traditional leather binding.

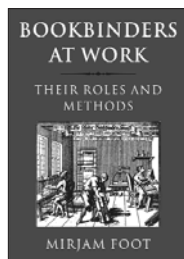

B2905. Bookbinders at Work: Their Roles and Methods by Mirjam Foot. 2005. 162pp. 7"x10". Hardcover **\$59.95**

New Presents the role of the bookbinder in the production of saleable books and the significance of the binding in all its details, both structural and decorative.

This lucid and very detailed description of binding practice is based on primary sources, manuals and descriptions of bookbinding practice of the 16-18th centuries in France, Germany, Netherlands and Britain.



B2751. Bookbinding Materials and Techniques 1700-1920 By Margaret Lock. 2003. 160pp. 5.5"x8.75". Paper **\$30.00**

Describes each step in hand binding a book and explains the practical and aesthetic considerations that influenced these techniques. Shows how all of these processes changed over

the 18th and 19th centuries due to mechanization, specialization within the trade, the vagaries of taste, the availability and cost of materials, and developments in printing, publishing, and book selling. Includes Canadian, European and American examples. 122 black and white illustrations. Revised and much expanded version of Two Centuries of Bookbinding: Materials and Techniques 1700-1900.

B2533. The Repair of Cloth Bindings: A Manual by Arthur Johnson. 2002. 116pp. 6"x9". Hardcover **\$35.00**

Using more than 90 illustrations, explains – in precise detail – procedures for the repair and reconstruction of cloth bindings. Includes brief history of cloth as a binding material.

Visit johnnealbooks.com for these and more books:
B2686. ABC of Bookbinding. Greenfield. \$39.95

B2740. Bookbinding and Conservation by Hand by Laura S Young. 273pp. 7"x10". Paper **\$24.95**

See page 33 for info on *Bound & Lettered*, the quarterly journal of calligraphy, bookbinding, & papercraft.

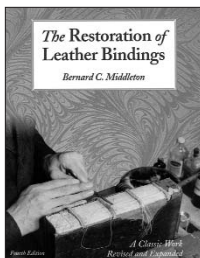

B2688. The Restoration of Leather Bindings by Bernard C Middleton. 2003. 326pp. 8.5"x11". Hdcvr **\$45**

Revised and expanded 4th edition. A comprehensive handbook for practitioner and student. Includes definition of terms, tools, materials, cleaning, and all phases of reconstruction. New addition is a full color section for the identification of leather and marbled papers. Updated listing of binders' suppliers. Well illustrated.



B1675-P. Headbands: How to Work Them by Jane Greenfield and Jenny Hille. 2001. 96pp. 6x9. Paper **\$14.95**

This easy to use, step-by-step guide shows how to create 14 different styles of headbands. Illustrated with numerous line drawings.

Order \$100 of Bookbinding books, and you can request a **FREE COPY** of B1675-P. Headbands.



B2794. A History of English Craft Bookbinding by Bernard Middleton. 1996 (2000) 372pp. 4th edition. Hardcover **\$55.00**

New The classic reference on decorative and commercial English bookbinding techniques by one of the foremost experts on bookbinding. Both techniques and historical info is given for leaves and folding, beating and pressing, sewing endpapers, gluing the spine, rounding and backing, boards and their attachment, edge-trimming and decoration, headbands, back linings, covering, finishing siding and pasting down, equipment, book repairs and restoration. Also includes the early 19th century London bookbinding trade, specialization in book-edge gilding, the Arts & Crafts movement & bookbinding styles, and the causes and prevention of leather decay. Excellent background for the English technique.

Bookbinding Instructional DVDs

DVDs of the demonstrations at Bookbinding 2000 are now available. **\$40.00 each**

DVD17. Michael Wilcox: Gold Tooling.

DVD18. Don Etherington: Fully Dressed in Leather, Conservation Style.

DVD19. Monique Lallier : Edge-to-Edge Doublure.

DVD20. Anthony Cains : A Decorative Leather Covering Technique.

DVD21. James Brockman : The Concave Spine.

DVD22. Louise Genest: The Exposed Spine Binding.

Visit johnnealbooks.com for details.

ARTISTS' JOURNALS

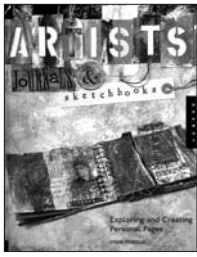

B2638. Artists' Journals and Sketchbooks: Exploring & Creating Personal Pages by Lynne Perrella. 2004. 128pp. 8.5"x11". Paper \$21.99. **JNB Price \$19.95**

An exciting full color gallery of personal pages by 40 artists including Joceyln Curry, Sue Nan Douglas, Lisa Englebrecht, and Connie Newbanks. Perrella presents information on working with photo copies, adding color to pages, image transfers, using photographs, slide mount artwork, attachment techniques, and adding text to pages. If you liked Gwen Diehn's *The Decorated Page* you'll enjoy this book.

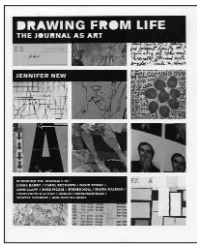

B2729. Drawing From Life: The Art Of The Journal by Jennifer New. 2005. 192pp. 8x10. Paper \$25.00. **JNB Price \$23.95**

Exploration of diaries of insight and visual beauty. These wonderful books are filled to their borders with drawings, sketches, watercolors, graphs, charts, lists, collages, portraits, and photographs. The "journalists" include an architect, a traveler, film director, archeologist, cancer patient, songwriter, quiltmaker, gardener, artist, cyclist, and scientist. They illustrate the broad range of journaling styles and techniques.

Visit johnnealbooks.com for these and more books:
B2650. Signatures: The Art Journal Collection. 2004. 176pp. 8.5"x11". Paper \$19.95

BOOKBINDING

B2801. The Art of Contemporary Bookbinding by Jan Van Der Marck. 1997. 137pp. 8"x10.75". Paper \$52.00 Presents essays on the binders (Leroux, Mathieu, De Gonet, Lobstein, Robinson, Glaister, Ely & Mowery) and on their designer bindings. 64 binding in full color. Text: English & Dutch.

How-to/Reference

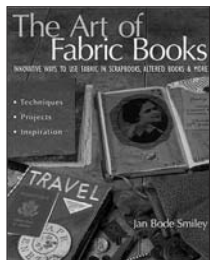

B2693. The Art of Fabric Books: Innovative Ways to Use Fabric in Scrapbooks, Altered Books & More by Jan Bode Smiley. 2005. 112pp. 8.5x11". Paper \$21.95
Seamlessly blends fabulous fabrics with altered books for cutting-edge designs.

Teaches how to use fabric as a natural addition to book and altered book projects, and for books made entirely of fabric and embellishments. These are creative, doable projects that use paper, fabric, thread, findings, buttons, and more in a variety of book styles.

B1863. Books, Boxes & Wraps by Webberley and Forsyth. Author working on revised edition. *If you place this book on your order – when the book becomes available again – you will be contacted with the new price and to see if you still want the book.*



B2033. Cover to Cover: Creative Techniques for Making Beautiful Books, Journals & Albums by Shereen LaPlantz. 1995. 144pp. 8.75"x10.25". Paper \$16.95. **JNB Price \$15.95**

A how-to book combined with a gallery of work. It has step-by-step instructions & illustrations, and they are accompanied by more than 170 photos of examples of finished books by a variety of book artists. Includes simple pamphlets, traditional codices, complex fold books, and many others. A bestseller. Full of non-traditional bindings.

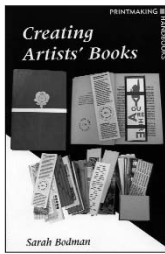

B2763. Creating Artists' Books (Printmaking Handbooks) by Sarah Bodman. 2005. 128pp. 6"x9.25". Paper \$19.95. **JNB Price \$18.95**

New A practical guide for visual artists who are interested in producing their work in the artist's book format. Examines history, methods and practicalities involved in making an artist's book, using many examples of the work of contemporary artists as illustration.



B2657. How to Make Handmade Books if You Think You Can't by Patty Grass. 2004. 96pp. 8.5"x11". Paper \$14.99

Provides instruction for 15 different books including: case-bound journal, circle accordion book, long stitch book, flutter accordion book, four needle book, French stitch book, Japanese stab binding, simple accordion book, single sheet accordion books, & triangle accordion book. Full of clear step-by-step photos, illustrations & instructions.

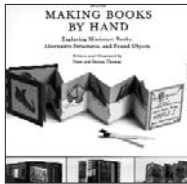

B2669. More Making Books by Hand: Exploring Miniature Books, Alternative Structures, and Found Objects. Written and illustrated by Peter and Donna Thomas. 2004. 144pp. 9.5"x9.5". Paper \$18.99. **JNB \$16.95**

The first 50 pages are a primer on book making. The rest of the book covers step-by-step instructions and illustrations on 12 book structures invented and perfected by the authors. Over 100 full-color photos of the projects and variations.

Visit johnnealbooks.com for more info:
B2752. The Art of the Book 03'. Paper \$20.00
B2464. Unique Handmade Books. Paper. \$17.95

See pages 2-4 for more Bookbinding & related books. For Bookbinding supplies, see pages 20-21 & 61-63.

CHERRYL MOOTE

B2765. Books with Girth by Cheryl Mootte. 2005. 220pp. 8-1/2" x 11". Paper \$45.00

This instruction manual covers books that have thick spines. Included are sewn books like coptic, longstitch and Secret Belgian Binding and many unsewn books like piano hinge, interlocking signatures, and the Spectabular book. The instructions are detailed and accompanied by clear diagrams, suggestions for variations and photos of the projects. The fifth in her bestselling series of instructional manuals.

BOOKS WITH GIRTH
CHERRYL MOOTE

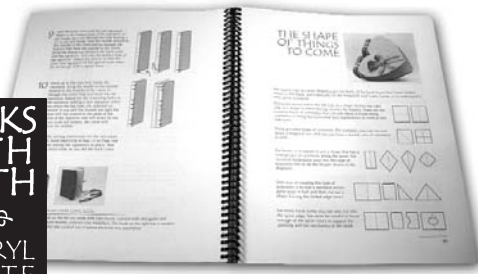

Cherryl tests each set of instructions with a group of papercrafters. For most there are no color illustrations, just pages of binding projects with good instructions. They have received rave reviews.

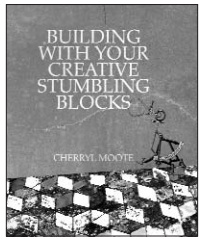

B2870. Building With Your Creative Stumbling Blocks by Cheryl Mootte. 2006. Approx 100pp. Paper \$35.00

New Shows how to make use of your creative blocks through exploring simple bookbinding, paper crafting and journaling. Explores creativity, creative growth and discovery with practical activities. Deal with your creative challenges and feel more in control of your creative path. Included in the book are sections on critical voices, setting goals, rediscovering your creative voice, finding time for creativity in your daily life and dealing with the fears and challenges of living a creative life.

COPIED, BOUND & NUMBERED
BY CHERRYL MOOTE

B2582. Copied, Bound & Numbered by Cheryl Mootte. 2003. 90pp. 8.5x11". Spiral

Paper \$29.95

This book features book forms perfect for creating small editions of art books with your photocopier or computer printer. The book forms presented also make wonderful one-of-a-kind books. Detailed instructions for the book forms and tips to help you streamline the assembly of the books, which leaves you more time to create art. Standard size papers are used for most projects.

Adhesives

Jade 403. Highly recommended PVA adhesive for bookbinding. pH neutral. **S340-8. 8oz \$6.60**
S340-16. 16oz \$11.95

S203. "Yes!" Stickflat Glue. For long-lasting archival mounting. Neutral pH. Will not react with air against paper. Completely organic, can be thinned with warm water. Ideal for conservation of art & bookbinding. Pint (16 oz.). **\$11.95**

S233. Wheat Starch for Paste. Pre-cooked, dissolves easily in cold water. Can also be mixed with PVA adhesives or methylcellulose. Used for attaching paper to boards, leather to covers & in tissue repairing. Wheat starch does not yellow. Also used for paste paper. Archival. 1 lb bag. **\$5.50**



B2605. Paper Delights by Cheryl Mootte. 2004. 124pp. 8.5"x11". Spiral Paper \$35.00

Features card, paper folding & bookbinding ideas for papercrafters who want to showcase chiyogami, scrapbook, hand decorated, paste, and hand decorated papers. Projects include dry embossing, iris folding, bargello, basic paper quilting, rotating cards, origami inkwell, origami kimono and happi coat, a bookmark, a takeout box full of paper fortune cookie books and a miniature library in a folded slip case. 3 pages of color.

V28. Paper Delights by Cheryl Mootte. 2004. 60 minutes. VHS \$29.95

SIMPLY BOUND
BEGINNINGS IN BOOKBINDING

B2429. Simply Bound: Beginnings in Bookbinding by Cheryl Mootte. 2001. 80pp. 8.5"x11". Spiral Paper \$29.95

For papercrafters & others wanting to start making books, this manual gives clear, precise instructions with step-by-step illustrations for 16 projects including meander books, lotus books, tea bag books, flutter books, & single signature. Bestseller.

V26. Simply Bound: A Basic Bookbinding Video by Cheryl Mootte. 2003. 60 minutes. VHS \$29.95

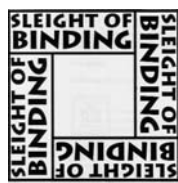

B2480. Sleight of Binding by Cheryl Mootte. 2002. 88pp. 8.5"x11". \$29.95

Cherryl's second how-to manual is about trick books, including flexigons, jacob's ladders, and folded forms. Full of fun stuff! A bestseller at conferences.

S343. Methyl Cellulose. 4oz/\$7.65 8oz/\$10.25 16oz/\$14.00. Used as an adhesive alone or mixed with Wheat Paste or PVA. Increase the drying time of PVA allowing for more repositioning. Makes a wonderful paste for paste papers.

Round Glue Brushes

Unfinished wood handles, pure blond hog bristles with rust free ferrules. For PVA and wheat paste.

S344-8. 5/8" dia. \$7.85

S344-10. 3/4" dia. \$9.25

S344-12. 7/8" dia. \$11.00



S344-8

S344-10

KEITH SMITH

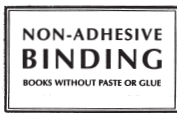

B1537. Non-Adhesive Binding: Books without Paste or Glue by Keith A. Smith. 2nd ed. 352pp. 6"x9". Paper **\$30.00**

B1890. 1, 2 & 3-Section Sewings: Vol. II **\$30.00**
B1891. Exposed Spine Bindings: Vol. III **\$30.00**

B2280. Bookbinding for Book Artists by Keith Smith. 1998. 432pp. 6"x9". Paper **\$35.00**
Presents a simple approach to binding a book in cloth or leather.



B2531. Quick Leather Bindings: Non-Adhesive Binding Vol V by Keith Smith. 2003. 320 pp. 6"x9". Paper **\$30.00**

All the bindings in this volume are hard cover quarter leather. Detailed instructions make leather binding a viable option for a beginner. Steps and instruction

were simplified. No equipment is used, tools are limited, and all use of glue and paste is eliminated. This saves time, eliminating weights and waits.



B2428 Smith's Sewing Single Sheets. Non-Adhesive Binding Vol IV by Keith Smith. 2001. 336 pp. 6"x9". Paper **\$30.00**

The fourth in a series of instructional books on binding without glue or paste, this one presents bindings of single sheets – paper, board, plexi – that open flat to any page. Includes several variations of Coptic sewings, raised cord sewings, and sewing on tapes.



B2563. Structure of the Visual Book: Expanded 4th Edition by Keith Smith. 2003. 420pp. 6"x9". Paper **\$35.00**

An instructive guide to the concepts of visual books, it presents strategies for organizing pictures in the book format. A wide range of bookworks is presented with 129 drawings and 453 photos of books by 145 contemporary book artists from around the world. Almost twice the number of pages of the previous edition.

B2705. Text in the Book Format. Expanded 3rd edition. 2004. 256pp. 6"x9". Paper **\$25.00**

Examines the display of text, on a single page and then as part of a multi-page format. As a part of the physical object and as book pages are turned.

BOOK DESIGN

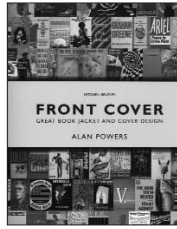

B2906. Front Cover: Great Book Jackets and Cover Design by Alan Powers. 2006. 144pp. 9"x11". Paper \$19.95.

JNB Price \$17.95

New Presents 300 influential book jackets and book covers of the 20th century – all in full color. Discusses the art and typography, how cover art styles helped launch publishing “brands” such as Penguin and Bloomsbury and explores the impact of today’s digitally designed covers.

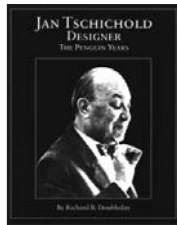

B2903. Jan Tschichold, Designer: The Penguin Years. 2006. 240pp. 8"x10". Hard **\$39.95**

New Focuses on Tschichold's typographic revolution that he applied to Penguin's mass production of books. Includes over 100 color and b&w images of the Penguin Book Series of Tschichold's during the 1940's. Shows many of Tschichold's preliminary hand drawn cover and title page designs which show his meticulous attention to detail. Explains, with many illustrations, the influences that drove Tschichold and his New Typography.

Available January 2007.

Visit johnnealbooks.com for more info:

B2714. Classic Book Jackets by George Salter. Paper **\$35.00**

B2819. Letters of Credit by Walter Tracey. Paper **\$19.95.**

S390. Bookwizard. A multi-function template designed for paper artists and bookmakers. Streamlines measuring tasks, creates perfect squares with diagonals and center points, outline stab binding holes, insure perfect center-align binding holes. Instruction booklet. Sturdy plastic printed with a background grid of 1/8" and measuring guides. **\$16.95**



Misc. Supplies

S538. Smaller Microspatula . \$3.50

S345. Microspatula #1. Stainless Steel. 8" long. \$4.15

New Tweezers. See website for pictures.

S530. Bent wide tip. 4.5" \$2.00

S531. Straight pointed tip. 5" \$2.00

S532. Bent pointed tip. 4.75" \$2.00

S533. Press to open pointed tip. 6.5" \$2.50

S534. Press to open bent pointed tip. 6.5" \$2.50

New Hemostats. Useful in multi-thread bindings. See website for pictures.

S535. Bent tip. 5". \$3.50

S536. Straight tip. 5". \$3.50

S568. Weights. Set of six flat, 2.25" dia. weights. Plastic covered. **\$13.99**

More Bookbinding supplies, page 61-63.

Please see page 36 for ordering information, including shipping charges

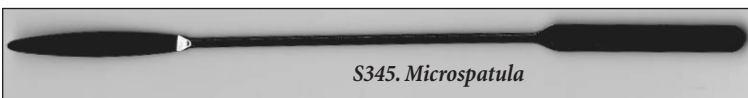

TOLL FREE: 800-369-9598 * WEB: WWW.JOHNNEALBOOKS.COM



BRUSH LETTERING

The best book for brush lettering is **Brush Lettering** by Eliza Schulte & Marilyn Reaves (B1638, \$24.95)



B1638. Brush Lettering by Eliza Schulte (Holliday) & Marilyn Reaves. 2nd ed. 2006. 128pp. 8.5"x11". Paper \$29.95

New This complete how-to guide for both chisel edged and pointed brush lettering demonstrates how to use brushes & how to clean and care for them. Model alphabets are provided. Full of examples of brush lettering from a variety of masterful scribes. One of our bestselling titles. New edition.

B2351-P. Formal Brush Writing by Tom Kemp. 1999. 272pp. 8.5"x11". Paper \$55.00

A thorough instructional book on making Trajan capitals. The first 50 pages cover tools, materials, and practice, discussing – in detail – brushes, how to hold and use them. The

next section covers each of the letters with detailed sequential drawings of the brush making the letter. The final section takes you a step further presenting variations, enlarging and reducing the scale of the Trajan letters, as well as widening and narrowing the letters.

The Origin of the Serif by Edward Catich. 1968 (1991). 312pp. 8"x10.5". **B1540-P.** Paperback \$29.95 **B1540-H.** Hardcover \$49.95

The definitive work on the origin and development of the Roman inscriptional alphabet. Catich convincingly shows that the Trajan capitals were first brush written. Includes Catich's large brush capitals A-Z and instructions on making them. Full of illustrations. A superb reprint for all interested in Roman caps.

Chisel Edged Lettering Brushes

The standard brush recommended by John Stevens and other instructors for chisel-edged alphabets is **BR01. 995 Winsor Newton 1/2" Golden Nylon Chisel Brush.** JNB Price \$16.40

John demonstrated how to use these round ferrule, chisel edge Rekab brushes for smaller roman lettering as well as for a variety of other styles. John uses these along with flat ferrule chisel edged brushes for his brush lettering. These quality sable brushes, imported from Israel, with proper care will last for 20 years or more. These are called "Showcard" or "One Stroke Brushes." They are more versatile than flat ferrule, chisel edge brushes, but take a bit more skill to use. John recommends the #5 to start with. For a wider range of sizes, he suggests adding the #3 & #7.

BR12 Rekab Brushes. Specify size.

Rekab #3 \$11.70. JNB \$10.95

Rekab #4 \$13.30. JNB \$12.50

Rekab #5 \$17.20. JNB \$15.95

Rekab #6 \$24.20. JNB \$21.95

Rekab #7 \$34.80. JNB \$31.95

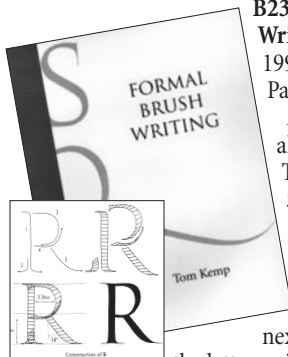

EDWARD JOHNSTON

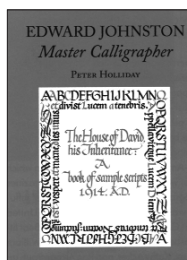

B2912. Edward Johnston: Master Calligrapher by Peter Holliday. 2006. 416pp. 8.5x11. Hardcover \$49.95

New

Edward Johnston was key to the revival of calligraphy in the 20th century.

His *Writing & Illuminating & Lettering* published originally in 1906 is still an important instructional manual. This new volume looks afresh at Johnston's work and legacy, his friendships and philosophy, the people he worked with, and the influence on them and others, and the details of the establishment of the craft community in Ditchling. Peter Holliday was a master scribe.

Pointed Brushes for Lettering & Illumination

Escoda Brushes. Eliza Schulte Holliday, co-author of *Brush Lettering*, highly recommends these brushes from Spain for pointed brush lettering. They have plenty of bounce and good snap and are reasonably priced. Eliza starts her students with the #2 Round pointed sable watercolor brushes.

Eliza's Escoda Brushes

BR19.0 \$7.95 **BR20.1** \$8.50 **BR21.2** \$10.75 **BR22.4** \$15.50

SABLE ROUND POINTED BRUSHES

Sheila Waters recommends these watercolor brushes as a less expensive alternative to Winsor & Newton Series 7. Georgia Deaver tested the brush for us and found it good for brush lettering. For illuminated initial letters you need the smallest sizes. For brush lettering the larger sizes would be more useful. **Cirrus Kolinsky Sable Watercolor Brushes. 110 Rounds**

BR05.00 \$6.35 **BR07.2** \$8.50
BR04.0 \$6.70 **BR08.3** \$10.10
BR06.1 \$7.25 **BR09.4** \$13.10

Cirrus

Brushes shown actual size.

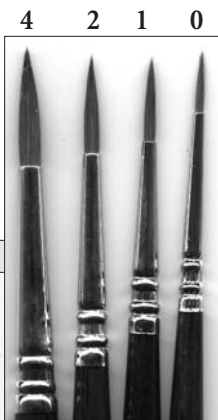
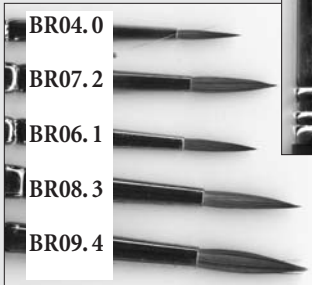

Escoda

CALLIGRAPHY, CALLIGRAPHERS

Lettering & Type Design



Artist & Alphabet: 20th Century Calligraphy & Letter Arts in America. Curated by Jerry Kelly & Alice Koeth. 1999. 136pp. 8"x11".

B2333-P. Paper \$30.00. **JNB \$19.95**

Records this landmark exhibition celebrating the 25th anniversary of the Society of Scribes, Ltd. It assembles 100 calligraphers and lettering artists – from Arnold Bank, John Howard Benson, WA Dwiggin to Al Zanetti and Hermann Zapf – who have shaped the taste and history of the craft in America in the 20th century. 72 pages in color. Limited supply of sale price copies.



B2791. Blackletter: Type & National Identity. 1998.

72pp. 8.5"x11". Paper **\$19.95**

New A series of essays on blackletter type from the 1400's, with a concentration on the 20th century. Relates the type to the culture, graphic design and politics. Many illustrations.

Includes a checklist of German Blackletter types and a brief glossary.

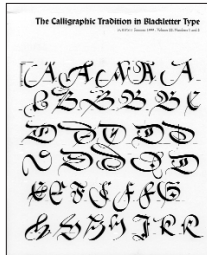

B2785. Calligraphic Tradition in Blackletter Type by Paul Shaw. 1999.

48pp. 8.5"x10". Paper **\$18.00**

New Main focus is German 20th century blackletter types including those by Rudolf Koch, ER Weiss, Ernst Schneider, Imre Reiner,

Georg Trumpp, Paul Renner, Herbert Post, Hermann Zapf, Walter Tiemann, FH Ernst, Fridrich Poppl and others. There is a chapter on Dutch and American Designs as well. Full of examples; many are full alphabets.

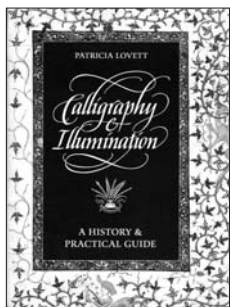

NOW ON SALE!

B2406. Calligraphy & Illumination by Patricia Lovett. 2000. 320pp.

8.75"x10.5". Hardcover \$39.95. **JNB Price \$29.95 through 12-31-06**

Well known calligrapher and expert on the medieval book arts, Patricia Lovett looks at the history of calligraphy and illumination, and explores the use of gold in miniatures and highlighting. Shows how everyone from beginners to experienced calligraphers and graphic designers can create a variety of projects, including how to design and paint a coat of arms. Detailed reference section offers information on

selecting papers and brushes, mixing colors, and preparing and stretching vellum. Also features chapters by Hermann Zapf, Michelle P. Brown, Rosemary Sassoon, and Hubert Chesshyre.



B2809. Calligraphy and Printed Works of Hans Joachim Burgert (Das kalligraphische Werk und die Pressendrucke von Hans Joachim Burgert). 1991. 95pp. 8.25"x11". Paper **\$30.00**

New A fully illustrated catalog of Burgert's work from 1953 to 1990.

Includes calligraphy, limited edition books, unique books, drawings and watercolors. Burgert produced a series of limited edition illustrated books at his Handpresse using both his own fonts, and commercial fonts as well as his calligraphic texts. Includes five-page essay on Burgert's work by Ewan Clayton in English. Rest of text in German – but it is very much a picture book.



B2802. Dutch Type by Jan Middendorp. 320pp. 8.75"x11". Hardcover **\$96.00**

New A comprehensive overview of old and new type design in the Netherlands. Presents the work of the punchcutters, type designers and lettering artists

from the 15th-20th century. Provides insight into the motives and methods of the current type design community, presenting published and unpublished typefaces as well as sketches, studies & samples of unfamiliar lettering work.



B2462. Experiments with Letterform and Calligraphy (Schrift und Kalligraphie im Experiment) by Andre Gurtler. 1997. 252 pp. 9-1/8"x9-3/8". Hardcover **\$86.00**

This book is concerned with the art of calligraphy as one of the bases for the understanding of letter-

form, with particular reference to calligraphic experiment. It will show you how experimentation with letterforms allows a calligrapher to find a new dimension of creativity. Text in both German and English, black and white illustrations throughout.



B2862. Freight Train Graffiti by Roger Gastman, Darin Rowland, Ian Sattler. 2006. 352pp. 8"x7.5" Paper **\$29.95**

New Presents over 1,000 color photos of this mostly letterform graffiti. Eliza Schulte Holliday recommended this

book for her Neuland students to show how forms can be packed tightly.



B2895. Handwritten: Expressive Lettering in the Digital Age by Steven Heller, Mirko Ilic. 2006. 9.75"x10" Paper **\$34.95**

New Covers the wide use of hand drawn forms in posters & other printed materials. Some of the work is elegant; other is raw & unschooled.

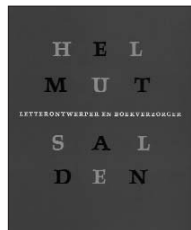

B2767. Helmut Salden. 2003. 9"x11.5". 192pp. Hardcover **\$55.00**

New This beautifully produced book presents the work of Helmut Salden, a 20th century Dutch lettering artist and book designer. It includes book covers & dust

jackets many with hand lettering (1933-1976), book typography, and monograms. Full-color throughout. Cloth binding with dust jacket, ribbon marker. Text in Dutch, but it's a visual feast.

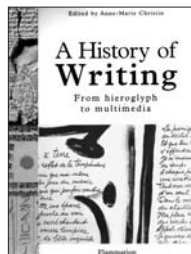

B2505. A History of Writing: From Ideogram to Multimedia. Edited by Ann-Marie Christin. 2002. 408pp. 9-1/2"x11". **\$75.00. JNB \$69.95**

Discusses the oldest, non-alphabet methods of writing, history & spread of alphabets, how the Western alphabet has reincorporated imagery into

writing, & the effects of computer technology. 400 color & b/w illustrations.

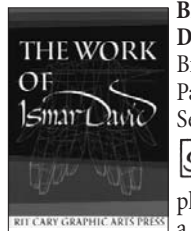

B2766. The Work of Ismar David. Selected by Helen Brandshaft. Edited by David Pankow. 2006. 160p. 8"x11". Sewn paperback. **\$29.95**

Ismar David was one of the great calligraphers of the 20th century. He was a master of historic hands, yet

had his own style – both Latin and Hebrew Alphabets. Presents calligraphy, type design and his other design work.

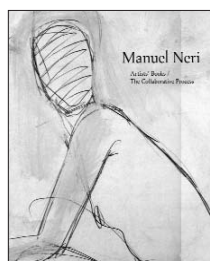

B2785-P. Manuel Neri: Artists' Books / The Collaborative Process by Bruce Nixon. 2005. 194pp. 10"x12". Paper **\$40.00** Signed by *Thomas Ingmire*

New This catalog presents seven artists books. The first four are collaborations: artist, printer,

photographer, binder and are produced in limited editions. Of most the interest to calligraphers are the last three books – each a single copy original. These books present poems by Pablo Neruda (Ode to A Beautiful Nude, Morning, Afternoon & Tonight and Truth and Poetry). Thomas Ingmire has written out each poem in italic – both in English and in Spanish. It's a beautiful volume, though calligraphic text could be sharper.

See page 6 for **B900. Words of Risk: The Art of Thomas Ingmire.** \$16.99 & page 25 for **B2614. Codici 1.** \$22.95 edited by *Thomas Ingmire*.

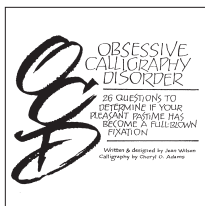

B2872. Obsessive Calligraphy Disorder by Jean Formo. 44pp. 5-1/2"x5-1/2". **\$12.00 2+ \$10.00ea.**

New A delightful amusement for the letter obsessed. Cheryl O Adams has provided an informal decorative initial, a pen sketched little illustration and the question in one of several calligraphic hands. The book ends with a 10 step program. You will get a chuckle!

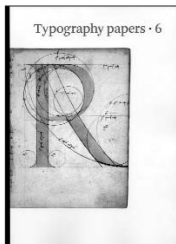

B2890. Typography Papers Number 6: The Classical Tradition in Letters by Nicolete Gray, Giovanni Mardersteig & James Mosley. 2006 128pp. 8.5"x11.75" Paper **\$40.00**

New Four illustrated essays on the reconstruction/reinvention of the classical letter in Italy in the

15th and 16th centuries. Includes Nicolete Gray on the Newberry (Library) alphabet & the revival of the Roman capital; Giovanni Mardersteig's on the revival of the inscriptional letters; Paul Stiff on the design of public letters in Florence, and James Mosley on Cresci and the Baroque letter in Rome. Also, Victor Gaultney's on how the Latin alphabet has been extended to cater to languages without scripts. This issues concerns letterforms, not type or typography in the usual sense.

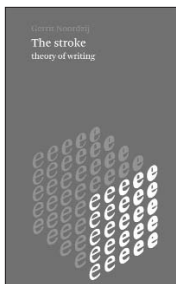

B2893. The Stroke: Theory of Writing by Gerrit Noordzij. 2005. 96pp. 5"x8.5". Paper **\$25.00**

New Presents a theory of writing behind form of letters on the page, whether by pen, pencil, or brush. Concerned not with beautiful forms but with the phenomenon of letters and how they are made in writing. Starting from

basic principles, Noordzij begins with the white space that creates definition by surrounding letters. Then, using simple geometrical concepts, he describes in detail how the strokes of writing can be formed. His theory serves to repair the split between written and typographic letters.

See www.johnnealbooks.com for

B2894. Letterletter Noordzij. Paper **\$24.95**

Visit johnnealbooks.com for these and more books:

B2474. Animalphabet. Gatti. 2001. 6"x7.5" Paper **\$15.00**

CD08. The Calligraphic Art of Denis Brown: \$40.00

B1666. Calligraphic Bookplates & Monograms by Villu Toots. 1992. 7.25"x9.75". Paper **\$29.95**

B2246. Celebrating American Poetry. \$14.95. **JNB \$9.99**

B2714. Classic Book Jackets. George Salter. **\$35.00**

B1647. The Creative Stroke. Emery. \$39.95. **JNB \$19.99**

B322-P. Lessons in Formal Writing by Edward Johnston. 243pp. Paper \$19.95. **JNB Price \$17.95**

B1851. Pointed Pen Variations. Kecseg. **\$19.50**

B2615. Presence & Absence. Paper **\$17.50**

B1228. Workshop Impression by Gottfried Pott. 1989.

Approx. 60pp. 5"x7.5". Paper **\$14.95**

B2330. Writing Beyond Words Exhibit Catalog. 1999.

90pp. 8.5"x11". Paper **\$19.99**

CALLIGRAPHY INSTRUCTIONAL MANUALS

Includes how-to books, as well as source books for alphabets. For instruction and alphabet books for Copperplate, Spencerian, Hebrew, and Brush Lettering, see those separate sections.

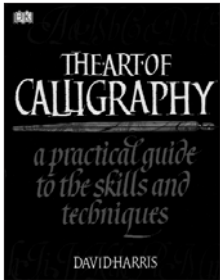

B2013. The Art of Calligraphy: A Practical Guide to the Skills and Techniques by David Harris. 1995. 128pp. 8.75"x11.25". Paper **\$17.95**

This instructional manual presents 24 or so historical hands from rustic to italic. For each hand one or more historical examples are shown. Sometimes an enlarged detail or a modern work in the hand are also given. Harris also gives us some background info on each hand. The instructional material includes exemplar alphabets and a ductus printed in several colors of transparent ink that show the individual strokes and their sequence. Hints on letter formation are given. All illustrations are in full color.

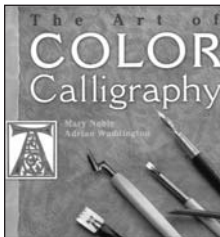

B2538. The Art of Color Calligraphy: A Complete Sourcebook of Color Calligraphy Techniques by Mary Noble and Adrian Waddington. 2003. 176 pp. 8.75" x 8.75". Paper. **\$17.95. JNB Price \$15.95**

This book is not about the form of letters, but how to use various techniques to make them colorful. Step-by-step instructions for creating washes, stippling, sponging, gilding, and more. Here are the hints and techniques you would gather from workshops and classes over a number of years – all collected in one book and illustrated in full color. Also discusses color balance and harmony between lettering, background, and borders.

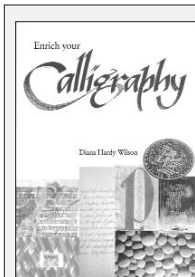

B2225. Enrich Your Calligraphy by Diana Hardy Wilson 1996. 175pp. 7.75"x11.25". Hardcover. **\$29.99. JNB Price \$19.99**

[safe] This is not a book about letterforms but about how to go about creating calligraphic pieces. Further, unlike many recent calligraphy books, this book is generous with the text rather than being a printed slide show with captions. Wilson explains how to be a maker of calligraphic work with both practical and philosophical discussions about design, creativity and the actual production.

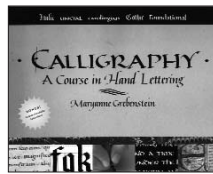

B2888. Calligraphy: A Course in Hand Lettering by Maryanne Grebenstein. 2006. 112pp. 11.25"x9.25" Hardcover spiral **\$19.95. JNB Price \$18.95**



This beginners manual provides instruction for Italic, Uncial (& half uncial, Carolingian, Gothic and Foundational. While mostly black & white, there are a few color photos of historic examples. Translucent plastic guidelines included in the back for each hand.

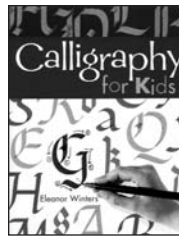

B2629. Calligraphy for Kids by Eleanor Winters. 2004. 128pp. 8.5"x11". Hardcover **\$14.95. JNB Price \$11.99**

A kid-friendly guide. The tools, techniques, & projects have been chosen specifically with children in mind. Alphabets are introduced with mono-line tools. Chisel-edged markers are used instead of dip pens. Includes guidelines (which can be photocopied).

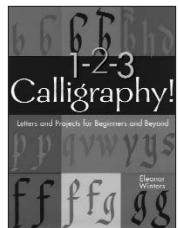

B2832. 1-2-3 Calligraphy: Letters and Projects for Beginners and Beyond by Eleanor Winters. 2006. 128pp. 8.75"x9.25". Hardcover **\$14.95**

[New] While there is duplication from her first book for kids, this is Calligraphy for Kids II. First there is a thorough review of Italic. Then instead of Uncial and Foundational, this one presents gothic variations including Gothicized italic. A series of projects follows. While this one works by itself, Calligraphy for Kids is a better book for beginners. It presents Italic, Foundational, Uncial & basic Blackletter.



B2614. Codici 1. Edited by Thomas Ingmire. 2003. 64pp. Paper. **\$22.95**

Ingmire is best known for his expressive – and often non-legible – calligraphic works. This illustrated notebook draws primarily from Ingmire's teaching. It presents the assignments, support materials, the works created by the students, as well as images and brief discussions of his own recent works that relate to the program. Topics include inventing new forms, lettering as drawing, the expressive line, the shape and space of writing, the word as image, Hans-Joachim Burgert: the calligraphic line, the space of writing: the ditching project. The emphasis is on a visual rather than a verbal message.

Letter Arts Review is a valuable resource for calligraphers & lettering artists of all levels, from beginners to accomplished. The incredible variety and quality of work which fills every issue will enlighten, inspire, amaze, instruct, & delight. Whether it's traditional historical manuscripts, or cutting edge experimental work, Letter Arts Review strives to bring the best calligraphic and lettering art to you. See page 58 to subscribe.



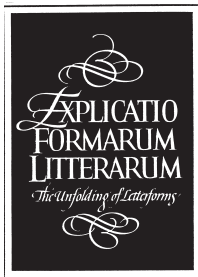

B1277. Explicatio Formarum Litterarum: The Unfolding of Letterforms by Rutherford Aris. 1990. 50pp. plus 23 foldout plates. 9.5"x12.25". Paper over boards \$35.00. **Sale \$29.95**

sale This book displays as graphically as possible the development of the forms of the Latin letters

from the first to the fifteenth century. The foldout plates contain nearly 200 black & white reproductions of various scripts. The text relates the development of letters to that of other arts, making comparisons that shed light on the spirit of an entire age; for example, between the evolution of gothic letters and the pointed arches in gothic cathedrals. Many other fascinating insights into medieval thought, culture & history are included in the book.

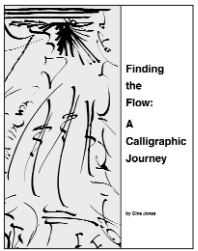

B2830. Finding the Flow: A Calligraphic Journey by Gina Jonas. 2006. 85pp. 8.5 x 11. Spiral bound. Paper **\$19.95**

New A new approach to calligraphy for all levels, which acquaints the scribe with the essential but largely unexplored dynamics of stroke technique. Through

stroke exercises with pencil and edged pen you explore vital movement and sensitive touch. You discover how shoulder, arm, fingers and pen combine with alternating of pressure. The exercises lead to an intimate understanding of the edged pen: a foundation for formal alphabet study, creative alphabet design and artistic self-expression! Begin your calligraphy practice, before starting formal alphabet study, by warming up, sensitizing, and integrating mind and body. Full of illustrations and diagrams.

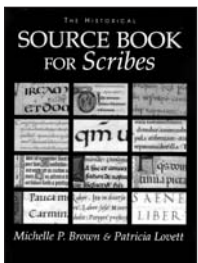

B2317. The Historical Source Book for Scribes by Michelle P. Brown and Patricia Lovett. 1999. 128pp. 8.75"x11.5". Hardcover \$32.50 **JNB Price \$22.50**

sale 14 historical manuscripts, supported by other manuscript examples, are used to explore 15

writing styles. Brown analyzes the production of the manuscripts, setting them in historical context and relating them to those who produced them. Lovett uses the manuscripts to analyze the letterforms in detail and then gives guidance on how to make the letters. Each section includes an interpretation of the historic hand. Each manuscript is reproduced in color. 35 color illustrations.

WANT TO VISIT US?

While we are a mail order operation, you can shop in person. **Please contact us for directions and other info.** We are not usually open on weekends, but may be able to accommodate you if your plans do not permit a weekday visit.

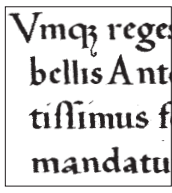

B1747. Humanistic Script: of the 15th & 16th Centuries by A.J. Fairbank and R.W. Hunt. 1993. 40pp. 8"x10". Paper \$11.95. **JNB Price \$5.99**

sale Much of modern calligraphy and typography is derived from these 15th century scripts or hands. A nice addition to your reference library at a sale price.

B020. Insights into Left-handed Calligraphy by Betsy Rivers-Kennedy. 1984. 32pp. 5.5"x8.5". Paper **\$9.95.** For left-handers and teachers. Covers four methods of writing: The Right-Handed Influence, The Sideways Approach, The Hook, & The Upside-down Method. The best book available.

B028. Layout and Design for Calligraphers by Alan Furber. 1984. 64pp. 8.5"x11". Paper **\$9.95**



B025. Italic Letters: Calligraphy & Handwriting by Inga Dubay & Barbara Getty. 1984. (1992) 128pp. 8.5"x11". Paper **\$23.95**

Takes the scribe through a basic, a formal, a chancery & finally a cursive italic handwriting. Each is introduced in monoline, followed then by chisel edged forms. Final chapter on layout and design. In this workbook, the sentences-to-copy form an outline history of written communications from cave paintings to 19th century copperplate. Numerous historical illustrations. Western American style of italic. A popular class text. Recommended.

DVD29. Italic with a Flourish by Margaret Daubney. DVD 52 minutes. **\$32.50**

Using clear demonstrations, explains the features of a formal italic hand, guides you through the letterforms and shows you how to develop and use your skills. Includes plenty of technical advice. Daubney is a tutor at Roehampton.



B2460. Lettering on Glass by Charmain Mocatta. 2001. 112pp. 6"x9". Paper \$24.95. **JNB Price \$14.95**

This book shows you the correct ways to engrave letterforms onto glass, from drill engraving to sand blasting. This is a practical handbook which uses the work of well-known calligraphers who engrave glass to illustrate the text.

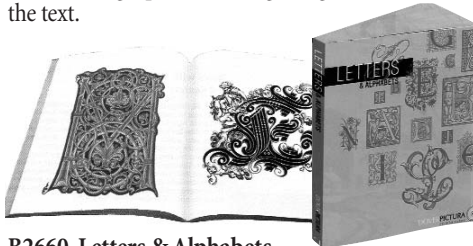

B2660. Letters & Alphabets. 2004. 128pp. Paperback & CD Rom \$39.95 **JNB Price \$36.95**

A varied collection from dozens of sources. Includes 700 full-color and b&w embellished and elaborate letterforms.

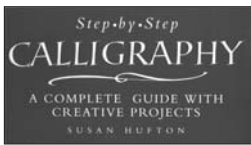

B2029-PB. Step-by-Step Calligraphy: A Complete Guide with Creative Projects by Susan Hufton. 1995. 144pp. 10.75"x10.75".

Paper \$17.95. **JNB \$16.95**

A wonderful book filled with full color photography, full color reproductions, and fine exemplars. Covers letterforms: skeleton letters (roman caps and lowercase), Roman capitals, foundational, italic, flourished italic, uncial, versals, built up capitals. A manuscript reproduction is provided for each alphabet. Next, layout, margins, letter weight and interlinear spacing are presented. Then step-by-step instructions for a series of projects. Recommended by Sheila Waters, Ann Hechle, Annie Cicale, John Stevens and John Neal, Bookseller.

B1795. Teach Calligraphy? Who? Me?: An Introduction to the Gentle Art of Calligraphy Instruction by Betty J. Locke. 1993. 46pp. 8.5"x11". Paper **\$19.95**

For those beginning to teach calligraphy this book provides lots of practical information on kinds of classes, student needs and teaching strategies. It doesn't give you lesson plans, but lets you know how to prepare them. It's like having an experienced teacher to answer questions, give hints, etc.



Sheila Waters, **B2302. Uncommon Numbers Manual**

B2302. The Uncommon Numbers Manual by Brenda Casey 1999. 80pp. 8.5"x5.5". Paper **\$14.95**

Covers the construction of numbers for Uncial (Waters), Blackletter (Dunham), Italic (Alice), Copperplate (Artigas), Bookhand (Cheryl O Adams), Neuland (Rohrs), and Pointed Pen Uncial (Kecseg). For each an exemplar for the alphabet. A ductus and further instruction on the numbers is included with each hand.

B2081. Uncommon Numbers: A Source Book for Artists edited by Brenda Casey and Barbara Brandt. 1996. 64pp. 8.5"x5.5". Paperback **\$14.95**

This source book on numerals has exemplar pages, compositions, commercial pieces using numbers, and typefaces that could inspire calligraphic numerals. Provides much inspiration and source material to help you.



"Versatile Versals."

B1996. Usborne Complete Book of Calligraphy. 80pp. 7"x8". Paper **\$9.95**

A manual for younger scribes, but the letterforms are far superior to many guides for adults! Exemplar alphabets for italic, blackletter, uncial,

versals, foundational. Many project ideas. Recommended for everyone's library, teachers especially. Also includes series of projects.

Written Letters

B040. Written Letters: 33 Alphabets for Calligraphers by Jaki Svaren. 1986. 75pp. 10"x11". Paper **\$19.95**

Covers 33 alphabets with exemplars, ductus, and letter by letter hints on shape and construction. All presented in a beautiful format in red and black. One of our most popular books. Highly recommended.

Visit www.johnnealbooks.com for more info:

B2627. Calligraphy Easel-Does-It. Ouchida-Howells. Paper **\$16.95**

B2449. Calligraphy in 10 Easy Lessons. Winters/Lico. Paper **\$8.95**

B2757. Digital Calligraphy with Photoshop by George Thomson. 2004. 160pp. 8.25"x9.25". Paper **\$24.95**.

B2599. Family Trees. This popular book may be reprinted. You may reserve a copy.

B023. Italic Calligraphy & Handwriting by Lloyd Reynolds. Paper **\$6.95**

B1898. The Pen Calligraphy Manual by Fran (Strom) Sloan. 1998. 112pp. 11"x8.5". Spiral **\$19.99**

V24. A Lesson with David. VHS. 120 min. **\$49.95**

V25. Pen with David. VHS. 85min. **\$34.95**

E10. Pentel Hyperaser. The narrow size makes it ideal for corrections. It is gritty and works for tough corrections, but is surprisingly gentle on paper. A neat, well designed tool. Highly sought after, but almost impossible to find in the USA. **\$10.00 Available in Jan/Feb 2007.**

B2132. Calligraphy by Claude Mediavilla. 1996. 336 pp. 10"x13". Hardcover \$90.00. **JNB Price \$75.00**

safe | An encyclopedic treatment of calligraphy: tools and materials, the history of writing & script, the historical hands (roman caps, rustic, roman cursive, uncial, carolingian, gothic scripts, renaissance writing styles – including 22 model alphabets with ductus), the writing masters, the 20th century calligraphic revival and calligraphy & abstract painting. 490 illustrations, 200 in color.

Full of color illustrations from historical sources and from contemporary scribes. It is also full of Mediavilla's work which is seldom seen in the USA. Worth the price.

Hildegard Koger



WEDDINGS

B1501. Addressing Invitations: Proper Forms of Address by Joan Breman. 4.75"x8.5" folded. **\$3.75**

Only a small folder, but for those new to addressing invitations for weddings and other formal occasions, it provides rules for outside and inside envelopes, addresses for clergy, military, university titles, along with postal suggestions and some additional hints. Can save you time and trouble.



B2475. Wedding Invitations, Announcements, Placecards, and More by Bette Matthews. 2001. 128pp. 8.5"x11". Paper \$22.00. **JNB Price \$19.99**

For the bride or the professional calligrapher, this full-color book provides a wealth of simple to creative

examples of calligraphy (with how-to instruction and helpful hints) for announcements, invitations, placecards, favor tags, envelopes, table numbers and names, menu cards, petal cones, wedding programs, guest books. This is followed by a gallery of wedding calligraphy. 16 calligraphers (of varying skill) have contributed to the volume.

Visit www.johnnealbooks.com for more info:

B2642. Wedding Invitations. 2004. 80pp. 9.25"x 9.25". Paper **\$12.99**

LR19-4. LAR Wedding Issue. 2005. \$17.50 see page 9, 64

MARKER LETTERING

These books by Lynn Slevinsky are all full of fun lettering. All are 8.5"x11" paper spiral bound and have 42-55pp. Purchase all four for \$66.

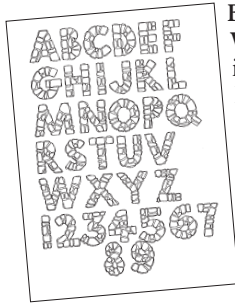

B2559. Marker Lettering

Vol.1. \$18.00. Alphabets include: Fiesta Capitals, Lombardic Capitals, Sticks and Balls, Shadowed Monoline Letters, Balloon Letters, and Rope Letters.

B2560. Marker Lettering

Vol.2. \$18.00. Alphabets include: Wild West, Stencil, (Neon) Lighted, Electric,

Pinked and Stitched, Beaded, Barn Board, Rocks and Pebbles, Peppermint Stick.

B2561. Marker Lettering Vol.3. \$18.00. Alphabets

include: Earth Quake, 60's, Shadows Only, Mardi Gras, Carved in Stone, Through a Window, Letterscapes, So-so Tight, & Curving Caps.

B2562. Marker Lettering Vol.4. \$18.00. Alphabets

include: Gel Pen, MileSTONES, Angles, Chips & Cracks, Squares and Letters, Easy Funky Romans, Dots on a Grid, 3-D Letters Above and Below.

Moving? Send us your change of address. The post office will **NOT** forward our catalog to your new address.

CELTIC

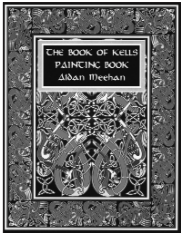

B2897. The Book of Kells Painting Book by Aidan Meehan. 1999. 64pp. 8.5"x11". Paper \$9.95. **JNB Price \$5.99**

sale Drawn from the Book of Kells these 60 full page line illustrations are of animals and people intertwined in knotwork fashion. Use them full sized or reduced as templates for your own illuminations. *Limited supply.*

Also available:

B2728. 101 Celtic Illuminated Letters by Courtney Davis. 2005. 224pp. 6.5"x6". Paper **\$14.99**

CD13. Book of Kells Screen Saver. \$9.95.

B2354. Celtic Calligraphy by Lunnis. **\$16.95**

B2300. Celtic Symbols: 18 Rubber Stamps. Jim Paul. **\$19.95**

DVD31. Book of Kells DVD-ROM. \$33.50 see page 11

B2448. Full-Color Celtic Designs CD Rom & Book by Marty Noble. 2002. 48 pp. 9-1/4"x12-1/4". Paper **\$19.95**

COLOR

B1672. Blue and Yellow Don't Make Green by Michael Wilcox. 2002. 200pp. 8.5"x10.75". Paper \$26.99. **JNB Price \$24.95**

This essential guide presents an easy to follow, step-by-step format for perfecting the art of color mixing. Uses a double primary set, including warm

and cool shades of blue, yellow and red. 480 color illustrations.

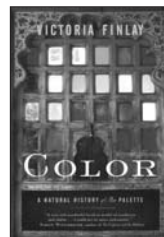

B2624. Color: A Natural History of the Palette by Victoria Finlay. 2003. 464pp. 5x8. Paper \$14.95. **JNB Price \$13.50**

Takes the reader on an adventure around the world and through the ages, illuminating how the colors we choose to value have determined the history of culture itself. Explores the physical materials that color our world, such as precious minerals and insect blood.

From Cyberscribes: "...an amazing book that I can't put down.... It reads like an adventure novel, as she actually visited all the countries, their mines, and their sources."

—Jenny Hunter Groat

B2776. Color by Betty Edwards: A Course in Mastering the Art of Mixing Colors by Betty Edwards. 2004. 224pp. 7x9. Paper \$17.95. **JNB \$16.95**

Using techniques tested & honed in her five-day intensive color workshops, Edwards provides a basic understanding of how to see, use, and mix color & combine hues. Includes 125+ color images & exercises that move from simple to challenging. Edwards helps you see what is there rather than what you "know" in your mind about color.

Visit www.johnnealbooks.com for more info:

B2675. Bright Earth: Art and the Invention of Color by Philip Ball. Paper **\$18.00**

B2514. Color Mixing Swatch Book by Michael Wilcox. 56 pp. 5-1/4"x7-1/2". Paper **\$9.99**



BRINGHURST

B2898. The Tree of Meaning: Thirteen Lectures by Robert Bringhurst. 2006. 320pp. 5.3"x8.5". Paper **\$28.95**

New Lectures on language, focusing on storytelling, mythology, comparative literature, humanity and the breadth of oral culture. Bringhurst's commitment to 'ecological linguistics' emerges in his studies of Native American art and storytelling, his understanding of poetry, and his championing of a more truly universal conception of what constitutes literature. He discusses the process of translation, and the relationship between beings and language. Themes include the nature of language; the nature of meaning; the destruction of the earth as we have known it, occurring side by side with the evident persistence of poetry and meaning.

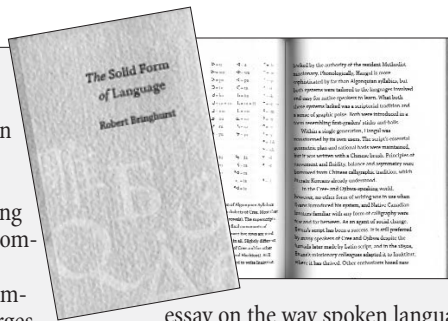

B2695. The Solid Form of Language by Robert Bringhurst. 2004. 80pp. 4.5x7. Paper **\$16.95**

A fascinating essay on the way spoken language has been recorded with visual symbols, beautifully presented in this small volume. Latin and Greek Alphabets, Chinese logographs, Sanskrit and Hindi or Cree and Inuktitut syllabics are discussed as well as parallels with music and mathematics. It's thought provoking and accessible for the lay reader. Smyth-sewn. The book is jacket letterpress printed on St Armand handmade paper.

B1702-P. Elements of Typographic Style. \$29.95
Visit johnnealbooks.com for more details.

DESIGN/LAYOUT/USING TYPE

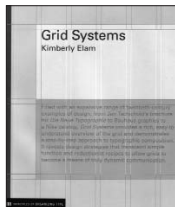

B2892. Grid Systems: Principles of Organizing Type by Kimberly Elam. 2004. 120pp. 7"x8.5". Paper **\$19.95**

New Filled with extensive research and more than 100 informative examples from the Bauhaus to Nike ads, *Grid Systems* provides a rich, easy-to-understand overview and demonstrates a step-by-step approach to typographic composition. It suggests design strategies that transcend simple function and reductionist recipes to allow grids to become a means of truly dynamic communication. Chock-a-block full of colorful examples, helpful vellum overlays, and Elam's insightful analysis.



B2891. How To Be A Graphic Designer Without Losing Your Soul by Adrian Shaughnessy 2005. 160pp. 7.5"x9". Paper **\$19.95**

New Addresses the concerns of young designers who want to earn a living by doing expressive and meaningful work, and who want to avoid becoming hired drones working on soulless projects. Written by a designer for designers, it combines practical advice with philosophical guidance to help professionals embark on their careers.

Any of these three books is a great introduction to using type. *Thinking with Type* is the most general, *Type Rules!* best for specifics on using type through InDesign (& Quark).

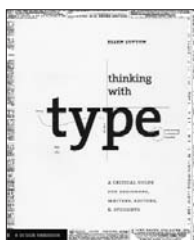

B2876. Thinking with Type: A Critical Guide for Designers, Writers, Editors and Students. 2004. 176pp. 7"x8.5". Paper **\$19.99**

New A first course on using type. First deals with the letters, then putting those letters together

in text, and then putting that text together into grids on a page. It's a sophisticated presentation of the principles of type and typography. Full color throughout.



B2875. Type Rules! The Designer's Guide to Professional Typography by Ilene Strizner. Second Edition. 2006. 224pp. 8.5"x11". Paper **\$45.00**

New A highly recommended practical textbook on using type. The basic and more advanced techniques and principals are presented in a logical and accessible way. Includes exercises and up-to-date instructions on how to put what you learn into practice with Adobe InDesign and Quark. Used by many colleges for the Typography 101 class.

Designing with type

B2913. Designing with Type: The Essential Guide to Typography 5th Edition by James

Craig. 2006. 176pp. 8.75"x11". Paper **\$24.95**

New This 5th edition updates this standard text – first published in 1971 – to the 21st century. Chapters include: basics of typography, 5 classic typefaces, designing with text and display type, color, projects, and type specimens. Has an online resource that complements the book.

Visit johnnealbooks.com for more details:

B2665. American Type Design and Designers by David Consuegra. 2004. 320pp. 8.75x11.25. Paper \$35. **JNB \$31.50**

B2818. Anatomy of a Typeface by Alexander Lawson. 2002. 320pp. Paper \$24.95. **JNB Price \$19.95**

B2817. Essay on Typography by Eric Gill. 1988. 188pp. Paper **\$10.95**

B2819. Letters of Credit by Walter Tracey. 2003. 224pp. Paper **\$19.95**

See page 14 for more design books.

HEBREW

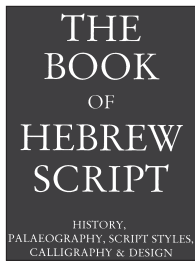

B2255. The Book of Hebrew Script: History, Paleography, Script Styles, Calligraphy and Design by Ada Yardeni. 1997. 364pp. Hardcover \$69.95 **JNB Price \$67.50**

A comprehensive work by a noted paleographer, graphic artist and type designer.

Covers history of the alphabet and the birth of the Hebrew script, Hebrew script in early manuscripts, printed Hebrew script, and Hebrew paleography. A series of alphabet charts follow on the various hands. The final section is on Hebrew calligraphy with techniques and exemplar alphabets. Originally published in Hebrew. Now available in English. 290 illustrations.

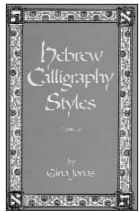

B1619. Hebrew Calligraphy Styles by Gina Jonas. 1996. Second edition. 24pp. 5.25"x 8.25". Paper **\$16.00**

Jonas has revised & reprinted her instructional manual adding three contemporary styles & reworking some of the original ones to make them closer to historical models.

Covers Sephardi, Ashkenazi, Ancient, & Mizrahi. Exemplar, ductus & notes on construction given for each style.



B2416. Ketubah: The Art of the Jewish Marriage Contract by Shalom Sabar. 2001. 200pp. 9.5"x13.25". Hardcover \$50.00. **JNB Sale \$24.95**

Illuminated ketubah, the traditional Jewish marriage contract, have been produced over the last

400 years. This volume presents a broad selection from Jewish communities from the Near East to Northern Europe. The primary focus is Italy where during the 1600-1700's ketubah were beautifully produced under the influence of Renaissance and Baroque art. Discusses Jewish marriage customs.

For **Carved Memories:** Heritage in Stone from the Russian Jewish Pale see page 32.

See johnnealbooks.com for more info:

B2821. Ketubbot: Marriage Contracts from the Jewish Museum. Introduction by Claudia Hahson. 7.5"x8.25". Hardcover \$19.95. **JNB Sale \$9.99**

ILLUMINATION

B2873. 1001 Illuminated Initial Letters by Owen Jones. 32pp. 9.25"x12.25". Paper **\$9.95**

New Michael Sull uses this resource for illuminated initials for recognition scrolls and other pieces. Many examples of each letter with the examples presented in a range of sizes.

Returns: If you don't want an item that you have received, return it for exchange, credit, or refund. Used items cannot be returned unless defective. See page 36 for details. You may not need to return defective/damaged items. Please call before returning.



B004. The Calligrapher's Handbook. Edited by Heather Child. 1985. 260pp. 7.25" x9.75". Paper **\$20.00**

A detailed manual of traditional craft technique including Sam Sommerville on Parchment and Vellum. Dorothy Hutton on Pigments & Media and on

Illumination & Decoration, and Donald Jackson on Gilding and quill cutting. Essential reading for the modern illuminator, especially for laying gold. *These copies are all shelfworn. Covers are scuffed, but inside is fine. Out-of-print in the USA.*

B1999. Illuminated Initials in Full Color by Carol Grafton. 1995. 48pp. 9.25"x12.25". Paper **\$12.95**

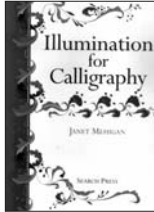

B2455. Illumination for Calligraphy by Janet Mehigan. 96pp. 2001. 8.5"x11.5". Paper \$21.95. **JNB Price \$20.95**

This how-to manual presents designing and layout, gilding, ornamentation and more. Full-color throughout.



B2002. Ready-to-Use Ornate Letters and Initials. 1995. 64pp. 8.25"x11". Paper **\$6.95**

813 different initial letters are printed one side only on glossy paper. This cornucopia of capitals presents letters in a wide variety of styles. All are copyright free.

B1299. Secreta: Three Methods of Laying Gold Leaf by Joyce Grafe. (1985) 1990. 96pp. 9"x6". Paper **\$14.95**

Covers use of (1) gum ammoniac, a simple and rapid method; (2) gesso, for a raised, mirror finish; and (3) Hyplar, a modern gloss medium that is less temperamental than gesso.



CD14. The Technique of Raised Gilding by Jerry Tresser. 2006. 72pp. CD in PDF format. **\$24.95**

New This practical gilding manual provides a scientific and historical analysis of the materials and techniques for raised gilding with gesso and provides

step by step instructions. Tresser approaches gilding as chemist to demystify the craft process and help you to be consistently successful. Provides an in-depth discussion of the preparation and application of the gesso. CD includes color photos, not in the original printed edition. *(You need Adobe Acrobat Reader, a free downloadable program, to view/print the book.)*

WANT TO VISIT US?

While we are a mail order operation, you can shop in person. **Please contact us for directions and other info.** We are not usually open on weekends, but may be able to accommodate you if your plans do not permit a weekday visit.

Mira Calligraphiae

B2547. The Art of the Pen: Calligraphy from the Court of the Emperor Rudolf II by Lee Hendrix and Thea Vignau-Wilberg. 2003. 64pp. 5.25"x7-5/8". Hardcover \$14.95

This new publication excerpts 48 pages from *Mira calligraphiae monumenta*. This renaissance MS displays the virtuosic work of scribe Georg Bocskay. Includes a variety of italic hands, historical, invented and exhibition hands, Rotunda, blackletter. Fruit, flowers, insects, and other natural miniatures painted by Joris Hefnagel fill the spaces on each manuscript page. It's a marvel!

B2179. Nature Illuminated: Flora & Fauna from the Court of Emperor Rudolph II. Hardcover



\$14.95 Similar book from the same manuscript as *The Art of the Pen*.

B2591. Picturing the Natural World Postcard Book. 2003. 4.25"x6". Paper \$12.95

One each of 30 images. 24 feature the amazing calligraphy and the exquisite miniatures of flora and fauna. Six are of the constructed letters. *Limited supply.*

B1645. Mira calligraphiae monumenta: A 16th-Century Calligraphic Manuscript inscribed by Georg Bocskay and Illuminated by Joris Hoefnagel. Edited by Lee Hendrix & Thea Vignau-Wilberg. 1992. 412pp. 5.25"x7.5". Hardcover with cloth covered slipcase.

\$150. JNB Price \$140

This is a manuscript copybook with a vast array of contemporary (1561-62) and historical hands. It is a lettering extravaganza of incredible technical skill. 30 years after its creation it was illuminated by Europe's last great illuminator. Reproduced in complete facsimile accompanied with a commentary.



Source book for *acanthus leaves*

B2786. William Morris Full-Color Patterns and Designs. 48pp. 9.25x12.25. Paper \$10.95

New Michael Sull uses this book in his instructional session on acanthus leaves.

Acanthus leaves are a traditional motif, frequently used in engrossed awards, as well as, other calligraphic broadsides and illumination.

Visit www.johnnealbooks.com for more info:

B2787. The Bible of Illuminated Letters by Margaret Morgan. Spiral Hardcover \$24.99. JNB \$22.50 see page 11

V32. Books & Kings: Discovery of Art. VHS. \$19.95. JNB \$7.99

B2603. Full-Color Illuminated Initials CD-Rom and Book. 2003. 48pp. Paper \$19.95

B2578. The Materials and Techniques of Medieval Painting by Daniel V. Thompson. 239pp. Paper \$9.95

T-Shirts see JohnNealBooks.com

CALLIGRAPHY & TYPE



B2908. Fraktur mon Amour by Judith Schlansky. 2006. 646pp. 5"x8" Hardcover \$75.00

New Presents over 300 Blackletter fonts (capitals, lowercase, numbers, accented characters along with a brief text setting). Covers rotunda, batarde, textura, schwabacher, fraktur,

modern, initials/decoratives, and contemporary fonts. For each font, date, designer and original foundry along with digital foundry/web address where applicable. Facing each font page is a decorative page using characters from the font. Printed in black and pink. CD-Rom with 130 blackletter fonts included.

PROJECTS

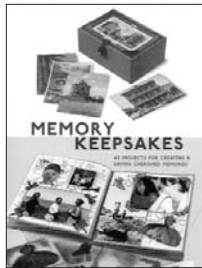

B2730. Memory Keepsakes: 43 Projects for Creating and Saving Cherished Memories by Connie Sheerin, Janet Penseiro, Barbara Mauriello, Kathy Murillo. 2003. 304pp. 8.75"x11". Paper \$19.95
JNB Price \$9.95

It's easy to transform family treasures into wonderful, memory-filled gifts and home accessories. More than 30 projects present ideas for turning children's artwork, grandmothers' buttons, family photographs, and antique linens, etc., into contemporary keepsakes. Teaches collectors and crafters how to build 13 special boxes to store favored mementos, such as cherished postcards, letters, jewelry, photographs, and more. Over 250 photographs and illustrations are included.

EARN A \$10 JNB GIFT CERTIFICATE!

Your local bookstore (independent or chain), art supply store, rubber stamp store, scrapbook store, or paper store can now carry *Letter Arts Review* and *Bound & Lettered*. Provide us with the name and address of a store or stores you think you would be interested in carrying either of these publications and we will send the store a wholesale packet. They can either purchase directly from us or order through our distributor, Ingram Periodicals.

Do encourage local stores to order directly from us. They get a great discount and you receive a \$10 gift certificate if they order 6 copies! National chains will want to order through our distributor, Ingram Periodicals, in which case you will only receive our thanks and heartfelt appreciation for promoting these great publications.



LETTERCUTTING



B2724. Carved Memories: Heritage in Stone from the Russian Jewish Pale by David Gberman. 2000. 167pp. 8"x12". Hardcover \$29.95. **JNB Price \$14.95**

Great black & white photos of grave stones with detail shots of both lettering and decorative carving. Includes both incised and raised letters. Stones date from the 1700's through the late 1800's. All are Hebrew letters, both incised and raised. Introductory essays on Jewish Gravestones and on Jewish Life in Eastern Europe.



B2803. Heavens Above: Incisive Letterwork by Brenda Berman & Annet Stirling. 2005. 72pp. 6.25"x8.5". Paper \$17.95

Presents 14 works with brief text by the artists on the process, preliminary drawings, detail shots and full color photos of the piece.

Presents conventional and unconventional works. Also includes brief essays on letterforms & letter-carving. Over 60 illustrations, most all in full color.



Available again!

B2526. Letter Cutting in Stone by Richard Grasby. Revised ed. 2002. 160pp. 8.25"x11.75". b/w illust. Paper \$45.00

A thorough practical manual on cutting letters in stone. Includes tools, workspace & equipment, cutting exercises and practice strokes, cutting letters in stone, carving raised letters, design, and siting. Highly recommended. Full of illustrations.

B2610. Letters Slate Cut: Workshop Practice and the Shaping of Letters by David Kindersley and Lida Lopes Cardozo. Second Edition. 1990. 7.5"x10". Paper. \$35.00

A practical instructional manual plus a gallery of 57 of David Kindersley and Lida Lopes Cardozo's letter carvings. A "sequel" to the original 1981 edition. Thirty of the pieces in the gallery were not in the earlier edition. Color cover, b&w interior.



B520. Schrift + Symbol in Stein, Holz und Metall By Sepp Jacob, P. Donatus and M. Leicher. 1984 (1995). 328pp. 10"x11". Hardcover \$98.50

Hundreds of b/w illustrations. An exhaustive study of carving in stone, wood and metal, with many

exemplars of historical and modern alphabets. Text in German but full of illustrations that make it valuable for everyone. From Germany. Recommended by Reggie Ezell, Hazel Dolby & others.

Visit johnnealbooks.com for more info:

B2287. Tom Perkins – Lettercarver. Paper. \$22.95

B2389. Letters for the Millenium. Kindersley. \$19.95

PROJECTS



B2612. The Complete Book of Papermaking by Josep Asunción. 2003. 160 pp. 12"x9.5". Hardcover \$24.95. **JNB Price \$22.50**

Richly illustrated and comprehensive. Shows, through beautiful color photos, how to make your own paper, from the preparation of the pulp through the final pressing of the sheets & the drying.

B2508. Paper Quilting: Creative Designs Using Paper & Thread by Bridget Hoff. Paper \$14.95



B2756. Paper, Scissors, Sculpt: Creating Cut-and-Fold Animals by Ben A Gonzales. 2005. 96pp. 8.5x10". Paper \$9.95

These animals – each made from a single sheet of paper – are created in three steps. Score the paper, cut out the design and then

fold. Includes instructions, patterns and examples of finished animals: butterfly, swan, whale, bear, kangaroo, squirrel and many more. For both kids & adults.

For Cheryl Moote's *Paper Delights*, see page 20.

For Colored Pencils, see page 59.

MAKING CARDS



B2640. Designing Handcrafted Cards: Step-by-Step Techniques for Crafting 60 Beautiful Cards by Claire Sun-Ok Choi. 2004. 96pp. 8.5x11". Paper \$20. **JNB \$18.95**

Presents step-by-step instructions for simple card designs for a variety of

occasions. Each card has an understated elegance. The author uses only a few basic card shapes, all starting with a 5"x10" piece of card stock. Unique techniques including paper quilling, decorative cutting, piercing, embossing, layering and weaving are added to the basic card shapes to create truly beautiful designs.

Visit johnnealbooks.com for more info:

B2398. Art of the Scrapbook. Maurer \$24.95

B2594. The Complete Guide to Card Making JNB \$19.99

B2607. Chinese Knots for Beaded Jewellery \$19.95

B2764. Creative Beads from Paper & Fabric \$16.95

B2634. Fast Cards. Beaman. \$19.95. **JNB Price \$15.95**

B2731. Pop-Up and 3-D Cards: Step by Step Projects to Make at Home. Angel. Paper \$9.95

B2635. Quick & Clever Handmade Cards. Hickey. 105pp. 8.5"x11". Paper \$19.99. **JNB Price \$15.99**

Bound & Lettered

NEED SOMETHING NEW TO INSPIRE YOU?

Subscribe to *Bound & Lettered* (formerly *Tabellae Ansatae*) and have each issue – filled with practical information on artists' books, bookbinding, calligraphy, and paper craft – delivered to your mailbox. *Bound & Lettered* features: how-to articles with helpful step-by-step instructions and illustrations, artist galleries featuring the works of accomplished calligraphers & book artists, useful articles on tools & materials, and book & exhibit reviews. You will find each issue filled with wonderful ideas and projects. **Subscribe today!**

Subscriptions

♥ 4 issues (1 year)

USA: \$26 Canada: \$32 USD Others: \$40 USD



CURRENT ISSUE

BL5-4. Articles include Fabric Envelopes, Love Note Bookmark, Renaissance Theater, An Introduction to Colored Pencils, Book Arts Mosaic, The Coptic Connection, Simple Pocket Books Without Sewing or Gluing. **\$8.50**

BACK ISSUES

TAB1.1. Premier Issue. Articles include Tape Bindings by S. Laplantz, Suminagashi by D. Maurer-Mathison, Pulping with Kids, Letters to Myself by Alan Blackman, The Secret Slipcase: Pockets on Every Edge by Pam Sussman and more. **\$8.50**

TAB1.4. Tabloid Format. Articles include Nib Sharpening by Randal Thompson, Stan Knight on Ruling Guidelines and Writing on Vellum, A Dong Paper Folded Box by Gail Rossi, Making Cardboard Prints by Peter Linenthal, Kapa; The Bark Cloth of Hawaii, What Script Is It by Micheal Sull, Four Needle Book by Patricia Grass, and more! **\$5.95**

TAB2.1. Articles include A Little Article about Paste Paper, Slit & Slot Books, The Book as Personal Adornment, Teacup Accordion Fold Card, Origami Rainbow Book, Adhesives for Calligraphy & Book Arts, Creativity on Schedule, and Copyright Laws for Calligraphers and Book Artists. **\$8.50**

TAB2.2. Articles include Pop-in Cards, Gyotaku, Creating Cards, Making Walnut Ink, Romanesque Braid: Single Station Binding. **\$8.50**

TAB2.3. Articles include A City of Stories, Pyramid Miniature Book, Paste Paper Playday, Medieval Turn Ins, Can't Resist Resist, and Profile: Jocelyn Curry. **\$8.50**

TAB3.1. Articles include Making a Sewing Cradle, Learning a Hebrew Alphabet, Rediscovering Decorated Letters, Gallery: Stephen Rapp, Sonnet Fan Book, Ostrich Egg Project, Creating Background Papers. **\$8.50**

BL3.4. Articles include Edible Book Exhibit, Seasons Accordion Book, Uncial: History and Technique, Christmas in July, Experimenting with Art Paste,

Fabric Books, The Art of Antiquing Paper, Letters with Attitude. **\$8.50**

BL4.1. Articles include Paint Pearls, Dragon Book Collaboration, Tabletop Publishing, Artists' Journals in a Day, Mayan Hearts, How to Make a Secret Compartments Mini-Book, An Open Book, Gallery: Alice Simpson. **\$8.50**

BL4.2. Articles include Japanese Bookbinding, Leslie Tardy: Calligrapher, Paper Treasures, Bone Alphabet, Triangle Card, Profile: Richard Minsky, Make a Pop-Up Box, Calligraphy Acrostics. **\$8.50**

BL4.3. Articles include Illuminating the Word: The Saint John's Bible, Victorian Puzzle Purse, Pangramerick, Two Compound Triptyches, Lettering on Glass Spheres, The Great Book of Gaelic. **\$8.50**

BL4.4. Festival of Cards issue! Articles include Making Origami Ornaments, City of Light, Incantations by Maya Women, Pop-Up Templates, Library of Michigan Book Arts Exhibit. **\$8.50**

BL5.1 Articles include Tunnel Vision, Pocket Books, House of Cards, Kards for Katrina, Water Lily Book, Basics of Foundational, Rubber Stamp, Origami Secret Square. **\$8.50**

BL5-2. Articles include Concertina Ornaments, Flag Books, The Manuel Neri/Pablo Neruda Book Project, Wire Bound, Envelope Art: Part One, Friendship Book, The Printmaker's Baren. **\$8.50**

BL5-3. Articles include Gelatin Monoprinting, Freedom to Create with Handmade Paper, Visiting the Book of Kells, Two Calligraphic Hangings, Hugs in Support of Our Military, Happy Birthday Pop-Up Carousel Card, Birthday Boxes, Books About Books. **\$8.50**

Shipping for back-issues-only orders

USA: Add \$2 first issue / \$1 each additional issue

CANADIANS: Add \$3 first issue / \$1 each additional issue

ALL OTHERS: SURFACE: Add \$5 first issue / \$2 each additional issue. AIR: \$8 first issue / \$4 each additional issue.

Issues not listed are sold out. Sample issue (3.2) is available in PDF format at www.JohnNealBooks.com



INDEX

BOOKS

CATEGORIES

BOOKBINDING 2-4, 17-21

Altered Books 2,17

Artists' Journals 19

Barton, Carol 2

DVD's 18

Fine Bindings 7, 19

How to/Reference 6-7

Johnson, Paul 3

Moote, Cherryll 20

Smith, Keith 21

Traditional

Bookbinding 2, 18

BOOK DESIGN 21

Bringhurst, Robert 29

BRUSH LETTERING 22

CALLIGRAPHY & CALLI-

GRAPHERS 5-6, 23-24

DESIGN 14, 29

Botts, Tim 14

Burgert, Han Joachim 23

Cicale, Annie 8

Howell, David 27

Ingmire, Thomas 6, 24

Jackson, Donald 10

Jonas, Gina 26, 30

Pott, Gottfried 8

Stevens, John 16

Waters, Sheila 7

Zapf, Hermann 16

CALLIGRAPHY

INSTRUCTIONAL

MANUALS 6-8, 22, 25-28, 30

Weddings 28

CALENDARS 14

CELTIC 28

Christmas 13

COLOR 28

COLLAGE 12

COPPERPLATE 23

HANDWRITING 12

HEBREW 30

ILLUMINATION 10, 11, 30

Jacobs, Michael 4

Making Cards 32

Maurer, Diane 12

MARKER LETTERING 28

LETTERCUTTING 32

ORIENTAL 59

PAPERCRAFT 4, 12

Paste Papers 12

POP-UPS 13

PROJECTS 32

QUOTATIONS 35

Poetry 16, 23

Sabuda, Robert 13

SPENCERIAN

Sull, Michael

USING TYPE 16, 23, 29, 31

INDEX

Books are arranged alphabetically by title within the sections. Supplies generally follow books.

Afrikan Alphabets 5

Arabic for Designers 5

Art & Craft of Hand

Lettering 8

Art & Craft of Handmade

Cards 29

Art of the Pen 26

Belle Lettère 9

Benedictional of St

Aethelwold 14

Bible of Illuminated Letters 11

Book of Kells CD-ROM 28

Books Unbound 4

Calligraphic Type Design in

the Digital Age 16

Calligraphy/Mediavilla 27

Canticle of the Sun 16

Cards that Pop-up,

Flip & Slide 4

The Character 16

Colored Pencil for Serious

Beginner 57

Complete Book of

Bookbinding 2

Classic Book Jackets 21

Creative Correspondence 4

Creative Stroke 24

Gilding for Calligraphers

DVD 11

Decorated Journal 4

Envelopes 15

Expressive Handmade

Books 4

Graceful Envelope 15

Great Book of Gaelic 5

Historical Scripts 8

Illuminating the Word 10

Lesson with David VHS 27

Literacy through the

Book Arts 3

Making Books that Fly,

Fold... 4

Modern Gilding for

Calligraphers DVD 11

Nature Illuminated 31

Painting with Words: Book,

Poster 10

Pen with David VHS 27

Penland Book of

Handmade Books 3

Picturing the Natural

World 31

Pocket Paper Engineer 2

Pony Express 15

Pop-ups 2, 4, 13

Roundel of the Seasons 7

Solid Form of Language 29

Speedball Textbook 8

St John's Bible 10

Under Milk Wood 7

Virtue & Happiness 27

Wedding Issue (LAR) 9

Woven & Interlocking

Book Structures 3

World of Alphabets

CD-ROM 16

Write Now 12

CD-ROMS 13, 16, 22, 26, 28

DVD/VHS 10, 11, 18, 22-3, 27-8

LETTER ARTS

REVIEW 9, 58

BOUND & LETTERED 33

SUPPLIES

CATEGORIES

BOOKBINDING 20-21, 62-63

BRUSHES 22, 50

COPPERPLATE 45, 46-49

CUTTING TOOLS 59, 61, 63

ERASERS 41

FINE PAPERS 38-39

FOUNTAIN PENS 51-52, 60

GILDING 42, 43

GOLD/SILVER 42, 55

GOUACHE 44, 56

GUIDES/RULERS 43

GUMS 43

MISC. 39, 41

NIBS 40-41, 45-46, 49

HOLDERS 41, 49, 53

INKS 17, 42, 51, 54, 55

MARKERS 43, 50, 55

PADS 39, 47, 48

PASTE PAPERS 12

RULING PENS 60

QUILLS 52

SPENCERIAN 47-48, 49

VELLUM 42, 43

WATERCOLOR 44

INDEX

5-Line Pens 40

Adhesives: Jade PVA, 20

Methyl Cellulose 20

Wheat Paste 20

Agate Burnisher 53

Ampad Embassy Pad 48

Arches Watercolor,

Text Laid, Text Wove, Cover

Papers 38

Arkansas Stone 41

Artist's tape 39

Ames Lettering Guide 43

Automatic Pens 41

Awls 62

Best Bottle Sumi 54

Blackwell Oblique Holder 49

Blotting Paper 48

Boku Undo Marbling Set 56

Book Presses 61

Bookbinding 63

Needles, Thread,

Fabrics: Super, Hinge Cloth,

Stretch Linen & Irish Linen

Bookboard & Book Cloth 63

Bookwizard 21

Bone Clasps 63

Bone Folders 62

Brause Nibs 40, 46, 49

Markers 42

Brushes

Glue 20

Mixing 39

Sable (Cirrus, Escoda) 22

Brush Markers 50

Burnishers-Agate, Hemitite 53

Ball 39

Calcium Sulfate Dihydrate 43

Calendars 14, 16

Canson Pro-Layout

Marker Pad 39

Cards, blank 59

Cat Calendar, Cards 16

Centering Gauge 43

Centering Ruler 43

Century Oblique Holder 49

Chinese Seal Set 60

Cirrus Brushes 22

Clairefontaine Pads 48

Colored Pencils 59

Copperplate 45, 46, 48, 49

Practice Grid Pad 46

Crocus Cloth 41

Cutting Tools 59, 61, 63

Dahle Trimmer 61

Deckle Edge Rulers 43

Del Tysdal Holder 49

Dental Pumice 43

Dinky Dips 49

Diploma Parchment 38

Dropper Bottles 39

Easels 45

Easel Tote 45

Envelope Please 15

Escoda Brushes 22

Erasers 41

Excel 59

Fabriano Ingres 38, 59

Fine Papers 38, 59

Fish Glue 43

Flat Point Pencil Sharpener 41

Folded Pen 60

Fountain Pens 51, 52,

Brush 60

G-tech pen 53

German Ingres 38

Gesso 43

Gilder's Bole 43

Gilders Cushion 43

Gillott Nibs 45

Glassine 38

Glue Brushes 20

Glue Stick 39

Gold

Gold Leaf 42

Gouache 48, 55, 56

Markers 55

Pan Gold 55

Shell Gold 42

Gouache

Graham 44

Holbein 55, 56

Metallic 48, 55-56

Schmincke 56

Winsor Newton 56

Guidelines 43

Guides & Rulers 43

Gum Ammoniac,

Arabic, Sandarac 43

Headbands 63

Hematite Burnisher 53

Higgins Eternal 42

Holders, Straight 41, 49, 52

Oblique 49

Inkwell 15, 52

Inks

Black 42

Color 54-55

Herbin Fountain 51

Iridescent 54

McCaffery's 54

Metallic 54-55

Oak Gall 54

Walnut 54

Seal 60

Sumi 42, 54

White 42, 54

Ink Stick, Stone 44, 60

Ink Sticks

Chinese 60

Japanese 44

Instacoll 43

Iridescent Medium 42

Jade PVA 20

Japanese Push Drill 62

Jars, Plastic, Glass 44

Green 52

Journals, Blank 59

Knives, Bookbinding 62

Kutrimmer 61

Lamy Fountain Pens 51

Light Boxes 53

Linen Tape 63

Linen Thread 63

Linux Ruler 43

Magnifier 41

Manuscript Fountain

Pen 52

Marbling Set Boku Undo 56

Markers

Blender 59

Brush 50

Chisel Edge 50, 55

Metallic 55

Pads 39, 48, 53, 59
 Ampad Embassy Pad 48
 Cross Drill 47
 Fabriano Ingres 59
 JNB Graph Pad 39
 Papier Japon 53
 Practice /Layout 39
 Spencerian Practice 47
 Palettes 39
 Paper, Pads 38-39, 47-48, 59
 Paper, Fine (Sheets) 38, 39
 Papyrus 38
 Parallel Pen 51
 Parchment: See
 Pergamenata (Paper) 38
 Vellum (Skin) 42-43
 Diploma Parchment (Paper) 38
 Paste Paper Scrapers 12
 Pebeo Drawing Gum 39
 Pelikan Ink, 4001 54
 Fount India 42
 Pen Roll-up 41, 49
 Pens
 Automatic 41
 Folded 60
 Ruling 60
 Witch 40
 Pentalic Paper for Pens 39
 Pentel
 Color Brush 50
 Metallic Color Brush 50
 Brush Fountain Pen 60
 Waterbrush 50
 Pencils 41
 Pergamenata 38
 Pilot G-Tech Pen 53
 Pilot Parallel Pen 51
 Pipets 39
 Pliers 47
 Plexi for Easel 45
 Polishing Paper 41
 Principal Nib, EF 49
 Prints/Posters
 Sheila Waters Roundel 7
 Donald Jackson Painting with Words 10
 Pumice 43
 PVA 20
Quills 52
Rotring Fountain Pen 52
 Rulers, Centering, Deckle, Steel 43
 Ruling Pens 60
Sandarac 43
 Scalpel, blades 63
 Schmincke
 Gouache 48, 56
 Metallic Powder 55
 Pan Watercolor 55
 TrolCol Powder 55
 Scoring Tool 62
 Screw Posts 62
 Scroll Nibs 40
 Automatic Pens 41

Sepia Ink (Walnut) 17, 54
 Sheaffer Fountain Pen 52
 Speedball Nibs 40
 Spencerian Supplies 45-49
 Spectralite Ink 55
 Spray Fixatives 39
 Sull Leather Pen Roll-Up 49
 Sumi Ink 42, 54
 Suminagashi Set 56
Tape Nibs 40
 Teflon Folder 62
 Titanium Dioxide 43
 Thomas Hoyer Ruling Pen 60
 TroCol Powder 55
 Tweasers 21
 Twist Drill 62
 Tysdal Oblique Holders 49
Underliners 43
Vellum 42-43
 Vermillion Bokuju Sumi 54
Walnut Ink 17, 54
 Wet & Dry Sandpaper 43
 Wheat Starch for Paste 20
 Witch Pens 40
 Wordcrafters Writing Desk 53
X-acto, See Excel, 59
Yes! Stick Flat Glue 20
Zig Markers 50
 Ziller Holders 49
 Ziller Inks 55
CD-ROMS
Book of Kells 11
Turning the Pages 11
Zapf: World of Alphabets 16
DVDS
 Copperplate
Write Like This 23
 Gilding
Gilding for Calligraphers 11
Modern Gilding for Calligraphers 11
 Spencerian
Learn to Write
Spencerian/Sull 47
Off-hand Flourishing/Sull 47
 St. John's Bible 10
GUILD ORDERS 36
RETURNS 36
SHIPPING RATES 36, 37
TEACHERS
 Class Order Discounts 36
 Letter Arts Review 9, 58
VIDEOS
 Bookbinding/Papercraft
Simply Bound/Moote
Paper Delights/Moote
 Copperplate
Write Like This 48
 David Howell 27
A Lesson with David
Pen with David

QUOTATIONS



B2681. Age doesn't matter unless you're a cheese: Wisdom from our elders by Kathryn and Ross Petras. 2002. 409pp. 4"x6". Paper **\$8.95** A collection of some of the best things that have been said about growing older from those who were already there when they said them.



B2672. Breathing on Your Own. 2004. 218pp. 5.5"x9.5". Paper. **\$18.00**
 Unlike most books of quotations, this is not a collection of familiar oft quoted words, but rather an original and deeply personal assemblage. Some of the unusual categories are: Ambiguity, Confusion, Detachment, In-Between, The Innocent Eye, Invisibility, Lock and Keys, Mirrors, Naming, The Third Alternative, and Zero. "No snowflake ever falls in the wrong place." -Zen Proverb



B2896. Love Letters to the Universe: Quotations of Astonishment and Wonder. 2005. 83pp. 5"x9.5". Paper **\$12.00**
New Explores the mystery of creation and celebrates its diversity. The selections come from myriad points of view scientific, religious, philosophical, and artistic. The quotations provoke, question, amuse, and illuminate; they tackle the big questions, but with lightness.

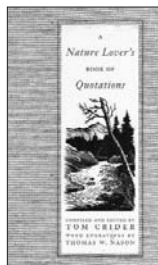

B2815. A Nature Lover's Book of Quotations compiled by Thomas Crider. 2000. 272pp. 5.25"x8.75". Hardcover \$29.00. **JNB Price \$19.95**
New An impressive selection of nature quotations from John Muir, E.B. White, Oscar Wilde, Henry David Thoreau, William Shakespeare, Plato, Barry Lopez, Thomas Jefferson, Mohandas Gandhi, Ralph Waldo Emerson, Rachel Carson and Charles Darwin

and many others. Quotations complemented by numerous wood engravings by Thomas W. Nason. Index. This beautifully produced volume makes a good gift as well as a great source of quotations! "The best book of nature quotations..." - N. Glenn Perret.

John Neal, Bookseller Gift Certificates are available in any amount from \$5 to \$5,000

To receive our free e-mail newsletter, send a request to enews@JohnNealBooks.com.

Returns: If you don't want an item that you have received, return it for exchange, credit, or refund. Used items cannot be returned unless defective. See page 36 for details. You may not need to return defective/damaged items. Please call before returning them.



B2123. The Soul Would Have No Rainbow if the Eyes Had No Tears compiled by Guy A. Zona. 1994. 128pp. 6"x6". Paper **\$10.00**

This book of American Indian proverbs was found at Ghost Ranch Calligraphy Retreat and the calligraphers quickly bought every copy the bookstore had. These are short sayings rather than long quotations.

See johnnealbooks.com for more info:

B2690. Haiku. Selected and edited by Peter Washington. Everyman's Library Pocket Poets. 2003. 256pp. 4.5x6.5. Hardcover **\$12.50**



TO ORDER

To Order: Fill in the form on page 37 and mail, fax or call in your order.

Phone Orders: 1-800-369-9598 (USA only.) 336-272-6139. Call in your order **9am-5pm ET, Mon.-Fri.** You will generally find us here until 6pm and sometimes as early as 8am. (If you plan to visit after 5pm, please call ahead.)

Please have your credit card number ready when you call.

The answering machine will take your order or message when we are not here. If you call during business hours, and get our voice mail, it means all our phone lines are busy. You can leave a message or a complete order on the voice mail.

To Fax: 336-272-9015. 24 hours a day.

Email: info@JohnNealBooks.com

Order online: www.JohnNealBooks.com

Payment: Your personal check is gladly accepted. Also Visa, MasterCard, Discover. While all prices are in US Funds, we can accept checks in Canadian Dollars and British Pound Sterling. **We offer a favorable exchange rate for Canadian Dollar Cheques & for Cheques in British Pounds. Contact us for details.** Checks in *US dollars* on a *Canadian Bank:* Add \$5 for bank charges.

To keep our shipping charges low, we use a variety of shipping methods: First Class mail, ground UPS, USPS Media Mail & Priority Mail. If you require an upgraded shipping method (UPS 2nd Day, Next Day, Express Mail, FedEx Express), you will be charged additional costs. Book and video orders may be sent media mail which can take one to two weeks or more to arrive. **If timely delivery is important, let us know so we can ship accordingly.**

Paper: Sheets of paper must be shipped separately from books and supplies. (Only large orders are shipped flat.) If you order books/supplies and sheets of paper together, you must pay shipping on the book/supply total and on the total of the sheets of paper. For example, if you order 3 books totaling \$49.95 and 20 sheets of paper totaling \$33.00, add \$7.75 shipping for the books and \$7.45 for the paper. (Pads, paper sample packets, blank greeting cards ship with books/supplies.) **See page 39 for Paper Shipping costs. Sheets of paper may arrive separately from books/supplies.**

Delivery: We pride ourselves on our prompt shipment. Most orders ship within 36 hours, but we may hold your order longer if we are out of stock of an item you want and expect the item in soon.

If you need your order by a certain date, let us know so we can put that info on your order. We can then contact you if there will be any problem with delivery.

Rush: We can often ship the same day if required. (Same day rushes need to be placed by noon ET.) There is a \$2.00 charge for same-day rush orders. *There is never a charge for rush orders caused by our error.*

Prices are subject to change without notice. We will notify before shipping if the increase is substantial.

BOOKS & SUPPLIES

Canadian and Foreign Orders. Unless you specify otherwise, we will ship your order surface. In some cases we may notify you by email of the various shipping costs. **If your order is \$50 or more we will ship it insured surface – unless you request uninsured.** Uninsured shipments are AT YOUR RISK. Packages weighing 4 POUNDS OR LESS shipped uninsured (air or surface) are considerably cheaper than insured. BOOK ONLY shipments of 6 lbs or more are a fair amount cheaper shipped uninsured. If you

Canadian and UK customers. The toll-free number does not work you, but you can ask us to call you back to place your order.

request uninsured, please state that you understand that the shipment is at your risk. **Uninsured** packages can **not** be traced. JNB will not re-ship lost **uninsured** packages. New payment in full (merchandise and shipping) will be required for re-shipping lost uninsured packages.

For all shipments your cost is based on our cost at the post office. **If you need to know the actual shipping costs, fax or e-mail us your order and request the shipping costs.** We will fax or e-mail you back with your shipping options. We will give you the cost for both air and surface shipments, insured or uninsured.

We can ship your books via Airmail, but it is very expensive. Request airmail shipping under “Special Instructions” on the form below or online.

Express shipments to foreign countries: International Express Mail is the fastest yet most reasonable international shipping method available, with delivery times usually under 4 business days. International UPS & FedEx are also available but extremely expensive (starting at \$100).

Returns: If you are not happy with any item purchased from us, package it well & return it within 15 days of receipt for a prompt re-fund, exchange, charge card credit or JNB credit. We do NOT give you credit for shipping, unless the item was sent incorrectly.

You do not need prior approval to return books or unused/unopened supplies. Let us know if you want JNB credit or refund/charge card refund. We will process your return with the same promptness that we process your order. **Send a copy of our invoice or invoice number.**

Defective books may be returned within 3 months of delivery. Used pens, opened bottles of ink, etc., cannot be returned unless defective. If it didn't work, please contact us so we can make it right by replacing or refunding.

Pack your returns in a stiff cardboard box or in a padded mailing envelope with a sheet of cardboard that extends 1" around the book on all sides.

Damaged Shipments: For United Parcel Service please notify us so we can send a replacement and file a claim with UPS. **You must save the damaged merchandise and all the packaging material.** For US Mail contact us and we will get you a replacement. We will let you know what to do with the damaged merchandise. If it was insured, you will have to file a claim with your local post office.

TEACHERS

We would like to supply your classes with the books and supplies they need. There are TWO ways to get the 10% Teacher Discount & \$8 shipping for your order.

1. Order books or supplies in quantity for your class. Order \$60 (before discount) of:

~ 6 or more of the same book *and/or*

~ 6 or more of the same ink, pen nib, fountain pen, holder, pad, and/or any other supply. (LH nibs/pens can be combined with RH to reach the minimum)

Once you meet the \$60 minimum of items ordered in quantity, you may add personal items and other items for your class to your order. You will get a 10% on all the items on your order. Your shipping costs for the entire order will be only \$8.00 (USA only). **Please request catalogs for your students.**

2. Make a group order for your class. There is no minimum per item, but your order must total \$100 before the discount. You will get a 10% discount. The shipping costs for the entire group order will be only \$8.00 (USA only).

1) For foreign class orders you are charged actual cost shipping. 2) We reserve the right to cancel items not in stock. We may choose not to backorder items we can't ship immediately. 3) You must request this discount and discounted shipping. 4) Please request free catalogs for your students to be shipped with your order. 5) Offer excludes sheets of fine papers: There is no discount and regular paper shipping applies to orders of fine papers.

FINE PAPERS FOR CALLIGRAPHERS

Except as noted all these papers have been chosen for their suitability for broad edge calligraphy. Which side is the right side to write on? The side that takes the ink the best. On laid finish papers, one side will be smoother than the other. Experiment. If you experience slight bleeding, try sumi ink or gouache on the same paper. It should work fine.

BEGINNERS: Try the inexpensive Ingres papers. Diploma Parchment is also a best bet. If you have a client that wants a 100% cotton sheet, Arches Watercolor HP is especially pen friendly.

PRACTICE ON FINE PAPER!?

A number of instructors recommend this. Why? If you only practice on practice paper, you only become accomplished at practice. Instead, think of writing on fine paper. Think of your practice always as finished pieces. You become focused in your practice – finished pieces are only more practice! Fabriano Ingres is a good “practice paper.”

SHIPPING: Because we can't ship these large sheets with other books and supplies, we charge a separate paper shipping charge. See **“PAPER ORDERING INFORMATION.”**

SAMPLE PACKAGE

Don't know what paper to order? Try our **Full Sheet Sample Pack** (PS87-SA, \$23.75). You get 8 of our most popular white and off-white sheets. Includes a good variety of both laid and smooth finish papers, both pure whites and creamy whites, thin text papers and thicker “cover weight” sheets.

PS87-SA. Full Sheet Sample Packet. A sample packet of our most popular white and off white sheets for calligraphers. Includes Arches Text Laid, Arches Text Wove, Arches Hot Press 90lb, Diploma Parchment, Fabriano Ingres White, Fabriano Ingres Ivory, German Ingres White, and Pergamenata White. These are full size sheets, not sample swatches. Each sheet is labeled in pencil. **\$23.75**

Cost includes shipping in the USA. There is no extra shipping for this sample pkt. Canada add \$5.00 (Airmail).

PS90. Arches Cover Black. Mouldmade in France. 100% Cotton. Neutral pH, lightly sized, textured surface. 250gms. 22x30. Laurie Doctor and others recommend this sheet for book, portfolio covers. It folds without cracking. \$6.50 **JNB Price \$5.50**

PS97. Arches Text Laid. 100% rag, neutral pH. 20"x25". White. Laid finish. Recommended by Peter Thornton. List \$2.65 **JNB Price \$2.05**

PS01. Arches Text Wove. 100% rag, neutral pH. 20"x25". White. Smooth finish (wove). Takes ink well and is a great, though slightly soft paper to write on. 120gm/m2. One of our most popular papers. List \$2.25 **JNB \$1.85** 10 sheets/\$1.75 each

 **Arches Watercolor.** Superior quality, 100% rag, for pen and all techniques with opaque and transparent watercolor. Long used by calligraphers. HP (Hot press) finish is a very smooth sheet that will give a sharp smooth edge to your letters. This has always been one of our most popular sheets.

The thicker weight is suitable for wash techniques.
22"x30" List JNB Price

PS42. 90 lb HP \$7.25 **\$5.95** 25/\$5.50ea

PS41. 90 lb CP \$6.95 **\$5.65** 25/\$5.25ea

PS47. 140 lb HP \$10.45 **\$8.15** 25/\$7.75ea

PS48. 140 lb CP \$10.15 **\$7.95** 25/\$7.65ea

PS21-WHT. Burga. 100% Alpha Cellulose, laid finish. 130g/m2. White. 20.5"x33" A thicker pronounced laid finish paper. Increasingly popular with calligraphers. Mould made. Germany. **\$2.55** ea.

PS84. Diploma Parchment. Machine made in the US, sulphite pulp, offwhite, pH neutral. Smooth wove finish. 17"x22". This archival sheet is a JNB bestseller. Easy to write on, a little thicker than most text weight pieces, it is great for certificates and one-off pieces. A paper you will use again & again. Give it a try. **\$1.20** sheet
10 sheets \$1.10 each
25+ sheets \$1.00 each.

Fabriano Ingres. Sulphite pulp, neutral pH. 19"x27". Laid finish. 1 deckle. Smoother finish than most laid papers. Good for beginners. Takes bottle ink well. White is the perfect creamy white. Text weight. Thinner than other Ingres.

PS02-WHI. Creamy White. **\$1.45** sheet

PS02-IVR. Ivory. **\$1.45** sheet

PS02-BLK. Black. **\$1.65** sheet

See page 59 for a pad of this paper!

PS04. Frankfurt White. This beautiful wavy laid paper is a favorite of Jean Formo. She uses it in her walnut ink classes. I find it easy to erase. Some inks allow correction with a white plastic eraser! 19x25. pH neutral. \$2.25 **JNB Price \$1.75**

PS22. German Ingres (Hanemuhle). 100% alpha cellulose. Text weight. Laid finish. 18.75"x24.75".

PS22-WHI. White. \$1.40... **JNB Price \$1.30** sheet

PS22-BLK. Black. \$1.71.... **JNB Price \$1.60** sheet

PS94. Glassine. Transparent, 100% sulphite pulp. Acid free. USA. 18"x24". **\$.75 each.** Two or more sheets \$.70 each. For use in burnishing or use it when smoothing down the paper fibers after erasing or razor scraping. Will ship with books/supplies if folded to 9"x12".

Now available in Heavy Weight and in 11x14 packets:

Pergamenata. 100% sulphite, Neutral pH. Machine made. 19.5"x27.5". 160 gsm. This parchment look sheet is a great paper to work on (much better than common vegetable parchment papers). You get the look of vellum/ parchment at a fraction of the cost.

PS88. Pergamenata. 160 gsm. Text weight. SPECIFY: NATURAL OR WHITE. 19.5"x27.5". \$3.25. **JNB \$2.40**

PS98. Pergamenata Heavyweight. 230gsm. Specify. Natural or White. 19.5"x27.5". \$3.50. **JNB \$2.85**

PS98-PKT. Pergamenata Heavyweight. Pack of 10 sheets 11"x14". 2 sheets 11"x13.5". 230gsm. Perfect size for SCA Scrolls. Ship flat with books and supplies. Easy to store, no curl to work out! SPECIFY: NATURAL OR WHITE. **\$12.95** (2pkts/\$12.50ea., 5pkts/\$11.95ea., 10pkts/\$11.50ea.)

PAPYRUS

This ancient writing surface is made by pounding together two layers of strips cut lengthwise from the rush, *Cyperus papyrus*. After drying in the sun, the writing surface is smoothed with pumice. This proto-paper was used for over 3000 years before being replaced by parchment and paper.

PS68. Papyrus. Handmade in Egypt. Approx 13"x17". Some surface texture, but accepts the ink well. The strips of reed are readily apparent in this translucent sheet. Elsewhere at \$4.00–\$8.50.

 **PS68. Papyrus:** **\$3.95** per sheet

2-9 sheets \$3.50 per sheet

10-24 sheets \$3.00 per sheet

25 or more sheets \$2.75 per sheet.

No extra/paper shipping for Papyrus.

Fabrizio Artistic (formerly Uno). Highly recommended. Relatively smooth surface – use small nib, pointed pen, or paint. Best for combining wash & calligraphy. White. 22"x30".

PS89. 90lb HP \$4.95 Natural white.

PS03-HP. 140lb HP \$6.95 Natural white.

PS03-SP. 140lb Soft Press \$6.95 Bright white.

See *Bound & Lettered* 3.4 for info on this paper.

Paper Ordering Information

Because of their large size, sheets of paper cannot be combined with book/supply orders for shipping. Only large orders of paper are shipped flat. If you combine a *Paper Sheet Order* with a *Book/Supply Order*, please add the additional "*Paper Shipping*." That is, first total the books/supplies & figure the shipping on those. Then total the cost of the paper sheets & add *Paper Shipping*.

PAPER SHIPPING: USA

Add \$6.95 for orders to \$30.00

\$7.45 for orders to \$40.00

\$7.95 for orders to \$50.00

\$8.45 for orders to \$60.00

\$8.95 for orders to \$70.00

\$9.45 for orders to \$80.00

\$9.95 for orders to \$100.00

Larger orders add 10% for shipping.

PAPER SHIPPING: INTERNATIONAL

Airmail only in tubes designed to ship paper. Shipping cost starts at about \$8.00 for Canada and \$18.00 all other countries. Please inquire about exact costs, as even smaller quantities of paper become expensive to ship overseas.

PLAIN PADS

Boris Layout Pad. Bright White Felt Marker Layout Pad (#37). A smooth, translucent sheet that is highly recommended. No bleeding or feathering. Popular for beginning classes, and for copperplate for reproduction. Our most popular pad.

50 shts 100 sheets

P10. 9"x12" \$5.25 \$8.50

P11. 11"x14" \$7.25 \$11.75

P12. 14"x17" \$9.95 \$16.50

Canson Pro-Layout Marker Pad. A bright white, 18lb, rag marker layout pad. 50 sheets. Very smooth surface. Worth the price. Black guidelines under the sheet are easily seen even without a light table. *Michael Sull's favorite pad for work for reproduction. His recommendation is echoed by other scribes and penmen: "Absolutely wonderful." "A great pad."*

P32-9. 9"x12" \$10.25 P32-11. 11"x14" \$14.00

P32-14. 14"x17" \$19.45

JNB Practice Pad. Smooth surface white sheet. Guidelines will show through. Good for classes and practice (20 lb bond). Pads approx. 50 & 100 sheets.

P19. 8.5"x11" 100 shts \$6.25

P19-Ream. 8.5"x11". 500 shts unpadding. \$19.95

P20-50 / -100. 11x17". 50shts \$6.50 100 shts \$11.95

P20-REAM. 11"x17". 500 sheets \$39.95

P26. Papier Japon. 9.5x12" \$22.00 P27. 12x16" \$31.00.



Pentalic Paper for Pens. Archival Quality, neutral pH, 110lb, smooth hard surface. 40 sheet pad. Use this pad for crisp lettering. Bright white. Back when it was produced by the pioneering calligraphy supplier, Pentalic, this was a favorite with scribes. The paper has recently been brought back up to those earlier high standards.

P17-9. 9"x12". \$9.99 P17-11. 11"x14". \$12.99

P17-14. 15"x17". \$18.99



Strathmore Series 400 Drawing Pads.

80lb acid-free paper for pen and ink and light washes. Regular/Medium surface.

Offwhite. 24 sheets. Thomas Ingmire uses these in his workshops as a less expensive alternative to *Arches Text Wove*.

P100-9. 9"x12" \$5.80

P100-11. 11"x14" \$7.85 P100-12. 12"x18" \$8.70

P100-18. 18"x24" \$17.50 2/\$16.50ea 3/\$15.50ea

P04. Canson Calligraphy "Parchment" Pad. Works well with ink including fountain pens (and also laser and inkjet printers). The traditional mottled parchment look. 8.5"x11". Acid-free. *Assorted pad:* white, natural, gold. 50 sheets. **\$10.20**

Clairefontaine, Ampad Embassy & Spencerian p48

GRIDDED PAD / NON-PHOTO BLUE

All are generally 11"x17", approximately 50 sheets with a non-reproducible grid, 8 squares/inch. Grid may show up on some copies.

P01. Copperplate Grid Pad. See page 46. **\$7.95**

P21. JNB Graph Pad. Non-repro grid (8sq/inch). 20 lb bond. 11"x17". Grid lines may show with some inks.

Approx 50 sheets. **\$7.50 6/\$7.25 12/\$6.95 24/\$6.75**

P23. Westwind Graph Pad. 11x17, 50 sheets **\$13.95.**

This popular pad is available once again! Through extensive testing of paper, inks and printing process they have now produced the highest quality pad ever. The blue non-repo grid is accurate and does not "ghost" through the written letters.

MISCELLANEOUS

S478. Ball Burnisher. \$2.99

M31. Chartpack Blender Marker. \$3.79

S134. Krylon Workable Fixative. 11 oz. \$8.95

S120-30. 30 Well Plastic Mixing Tray. \$1.60

Pebeo Drawing Gum. The best masking fluid. Write with the masking fluid in your pen. Let it dry, apply a watercolor wash, let it dry, and remove the masking fluid with a Rubber Cement Pick-up. You have white letters on a color background. Thins and cleans with water. **S198-1. 1.5 oz. \$6.25 S198-8. 8.45 oz. \$20.15**



S141. Pipets. 10/\$2.25

50/\$8.25 100/\$14.95

These pipets function like eye droppers. Use them to store mixed gouache for later use. (As when a customer is expected to ask for more envelopes done in a mixed color a few days after you completed the first batch.) For airtight, longer storage, the end can be sealed quickly with an iron. Soft plastic (polyethylene), 6" long. Cut the end to use.

S363. Bunch of Brushes. 24 cheap brushes. **\$8.25**

S407. Mixing Brushes. Sml, Med, Lrg. Cheap brushes. **\$.50ea**

S140. Plastic Dropper Bottle. 30ml. **\$3.10**

S199. Rubber Cement Pick-up. \$1.95

S454. Repositionable Glue Stick. \$2.45

S411. White Artist's Tape. Acid Free. 3/4"x 10yd. **\$2.85**

TEACHERS: Please introduce *Letter Arts Review* to your students – and maybe to yourself as well. When you take advantage of our special *Letter Arts Review Teacher Offer* you get a great deal and your students get a great magazine at a great price. Send in five student subscriptions (in a single envelope) and we will give you, the teacher, a free subscription, a continuation of your subscription, or a gift subscription for someone of your choice. Contact us for details and a sign up sheet.



NIBS

The standard nibs for broad edge pen work are: Tape, Brause, Mitchell Round Hand and Speedball. Any of them will work well. Which is best?
Best quality: BRAUSE Most flexible: MITCHELL

Brause Nibs



N02. Brause Nibs. Stiffer nibs with reservoir on top. Oblique cut. Sizes: .5, .75, 1, 1.5, 2, 2.5, 3, 4, 5mm.

High quality nibs from Germany. If you have a heavy hand, these will work well.

N02-S9. Set of 9. List \$17.00. **\$13.00**

N02. Individual nibs. Specify size.

List \$1.70 JNB Price. **\$1.45** 10 or more asst, **\$1.35** ea. 50 assorted.... **\$62.50**

N06. Brause Left Hand Nibs. Hand ground to left oblique.

N06-S9. Left Hand set of 9. **\$22.50**

N06. Left Hand nibs. **\$2.80** each

10 or more assorted LH Brause.. **\$2.50** ea

Hiro Tape Nibs



N01. Tape Nibs. These are more flexible than Brause nibs but stiffer than Mitchell and take to the ink better when new. Reservoir on top. Right Hand sizes only: .5, 1, 1.5, 2, 2.5, 3, 4mm. Oblique cut.

A good nib for classes and beginners.

N01-S7. Set of 7. List \$7.00. **\$6.50**

N01. Individual nibs. Specify size. List \$1.05. **\$.95**

10 or more assorted **\$.90** ea. 100 or more **\$.85** each

New **N19. Manuscript Roundhand.** These nibs are similar to Mitchell Rexel Roundhand but a bit stiffer. Bronze. Sizes: 1, 1.5, 2, 2.5, 3, 3.5, 4, 5, 6. **\$.75**ea 10/**\$.65**ea 100/**\$.60**ea Also called *Hiro Rond*.

N19-S9. Set of 9. **\$6.00**

"Manuscript pens recently produced their bronze, instead of their gilt, nibs and a group of Calligraphy & Lettering Arts Society members tested them. Whereas everyone had hated the gilt ones, the bronze ones were approved by everyone. Gaynor Goffe approves of them too, but still likes the Mitchell Roundhand nibs as well."

— Lorna Bambury, Great Bookham, England

Speedball Nibs

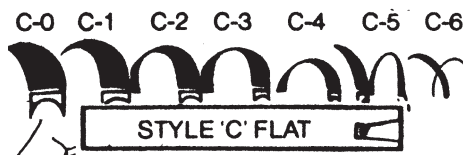

Speedball. American nibs. C-0, C-1, C-2, C-3, C-4, C-5, C-6. *C-0 is largest, C-6 is smallest.*

Best in larger sizes. C-2, C-3, & C-4 are popular for beginners' classes. **N09. Individual nibs.** **\$1.99**

N09-S6. Set of 6 (C-0/C-5). **\$10.59**











Speedball Left Hand Nibs.

Sizes LC-0, LC-1, LC-2, LC-3, LC-4.

N10. Individual nibs. **\$2.55** **N10-S5. Set of 5.** **\$12.95**

N16. Speedball B Series. Specify size: B0, B1, B2, B3, B4, B5. **\$1.90**ea.

Mitchell RoundHand Nibs

No. 0 (3.3 mm) 	No. 3 (1.4 mm) 
No. 1 (3 mm) 	No. 3 1/2 (1 mm) 
No. 1 1/2 (2.5 mm) 	No. 4 (0.9 mm) 
No. 2 (2.3 mm) 	No. 5 (0.75 mm) 
No. 2 1/2 (1.8 mm) 	No. 6 (0.6 mm) 



N04. Mitchell Rexel Round Hand Nibs. Flexible nibs from England without reservoirs (see below). Straight cut. Sizes 0(3.3mm), 1(3mm), 1-1/2(2.5mm), 2(2.3mm), 2-1/2(1.8mm), 3(1.4mm), 3-1/2(1mm), 4(0.9mm), 5(.75mm), 6(.6mm)

Though they say round hand, these nibs are very suitable for all broad edge alphabets. Beginners may have some trouble with the flexibility.

N04-S10A. Set of 10 w/ 2 res. **\$8.60**

N04-S10B. Set of 10 w/ 10 res. **\$12.95**

N04. Individual nibs. Specify size. List \$1.45. **\$.80**

10 or more assorted Mitchell **\$.75** each

Gross (144) (same size). **\$85.49**

Mitchell Left Hand Nibs.

N05-S10A. Set of 10 w/ 2 res. **\$8.60**

N05-S10B. Set of 10 w/ 10 res. **\$12.95**

N05. Individual nibs List \$1.45 **\$.80**

10 or more assorted LH Mitchell. **\$.75**

N07. Mitchell Slip on Reservoirs. These slide on under the nib. You may need to adjust them slightly, but this is no problem as the metal bends easily.

List \$1.15. **\$.62** 10/ **\$.56** each. Gross box (144) **\$52.00**

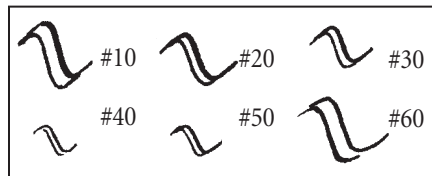

Scroll Pens

N11. Scroll Pens. A dip pen that writes a double line. Mitchell (Rexel). No reservoir. Specify 10, 20, 30, 40, 50, 60. List \$3.55 **N11. Individual nibs.** **\$2.99**

N11-S6. Set of 6. **\$16.75**

Witch Pens

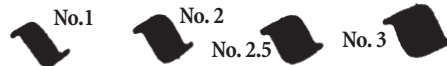

N15. Mitchell Witch Pens. Square cornered, but with rolled over writing edge which allows pen to glide over rough surfaces. Works well on grained or coarse paper. Pen is a complete unit with nib, reservoir and holder. Sizes: 1, 2, 2.5, 3,

N15-S4. Set of 4. List \$26.75 **\$10.25**

5-Line Pens



N39. Brause 5 line Music Nib. Width of whole nib 13/16". **\$2.50**



N28. Automatic Pen 5-line. Designed to produce lines for sheet music, calligraphers use it to produce light, five stroked letters. **\$10.95**

Nib Sharpening

S106. Crocus Cloth. \$1.50 **S107. Polishing Paper \$2.50**

Both are used in the final smoothing of a broad edge nib. The polishing paper can also be used in finishing a hematite burnisher.

S115. Hard (Black) Arkansas Stone. For sharpening your nibs. Instructions included. **\$19.95**

Magnifier

Reggie Ezell recommends a 10X magnifier for checking nibs as you reshape ("sharpen") them. They are also useful for reading the small writing on pointed nibs and to check the tips for quality of point. **S508.**

Magnifier. 10x. Plastic. **\$9.95**



NIB ORDER DISCOUNTS

☞ **Individual orders:** If the broad edge NIB total (Brause/Tape/Mitchell), of your order is \$100 or more, take an **additional 10%** off the broad edge nib prices.
 ☞ **Teachers** See page 36. ☞ **For both individual & teachers orders, the 10% discount is off any applicable quantity prices.**

ERASERS/PENCILS/CASES

E08. Factic. Black Eraser. For erasing pencil lines on black papers! Does not leave marks. **\$.99 ea.**

E09. Kneaded Eraser. \$1.00

S86. Magic Rub Eraser. For erasing pencil guidelines. Non abrasive. **\$1.00**

S142-XX. Drawing Pencils. Design 3800. "6H" is hardest lead. "5B" is softest lead, Specify 6H, 5H, 4H, 3H, 2H, HB, 2B, 3B, 4B, 5B, **\$1.25**

S410. Flat Point Pencil Sharpener. This new sharpener creates a chisel point on all types of pencils. **\$8.98**

S362. Pen/Brush Rollup. A black nylon roll-up style brush holder with velcro closure for long handle brushes. Excellent for penholders, brushes, Auto Pens, etc.

Snap hook for attachment to portfolio and cover to hold brushes secure. Has 12 pockets. Holds 12 to 18 tools. Open size: 16"x18.5". **\$11.95**



S231. Pen & Holder Bin. A thin case of unbreakable clear plastic to with four compartments for nibs and one for holders. 7"x3.5"x1.25". **\$7.50.**
JNB Price \$6.50

Automatic Pens

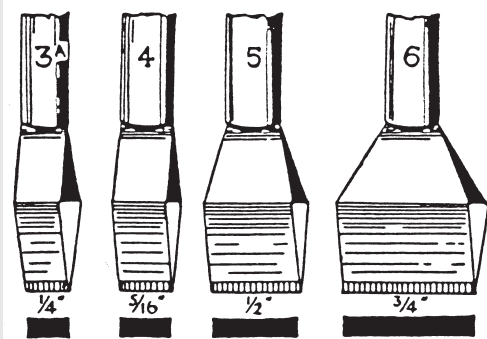

N27. Automatic Pens. These poster pens are made of a non-rust nickel silver with a plastic handle. They produce very thin thins. Use them with the tooth blade uppermost. Clean with warm water after use. A new pen should be filled and worked gently on paper until the color (ink) flows. Any possible sign of scratching will soon wear off with use. **\$10.95**

N27. Automatic Pens

Sizes: 1 (1/16") 2 (1/8") 3 (3/16") 3A (1/4")
 4 (5/16") 5 (1/2") 6 (3/4") 6A (1") **\$10.95 ea.**
Set of 6 pens \$62.50 (sizes 1, 2, 3or3A, 4, 5, 6)

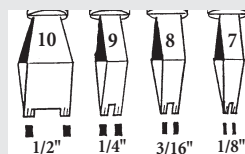

N27. Scroll Automatic Pens
 Specify: #7, #8, #9, #10. **\$10.95 each**

HOLDERS

Our most popular holder is the Grey Plastic. I'm told it's Ieuan Rees' favorite holder. Peter Thornton recommends it, too. **TEACHERS** note the quantity prices on Black Wood Holders.

H35. Black Wood Holder. Black painted wood holder, metal interior collar, metal grippers. **\$1.20** 10/\$11.00 30/\$31.50

H32. Brause Double Nib Holder. All wood holder that accepts a nib at each end. No metal parts to rust. 6-sided staff. **\$4.50** **JNB Price \$4.20**

H76. Cigare Penholder. For those who want a thicker holder. Dark wood. **\$5.50**

H38. Cork Tip Holder. Black lacquered wood holder with cork finger grip. Interior metal collar & metal grippers. **\$4.85**

H39. Double Nib Holder. You can insert a nib in each end of this short holder. A smooth cylinder, not faceted. Interior metal collar, metal grippers. 4.75". **\$1.50**

Moving? Send us your change of address. The post office will **NOT** forward our catalog to your new address.



H77. Ergonomic. Shaped to reduce fatigue and discomfort. Blond wood. **\$5.50**

H46. Grey Plastic Holder. Lightweight grey plastic (Caran D'Ache 114) holder with a unique metal gripper. We had tried for years to stock these holders. They come all the way from Switzerland! They are usually a sell out at local workshops. **\$1.80** 10/\$17.50

H69. Hunt Plastic Holder. An all plastic holder with hourglass shape. **\$1.39**

H49. Universal Penholder. Made of a clear plastic rod with a soft plastic sleeve to hold the nib. The soft sleeve also acts as a cushioned finger grip. No metal parts to rust, easy to clean and very lightweight. Works with any nib except crowquills. **\$2.30**

See page 53 for more holders.

See page 49 for oblique holders.

Letter Arts Review back issue & subscription info, see page 58.



INKS

See page 51 & 54-55 for more inks.

Beginners need a non-waterproof ink such as **Higgins Eternal** for dip pen use. While other inks are blacker, Higgins Eternal is easy to use and is inexpensive. Some inks like the sumis are more water resistant & others, like **Calli** and **FW Inks**, are actually waterproof.

For FOUNTAIN PENS use only inks that say on the bottle that they are for use in fountain pens. Dye inks (such as Pelikan 4001) flow dependably and are good for correspondence and roughs. Though waterproof, Calli is designed for fountain pens. Unless the bottle says an ink is suitable for fountain pens (not technical pens) it may clog your fountain pen and perhaps ruin it.

I38. Dr Martin's Bleed Proof White. A dense, opaque smooth writing white for your dip pen. Thin with water to the proper consistency. Tint with watercolor or gouache for pastel letters. Recommended by John Stevens and Peter Thornton. 1oz. **\$7.40**

I13-028. FW Artist Ink Black.

I13-011. FW Artist Ink White.

An acrylic based pigmented water resistant ink. Opaque and permanent (lightfast). 1oz jar. **\$6.00**



I08. Higgins Eternal. A non-waterproof, carbon black ink for dip pens. A good bet for beginners. Our most popular ink for classes. Recommended for copperplate (add a few drops of gum arabic) 2.5 oz. **\$3.00 ea.** 6/\$2.95 ea. 12/\$2.85 ea.

I88. Iridescent Medium. An easy way to add some sparkle to your projects. Mix with wet gouache or watercolor or apply on dried watercolor areas to produce an iridescent effect. Easily diluted with water. Gum Arabic binder. 2oz. Plastic jar with screw top. **\$6.55**



I02. Pelikan Fount India. A dense carbon black ink suitable for fountain pen and dip pen use. Non-waterproof. Good for beginners. 1oz. **\$5.50**

I62. Pro-White. Sherrie Lovler's white of choice. Also mixes well with gouache. **\$6.95**

I69. Matte Black Winsor & Newton Calligraphy Ink. 30ml. This special matte black ink is only for dip pens and brush. Not for fountain pens. **\$4.95** "The winner for the most densely black non-waterproof ink." -Corinna Taylor

Sumi

If you have been using Higgins Eternal and want something blacker, try one of these sumi inks. The Squarish Green Bottle Sumi is the easiest to write with and the closest to Higgins Eternal.

I22-2. Bokuju Sumi. A shiny, dense black ink. A very popular ink. Will eat your nibs. "Green Bottle Sumi." Fairly slow drying. 2oz. **\$4.40**

I22-12. Bokuju Sumi. A 12 oz bottle. **\$12.30**

Squarish Green Bottle Sumi. A dense black waterproof sumi ink. More free flowing than Bokuju or Yasutomo Sumi but not quite as densely black. Similar to, but blacker than Higgins Eternal.

I39-2. 2oz bottle. **\$5.50**

I39-6. 6oz bottle. **\$8.50**

I39-12. 12oz bottle. **\$14.00**

Yasutomo Sumi. Matte black. Comes in a tall rectangular black bottle. **I24-2.** 2oz bottle. **\$4.80**
I24-6. 6oz bottle. **\$8.00**

IS37. Round Ink Stone **\$14.99**

IS38. Hexagonal Ink Stick. **\$9.99**

IS39. Ink Stone/Ink Stick Set. **\$22.50 Save \$2.50!**

See page 60 for descriptions. See page 44 for more sticks.

REAL LEAF

A book is a packet of 25 leaves of thin material. **Loose Leaf** is pounded and packed between sheets of rouged paper. It must be lifted from the paper with a wide brush called a gilders' tip or placed on a specially made **Gilder's Cushion** for cutting. **Patent Gold** is loose leaf placed on a tissue paper which is then placed under pressure to adhere it to the tissue. Patent leaf can be cut with a clean pair of scissors, and applied, gold side down, onto a prepared surface.

S188. Loose Leaf Gold Leaf XX 23K. Book 25 shts. **\$43**

S189. Patent Gold Leaf XX 23K. Book 25 shts. **\$46.00**

S159. Shell Gold. 22 carat. Small tablet. **\$25.00**

S577. French Gold Powder. Vivian Mungall uses this real gold powder in place of shell gold. 1 gram container. **\$65.00**

IMITATION GOLD / LEAF

Patent Non-Precious Metal Leaf. Patent True Gold Leaf out sells Loose Gold for us 10 to one. The reason is simple, the leaf is so much easier to work with because of the paper backing. We have recently located a source for patent imitation gold, imitation silver (aluminum) and copper leaf.

S458. Patent Non-Precious Metal Leaf. Book of 25 sheets. Leaves measure Approx 5.5"x5.5". Specify Gold, Aluminum, Copper. **\$15.50 ea.**

VELLUM

Vellum is the ultimate writing surface for a scribe. While most of us write on paper, we can still write on the same material used for all the treasured medieval manuscripts. You can feel a connection with the scribes and illuminators of the Book of Kells, The Lindisfarne Gospels, The Ramsey Psalter. High quality vellum is somewhat translucent and will have natural variations. Remember that vellum is the most forgiving of all surfaces for corrections.

Calfskin Vellum Scraps: These are small and irregular pieces, generally long and narrow. Not prepared. These pieces are smaller than vellum offcuts and some are from the edge of the skin.

S152. Bag of 3-4 pieces of varying sizes. **\$4.75**

S152-1/4. 1/4 lb bag. **\$13.50**

S152-1/2. 1/2 lb bag. **\$24.95**

S152-1. 1 lb bag. **\$47.95**

We counted one of our 1 lb. bags. There were 90 pieces plus some scraps too small to use.

Calf Skin Manuscript Vellum. Medium weight. Our vellum sheets are expertly prepared on one side for writing. These sheets are ready for you to put pen or quill and ink or gouache to vellum! *Specify size:*

S197-4. 4"x6" **\$ 9.75**

S197-6. 6"x8" **\$18.50**

S197-8. 8"x10" **\$32.00**

S152-FUL. Full Skin. Classic Calfskin Vellum. Prepared for writing. Approx. 5-8 sq.ft. per skin. **\$40.00** per square foot.

S152-HAL. Half Skin of Classic Calfskin Vellum. Prepared for writing. **\$42.50** per square foot.

S319. Fine Dental Pumice. Used for de-greasing vellum for writing. 1oz. **\$2.00** 6/\$1.75ea 20/\$1.50ea

Gum Sandarac. Used on vellum and paper just before writing to achieve fine hairlines. **S123-1. 1.0oz. \$7.25** **S123-1/2. 0.5oz. \$4.50** **S123-B. Bag. \$7.25** *see below*

Wet & Dry Sandpaper. Used raising the nap in preparing vellum for writing.

S316. 320 Grit \$1.25 **S317. 400 Grit \$1.25**

GILDING SUPPLIES

S428. Titanium Dioxide. 1 oz. \$3.00

S455. Gilders Bole. Powder. Adds a deep red color to gold. **1/2 oz. \$ 3.50** **1 oz. \$6.00**

S414. Calcium Sulfate Dihydrate. Finest grade.
1 oz./\$11.00 **2oz./\$20.00** **4oz./\$32.00** **16oz./\$112.00**

I44. Fish Glue. 2oz. \$5.00

S251. Prepared Gesso Tablet. Gesso. Contains white lead (a poison). Handle with appropriate care. Instructions included. **\$13.75** 2/\$13 ea.

S267. Gilder's Cushion. 5.5"x5.5". **\$20.00**

I86. Gum Ammoniac. Soak these crystals in water and strain to produce a base for laying gold. 1oz jar. **\$4.50**

S479. Instacol. Yellow color. 100ml. Reggie Ezell loves this gold size for mirror finish gilding. It is so easy! Yellow color allows you to see what you have applied. Directions included with your order. **\$14.95**

I90. Liquitex Gloss Medium & Varnish. \$7.95

S473. Tresser Gold Size. Use this pink liquid for flat gilding on paper or most any surface. Highly recommended for its ease of use. **\$6.00**

M40. Sailor White Rolling Ball Pen. Use this opaque white pen for making small dots in dark backgrounds in illuminations, for drawing white lines, and as a white-out for paste-ups for reproduction. **\$3.29**

S386. Hot Foil Pen. \$12.95

S387. Hot Foil Pen Refills. \$2.95

See page 38 for glassine.

See 53 for hemitite burnisher & jewelers rouge.

GUIDES & RULERS

Pre-ruled guidelines save time – no guidelines to draw and none to erase. For practice paper and other thinner sheets, guidelines on paper work well. Thicker or colored paper will require a light box and guidelines on clear material. Most of our guidelines consist of sheets of equally spaced lines.

GL04. Letterlines Guidelines. A set of 14 different guidelines printed on thick 11" x 17" paper. Includes one guideline sheet for Copperplate. Use with or without a light box. Includes a pen size chart that identifies similar pen sizes among different dip and fountain pens. **\$19.95**

GL03. Translucent Letterlines Guidelines. Set of 5 translucent, 11" x 17" guidelines with a 5° slope guideline. Durable plastic. 5 pen-widths between guidelines for pen sizes: XF, F, 3/4mm, 2-1/2mm and 3mm (C2). **\$15.95**

GL06. Envelope Guidelines / Letterlines. Slip these guidelines into your envelopes. Two sets of lines (large, small) 7" wide x 5.25" long. Printed on clear plastic. Includes an envelope template for making your own envelopes using gift wrap and other paper AND an addressing guide with tips and creative ideas along with etiquette for addressing envelopes. **\$9.50**

See page 34 for index

GL07-S6. Underliners. A set of six guidelines on a clear film (Fine, Medium, Broad, B2, B3, B4). 8.5"x11" Can be cut to fit in envelopes. **\$7.95**

GL08. Pen Notes Envelope Guides. Italic, Blackletter/Uncial, and Copperplate for #10 (business) envelope printed on translucent plastic. **\$6.00**

S91. Ames Lettering Guide. \$2.95

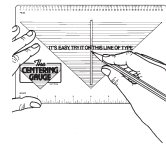

S144. The Centering Gauge. This simple but effective tool makes finding the center of a line quick and easy. Use it when you are trying to center a series of lines. **\$10.95**

RULERS

S425. 18" Centering Ruler. \$5.75

S575 Linux Ruler. A very accurate non-skid, 20" plastic ruler imported from Denmark. Mm and 1/16" inch measurements are etched on clear plastic. Recommended by Reggie Ezell for its precision markings. **\$10.95**

New **Deckle Edge Ruler.** When you tear paper instead of cutting it you get a softer edge, but you don't get the irregularities of the deckle edge of a handmade sheet. However, by tearing your paper against the deckle edge of these rulers you get a deckle edge on your paper. Steel with millimeter and 1/16" guides. Three sizes available:

S263. 18 inch. \$29.95

S230. 12 inch. \$19.95

S264. 6 inch. \$12.95

S385. 12" Rolling Ruler. \$8.50

Stainless Steel Ruler. Flexible, cork back.

S270. 12" \$3.15 **Sale \$3.05**

S271. 18" \$4.25 **Sale \$3.95**

GUMS

I84. Gum Arabic. A binder. Add several drops to a bottle of Higgins Eternal for copperplate writing. Also used with gouache. 2.5oz (75ml). (W&N). **\$12.55**

I85. Gum Arabic Powder. Add 7 parts distilled water to one part powder or add to bottled ink directly. 1oz. **\$3.50**

S123. Gum Sandarac Powder. Tie up in a small square of cotton cloth, and lightly pounce onto your paper to produce finer thins. Will help produce crisper letters. May stop bleeding, feathering.

S123-1. 1.0oz. \$7.25 **S123-1/2. 0.5oz. \$4.50**



S123-B. Gum Sandarac Bag. A bag of ground gum sandarac ready for you to use to correct slight bleeding or to get thinner thins. Dab the sandarac onto the paper through the cloth & then hold the paper vertically and tap off any excess. **\$7.25**

Guild Orders: We offer a 10% discount and \$8.00 shipping (in the USA) for group orders by guilds. We are happy to send a quantity of catalogs for you to distribute. One large order is placed. We then ship the items to your guild and you distribute the items to your members that have ordered. The order must all be sent to one address. There are also some minimums. Contact us for details.

WATERCOLOR

Winsor & Newton

WN678. Venetian Red. Venetian red pigment is especially easy to use in a pen. **\$8.20**

For illumination, Sheila Waters recommends watercolor rather than gouache. Here is her double primary set. For mixing, you need only one warm & one cool red, one warm & one cool blue, medium yellow, white and black. 5ml tubes. Sheila has suggested colors with a high permanence/lightfastness.

⇒ WARM RED – any orangy-red. You only need one.

WN683. Vermillion Hue \$10.35

WN603. Scarlet Lake \$9.25

WN004. Alizarin Crimson \$8.20

⇒ COOL RED – any purplish red. You only need one.

WN502. Permanent Rose. \$10.35

WN548. Quinacridone Red. \$10.35

WN097. Cadmium Red Deep. \$12.15

⇒ WARM BLUE – any purplish blue. Only need one.

WN263. French Ultramarine Blue \$9.25

WN178. Cobalt Blue. \$12.15

⇒ COOL BLUE – any greenish blue. Only need one.

WN137. Cerulean Blue \$10.35

WN 719. Winsor Green Blue Shade. \$8.20

⇒ MEDIUM YELLOW – you only need one.

WN108. Cadmium Yellow. \$12.15

WN730. Winsor Yellow. \$8.20

⇒ WHITE – for dots and fine lines.

WN644. Titanium White \$8.20

WN150. Chinese White. \$8.20 for mixing/tinting

⇒ BLACK – Ivory black is the best!

WN331. Ivory Black \$8.20

Graham Watercolor

Nancy Culmone's favorite Watercolors are M Graham colors. One reason she likes them is that they can be reconstituted in the palette after they dry. Calligraphers appreciate the 1/2oz tubes (15ml) – for the price of the smaller 5ml Winsor & Newton tube. They are brilliant and semi-opaque, about halfway between gouache and transparent watercolor. They are made with honey which provides for a smoother flow.

Manufactured by a small company in the Pacific North West. Instead of using Chalk for opacity, they have increased the pigment in the tube! Made with honey for smooth flow. They have been well received by calligraphers.

M GRAHAM WATERCOLOR. 15ml tube

Purchase 6 or more tubes take 30% off

Series 1. \$9.69. 30%off \$6.80.

Series 2. \$10.49. 30%off \$7.35

Series 3. \$11.49. 30%off \$8.05

Series 4. \$16.99. 30%off \$11.89

Code Color Series

010 Alizarin Crimson 2

018 Azo Yellow (Spectrum) 2

020 Burnt Sienna 1

030 Burnt Umber 1

038 Cadmium Orange 4

040 Cadmium Red 4

050 Cadmium Red Lt. 4

060 Cadmium Yellow 4

070 Cad. Yellow Lt. 4

080 Cerulean Blue 3

085 Chinese White 1

090 Cobalt Blue (Spectrum) 4

100 Dioxazine Purple 3

105 Gamboge 2

108 Hooker's Green 2

110 Ivory Black 1

112 Lamp Black 1

120 Naphthol Red (Spect.) 2

Code Color Series

122 Neutral Tint 1

128 Payne's Gray 1

130 Permanent Green Lt. 2

140 Phthalocyanine Blue 2

150 Phthaloc. Green 2

153 Prussian Blue 2

155 Quinacridone Red 3

156 Quinacridone Rose 3

158 Quin. Violet (Spect.) 3

160 Raw Sienna 1

170 Raw Umber 1

174 Sap Green 2

178 Sepia 1

190 Ultramarine Blue 3

193 Ultramarine Violet 3

195 Viridian 3

200 Yellow Ochre 1

GOUACHE

See page 56 for Winsor & Newton & Schmincke gouache

For brilliant & opaque letters in color, use gouache. Add distilled water, one drop at a time, mixing with a brush until the consistency is a little thicker than bottled ink. Most problems come from mixing gouache too thick. Rake the brush across the side of the pen to fill the reservoir. Try a few letters. You can only know if you've reached the correct consistency by writing. When the consistency is flowing nicely, add one drop of gum arabic. This is a binder which will help the gouache adhere to the paper. When you erase pencil lines, the color won't smear or pale. ZINC WHITE is recommended for MIXING with other colors. Use PERMANENT WHITE when you want an OPAQUE white.

MORGENTHALER & GRAHAM GOUACHE 15ml tube

	List	30% off
Series 1	\$6.99	\$4.89
Series 2	\$7.89	\$5.55
Series 3	\$10.29	\$7.20
Series 4	\$15.49	\$10.85

Sale! Okay to mix Watercolor and Gouache for discounts

Purchase 6 or more tubes take 30% off

Code Color Series

010. Alizarin Crimson 2

018. Azo Yellow (Spectrum) 2

020. Burnt Sienna 1

030. Burnt Umber 1

038. Cadmium Orange 4

040. Cadmium Red 4

050. Cadmium Red Lt. 4

060. Cadmium Yellow 4

070. Cadmium Yellow Lt. 4

080. Cerulean Blue 4

090. Cobalt Blue (Spectrum) 4

100. Dioxazine Purple 3

105. Gamboge 2

107. Hansa Yellow (Primary) 2

108. Hooker's Green 2

110. Ivory Black 1

112. Lamp Black 1

120. Naphthol Red (Spect) 2

Code Color Series

128. Payne's Gray 1

130. Permanent Green Lt. 2

140. Phthalocyanine Blue 2

150. Phthalocyan. Green 2

153. Prussian Blue 2

154. Pyrrol Red (Primary) 2

155. Quinacridone Red 3

156. Quinacridone Rose 3

158. Quin. Violet (Spect) 3

160. Raw Sienna 1

170. Raw Umber 1

174. Sap Green 2

180. Titanium Whi. (Perm) 1

190. Ultramarine Blue 2

195. Viridian 3

200. Yellow Ochre 1

205. Zinc White 1

INK STICKS

Japanese Ink Sticks. These are high quality ink sticks from Japan's most respected ink stick maker. All come in a individual wooden box. Ewan Clayton, a master scribe from England, tested their full range and choose these ink sticks for calligraphy. His description and comments are given for each stick. Available January 2007.

Student Quality

IS03 Kenbimukan. Brownish Black. Student Grade. Gives sharp and crisp strokes. The least expensive stick suitable for western calligraphy. Made from mineral oil. **\$20.00**

Professional Quality Ink Sticks

IS04. Gansui. Bluish Black. Made from different size soot particles which gives the blue black color. Flows well from the pen, basically matt (with the nearest hint of sheen). Works well when dark or diluted. **\$30.00**

IS05. Mujokokuhin. Reddish brown black. Slight sheen, very smooth flow. Good for small scale writing. Slightly denser than Gansui. Made from vegetable oils. **\$50.00**

IS06. Skakyozumi. Densest black of these ink sticks (hinted slightly toward red brown). Glossy when thick. Made from Vegetable oils. **\$30.00**

IS07. Ranjatai. Bluish Black. Made primarily for painting but also good for calligraphy. Works well thick (dense black) and when watered down it moves out into wet paper in a very subtle way. **\$40.00**

IS08. Eiraku. Reddish Brown Black. Dense black. Smallest size of all the ink sticks. Top quality ink stick, but for Ewan Mojokokuhin is a better value. **\$40.00**

Long unavailable & highly prized by calligraphers

IS02. Natural Shaped Suzuri (Otome Stone) (50102-S) \$35 each. Limited supply. Only 9 available.

See www.johnnealbooks.com for colored ink sticks from Japan.

JARS

S260. Widemouthed Plastic Jar with lid liner. Similar to old Ziller Ink containers. Use to mix & store colors. 1 oz. **\$1.00** 5/\$.75 10/\$.65 20/\$.60 30/\$.55 each

S276. Widemouthed Glass Jar. 1 oz. \$2.00





S365. Easel Tote. Use this to carry your easel/plexi and pad of paper to classes and workshops. Water resistant black nylon fabric. Two zippered pouches on outside allow for carrying tools. Carrying handles and an adjustable shoulder strap. Great price. 24.5"x28.5". Similar ones sell for \$25-\$30. **JNB Special \$22.50**

Frosted plexiglass for easels. 1/8" thick

S160-L. Large Plexi. \$13.50

S160-S. Small Plexi. \$9.95

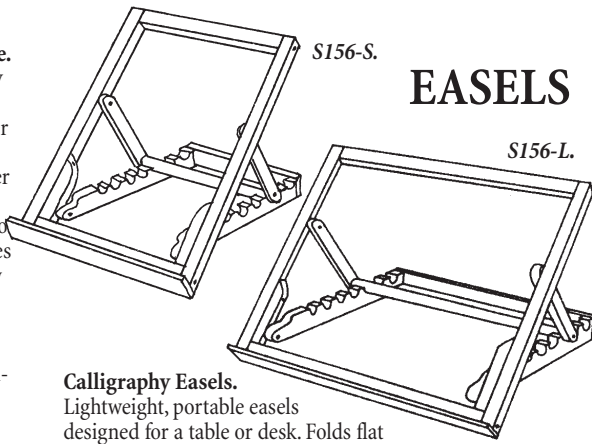

EASELS

Calligraphy Easels.

Lightweight, portable easels designed for a table or desk. Folds flat to 1.5" thick for easy carrying. Adjustable to 7 different angles. Can be used as a light table.

S156-L. Large. 23" wide, 19" high. **\$36.95**

S156-S. Small. 16" wide, 19" high. **\$33.95**

COPPERPLATE

Copperplate and Spencerian have gained in popularity in recent years as calligraphers expand their repertoire of letterforms. The thick & thins are caused by varying the pressure on a flexible point – a worthwhile discipline to learn. All calligraphy, as Lloyd Reynolds noted, is a series of movements involving touch.

BEGINNERS: The most popular nibs are **Brause 66EF**, **Gillott 303**, **Hiro #40**, and **Hunt 101**. Right-handers will need an oblique pen holder. All will need a bottle of **Higgins Eternal**, which is improved by the addition of 10 or 20 drops of **Gum Arabic** (184 \$12.55). **Mastering Copperplate Calligraphy** (B1109, \$12.95) by Eleanor Winters is a good book for beginners. She recommends the Gillott 404 & Gillott 303. Denys Taipale on copperplate materials: "I teach & use the following: Brause 66EF nibs – these are medium flexible nibs which provide the student with a nib not too stiff and not too flexible. I use an oblique holder... Higgins Eternal with gum arabic..."

Other teachers opt for a stiffer nib for beginners. Caroline Paget Leake notes that Hunt 101, Gillott 404, Hunt 56 are sturdy and durable making them excellent for student practice.

For Spencerian Michael Sull recommends the Hunt 101, Hunt 99 and the Gillott 404.

COPPERPLATE KITS

To make ordering easier for beginners here are several kits that include the basic materials you need to start learning copperplate calligraphy. Pointed nibs wear much quicker than broad edge nibs, so you need to purchase several.

K100-NB. Basic Copperplate Kit. Contains the basic items you need to learn copperplate. Hunt plastic oblique holder, 7 Gillott 404 nibs, 6 Gillott 303 nibs, Higgins Eternal ink, Boris Layout Pad (9"x12", 50 sheets). **\$24.05**

K100-B. Basic Kit with Book. *Mastering Copperplate Calligraphy* plus the materials in K100-NB. **\$37.75**

Nibs/Points

Nibs vary in the thickness of line they produce and in their flexibility. Experiment with a variety to find the ones you like the best.

Pointed nibs vary greatly in the design, sharpness, fineness of line, and flexibility. These assortments let you see what is available and what works best for you.

N117-1. Copperplate Nib Assortment. One each of 24 Copperplate nibs listed below. Does not include vintage nibs or music nib. **\$29.50**

N117-2. Copperplate Nib Assortment #2. The same assortment, but two each of the nibs. **\$58.25**

The nibs in the assortment are: Brause 66EF, Steno; Gillott 170, 290, 291, 303, 404, 659, 1068A, 1950; Hiro Crown, 40 (Blue pumpkin), 700; Hunt 22B, 56, 99, 100, 101, 103, 108; Mitchell Elbow; Nikko G; EF Principal; Brause Rose.

N120. EF Principal Nib. \$2.25 See page 49

N113. Nikko G Nibs. \$1.55 See page 49



N70. Brause 66EF. List \$1.40 **\$1.35** 10/\$12.50 50/\$55.00 Very flexible.

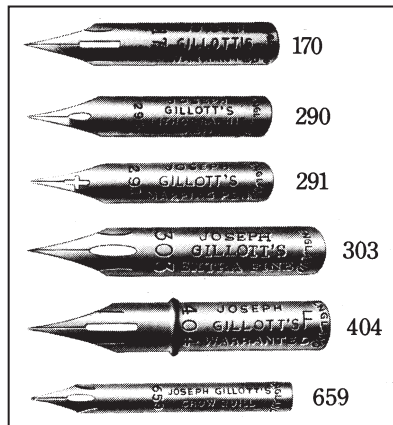

Gillott Nibs

N71. Gillott 170. List \$1.29 **\$0.90** 10/\$7.63 144/\$80.00

N73. Gillott 290. List \$1.32 **\$0.95** 10/\$7.75 144/\$85.00

N107. Gillott 291. List \$1.35 **\$0.99** 10/\$8.45 144/\$85.00

N72. Gillott 303. List \$1.19 **\$0.80** 10/\$7.10 144/\$80.00

N74. Gillott 404. List \$1.35 **\$0.99** 10/\$8.90 144/\$94.00

H75. Gillott Mapping Penholder #51. Holds crowquill nibs including Gillott 659. **\$1.99**

N75. Gillott 659. List \$1.69 **\$1.29** 10/\$11.60 144/\$85.00 (Crowquill nib)

N76. Gillott 1068A. List \$1.49 **\$1.03** 10/\$9.80 144/\$94.00

N102. Gillott 1950. List \$1.55 **\$1.08** 10/\$10.35 144/\$99.00

Please see page 36 for ordering information, including shipping charges



House Beautifully

B2470.

B2470. An Elegant Hand: The Golden Age of American Penmanship and Calligraphy by William E. Henning Edited by Paul Melzer. 2002. 320pp. 8-1/2"x11". Hardcover \$59.95. **JNB Price \$57.49**

Chronicles the history of the Golden Age of American penmanship, guiding the reader through the lives and careers of important American penmen beginning with Platt Rogers, Spencer, the Father of American Handwriting and Spencer's gifted student, George A. Gaskell, whose books and periodicals reached the hundreds of thousands of students throughout the second half of the 1800s. Illustrated with more than 400 examples, most from original specimens.

Variety Capitals

B2476.

B2476. FW Tambllyn's Home Instructor in Penmanship. F.W. Tambllyn. 2001. (Reprint of the 7th ed, 1938). 174pp. 8.5"x5.25". Spiral **\$24.95**

80 pages of instruction on basic script starting with holding the pen and positioning the paper, followed by pages of exercises, letterforms, words, and sentences to copy. Then 33 pages on Artistic Writing (Spencerian) – instruction on adding the stresses to capitals and appropriate lowercase letters. Smaller sections on Engravers Script, broad-edged alphabets, off hand flourishing, engrossing and diplomas. A great reprint. A highly recommended manual.



40

N81. Hiro #40. List \$.61 \$52 10/\$4.80 36/\$16.20 100/\$43.50. Large, blue metal with cutouts. The "blue pumpkin nib."

N90. Brause Steno Nibs. These are similar to the Blue Pumpkin (Hiro #40), but stiffer and better made. John Ebel notes that these nibs last much longer than most current nibs. List \$1.40 **\$1.25 ea.** 10/\$11.50 50/\$45.00



Crown

N82. Hiro Crown Nib. \$.50
Fine, soft nib for copperplate.
10/\$4.80 36/\$16.92 100/\$45.00



700

N83. Hiro 700. \$.45
Superfine for copperplate. Similar to Gillott 290.
10/\$4.00 20/\$7.50 100/\$34.00

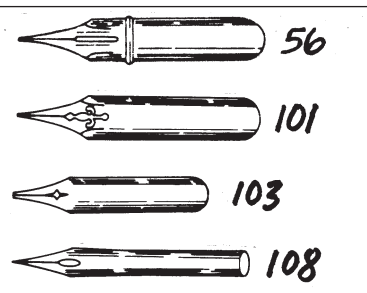

56

101

103

108

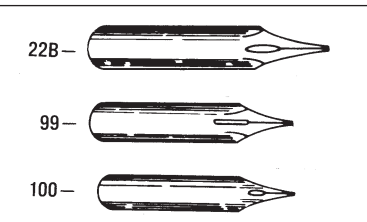

22B

99

100

N93. Hunt 22B \$.99 **N86. Hunt 56** \$.99
N88. Hunt 99 \$.99 **N89. Hunt 100** \$1.29
N77. Hunt 101 \$1.29 **N78. Hunt 103** \$1.29
N79. Hunt 108 \$1.29 **N97. Hunt 512** \$.99
N98. Hunt 513EF \$.99 **N124. Hunt 104** \$1.29
N93-V. Hunt 22 Vintage. See page 49. **\$2.25ea**

N69. Brause Rose Nib. \$2.20 **JNB \$2.00** see page 49



Mitchell Elbow Nib.

Allows you to write copperplate with a standard

holder. Fits holders H33, H30, H32. **N80. Single Nib**
\$2.15 Box of 12/\$23.22 144/\$184.32

N120. EF Principal Nib. These much anticipated nibs are now available for purchase. \$2.40.

JNB Price \$2.30each 10/\$2.10each 25/\$1.90each
50/\$1.80each 100/\$1.60each see page 49

HOLDERS

Copperplate pen holders come in two kinds: (1) an oblique pen holder with an offset that holds the nib at an angle. Right-handers use the oblique holder which makes the extreme slant of copperplate easier to write; (2) a standard straight pen holder. Left-handers use the standard holders. It is also used when an oblique holder is not available for a nib.

BEGINNERS: The different copperplate nibs are of various sizes and do not all fit in the same holders, but many fit the less expensive Hunt oblique holder.

See page 49 for Oblique holders.

See page 41, 49 & 53 for standard holders.

Copperplate Practice Pad

P01. Copperplate Grid Pad. 8.5"x11". 8 squares to the inch, Non-repro blue with slant lines for copperplate. Special smooth paper for pointed pen work. Approx 50 sheets. **\$7.95**

Mike Kecseg Ink Stick

IS28. Mike Kecseg Ink Stick. Mike uses this inexpensive ink stick for his pointed pen work. (It's not recommended for broad-edged calligraphy.) **\$10.00**

See page 44 for a selection of Japanese Ink Sticks chosen by Ewan Clayton for broad-edged calligraphy.

Oakgalls

Oakgalls. The traditional source for tannin for making oak gall ink. Even if you never have plans to make your own ink, it's neat to have a sample of the real thing to show to students.

S569. 1.5oz. \$5.00 **S567. 3oz. \$8.00**

SPENCERIAN

See page 46 & 38 for:

B2470. An Elegant Hand. JNB Price \$57.49

B2476. FW Tamblyn's Home Instructor in Penmanship. \$24.95

B368. Ames Compendium of Practical & Ornamental Penmanship by Daniel T. Ames. 1883. Reprint 1978. 60pp. 8.5"x11". Paper \$7.95

Eight pages of good instruction on writing and letterforms (Spencerian & copperplate) are followed by examples and alphabets. Flourishing (birds, feathers, etc.) is next followed by pages of 19th century ornamental lettering of all sorts. If you are interested in pointed pen writing, this book is a must buy.

B2503. At Home with Artistic Penwork by Stephen A Ziller. Set of five instructional books on pointed pen work: *Business Writing* (64pp.) *Artistic Writing* (Spencerian & Ornamental), *Card Writing*, *Engrossing Alphabets*, and *Bird & Design Flourishing* (32pp each). 8.5"x5.25". Paper \$24.95

First published in the 1940 for home instruction.



B1816. Learning to Write Spencerian Script by Michael Sull & Debra Rapp. 1993. 75pp. 6.75"x8.5". Paper \$17.50

An instructional manual for Spencerian covering equipment and tools, practice, and extensive instruction on the individual letters. This book gives the main instructional material from Volume I of Spencerian Script and Ornamental Penmanship, which is no longer available.

New in DVD!

DVD12. Learning to Write Spencerian Script by Michael Sull. DVD \$35.00

A 60 minute instructional video by the author of the comprehensive text of the same title. First he gives a brief history of the hand and then gives letter by letter instruction.



B1137-2. Volume II of Spencerian Script and Ornamental Penmanship by Michael R. Sull. 1989. 8.5"x11". Paper. Spiral bound \$29.95. **JNB Price \$19.99 through 12-31-06**

It contains the penmanship of Platt Rogers Spencer, and features over 1,000 reproductions of ornamental alphabets, correspondence writing, signature designs, novelty styles, and off-hand flourishing as penned by the great master penman.

Volume I is no longer available.

B305. Theory of the Spencerian System of Practical Penmanship in Nine Easy Lessons. (1875) 1985. 52 page instruction booklet and five 24 pp practice booklets. 8.5"x7". The set \$15.99

Facsimile of an old primer teaching the Spencerian hand in question and answer format. Originally intended for elementary school students, this method is useful for beginners of all ages.



FROM MICHAEL SULL

These three items complement Michael's instructional book and video.

B2463. Spencerian Practice Sheets. Packet of 29 printed

pages. Copybook style. Over 700 lines to practice on. Includes two pages of instruction. Also included are five blank guide sheets each of two sizes. **\$15.00**

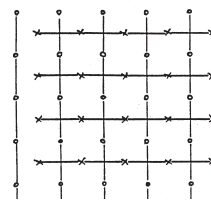

P33. Cross Drill Pad. One of the keys to mastering Spencerian is perfecting the rhythm and spacing between letters. This pad provides a series of spacing exercises. 50 sheet pad. Includes instruction. **\$7.50**

Spencerian Practice Pads. With guidelines and slant lines in light blue. There are two different pads with different x-heights so you can practice larger and smaller lettering. 8.5"x11". 3-hole punched. Approx. 50 sheets. 4 page instruction sheet. Specify Large or Small x-heights. Beginners will want to start with larger writing.

P34-LG. Large. \$7.50

P34-SM. Small. \$7.50

New in DVD! DVD23.

Off-Hand DVD: Flourishing Techniques for Ornamental Penmanship by Michael Sull. 106 Minutes. Color. **\$40.00**

Covers basic tools and materials: pen points, oblique holders, papers. Continues with preparing and using colored and gold inks including mixing a sepia ink from vermilion sumi & Higgins Eternal, using Dr. Martin's Bleedproof White & Schmincke metallic gouaches. Begins with the primary flourishing strokes. Presents the basic steps for cartouches, scrolls, border designs, quills, birds, title flourishing, accent flourishes, and creative patterns. Finishes with a selection of over 50 different historical designs by a range of master penmen. It's the closest thing to having Michael in the room teaching you!



Pliers for adjusting oblique holders S507. Small Bent Needle Nose Pliers.

Michael Sull selected these small pliers which are ideal for adjusting the flange on an oblique holder. Use them to adjust the curve of the flange for the nib you are using, to crimp the two sheets of metal in the curve a bit tighter if necessary, and to adjust the flat part of the flange to reduce the angle of the pen to the paper. They are small enough to fit in your pen pouch or traveling tool kit. **\$4.95**



Michael Sull on Spencerian Materials:

POINTS: Michael highly recommends the *Nikko G* nib. For years, *Hunt 101* was the standard tool, but not the best to start with. The *Hunt 56* with its medium flexibility is also good for those just starting.

INK: *Higgins Eternal* (108, \$3.00), the standard black ink for Spencerian, is improved by a little evaporation. By adding a little Higgins Eternal to *Bokuju Vermillion* (123, \$8.15), you can create a wonderful sepia. Use a dropper to add Higgins Eternal using a coffee stirrer to mix. *Dr. Martin's Bleedproof White* (138, \$7.40) is Michael's personal favorite white. Thin with water.

PADS: Michael Sull loves the *Clairfontaine Pads*, above. He also likes the *P31. Ampad Embassy Pad*. It is a legal pad with the usual lines rather than a pad of art paper. The surface is silky smooth – perfect for Spencerian practice. Michael's favorite for work for reproduction is the *Canson Pro-Layout Marker Pad*. See pads on page 39.

Michael recommends a cushion of blotting paper under your writing sheet. It facilitates writing. Don't write on a hard surface.

Blotting Paper. 120 lb white. These two sizes ship with books and supplies.

S261-9. 9"x12" \$.95 10/.75 20/.65

S261-11. 11"x17" \$ 1.25 10/.95 20/.85

Clairfontaine

P36. Clairefontaine Writing Pad. Triomphe. Extra white 23lb vellum finish paper. Pad of 50 sheets. 8.25x11.75. Blank. From France. **\$6.00** 2/\$5.75ea. 10/\$5.25ea

P35. Clairefontaine Pad. Staplebound, micro perforated at top. 24lb, neutral pH, crisp white paper. Ruled with pale violet lines! Pad of 80 sheets, 8.25x11.75. Ruled. From France. **\$10.00** 2/\$9.50ea 5/\$9.00ea 10/\$8.50ea.

Highly recommended by Michael Sull and Nan DeLuca for pointed pen Work. Purchase the lined pad for Spencerian practice & correspondence, the blank one for flourishing. *"Absolutely fantastic surface. You just want to write on it!"* – Michael Sull



P38. Clairfontaine GRAPH Pad.

8.5"x11.75". 80 shts **\$10.00**

P31. Ampad Embassy Pad. Legal pad with the usual lines rather than a pad of art paper. Cream. **\$2.95 ea.** 2/\$2.75 ea. 6/\$2.65 ea. 24/\$2.25 ea.

COPPERPLATE

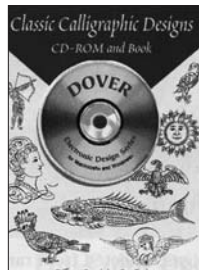

B2904. Classic Calligraphy Designs. 48pp. Book and CD-Rom. Paper **\$14.95**

New 378 off-hand flourished images of faces, creatures, birds, fish and abstract motifs. Much more than the standard quills and birds!



B1109. Mastering Copperplate Calligraphy: A Step-by-Step Manual by Eleanor Winters. 1989. 192pp. 8.25"x11". Paper **\$12.95**

A self-contained manual for serious students including beginners. Part one places copperplate in historical context. Part two begins with a glossary and detailed information on pens, paper, ink and other materials. It includes indispensable technical tips, guidelines, how to use the pen, and 99 pages of detailed instruction covering minuscule, capitals, numbers, punctuation and writing in various sizes. Part three deals with writing in color, and the design and execution of simple projects such as envelopes and small poems.

"The best manual on copperplate was certainly the one by Eleanor Winters – very complete but a bit pedantic." – James Clough

B152. Ornate Pictorial Calligraphy by E.A. Lupfer. **\$8.95**

Instructions and examples of pictorial flourishes: Quills, birds, swans, etc.

V15/DVD15. Write Like This by Buddy Blackwell. 1994. 50 minutes. Video/DVD. **\$35.00**

How-to video on Blackwell's copperplate writing. Covers materials, exercises, lowercase, uppercase, flourished alphabet. Useful. The only copperplate video available.



B145. The Zanerian Manual of Alphabets and Engrossing. 1981.

140pp. 8"x10.5".

Spiral **\$39.95**

The first 21 pages by E.A. Lupfer provide some of the best copperplate instruction available. He is a master of the hand.

Other engrossing alphabets are shown as well as many examples of engrossed pieces. Revised & reissued at intervals since it was first published as Zanerian Alphabets in 1895. Now printed on 80# gloss paper.

Also available:

B2170. George Bickham's Penmanship Made Easy. (1773) 1997. Paper **\$6.95**

B255. The Universal Penman by George Bickham. (1741). 212pp. 9"x13.75". Paper **\$21.95**

Schmincke Metallic Gouache

SG870. Gold Pearl: 14 karat gold color, yellow gold color. \$ 14.75 **JNB Price \$13.50**

SG871. Red Pearl. \$14.75 **JNB Price \$13.50**

Michael Sull on using Schmincke metallics for pointed pen work: *"They are most spectacular on darker paper."*

Black Canford Paper

PA43. Canford Black Paper. 25 sheet pack. 8.5"x11". This black paper is great for white pointed pen script. Acid-free, smooth matte black finish. Recommended by Brian Walker as ideal for pointed pen work! **\$10.00. JNB Price \$9.75** 2/\$9.50ea

PA44. Canford Black Card Stock. 10 sheet pack. 8.5"x11". \$7.25. **JNB Price \$6.95** 2/\$6.50ea





S377. Sull Leather Pen Roll-up. New with a pen point pocket with a zipper! Michael Sull designed this to carry his oblique pen holders with the nib. The four pockets are extra wide (2.25") for an oblique holder and 8.5" deep to protect the nib. The top flap gives more protection. Leather tie. Black only. **\$27.50**

S304. Dinky Dips. Used by pointed pen writers to control the depth the nib is dipped into the ink. 4 small, clear vials with lids in a base. **\$2.95**

S305. Dinky Dip Refills. 8 vials & lids. **\$2.95**

OBLIQUE HOLDERS

H23. Hunt Oblique Holder. Plastic hourglass shape with offset for nib. **\$1.89**

For Gillott 404, 303, 290, 170, 1068A, 1950, and Hunt 108, 101. Brause 66EF and Hiro 40 can be used, but they better suited to specially made holders listed below.

H59. Del Tysdal Holder. Zanerian style rosewood holder. Metal oblique arm holds nib. 8.25". **\$35.00**

H51. Century Oblique Holder. These gorgeous turned wood pen holders have a metal flange. They are made to hold the Gillott 303 and Hunt 101 (and similar sized nibs). They can be adjusted with needle nosed pliers to fit other nibs. **\$19.95**

H52. 5/8" Century Oblique Holder. Joe Vitolo has modified the design of the Century Oblique Holder. The thicker holder may reduce hand fatigue. **\$19.95**

H48. Ziller Oblique Holder. These less expensive oblique holders are pre-adjusted for our most popular pointed nibs. Metal flange, grey plastic handle. Specify Gillott 303, Gillott 404, Brause 66EF, Hunt 101, Nikko G, EF Principal. *This holder can be adjusted for virtually any nib. Please let us know the nib you use & we will pick the closest holder.* **\$11.25**

H75. Crowquill Penholder #51. Holds crowquill nibs including Gillott 659. **\$1.99 (Straight)**

H50. Blackwell Oblique Holder. A remarkably simple design that holds most pen points for Spencerian and Copperplate. Finely crafted wood holder with a sturdy brass oblique arm. Designed to hold the nib at a less steep slant angle for ease of upstrokes. Also available with a plastic holder. **\$35.00 (Works with most all nibs except crowquills and the very largest vintage nibs)**

H61. Plastic Handle Blackwell Oblique Holder. Black plastic hour glass holder with the same brass flange for holding the nibs. The brass work is not as finely finished, but is just as functional. **\$25.00**

EF Principal Nib

After a year in development, you can now purchase a modern nib that is equal to the best of the vintage nibs. Brian Walker, a respected pointed pen enthusiast, has

worked with a pen manufacturer to duplicate the quality and performance of the legendary Gillott No 1 Principality. The new nib has received rave reviews for both copperplate and Spencerian. It's flexible and responsive, gives fine hairlines, but is smooth writing & catches the paper less.

N120. EF Principal Nib. These much anticipated nibs are now available for purchase. \$2.40. **JNB Price \$2.25 each 10/\$2.00 each 25/\$1.75each 50/\$1.65each 100/\$1.50each**

Other Pointed Nibs

N113. Nikko G Nibs. These new nibs from Japan are hand cut, extremely smooth and long lasting. They are chrome plated and have a medium flex. Great for Spencerian. Smooth writing with no burrs or scratchiness. Highly recommended by Michael Sull. Extremely popular with pointed pen men and women! **\$1.55 3/\$1.45ea 10/\$1.40ea 50/\$1.35ea 144/\$1.20ea**

N69. Brause Rose Nib. The Brause Pen Company worked to manufacture a nib with the qualities of vintage nibs. This flexible nib was a John DeCollibus favorite at IAMPETH. **\$2.20 JNB\$2.00**

N93-V. Hunt 22 Vintage. "Extra Fine." With the exception of Nikko G, EF Principal and Brause Rose Nibs, they just don't make pointed nibs like they used to. You will find that the Vintage Hunt 22's do write better than most modern nibs and you should find very few defective ones. Vintage are brass colored, the current ones grey colored. **\$2.30ea 10/\$2.10ea 50/\$1.80ea 100/\$1.60ea**



PENTEL COLOR BRUSH



Fran Sloan illustrates the variety of weights and sizes of lettering that can be done with the Pentel Color Brush. Shown 30% actual size.

FP57. Pentel Color Brush. Much sought after. For brush lettering. Specify color: Light Green, Turquoise, Olive Green, Pale Orange, Steel Blue, Gray, Orange, Sepia, Purple, Black, Red, Blue, Green, Yellow, Brown, Orange, Pink, Sky Blue. **\$8.50**

FP58. Pentel Refills. Specify color. **\$3.75.**

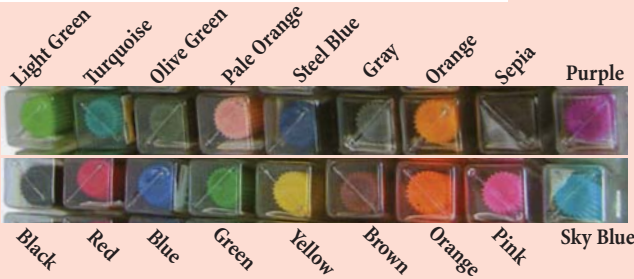

Metallic Color Brushes

M36. Metallic Color Brushes. Gold, Silver, Bronze; Metallic Blue, Red Green, Light Green, Violet. Specify Color **\$7.65 each.**
M36-GS: Gold & Silver Pentel Color Brush. \$15.00



FP93. Pentel Waterbrush. \$6.49ea

New Same excellent nylon brush as the Pentel Colorbrush. Large barrel. Fill barrel with water or waterbase media: ink, watercolor or gouaches. Designed so that it won't roll off your table. Specify size: Mini (13mm brush, small barrel) Fine (10mm), Medium (13mm, medium barrel) or Broad (18mm). 2/\$6.25ea. 3/\$6.00ea.

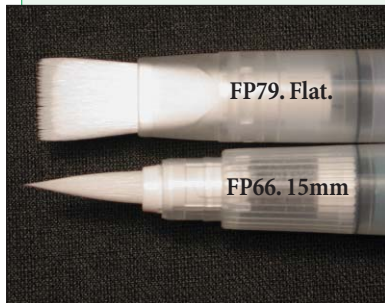
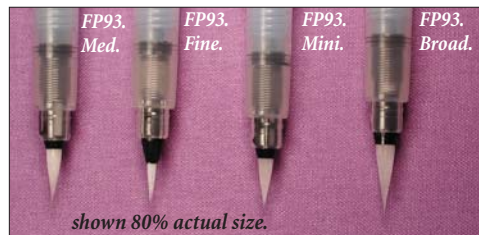

NIJI WATERBRUSHES

We often complain that they don't make things like they used to. Too often an item that was great is no longer as fine a tool or material. Or manufacturers simply stop making a good product. However, sometimes new tools come along. Niji waterbrushes are an example. They are basically a marker with a high quality brush that you can fill with your choice of water media.

FP79. Flat Waterbrush. 12mm. \$10.30
FP64. Pointed Waterbrush. 9mm. \$7.50
FP66. Pointed Waterbrush. 15mm. \$8.85

MARKERS

Markers are fun and they are easy to use! They are now reasonably light-fast and waterproof!

CHISEL EDGE MARKERS

M02. Marvy Calligraphy Markers. Similar to the Elegant Writers but a little less expensive. The 5mm is particularly good – a wet ink flow and nicely thin lines. Black. Specify size: 2.0, 3.5, 5.0mm. Boxes of 12 only. 12/**\$18.00** Special order item

M06. Zig Waterproof Marker. Pigmented waterproof ink. 2.0 & 5.0mm on each pen. Now called

Memory System Calligraphy Marker. \$3.00 each.

Specify Color:
10 Black 40 Green
20 Red 80 Violet
30 Blue

M04. Staedtler Duo Calligraphy Marker. 2.0 & 3.5mm on each pen. Waterproof. Specify: Black, Red, Blue, Deep Violet. \$2.85ea.

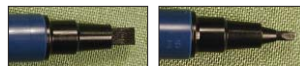

Index on page 34

FOUNTAIN PENS

Shown actual size.



PILOT PARALLEL PENS w/ Parallel Plate Nibs.
Hard to find, much sought after, these pens are not widely distributed in the US.

Extremely smooth writing from this pen, offering crisp edges and sharp hairlines. Nib point consists of two parallel metal plates and allows for lettering in two sizes. Use the .5mm edge for sharp, monoline writing or use the broad edge for calligraphic writing. You can also produce color-blended letters by touching ink from one pen to a second pen loaded with another color. Available in four sizes, includes one red and one black cartridge and a bladder/converter.

FP67-1.5. 1.5mm. FP67-3.8. 3.8mm.
FP67-2.4. 2.4mm. FP67-6.0. 6.0mm.

\$17.95 each 2 or more \$16.95 4 or more \$15.95

FP67-S. Set of 4 Pens (each with 2 cartridges) and a pack of 12 cartridges (one each of 12 colors). **\$.68.00**

FP67-12. Assorted Pack of 12 Color Cartridge Refill (one each of the colors below).

\$4.95 2/\$4.75 6/\$4.50

FP67-6. Pack of 6 Color Cartridges. All one color. Specify: Black,

Blue-Black, Sepia, Violet, Blue, Turquoise, Green, Light Green, Yellow, Orange, Red, Pink. **\$.2.95**



S382. Monoject 412. Use this plastic syringe to refill Parallel Pen cartridges with bottle ink or for filling dinky dips. Many craft and calligraphy uses. **\$1.50** 2-4 /1.25 ea. 5/\$1.15 ea.

LAMY CALLIGRAPHY PEN

These calligraphy fountain pens from Germany have more class than the rest. Your calligraphy friends won't expect to see your calligraphic letters flowing from these. And they are a joy to use. They are designed for both function and form. The writing end has two facets that fit your fingers. All have a window to check for low ink level. The ink flows well.

The clear one is my favorite with its see-through design



and chrome accents. I love having a modern Bauhaus design to create renaissance and medieval letters! The satin gray is more formal. The black long-staff pen comes with red accents.

Lamy Calligraphy Pen. Specify Nib size: 1.1mm, 1.5mm. Specify Barrel Style:

FP85. Satin Gray. \$45.00 each
FP85-CON. Satin Gray converter. \$4.95
FP86. Clear. \$35.00 each
FP87. Black Long-Staff. \$30.00 each

FP89. Lamy Converter. So you can use bottle ink. For clear & long-staff. **\$4.95**

FP88. Lamy Cartridges. Pack of 5 (long). Black. **\$.2.95**

Lamy Calligraphy Nib. Shown actual size.



Lamy Calligraphy Pens.

ROSE TENDRESSE /61	JAUNE BOUTON D'OR /52	VERT PRE /31	BLEU AZUR /72
ROSE CYCLAMEN /68	AMBRE DE BIRMANIE /41	LIERRE SAUVAGE /37	BLEU PERVENCHE /71
ROUGE OPERA /66	ORANGE INDIEN /37	VERT RESEDA /38	ECLAT DE SAPHIR /36
BOUQUET D'ANTAN /64	ROUGE CAROUBIER /22	DIABOLO MENTHE /23	BLEU NUIT /78
CAFE DES ILES /46	POUSSIERE DE LUNE /48	VERT OLIVE /38	BLEU MYOSOTIS /73
CACAO DU BRÉSIL /45	VIOLETTE PENSÉE /77	LIE DE THE /64	GRIS NUAGE /69
TERRE DE FEU /47			PERLE NOIRE /67

New **I93. Herbin Inks.** Fountain pen inks that originate from Paris, 1700. Non toxic and pH neutral. Water based, flows smoothly and is fast drying. **\$.9.00**

26 colors: Rose Tendresse (*Light Fuchsia*), Rose Cyclamen (*Intense Fuchsia*), Rouge Opéra (*Burgundy*), Bouquet d'Antan (*Light Wine Red*), Café des Îles (*Chocolate Brown*), Cacao du Brésil (*Sepia*), Terre de Feu (*Burnt Sienna*), Jaune Bouton d'Or (*Buttercup Yellow*), Ambre de Birmanie (*Transparent Yellow Ochre*), Orange Indien (*Orange*), Rouge Caroubier (*Red*), Poussière de Lune (*Brownish Purple*), Violette Pensée (*Bluish Purple*), Vert Pré (*Lime Green*), Lierre Sauvage (*Dark Leaf Green*), Vert Réséda (*Bluish Green*), Diabolo Menthe (*Aqua Blue*), Vert Olive (*Olive Green*), Lie de Thé (*Brown*), Bleu Azur (*Sky Blue*), Bleu Pervenche (*Turquoise*), Éclat de Saphir (*Ultramarine*), Bleu Nuit (*Navy*), Bleu Myosotis (*Forget-me-not Blue*), Gris Nuage (*Steel Gray*), Perle Noire (*Black*).



Quills

Quills are very light, very flexible, and deliver a wide variety of media easily – thick gesso, creamy gouache or thin ink.

N24. Uncut Cured Goose Quill. \$2.50

N26. Goose Quills. Uncut. Uncured. **\$1.25** each. 5/\$1.00each

N44. Packet of 5 Quills. Cured and cut to a point for writing. Mixture of goose and turkey, white, brown, black and barred. Feathers decoratively trimmed, some to allow only a bit of the barbs, others with the full feather. Some with an oval of barbs at the end



of the quill. Great for colonial day at home or school, or as a decorative accessory for your inkwell collection. **\$14.00/pack, 6/\$12.00ea.**

N29. Goose Quills. Seconds. Uncut, Uncured. The barbs of these feathers are damaged. **Pkt of 5/\$3.00,** pkt of 10/\$5.50

N42. Turkey Quills. Uncut, cured **\$2.00** each

N43. Turkey Quills. Uncut, uncured **\$1.25** each. 5/\$1.00each

S398



S397

Decorative green glass jars. Wide mouth. Includes cork. Approx 3" tall. with the cork

S397. Octagonal Green Glass Jar. \$2.55

S398. Square Green Glass Jar. \$2.55

6/\$2.10ea 12/\$1.95ea. Same or assorted.

Octagonal 40ml, Square 25ml. (oz=30ml.)



S429. Square ABC Inkwell.

A porcelain reproduction of a classic French 1920's glass school inkwell. Pen rests around the neck, loose stopper with logo, elegant script alphabet in red wrapped around base. Beautifully gift boxed. **\$11.99**



rotring

Rotring Calligraphy Pen. A sleek, longstaffed, smooth writing and remarkably light in weight fountain pen. The black ink cartridges are a dense, matte black.



FP38. Rotring Calligraphy Pen Set.

3 pens (1.1, 1.5, 1.9mm unless you specify otherwise), sharpening stone, box of 6 black cartridges in a metal case. \$75.50. **JNB \$72.50**

FP36. Rotring Calligraphy Pen.

Pen and five cartridges. Specify size: 1.1, 1.5, 1.9, 2.3mm. \$25.99. **JNB Price \$24.50**

FP37. Rotring Converter. A piston fill converter to allow you to use bottled ink. **\$7.90**

FP39. Rotring Cartridges. Box of 6. Black. **\$3.85**

Please see page 36 for ordering information including shipping charges



FP90. Manuscript Calligrapher's Deluxe Set.

FP90. Manuscript Calligrapher's Deluxe Set.

Black barrel, Six interchangeable gilt broad-edge nibs: F, M, B, 2B, 3B, 4B. Four black cartridges.

Smooth writing, good thicks and thins. Great for beginners, quick work, and envelope jobs. F=.85mm, M=1.1mm, B=1.35mm, B2=1.6mm, B3=2.2mm, B4=2.8mm. *Specify Right or Left Hand.* **\$20.99**

FP91. Manuscript Cartridge 12 pack. Black. **\$4.50**

FP92. Converter, barrel, & cap for Manuscript. **\$5.95**



FP40.

Sheaffer Calligraphy

FP40. Sheaffer No-Nonsense Calligraphy Set. Boxed set. Barrel, 3 nibs (FMB), 4 cartridges. Right hand only. **\$10.95**

FP42. Sheaffer Cartridges. Box of 5. Black. **\$5.00**

FP41. Sheaffer Replacement Nib. Specify F, M, B. **\$2.25**

BURNISHERS



S459. Hematite Lipstick Burnisher.

For burnishing raised gold to a mirror finish. Peter Thornton has worked closely with a German craftsman to produce this burnisher to his design and specifications. It is a lipstick shape with a slightly convex surface and rounded edges. The tip is the prized, high quality soft hematite

that is so sought after for burnishers. The tip is glued to an agate base. Approx 6". **\$95.00**

S537. Jewelers Rouge. Use this jewelers polishing material on your leather strap as recommended by Peter Thornton when gilding with a hematite burnisher. **\$6.00**

S194. Agate Dogtooth Burnisher. This small burnisher is crafted for us in Nepal. It's great for a variety of burnishing needs. *Hope to have available again Spring 2007.* **\$32.00**



M08. Pilot G Tech Pens.

Metal tip. Smooth writing, don't skip. Recommended by Sheila Waters and others. Not widely available in the USA.

Non-waterproof.

M08.G-Tech 3 Pen. 0.15mm (slightly smaller than 005 Pigma Micron). Black. **\$3.25**

M08. G-Tech 4 Pen. 0.2mm. (same as 005 Pigma Micron) Black. **\$3.25**

M08-S5. G-Tech 4 Set of 5. 4 colors plus black. **\$15.95**

M08-S10. G-Tech 4 Set of 10. 9 colors plus black. **\$29.95**

N21. Suede Pen. Made of metal and ultra suede. They will hold and deliver ink to vertical surfaces without danger of spills.

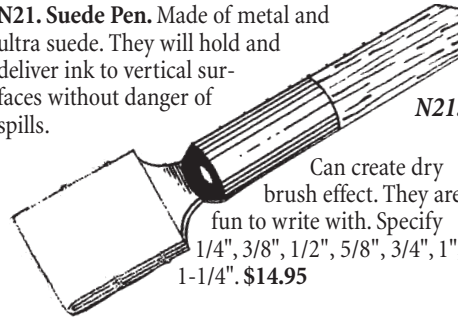

N21.

Can create dry brush effect. They are fun to write with. Specify 1/4", 3/8", 1/2", 5/8", 3/4", 1", 1-1/4". **\$14.95**

HOLDERS



H60.

H60. Fine Wood Pen Holders. These beautiful, hand turned, exotic wood holders range from 6" to 7.25" and come in a variety of woods. Each is a unique work of art as well as a functional tool. You can specify short or long and red, brown, black wood colors and we will try to match your wants as close as is possible. **\$19.99**

H62. Mahogany Pen Holder. Straight wood pen holder. \$2.50
JNB Price **\$2.29** Not pictured.

*See page 41 & 49 for holders
See page 49 for Oblique holders*

PADS

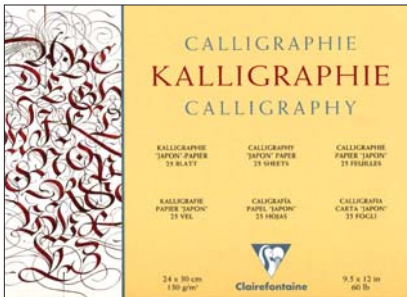

Papier Japon. Japanese-style paper from the Netherlands. Satin-like texture for calligraphy with India ink, nibs, brushes. 25 sheets 60 lb. white paper. P26. 9.5x12" **\$22.00** P27. 12x16" **\$31.00.**

PORTABLE LIGHT TABLE

S247. Wordcrafters Portable Light Table. 16"x20" frosted plexi top locks shut for transport, swings up to 8 different slant positions. Hardwood case. A sturdy & comfortable handle makes transport easy. An 18" florescent fixture provides illumination. There is space in the box for calligraphic tools. Versatile enough to use at home & to transport to workshops or to take on trips. A time-tested design developed by a calligrapher and a woodworker. **\$135.00**



The Wordcrafters Portable Light Table combines the best features of a light box, an adjustable easel, and the traditional slanted writing box.



INK



I43. Best Bottle Sumi. This popular new (to western calligraphers) Japanese sumi ink is good both for beginners and for professional work. Smooth, rich black. Hard to find. 6.66 oz bottle. **\$15.85**



I70. Moon Palace Sumi. While the packaging is a bit different, this is the highly sought after and highly recommended Japanese Sumi Ink. For both broad edge and pointed pen work. Works in Parallel Pens. Dries waterproof. 6.5oz, 180ml. **JNB Price \$10.95**



Dr. Martin's Iridescent Calligraphy Colors

These are great. These colors flow out of a broad edge pen like ink. 1oz glass bottles with dropper top. Colors can be mixed. Truly waterproof when dry. The manufacturer says they are lightfast. The set of 12 colors comes with a 12-pan mixing palette, 12-bottle holder, & a small cup for water. For individual colors, specify color. The sets are one of each color. *Copperplate Gold* is the most popular color. **I16 Iridescent Calligraphy Colors. \$5.40 each**

I16-S12. Set of 12. \$58.95. JNB Price \$57.95

I16-JADE	Jade	I16-BKSP	Black Sparkle
I16-ORCH	Orchid	I16-BLUE	Blue
I16-SALM	Salmon	I16-CGLD	Copperplate Gold
I16-SIL	Silver	I16-DBLU	Deep Blue
I16-VIL	Violet	I16-GRN	Green
I16-WHI	White	I16-YEL	Yellow

I16-S12-M. Set of 12 Metallic colors.

List \$58.95. **JNB Price \$57.95**

I16-AMET	Amethyst	I16-METG	Metallic Green
I16-BRASS	Brass	I16-MIST	Misty Blue
I16-BRON	Bronze	I16-NICK	Nickel
I16-COPP	Copper	I16-ROSE	Rose Flame
I16-CRYS	Crystal Mint	I16-SAFR	Saffron Yellow
I16-FROS	Frosted Peach	I16-SEQU	Sequin Blue

McCaffrey's



Ivory	Red
Indigo Blue	Red Violet
Green	Black
Brown	Glossy Black

I37. McCaffrey's Penman's Ink. This oak gall ink was developed with the help of leading penmen of today to provide an ink similar to that used during America's golden age of Ornamental Penmanship in the 19th and 20th centuries. With a newly opened bottle, the ink writes brown, but turns a dense black. Good for fine hairlines. See website for colors and ivory McCaffrey's (colors and ivory are not oak gall inks).

I37. 1oz jar. **\$6.00** **I37-4.** 4oz glass bottle. **\$19.50**

I37-XXX. McCaffrey's Colors (not oak gall)

BLU. Indigo Blue \$8.00	RVIO. Red Violet \$8.00
PUR. Purple \$8.00	GRN. Green \$8.00
RED. Red \$8.00	WHT. Ivory White \$6.00
GLOS. Glossy Black \$6.00	BRN. Brown \$8.00



Red	Green
Brown	Purple
Turquoise	Black

I04. Pelikan 4001. A superior dye ink primarily for fountain pen use. Will flow dependably. If ink has dried in pen, soak the pen in plain water. Non-waterproof. 2oz glass bottle. Specify color: Red, Brown, Turquoise, Green, Purple, Black. **\$7.25**

I23. Bokuju Vermilion. A dense, opaque waterproof color that is easy to write with. In an orange plastic bottle. 2oz. **\$8.15**



Scarlet	Red
Brown	Blue
Green	Black

I07. Calli. Pigmented, waterproof ink for fountain pen and dip pen use. Colors are brighter and more opaque than dye ink such as *Pelikan 4001*, but less so than gouache. Specify color. 1oz. **\$4.75**

I07-S6. Calli. One of each color. **\$27.95**



I55. True Walnut Ink. Made from the husks of American Black Walnut. Finest hairlines, warm rich color. 1oz. **\$8.00**

Walnut (Color) Ink. A rich sepia ink. Thin with water to create a wash. For brush or dip pen. Already liquid. Non-waterproof (but not suitable for fountain pens).

I53-2.5. 2.5oz. **\$6.00** **I53-10.** 10oz. **\$16.25**

S449. Walnut (Color) Ink Crystals. Add distilled water, wait for 25-35 min. & this powder produces a warm, rich walnut-colored ink. The ink is lightfast, flows well and is highly recommended by many master scribes. **1 oz. \$2.95** **2 oz. \$4.25** or **4oz. \$7.25**



Green	Brown
Blue	Black
Red	

I59-XXX. Winsor & Newton Calligraphy Inks. If you are looking for colored calligraphy inks for your fountain pens, try these non clogging, pigmented inks both for dip and fountain pen use. Unlike dye based fountain pen inks, these are more opaque, more brilliant and more lightfast. 30ml bottle. *Specify Color: Black, Crimson, Dark Blue, Green, Sepia.* **\$4.95 each.** **I59-S5.** Set of 5. **\$19.50**

See page 34 for index



Ziller



-  North Wind White
-  Sunflower Yellow
-  Prairie Fire Orange
-  Cardinal Red
-  Sweet Grass Green
-  Midnight Blue
-  Wild Viola Violet
-  Buffalo Brown
-  Soot Black
-  Glossy Black

Pigmented, lightfast, water-proof (acrylic) for dip pens (pointed & broadedge) & brushes. Stir well before using. Dip nib or brush in ink, wipe off excess ink on jar edge or shake pen. Thin ink with distilled water. Intermixable to create other colors. Clean up pen with water & a little ammonia. New glass jars with metal lid.

- I28-GLOS. Glossy Black. \$5.45
- I28-SOOT. Soot Black (matte). \$6.35
- I28-WHI. North Wind White. \$3.75
- I28-RED. Cardinal Red. \$7.95
- I28-YEL. Sunflower Yellow. \$4.35
- I28-BLU. Midnight Blue. \$7.95
- I28-ORN. Prairie Fire Orange. \$4.20
- I28-GRN. Sweet Grass Green. \$7.65
- I28-VIO. Wild Viola Violet. \$7.55
- I28-BRN. Buffalo Brown. \$5.45

GOLD / SILVER

INK

I27-GLD. 18 Carat Gold Spectralite. Popular for pointed pen work. 1oz plastic dropper bottle. Acrylic. Waterproof when dry. Recommended by Mike Kecseg & others for pointed pen work. One of the most popular golds in a poll taken by Cyberscribes. \$5.45

I16-CGLD. Dr. Martin's Iridescent Calligraphy Ink: Copperplate Gold. \$5.40 *see page 54*



I94. Schmincke TroCol Metallic Powders. Finely ground dry metal powders with a gum Arabic binder. Can be added to projects such as pastepaper to give a bit of sparkle or luster. Add water and use alone for a brilliant metallic color. These are metal

(bronze) powders so they are not archival. *Specify color:* Rich Gold, rich pale gold, pale gold, silver, copper. 20ml jar. \$8.95



I56. Winsor & Newton Gold Ink. Both Mike Kecseg and Valerie Weilmunster recommended this gold for decorating letters at their classes at IAMPETH. 1oz glass bottle. \$7.80

GOUACHE / WATERCOLOR

Holbein Brilliant Gouache. 15 ml. This new gouache provides a sparkly effect. Works well in brush and pointed pen. Not recommended for broad-edged pens; use Holbein Pearl Gouaches.



Brilliant Gold



Brilliant Silver

HG644. Brilliant Gold. \$15.70
HG646. Brilliant Silver. \$15.70

Holbein Designer Gouache. These metallic gouaches are great for both broad-edge, pointed pen, and brush work. They are finely ground mica based metallics.



Pearl White



Pearl Copper



Pearl Gold

HG640. Pearl White. \$12.25
HG641. Pearl Gold. \$12.25
HG642. Pearl Copper. \$12.25
For Metallic Silver gouache, add a touch of black watercolor or gouache to the Pearl White. Add more black until you get the shade of silver (gray) you need. For metallic pastel gouache, add the appropriate color of watercolor or gouache to the Pearl White.



SG893-F. Full Pan Schmincke Pan Watercolor. Another version of our most popular gold. This will arrive solid in a plastic pan. Add water with a brush and work up a quantity to write with. It seems to have more sparkle than gouache. The color is similar to Schmincke Gold Pearl Gouache (a yellow gold). **Full Pan**

SG893-F. Gold Pan Watercolor \$12.25 JNB \$11.50
SG894-F. Silver Pan Watercolor \$12.25 JNB \$11.50

SG870. Schmincke Gold Pearl Gouache. 14 karat gold color, yellow gold color. \$14.75 JNB \$13.50

See page 44 & 56 for more gouache.



Pan Gold. Metallic Watercolor in 2.75" ceramic pans. Recommended by Carol Pallesen for its

very fine grind. May need some Gum Arabic as a binder.

141-58. Pale Gold. \$12.90
141-59. Rich Gold. \$12.90



M37. Krylon Leafing Pens. Unlike regular metallic markers, these chisel tip pens lay down metallic color with a mirror finish. It looks like shiny metal leaf. According the manufacturer they are acid

free/archival. Works on paper, glass, metal, ceramic, etc. Specify: Gold, Silver, Copper. \$8.65 2/\$8.50ea 3/\$8.25ea

For black ink, see page 42
For ink sticks and stones,
see page 44 & 60

To receive our free e-mail newsletter, send a request to enews@JohnNealBooks.com

GOUACHE



Schmincke

This difficult-to-find German gouache is highly recommended by Michael Sull for its brightness, smooth flow and lightfastness. Because mica instead of metal particles is used, the metallics will not darken over time and because the mica can be more finely ground, it flows through a pen much better. Also recommended by Katrina Berry and others. Schmincke gold pearl is our bestselling gold gouache. 20 ml tubes.

When using a fresh tube, squeeze out the clear stuff (glycerin) until you get dense pigment. This glycerin helps keep the gouache from drying in the tube but will keep your work from drying as well. This gouache reconstitutes easily and quickly if it has dried in your pen or on your palette.

SG27-S13. Schmincke Calligraphy Gouache Set. A 13 color set of gouache especially developed for calligraphers. The colors are brilliant, mainly opaque and of an especially fine consistency. The set, designed for mixing, includes a cool and warm version each of yellow, red & blue. Opaque white, lemon yellow, cadmium yellow light, vermillion red, madder red, ultramarine deep blue, Paris blue, chromium oxide green, burnt sienna, jet black, ivory black, gold pearl, red pearl. 20ml tubes. \$165. **JNB Sale \$145.00 through 02-28-07**

INDIVIDUAL TUBES: \$14.95 **JNB Price \$13.50** each



Colors, Blacks, White
SG101. Opaque white
SG210. Lemon yellow
SG211. Cadmium yellow lt
SG320. Vermillion red
SG321. Madder red
SG430. Ultramarine deep blue
SG431. Paris blue

SG540. Chrom oxide green
SG650. Burnt sienna
SG761. Jet black
SG760. Ivory black
Metallics
SG870. Gold pearl
SG871. Red pearl

Holbein



HG800-5. Holbein Designer's Gouache Primary Set. What a wonderful idea. You get five primary colors at a fraction of the cost of larger tubes. Permanent White, Ivory Black, Peacock Blue, Lemon Yellow, Carmine. 5ml tubes. List \$20.00 **JNB Price \$16.00**

SUMINAGASHI SET



S150. Boku Undo Marbling Set. Six tubes of color suitable for suminagashi marbling. All you need is a shallow container larger than the item you plan to marble, a pointed brush, and plain water to marble sheets of paper and envelopes. Instructions included. Six 12ml (.42oz) bottles of color. **\$15.99**



If you are new to gouache, you might want to start with **Venetian Red** or **Oxide of Chromium** (a shade of green). Ewan Clayton recommends these two colors because the pigments in these colors flow especially well through the pen.

Hazel Dolby's Winsor and Newton Double Primary Set

☞ **WARM RED** (OrangeRed). EITHER **WNG102. Cadmium Red Pale, \$20.20** OR **WNG249. Flame Red, \$8.35**

☞ **COOL RED** (Bluish Red). **WNG004. Alizrn Crimson, \$8.35**

☞ **WARM BLUE** (Viot Blue). **WNG660. Ultramarine, \$8.35**

☞ **COOL BLUE** (Greenish Blue). EITHER **WNG137. Cerulean Blue \$20.20** OR **WNG467. Peacock Blue, \$10.25**

☞ **WARM YELLOW** (OrangeYellow). EITHER **WNG118. Cad. Yellow Pale, \$20.20** OR **WNG627. Spctrm Yellow, \$8.35**

☞ **COOL YELLOW** (Grnsh Ylw). **WNG345. Lemon Yellow, \$8.35**

WNGPDP-S. Permanent Double Primary Set. With the most permanent & more expensive pigments. 6 Colors & white. **\$91.00**

WNGDP-S. Double Primary Set. With the less permanent (lightfast) pigments. 6 Colors plus white. **\$59.00**

Winsor Newton Gouache. 14ml tubes. Gouache is priced by the color (pigment). Some colors may be special order and will take about a week to ship.

Series 1 \$8.35 Series 2 \$10.25 Series 3 \$13.70 Series 4 \$20.20
 AA-Extremely Permanent A-Permanent
 B-Moderately Durable C-Fugitive.

Code Color Series Permanence

WNG004- Alizarin Crimson 1 B
 WNG006- Alizarin Rose 1 B
 WNG022- Azure Blue 2 A
 WNG028- Bengal Rose 2 C
 WNG046- Brilliant Green 1 A
 WNG050- Brilliant Red 1 B
 WNG052- Brilliant Violet 1 B
 WNG055- Brilliant Yellow 3 A
 WNG074- Burnt Sienna 1 AA
 WNG076- Burnt Umber 1 AA
 WNG086- Cad Lemon Yellow 4 A
 WNG089- Cadmium Orange 4 A
 WNG092- Gouache Cad Primrose 4
 WNG097- Cad Red Pale 4 A
 WNG102- Cadmium Red Dp 4 A
 WNG111- Cad Yellow Dp 4 A
 WNG118- Cad Yellow Pale 4 A
 WNG137- Cerulean Blue 4 AA
 WNG148- Chinese Orange 2
 WNG178- Cobalt Blue 4 AA
 WNG181- Cobalt Pale Hue 1 A
 WNG211- Cyprus Green 2 A
 WNG249- Flame Red 1 A
 WNG257- Flesh Tint 1 B
 WNG270- Forest Green 2 A
 WNG271- Geranium 2 C
WNG283- Gold 3 A
 WNG285- Gold Ochre 1 A
 WNG287- Golden Yellow 3 A
 WNG297- Grenadine 2 A
 WNG309- Havannah Lake 2 B
 WNG322- Indigo 1 A
 WNG327- Intense Blue 2 A
 WNG331- Ivory Black 1 AA
 WNG335- Jet Black 1 A
 WNG337- Lamp Black 1 AA
 WNG345- Lemon Yellow 1 A
 WNG360- Light Purple 2 B
 WNG369- Linden Green 2 B
 WNG378- Madder Carmine 3 B
 WNG380- Magenta 2 C
 WNG384- Marigold Yellow 1 A
 WNG414- Mistletoe Green 2 A
 WNG422- Naples Yellow 1 A
 WNG436- Neutral Grey #3 1 A

Code Color Series Permanence

WNG447- Olive Green 2 A
 WNG452- Orange Lake Deep 1 A
 WNG453- Orange Lake Light 1 B
 WNG459- Oxide of Chromium 2 AA
 WNG463- Parma Violet 2 C
 WNG467- Peacock Blue 2 A
 WNG471- Periwinkle Blue 2 B
 WNG508- Perm Yellow Deep 1 A
 WNG482- Perm Green Deep 2 B
 WNG483- Perm Green Light 2 B
 WNG484- Perm Green Medium 2 B
 WNG512- Perm White 1 A
 WNG514- Phthalo Blue 1 A
 WNG523- Primary Blue 1 A
 WNG524- Primary Red 1 B
 WNG527- Primary Yellow 1 A
 WNG538- Prussian Blue 1 A
 WNG544- Purple Lake 2 B
 WNG552- Raw Sienna 1 AA
 WNG554- Raw Umber 1 AA
 WNG564- Red Ochre 1 A
 WNG574- Rose Carthame 1 C
 WNG591- Rose Malmaison 1 C
 WNG593- Rose Tyrien 2 C
 WNG599- Sap Green 2 A
 WNG603- Scarlet Lake 2 A
 WNG609- Sepia 1 AA
WNG617- Silver 3 A
 WNG621- Sky Blue 1 A
 WNG623- Spectrum Red 1 A
 WNG625- Spectrum Violet 1 C
 WNG627- Spectrum Yellow 1 A
 WNG656- Turquoise Blue 2 A
 WNG660- Ultramarine 1 A
 WNG668- Ultramarine Dp 1 A
 WNG676- Vandyke Brown 1 AA
 WNG678- Venetian Red 1 A
 WNG692- Viridian 3 AA
 WNG694- Viridian Lake 2 A
 WNG706- Winsor Blue 3 A
 WNG708- Winsor Emerald 3 A
 WNG720- Winsor Green 3 A
 WNG744- Yellow Ochre 1 AA
 WNG748- Zinc White 1 A

NEW BOOKS FROM EUROPE

These are expected in January 2007. Some may arrive earlier, some later. You are encouraged to reserve a copy of these titles now. You can send a check now (add \$4.00 for shipping per book) and the check won't be cashed until just before the book ships. (Your check is preferred over a debit card.) You may also pay by credit card. Your card won't be charged until just before the book ships. If you prefer, we can also send you an email notice when each of the books is available.

Denise Lach

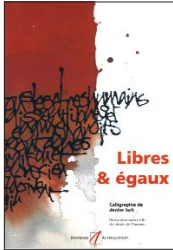

B2915. Libres & égaux. 2001. 8"x12". 128pp. Paper \$55.00. Introductory price **\$52.00** through 1-31-07

New Calligrapher Denise Lach provides over 50 calligraphic compositions to accompany parts of the UN Declaration of Universal Human Rights. Her varied layouts and refined color palette are worthy of study. Highly recommended by Peter Thornton.

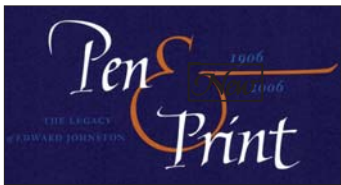

B2916. Pen & Print 1906-2006: The Legacy of Edward Johnston. 2006. 96pp. 9.5"x11". **\$55.00**

New This full color catalog reproduces 60 pieces including work by Denis Brown, Donald Jackson, Stan Knight, Susan Hufton, Mary Noble, Timothy Noad, John Woodcock, Gerald Fleuss, Sam Sommerville, Ann Hechle, and Ann Camp. The pieces – on paper, vellum, fabric, glass and stone – range from traditional Royal letters patent to abstract compositions. Essays: Timothy Noad on Illuminating, John Nash on Brush Lettering, Michael Renton on Wood Engraving, Careth Colgan on Inscriptions, Susan Hufton on Writing, Charmain Mocatta on Lettering on Glass.

Letter Arts Review

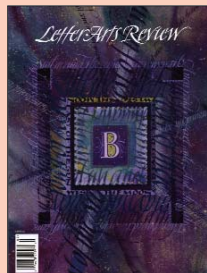

LR20.2. Word+Craft Issue. 2006. 64pp. 8.5x11. **\$17.50. Available now.**

Presents the works displayed at Word+Craft, an international calligraphy exhibit. Selected scribes from throughout the world were invited to send pieces. Presents both the works of master scribes and highlights the work of calligraphers from the Carolinas. 66 pieces including legible and non-legible, traditional and non-traditional pieces, many reproduced in full color. See page 9 & 58 for more Letter Arts Review issues and subscription information.

Brody Neuenschwander

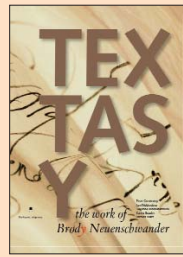

B2917. Textasy: The Work of Brody Neuenschwander. 2006. 168pp. 9"x12.25". Hardcover \$90.00. Introductory price **\$75.00** through 1-31-07

New Brody Neuenschwander uses his virtuosity to make complex works of art that

cause the viewer to look, and read, and look again. He and/or his work has been featured at three of the international calligraphy conferences: Confluence, Experiment, and Legacies. His work is included in most all *Letter Arts Review* annual issues.

This wonderful volume presents his calligraphic collages on paper and a pictorial overview of his letterscapes for cinema, theatre and architecture – collaborative projects with filmmaker, Peter Greenaway. Neuenschwander's writing is on layers of paper, naked skin and monumental walls. Superbly designed by Nej de Doncker, this lovely book is bound in cloth and printed on two types of paper – one for the full color and the other for the text. Though printed and published in Belgium, the book is in English.



B2918. Fragments de Memoires by Casanova. 2005. 6.25"x12.5". Paper \$50.00. Introductory price **\$48.00** through 1-31-07

New The text is accompanied by collages by Brody Neuenschwander. The collages include writing, typographic text, calligraphic letters & marks, old photos, and a quill. Full color throughout. Text in French.

Tom Perkins

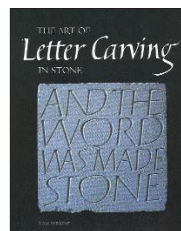

B2914. The Art of Letter Carving in Stone by Tom Perkins. 2006. 192pp. 8.5"x11". Hardcover **\$50.00**

New For the beginning and more experienced lettercutter, this how-to manual first covers the basics of letter carving, drawn lettering, and making simple designs in stone. It includes development of 20th-century letter carving; tools, materials, stone, making an easel; drawing a range of alphabets for use in letter carving; inscriptions, gilding, and painting letters; detailed instructions for V-incising the keystrokes of letters; designing headstones & plaques. Gallery of contemporary letter carvers' work. 380 color photos and diagrams.

Tom Perkins will teach at North Carolina's Cheerio Calligraphy Workshops, September 23-28, 2007. Contact Jim Teta: tetascribe@triad.rr.com



Letter Arts Review

Since 1982 *Letter Arts Review* has been the singular international journal which has served the calligraphic and lettering arts community thoughtfully, imaginatively, and provocatively. We've consistently provided informative articles, considered commentary, and outstanding reproductions. Each carefully designed issue is meant to inform, inspire, and invigorate. Whether the work you seek is contemporary, historical, experimental or traditional, commercial or fine-arts oriented, legible or nonlegible, verbal or non verbal, your subscription to *Letter Arts Review* will keep you abreast, aware, awed, and

absorbed – immersing you in a shower of inspiration anytime, night or day, day or night.

Subscribe Today! Current rates good through 12-31-06

And soon you will be savoring your personal copies of **Letter Arts Review**.

Subscriptions: (all prices in US dollars)

☞ FOUR ISSUES (**one year**)

USA: \$45 Canada \$49 All others \$67

☞ EIGHT ISSUES (**two years**)

USA \$81 Canada \$87 All others \$115

Back Issues

For annual and special issues of LAR see page 9. For many more back issues see www.johnnealbooks.com



LR16-4. Letter Arts Review Volume 16 No. 4. \$12.50

What is our Guiding Idea? *Steven Skaggs*; The Eadwine Psalter *Stan Knight*; Standing Stones *Richard Kindersley* (cover); The Graceful Envelope *Jordenne Ferrington*; LAR Gallery

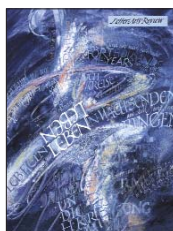

LR17-1. Vol 17, No 1 \$12.50

Articles include: What is Our Guiding Idea? (Part 2) *Steven Skaggs*; The Critic's Eye *Rose Folsom*; Glen Epstein *Anne Binder*. Cover: *Joan Coates*



LR17-2. Vol 17, No 2 \$12.50

Articles include: What is Our Guiding Idea? (3) *Steven Skaggs*; William Morris *Adela Spindler Roatcap*; Taking Time, Turning the Page: *Nancy Leavitt Donna Gold*; Lieve Cornil *Ewan Clayton*; Writing, Argument & Contemplation: *Izzy Pludwinski Christopher Calderhead*; Hans Tisdall *Michael Harvey*. Cover: *Lieve Cornil & Betina Miemietz*



LR18-1. Vol 18, No 1 \$12.50

Articles include: The Making of Sumi Ink *Christine Flint Sato*; Profile: CC Elian *Rose Folsom*; In Their Own Words: *Yumi Tohyama, Joachim Propfe and Judith Osborne* discuss their work; American Penmen *Joseph Vitolo*. Cover: *Joachim Propfe*



LR18-2. Vol 18, No 2 \$12.50

Articles include: Sacred Words: Ancient Indian Manuscripts *Brinda Gill*; The Altar Bible *Rose Folsom*; LAR Gallery; Lazar El Lissitzky: Unchained Letterform *Adela Spindler Roatcap*; Bartolomeo Sanvito *Paul Shaw*; Kate Greenaway:

Letters & Illustration in Harmony *Frances Spiegel*. Cover: *Sheila Waters*, The Alter Bible



LR18-4. Vol 18, No 4 \$13.50

Articles include: Sonia Delaunay: Color, Rhythm, Simultaneity *Adela Spindler Roatcap*; Fude: Brushes *Christine Flint Sato*; Edward Johnston Foundation *Gareth Colgan*; LAR Gallery: Three Exhibitions; Ornamental Signatures *Robert Hurford*.

Cover *Ewan Clayton, Janaeck and His Muse*



LR19-2. Vol 19, No 2 \$13.50

Articles include: Georgia Deaver: Her Brush & That Line *Christine Colasurdo*; Bartolomeo Sanvito: Part 2 *Paul Shaw*; The Work of the Sofer *Frances Siegel*; LAR Gallery; Finding the Form of an Ancient Text *Robert Bringham*; Video Review. Cover *Thomas Ingmire*

Cover *Thomas Ingmire*



LR20-1. Vol 20, No 1 \$13.50

Articles include: Maya Huber: Of Music and Stories *Stephen Skaggs*; The Exhibition of the Saint John's Bible at the Minneapolis Institute of Arts *Christopher Calderhead*; Berthold Wolpe and His Typeface *Albertus Owen Williams*; A

Calligraphic Odyssey *Rise Gettler*; The Voynich Manuscript *Frances Spiegel*. Cover: *Thomas Ingmire*

Shipping for back issues only orders

USA: Add \$2 first issue / \$1 each additional issue
CANADA: Add \$3 first issue / \$1 each additional issue
ALL OTHERS: SURFACE: Add \$5 first issue / \$2 each additional issue. AIR: \$8 first issue / \$4 each additional issue.

Back issue sale! Through Feb 28, 2007 back issues (20.3 and earlier) of *Letter Arts Review* are only \$10 each. The sale price won't be reflected on your web shopping cart, but you will be charged the correct price.

COLORED PENCILS

Prismacolor Colored Pencils. We now stock sets of regular color pencils, the harder verithin color pencils and watercolor pencils.



Verithin Colored Pencils.

These quality colored pencils feature a high strength lead that won't snap under normal writing pressure. Dense structure of pigments provide vivid colors that won't smear or fade. Takes a fine

point in any sharpener every time.

Good for lettering.

S471. 24 colors. \$14.16 **JNB \$12.95**

S472. 36 colors. \$21.24 **JNB \$19.95**

Prismacolor WATERCOLOR Pencil Sets. Artist-quality, water-soluble. Use wet or dry.

S521. 12 colors. \$16.35 **JNB Price \$14.95**

S522. 24 colors. \$32.05 **JNB Price \$28.95**

S523. 36 colors. \$48.92 **JNB Price \$43.95**

Prismacolor PREMIER Pencil Sets. Artist-quality, soft thick leads, strong lightfast properties.

S524. 12 colors. \$16.32 **JNB Price \$14.95**

S525. 24 colors. \$32.64

JNB Price \$28.95

S526. 36 colors. \$48.26

JNB Price \$43.95

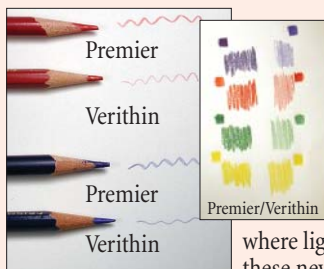

Prismacolor Premier LIGHTFAST Colored Pencils.

For work where lightfastness is critical, use these new pencils. This is the

only set that meets the lightfast standards developed in collaboration with the Colored Pencil Society of America. Thick, soft cores. Rich colors.

S528. 12 Colors. \$23.05 **JNB Price \$20.95**

S529. 24 Colors. \$46.05 **JNB Price \$41.95**

See johnnealbooks.com for info:

B2744. Colored Pencil for the Serious Beginner: Basic Lessons for Becoming a Good Artist by Bet Borgeson. 1998. 128pp. 7"x9". Paper \$19.95. **JNB Price \$18.95.**



PA42. Fabriano Ingres Pad.

Fabriano Ingres is one of our best sellers in large sheets.

Calligraphers like its warm, creamy off-white color and receptive surface for writing. The slight texture of the laid finish adds interest. With 40 sheets of

9.5"x12.5", it's priced a bit less than full sized sheets. So you get a fine calligraphy paper in convenient pad format. Mould-made. Acid Free. \$12.40. **JNB Price \$11.95** 2+ pads \$10.95ea.



S417. Excel Deluxe Knife

S417. Excel Deluxe Knife. It's time to upgrade.

This American-made knife has a soft handle, a no-roll feature, much sharper blades and best of all it's PURPLE. It's no more expensive than X-acto's basic knife!!! Safety Cap, #11 Blade. **\$3.75**



S130. Excel Blade #11. The standard pointed blade. 5

blades **\$1.50** 10 blades **\$2.90** Box of 100 **\$19.99**

S129. Excel #10 Blades. Carbon Steel. Super sharp,

double honed blades. 5 blades **\$2.10**

See page 63 for scalpels

See page 61 for paper/board cutters

See page 34 for index



Blank Watercolor Cards and Envelopes.

Card is 140 lb, cold press watercolor paper. 5.25"x7.25". For calligraphy and illustration. From Canson.

C45-6. Pkt of 6 cards and 6 envelopes.

\$5.25 Sale \$4.95 3 or more \$4.50 each

C45-30. Pkt of 30 cards and 30 envelopes.

\$21.00 Sale \$19.95 2 or more \$18.50 each

Sale ends 02/28/07



Classic Social Stationery

C49. Renaissance Card & Envelope Gift Set by G. Lalo of

Paris. 50 Cards: Off white laid Finish, 25% cotton paper,

straight edge, 5-1/4"x 3-1/2". 50 matching tissue lined envelopes. In a two-part paper covered board box with a clear panel in the lid. The tray that holds the stationery is covered with off white laid finish paper. The lid that slides over the tray is covered in blue and white with a gold G. Lalo label. Makes an impressive gift. **\$56.00. JNB Price \$32.** 2/\$30ea. *Limited supply.*



S506.

sale

S506. "Prestige" Leather Journals. Black leather cover. 25% cotton, neutral pH, off-white 26.6 lb. laid paper. Text block is lined with rounded corners, silver gilded edge, ribbon marker, 100 sheets. Can be slipped out of cover. 5.75"x8.25". **\$34.00. JNB Price \$19.95.** 2/\$16.95 each. *Limited Stock.*

See page 36 for ordering information, including shipping charges.

Order on line at www.johnnealbooks.com 24 hours a day



ORIENTAL CALLIGRAPHY

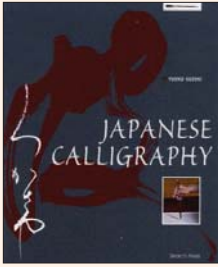

B2732. Japanese Calligraphy by Yuuko Suzuki. 2005. 80pp. 8.5"x10". Paper \$21.95. **JNB Price \$20.95**

New The Japanese use two different writing systems at the same time: kanji, Chinese characters which are

ideograms and kana which are purely phonetic characters. This beautiful book introduces Japanese calligraphy showing the way these two are combined. It contains clear, concise instruction & wonderful examples. The book is a joy, even if you have no intention of attempting Japanese calligraphy.

S393. Chinese Seal Set. Carved soap stone seal, porcelain dish of red seal ink, a small wooden stand to display your seal. All in a fabric covered box. I found these in Chinatown in San Francisco priced at \$24.95. *Double Happiness, a perfect wedding or anniversary gift.* **JNB Price \$18.99**

S394. Red Seal Ink. 2.5" dia. metal tin. **\$3.50**

See johnnealbooks.com for these and more books:

B2738. Chinese Calligraphy Made Easy: A Structured Course in Creating Beautiful Brush Lettering by Rebecca Yue. 2004. 160pp. 7.5"x9.75". Paper \$24.95. **JNB Price \$22.50**



IS37.

IS37. Round Ink Stone with cover. 4" diameter. Comes nested in an attractive fabric lined and covered box. **\$14.99**

IS38. Hexagonal Ink Stick. Chinese. I tested a wide range of inksticks and this was the blackest. Suitable for broad edge and pointed pen. Heavy hexagonal stick decorated with a raised gold dragon. 4.75". In a glass topped box. **\$9.99**

IS39. Ink Stone / Ink Stick Set. **\$22.50**
Save \$2.50!

See page 44 for high quality Japanese Ink Sticks from Japan's premier ink stick maker.



IS38.

RULING PENS

N22.



N22. Ruling Pen. Julian Waters, Gottfried Pott, Glen Epstein & many others are using ruling pens to produce expressive letters. This ruling pen is designed specifically for lettering. You vary the line width by tilting the pen. Wood handle with brass collar & writing unit. From Synthetic Design. **\$32.**



N30. Folded Ruling Pen. **\$15.00**
Introduced at Letterforum in 1995, this innovative lettering tool has been popular ever since. Use them to produce tight "brush lettering" with a pen or for wild, fun, expressive lettering. These are the originals made by Matthew Coffin and

highly praised by Carl Rohrs and Peter Thornton as superior to others that are available.



Thomas Hoyer
www.callitype.com



N33. Thomas Hoyer Ruling Pen. Thomas uses this fine crafted, traditional ruling pen for expressive lettering. 5" nickel plated tool steel alloy. Both Thomas and this ruling pen come from Germany. He has introduced the tool at several conferences and workshops in the USA and Europe. **\$18.50**



LR13.2. Ruling Pen Issue. **\$12.50.**
This issue of *Letter Arts Review* includes Paul Shaw's 27- page article on the use of the ruling pen for calligraphy and lettering. Covers history, types of ruling pens, ink & paint, paper, technique, angles/kinetics/pressure/speed, & styles of ruling pen writing. Over 50 illustrations.

FP59. Pentel Brush Fountain Pen.

Carry an inked brush in your tool kit, pocket or purse. The synthetic fiber brush tip is a bit longer than other brush fountain pens. Has a fine point and a great spring back. Highly recommended by Karen Charatan.



It is a little stiffer than the Pentel Color Brush (FP57, \$8.50), and therefore a little easier for beginners to control.

\$17.50. Sale \$16.99

FP60. Pentel Fountain Pen Cartridges.

Box of 4 cartridges. Black. **\$5.25**

TRIMMERS

We use a rolling trimmer for all our paper cutting here at John Neal, Bookseller. They let you make smooth and accurate cuts quickly. You don't have the problem with paper shifting during the cut as you do with a lever cutter. For smaller projects, the personal trimmer is sufficient. The 20-1/8" cutter would allow you to cut most art papers we sell which are typically 19"x25". You will need the larger size for watercolor papers that come 22"x30".

Each model features a ground circular blade enclosed in a plastic housing to prevent accidents. Self-sharpening blade which cuts in either direction. Automatic see-through paper clamp to prevent paper shifting. Metal base with preprinted guides for precise cuts.

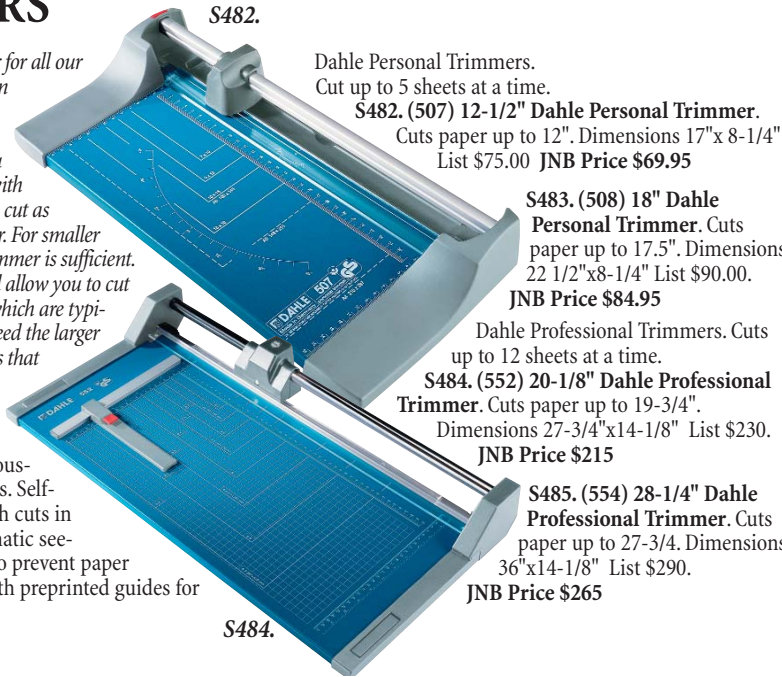

Dahle Personal Trimmers.
Cut up to 5 sheets at a time.
S482. (507) 12-1/2" Dahle Personal Trimmer.
Cuts paper up to 12". Dimensions 17"x 8-1/4"
List \$75.00 **JNB Price \$69.95**

S483. (508) 18" Dahle Personal Trimmer. Cuts paper up to 17.5". Dimensions 22 1/2"x8-1/4" List \$90.00.
JNB Price \$84.95

Dahle Professional Trimmers. Cuts up to 12 sheets at a time.
S484. (552) 20-1/8" Dahle Professional Trimmer. Cuts paper up to 19-3/4". Dimensions 27-3/4"x14-1/8" List \$230.
JNB Price \$215

S485. (554) 28-1/4" Dahle Professional Trimmer. Cuts paper up to 27-3/4". Dimensions 36"x14-1/8" List \$290.
JNB Price \$265

Kutrimmer Paper & Board Trimmer. Solid, all-metal construction and highest grade Solingen steel blades. Pressure clamp to hold board/paper, adjustable alignment bar, extension guide, and guides calibrated in 16ths of an inch. Capable of cutting a single sheet of binders board up to .098" thick.

Accurate and easy to use. Made in Germany.

S486. Kutrimmer 1038. 14" cutting length. Dimensions: 16"x14". List \$499 **JNB Price \$449**

S487. Kutrimmer 1058. 22" cutting length. Dimension: 24" x 14". List \$749
JNB Price \$674

S488. Kutrimmer 1071. 28" cutting length. Dimensions: 29" x 20". List \$949 **JNB Price \$854**



S565. Kutrimmer 1035. 13.75" cutting length. Dimension: 15.25" x 9-5/8". \$215.
JNB Price \$194

S570. Kutrimmer 2035. 13-3/4" cutting length. Dimension: 15.25"x9-5/8". \$261. **JNB Price \$234**

S571. Kutrimmer 1043. 17" cutting length. Dimension: 19" x 14.25". \$423. **JNB Price \$381**

S572. Kutrimmer 1080. 31-1/4" cutting length. \$1,440. Dimension: 32" x 24.5". **JNB Price \$1,295**

S573. Kutrimmer 1110. 43-3/4" cutting length. Dimension: 44" x 30-3/8". \$2,115.
JNB Price \$1,905

Please give a street address for UPS delivery. AK, HI, PR we can give you shipping options and cost. Your Kutrimmer may be shipped separately from the rest of your order.

BOOK & PAPER PRESS

While this was designed as a paper press it makes an excellent book press at an affordable cost. Delivers 2000 lbs of pressure. This high quality press is made of Baltic birch plywood with a professional finish. Easily moved from one location to another. Ships fully assembled, maintenance free. For paper makers: Paper dried slowly under pressure yields a smoother, flatter, harder surface and is less likely to feather ink.

S489. Book Press. For books/papers up to 8.5"x11". List \$260. **JNB Price \$219**

S490. Large Book Press. \$299. **JNB Price \$265**



BOOKBINDING SUPPLIES

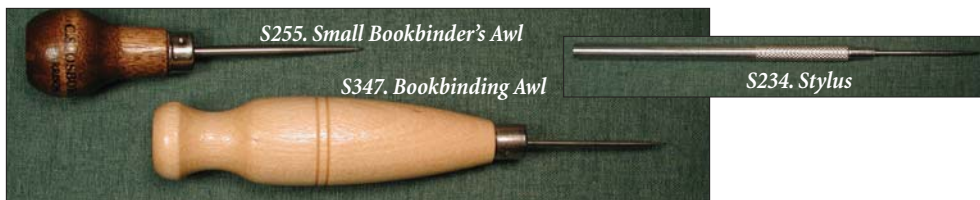

Awls

S347. Bookbinding Awl. 3-1/4". For punching holes in signatures. Finer shaft than our other awl. **\$7.00**

S234. Stylus. This inexpensive tool can be used to punch holes in a few sheets of paper before sewing. Sturdy all metal construction. Great for beginners' classes because of its low cost. **\$2.25** 10/2.15ea

S255. Small Bookbinder's Awl. Small awl with a wooden handle for punching holes in paper and thin board. **\$3.99** 12/\$3.85ea. 24/\$3.65ea. 36/\$3.35ea.

S579. Short Needle Stylus. Similar to our regular stylus, but with a needle that is much shorter. Used by Catherine Burkhardt for her sewn single sheet binding. **\$3.50**

S580. Vise. Holds a bookbinding needle to create a slim stylus set at the length you desire. **\$10.00**

Punches, Drills

Use these professional tools to create books, journals and photo albums.



S348. Japanese Push Drill

S348. Japanese Push Drill. Hollow point drills cut holes in papers, leathers, and binders board. Pressure on

wooden shaft causes drill to spin and cut hole. Set of 7 interchangeable drills: 1, 1.5, 2, 2.5, 3, 3.5, 4mm. A marvelous tool worth the price. **\$69.95**

Replacement Drills. Specify Size:

S370-1, -1.5. 1mm, 1.5mm. **\$11.20** ea.

S371-2, -2.5. 2mm, 2.5mm. **\$9.20** ea.

S372-3, -3.5, -4. 3mm, 3.5mm, 4mm. **\$8.40** ea.

S349. Single Hole Paper Drill. McGill Model 56000. Easy to use. Drills a clean whole 1/4" in diameter. Maximum capacity of 250 sheets of 20lb paper. Adjustable hole position. **\$29.95**



S358. Three Hole Paper Drill

capacity of 250 sheets of 20lb paper. Adjustable hole positions. **\$59.95**

Aluminum Screw Posts

S350-1/4. 1/4" Pkt of 10 **\$2.50**

S350-3/8. 3/8" Pkt of 10 **\$2.50**

S350-3/4. 3/4" Pkt of 10 **\$2.90**

S350-1. 1" Pkt of 10 **\$4.35**

S350-SET. Pkt. 4 of each. **\$5.20**

S358. Three Hole Paper Drill. McGill Model 57000.

Easy to Use. Drills 2 or three holes, 1/4" in diameter. Maximum

Knives

These paring knives are used in leather binding

S498. French Paring Knife. A 'French' Style paring knife with carbon steel blade and beech Handle. Suitable for both right and left handed users. **\$28.95**

S497. English Paring Knife. Specify RH or LH. **\$15.50**

S499. Clip Point Knife. Carbon steel. Beech wood handle. From the UK. 4.5" blade. **\$13.50**

See page 21 for the Bookwizard tool.

See pages 20-21 for more bookbinding supplies.



Folders

S281. Scoring Tool. Used for scoring paper. Fits comfortably in your hand. Genuine bone. List \$5.50. **JNB Price \$4.50**

S117-6. Basic

Bone Folder. For folding, scoring, and burnishing. Made of genuine bone (cattle). One end rounded, one end pointed. 6"x3/4". \$5.50. **JNB \$4.75** 6/\$4.50ea. 12/\$4.25ea.

S308. Bone Folder. 6"x3/4". Higher quality than our basic bone folder. **\$6.50.** 6/\$6.25ea. 12/\$6.00 ea.

S117-H. Horn Folder. Made from cow horn. Black. 6"x7/8". Smoother and harder than bone. \$6.49 **JNB \$5.95**

S279. Mini Bone Folder. 4-3/8". \$4.50. **JNB Price \$3.85**

S543. Ergo Folder. Specifically designed to facilitate folding and compressing signatures and manipulating paper on boxes and books. Made of a Teflon like material. 4.25" **\$25.95**

Teflon Folders. Will not glaze or mar delicate papers or fabrics. One end pointed, one end straight.

S346-S. Small 5.25"x5/8"x.25" **\$19.50**

S346-L. Large 6.25"x.75"x3/8" **\$22.50**

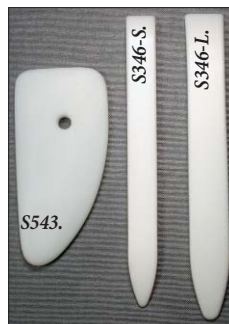

See page 2-8 for books on Binding.
See page 12 for books on Paste Paper,
Scrapers and Art Paste.

Needles

Bookbinder's Needles. From England.
S213-SH. #18 Sharp. Pkg of 6. \$2.55
S213-BL. #18 Blunt. Pkg of 6. \$2.00
S219. #15 Sharp. Pkg of 6. \$2.55
S218. Curved. Pkg of 3 assorted. \$4.85
#15 accepts thicker thread than #18.

Thread

Colored Irish Linen Thread. Unwaxed. 50 gram spool. Specify color. Burgundy, Olive Green (Tannish Green), Brown, Black, Blue, Yellow
S287. 12/3 \$12.50
S288. 18/3 \$13.25



Colored Irish Linen Thread.

Unbleached Linen Thread. From the UK. 100% Flax. Unwaxed. 50 Gram spool.
S351. 12/3 Approx 127 yd. \$10.50
S352. 18/3 Approx 172 yd. \$11.45
S353. 35/3 Approx 335 yd. \$13.50
 The same unbleached linen thread in a smaller quantity. **S310. 35/3.** 50 yards. \$4.95



Unbleached Linen Thread.



Bone Clasps

S223. 1-1/2" S222. 1-1/4" S221. 1" S220. 3/4"

Bone Clasps or Lid Pins. For use in Japanese and other bindings. These are bone, not plastic. Sizes are approximate:

S220. 3/4" \$1.25 \$13.00/dozen
 S221. 1" \$1.50 \$15.75/dozen
 S222. 1-1/4" \$1.95 \$20.00/dozen
 S223. 1-1/2" \$2.25 \$24.50/dozen

Bone Clasp Assortments.

S224-2. 2 each of the four sizes. \$13.00
 S224-6. 6 each of the four sizes. \$36.00

Book Board/Cloth, etc.

New Davey Board. Single ply, dense, acid free bookbinding board. Highest quality. 9"x13". Grain runs short. For most bookbinding and box making needs, the .080/.082 (apprx. 3/32") is recommended. Smaller books use .060/.067 to .074.
S510. .060/.067 6 sheets. \$11.50 2/\$11.00
S511. .074 6 sheets. \$12.50 2/\$12.00
S512. .080/.082 6 sheets. \$13.50 2/\$13.00

S513. Standard Book Board. Acid Free. High quality. Similar, but slightly less dense (heavy) than Davey Board. Grain runs short - .088 thickness. 9-1/2"x13". 6 sheets. \$10.25

S289. Beeswax. Natural beeswax. Use to lightly wax thread. 1oz cake. \$1.95

S438. 20 Bookmaking Bands. Use these extra strong black rubber bands to make an elegant, but quick and easy binding. You supply the stick or thin dowel. Pack of 20. \$2.75

S439. Book Tape. Acid-free gum lined tape. 1-1/2" wide. In white. 1 yard. \$2.25

S527. Linen Tape. 3/8"x60" length. \$6.00

S516. Headbands. Ivory 60". \$3.50

Scalpel. Sharpest surgical blades available for cutting, trimming, & scraping. Disposable blades snap onto handle.

S373. Scalpel Metal Handle. \$5.30

S374. #23 Scalpel Blades. \$.60 each, 10/.55 each. 25/.50 each



S516.

Bookbinding Fabrics. These are used in book making and repair generally for the spine or for connecting the book to the case. Will be available in January 2007. See www.johnnealbooks.com for more details then.

Super (Mull or Crash). Open weave material used for attaching book to case.

Hinge Cloth. Use under cloth for a stronger hinge

Stretch Linen. Used for hollow bindings.

Irish Linen. For spine support in adhesive bindings or antique books with fragile spines.

Book Cloth. Standard solid color cloth. 100% rayon, acid free, paper backed. Specify Color: Black, Ivory, Red, Navy, Burgundy, Forest Green, Beige, Olive, Lt Brown, Purple, Linen, Chocolate, Grey.

BCS-Color. 17"x19" \$5.50 BC-Color. 17"x38" \$10.00

Emerald, Sienna, Magenta, Blueweave, Black-Ivory:

BCS-Color. 17"x19" \$6.50 BC-Color. 17"x38" \$12.00

Linen: BCS-Linen 17"x19" \$8 BC-Linen. 17"x38" \$14.25



Larry Orlando



*Deanne and Peter Hattersley
request the pleasure of your company
at the marriage of their daughter*

Laura Anne

to

Matthew Robert Hegarty

*On Thursday, the twenty-fifth of September
Two thousand and four
at half after four o'clock
Petaluma County Club
Montevideo, California*

*Dinner and dancing under the stars
to follow*

Yvonne Miller

Mo Seder

*Crystal Dawn
to
Christopher Howard Herman*

Pat Blair

Kaye Hanna



PRSRT STD
US Postage
PAID
Ripon, WI
Permit No. 100

John Neal Bookseller
1833 Spring Garden Street
Greensboro, NC 27403

current resident or

BOOKBINDING & CALLIGRAPHY & PAPER-CRAFT

© 2006

Now Available!

New

B2769, Foundations of Calligraphy by Sheila Waters. 2006. 126pp. 9"x11.25". Concealed spiral binding \$35.00 **\$29.95 introductory price.** USA orders are shipped free via media mail. Foreign orders of 10 or more copies are shipped free (via Surface M-Bag). **Free shipping & intro price offers good only through December 31, 2006. Order your copy today!**

For more info on Sheila's new book, see page 7. INDEX is on page 34.

