

NEW STAR

PARTS COMPONENT GROUP

June 2008

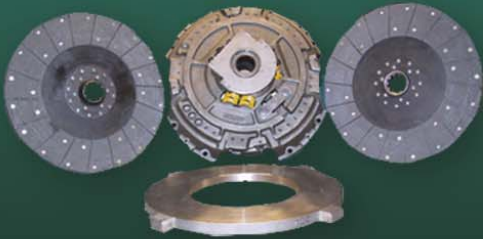

DRIVE TRAIN CATALOG

DISCLAIMER

This **NEW★STAR** Drivetrain Catalog provides information on various replacement components offered by S&S Truck Parts, Inc. / **NEW★STAR** Parts Component Group. We have extensively examined the material provided to assure accuracy and reliability. However, this information should only be used to assist the user in identifying the product we are offering as a replacement.

Trademark Acknowledgements

S & S Truck Parts, Inc. / **NEW★STAR** Parts Component Group use of the names of original manufacturers, their models, types, part numbers and other descriptive product information is only for the purpose of aiding customers in cross-referencing to the appropriate S&S/ **NEW★STAR** part. The following is a listing, compiled to the best of our knowledge, of Trademarks used in this catalog for the aforementioned purpose.

ALLISION is a trademark of GENERAL MOTOR CORP
ARVIN MERITOR is a trademark of MERITOR TECHNOLOGY, INC.
CHRYSLER is a trademark of DAIMLER CHRYSLER CORP
CLARK is a trademark of DANA CORP.
DANA® is a trademark of DANA CORP.
EATON / FULLER is a trademark of DANA CORP.
FORD is a trademark of FORD MOTOR CORP
FREIGHTLINER is a trademark of FREIGHTLINER LLC.
GM is a trademark of GENERAL MOTOR CORP
INTERNATIONAL TRUCK is a trademark of INTERNATIONAL TRUCK & ENGINE CORP

MACK is a trademark of VOLVO WORLD CORP.
MUNCIE is a trademark of MUNCIE POWER PRODUCTS, INC.
NEW PROCESS is a trademark of NEW PROCESS CORP
NEW VENTURE is a trademark of NEW VENTURE CORP
PAI / EXCEL is a trademark of PAI INDUSTRIES
RICHMOND is a trademark of RICHMOND GEAR CORP
STRANGE is a trademark of STRANGE GEAR CORP
TIMKEN is a trademark of TIMKEN CORP
TTC is a trademark of TRANSTECHNOLOGY CORP
WARNER is a trademark of BORG WARNER CORP

TABLE OF CONTENTS

REPLACEMENT PARTS FOR TRANSMISSION

INDUSTRY NUMBERS	
A CROSS SECTION OF CLARK,GM,INTERNATIONAL TRUCK,NEW PROCESS AND WARNER TRANSMISSION	
GEARS BY INDUSTRY PART NUMBERS	1 - 6
ALLISON APPLICATIONS	
GEARS AND PARTS	11
ARVIN MERITOR APPLICATIONS	
REPLACEMENT AIR VALVES	11
GEARS AND PARTS	12 - 13
CHRYSLER APPLICATIONS	
A535 LIGHT DUTY DODGE DAKOTA	13
EATON / FULLER APPLICATIONS	
GEARS AND PARTS	14 - 55
SYNCHRONIZERS	56
RANGE VALVES	57
AIR VALVES	58 - 59
MID-RANGE MEDIUM DUTY	60 - 62
FORD APPLICATIONS	
GEARS AND PARTS	62
GEARS AND PARTS - MAZDA / TOYO KOGYO	63
GEARS AND PARTS - MITSUBISHI 5-SPEED	64
GEARS AND PARTS - ZF S5-42 SERIES	65 - 66
GM / MUNCIE APPLICATIONS	
GEARS AND PARTS	69
INTERNATIONAL TRUCK APPLICATIONS	
GEARS AND PARTS	70
MACK APPLICATIONS	
GEARS AND PARTS	71 - 72
NEW PROCESS APPLICATIONS	
GEARS AND PARTS	73 - 75
NEW VENTURE APPLICATIONS	
GEARS AND PARTS	79 - 80
TTC APPLICATIONS	
GEARS AND PARTS	84 - 90
REPLACEMENT TRANSMISSION BEARING, SEAL AND GASKET KITS	91 - 92

GENUINE PARTS FOR TRANSMISSION

WARNER APPLICATIONS	
GEARS AND PARTS	7 - 10
ZF APPLICATIONS	
GEARS AND PARTS	67 - 68
NEW PROCESS APPLICATIONS	
GEARS AND PARTS	76 - 78
NEW VENTURE APPLICATIONS	
GEARS AND PARTS	81 - 83

CLUTCH AND FLYWHEEL ASSEMBLIES AND PARTS

NEW CLUTCH ASSEMBLIES	93 - 96
CLUTCH ALIGNMENT TOOLS	97 - 98
CLUTCH BRAKES	99 - 100
CLUTCH BELL HOUSING COVER KITS AND HOSES	101
MISCELLANEOUS CLUTCH PARTS	102 - 105

PLEASE NOTE

S&S TRUCK PARTS, INC. HAS MADE USE OF THE MOST RELIABLE AND BEST SOURCES OF INFORMATION TO ATTEMPT TO CORRECTLY IDENTIFY ALL APPLICATIONS / INTERCHANGES SHOWN IN THIS CATALOG. HOWEVER, WE DO NOT ASSUME ANY RESPONSIBILITY FOR POSSIBLE ERRORS.

ANY REFERENCES MADE HEREIN TO ARVIN MERITOR, BORG WARNER, CHICAGO RAWHIDE, CHRYSLER, CLARK, DANA®, DANA®(FORMERLY HILLARD), TTC, DANA®(FORMERLY EATON), EATON/FULLER, FEDERAL MOGUL, FOOTE AXLE, FORD, FREIGHTLINER, GENERAL MOTORS, INTERNATIONAL TRUCK, LIPE, MACK, MUNCIE, NATIONAL, NEW PROCESS, NEW VENTURE, PAI, RICHMOND, AND ZF ARE PURELY FOR IDENTIFICATION PURPOSES ONLY.

S&S TRUCK PARTS, INC. DOES NOT INTEND TO REPRESENT ANY PARTS SHOWN AS PRODUCTS MANUFACTURED BY THE ABOVE COMPANIES.

TABLE OF CONTENTS

REPLACEMENT PARTS FOR DIFFERENTIAL ASSEMBLIES

ARVIN MERITOR APPLICATIONS	
RING GEAR AND PINION SETS106 - 109
GEARS AND PARTS110 - 117
CONVENIENCE KITS118 - 119
CHRSYLER APPLICATIONS	
COMPONENT PARTS121
CLARK APPLICATIONS	
RING GEAR AND PINION SETS120
GEARS AND MISCELLANEOUS PARTS120
SUITABLE FOR DANA® APPLICATIONS	
RING GEAR AND PINION SETS121
INSTALLATION KITS CONSISTING OF ALL NEEDED BEARINGS,SHIMS,SEALS,SLEEVE,ETC.122
SUITABLE FOR DANA®(FORMERLY HILLARD) APPLICATIONS	
GEARS AND MISCELLANEOUS PARTS123
SUITABLE FOR DANA®(FORMERLY EATON) APPLICATIONS	
RING GEAR AND PINION SETS124 - 127
GEARS AND MISCELLANEOUS PARTS.128 - 134
TWO SPEED PARTS135 - 136
CONVENIENCE KITS.137
FORD APPLICATIONS	
RING GEAR AND PINION SETS138
INSTALLATION KITS139
BEARING AND SEAL KITS139
MISCELLANEOUS PARTS139
GM APPLICATIONS	
RING GEAR AND PINION SETS140
GEARS AND MISCELLANEOUS PARTS140
RING GEAR AND PINION SETS141
INSTALLATION KITS / DIFFERENTIAL SIDE GEAR AND PINION SETS142
MISCELLANEOUS AXLE PARTS143
GENUINE GM APPLICATIONS	
RING GEAR AND PINION SETS144
INTERNATIONAL TRUCK APPLICATIONS	
RING GEAR AND PINION SETS145
GEARS AND PARTS146 - 149
MACK APPLICATIONS	
RING GEAR AND PINION SETS150
GEARS AND MISCELLANEOUS PARTS151 - 152
AXLE SHAFTS	
SUITABLE FOR ARVIN MERITOR, DANA®, DANA®(FORMERLY EATON), GM, FORD AND INTERNATIONAL TRUCK AXLES153 - 154
REPLACEMENT DIFFERENTIAL BEARING, SEAL AND GASKET KITS155 - 156
REPLACEMENT DIFFERENTIAL MASTER BEARING, SEAL AND GASKET KITS157

BEARINGS AND OIL SEALS

BEARINGS	
CYLINDRICAL BEARING ASSEMBLIES158 - 159
NEEDLE BEARING ASSEMBLIES159
TAPERED ROLLER BEARINGS159 - 161
WHEEL BEARINGS	
APPLICATION:162
OIL SEALS	
SEALS SUITABLE FOR C/R AND NATIONAL163

PLEASE NOTE

S&S TRUCK PARTS, INC. HAS MADE USE OF THE MOST RELIABLE AND BEST SOURCES OF INFORMATION TO ATTEMPT TO CORRECTLY IDENTIFY ALL APPLICATIONS / INTERCHANGES SHOWN IN THIS CATALOG. HOWEVER, WE DO NOT ASSUME ANY RESPONSIBILITY FOR POSSIBLE ERRORS.

ANY REFERENCES MADE HEREIN TO **ARVIN MERITOR, BORG WARNER, CHICAGO RAWHIDE, CHRYSLER, CLARK, DANA®, DANA®(FORMERLY HILLARD), EATON, EATON/FULLER, DANA®(FORMERLY EATON), FEDERAL MOGUL, FOOTE AXLE, FORD, FREIGHTLINER, GENERAL MOTORS, INTERNATIONAL TRUCK, LIPE, MACK, MUNCIE, NATIONAL, NEW PROCESS, NEW VENTURE, PAI, RICHMOND, TTC, AND ZF** ARE PURELY FOR IDENTIFICATION PURPOSES ONLY.

S&S TRUCK PARTS, INC. DOES NOT INTEND TO REPRESENT ANY PARTS SHOWN AS PRODUCTS MANUFACTURED BY THE ABOVE COMPANIES.

OUR QUALITY CONTROL LABORATORY



COORDINATE MEASURING MACHINE (CMM)

FOR CHECKING LENGTHS, LOCATIONS, CONCENTRICITY OF DIAMETERS, FLATNESS AND MORE.



CNC OPTICAL COMPARATOR

FOR VISUAL CHECKS OF FORMS, RADIUS, LENGTHS, HEIGHTS AND MORE.



GLEASON UNIVERSAL GEAR TESTER

FUNCTIONAL ROLLING MACHINE FOR TESTING GEAR SETS.



CNC GEAR CHECKER / KLINGELNBERG HÖFLER

CHECKS ALL GEAR TOOTH DIMENSIONS TO INSURE TEETH ARE MADE CORRECTLY.



MITUTOYO HR-500 ROCKWELL HARDNESS

MEASURES ROCKWELL HARDNESS OF VARIOUS METALS AND OTHER MATERIALS IN THIRTY DIFFERENT HARDNESS SCALES.



CUSTOM ENGINEERED FIXTURES

ENABLE TESTING TO ORIGINAL SPECS FOR POP-OFF, PRESSURE DIFFERENTIAL, AND CRACK PRESSURES AS REQUIRED BY PART NUMBER ON ALL AIR VALVES.

S & S TRUCK PARTS, INC. HAS EXCLUSIVE CONTRACTS WITH STATE-OF-THE-ART FACTORIES THROUGHOUT NORTH AMERICA, EUROPE AND ASIA FOR THE MANUFACTURE OF **NEWSTAR** COMPONENTS.

S & S PROVIDES IT'S CUSTOMERS WITH GUARANTEED QUALITY PARTS.

OUR COMMITMENT TO QUALITY EXTENDS FROM OUR MANUFACTURING PROCESS TO OUR QUALITY CONTROL LABORATORY (QCL). THE QCL LOCATED AT OUR HEADQUARTERS IN SCHAUMBURG, ILLINOIS CONTAINS THE MOST ADVANCED AND SOPHISTICATED QUALITY INSPECTION EQUIPMENT AVAILABLE. SUBSTANTIAL INVESTMENTS MADE IN THIS EQUIPMENT ENSURE THAT **NEWSTAR** COMPONENTS MEET THE INDUSTRY'S MOST STRINGENT QUALITY STANDARDS.

INDUSTRY NUMBERS

LEGEND

L2	WARNER REV BOX	RB310	NEW PROCESS 542 REV. BOX
T8	WARNER T9A/98	WT310	NEW PROCESS 542
T14	WARNER T14	WT311	NEW PROCESS 445/4590
T18	WARNER T18	WT317	NEW PROCESS 7550/7590
T19	WARNER T19	T319	WARNER T18
T87	WARNER T87	WT320	I.H.C. T35/T495/T698
T98	WARNER T98	T321	WARNER T14
WT196	WARNER T9A/98	T323	NEW PROCESS 542
T208	NEW PROCESS 208 T.C.	T324	NEW PROCESS 7550/7590
WT258	NEW PROCESS 435,540,7550,7590	T325	I.H.C. T495
WT263	CLARK 265	WT326	CLARK 390
WT271	NEW PROCESS 540	T327	CLARK 282/285
WT273	CLARK 260V	T435	NEW PROCESS 435
WT275	NEW PROCESS 540	T495	I.H.C. T495
WT277	NEW PROCESS 540/541	RB540	NEW PROCESS 540 REV. BOX
WT281	NEW PROCESS 445,4590	T698	I.H.C. T698
WT283	NEW PROCESS 541/542	T750	NEW PROCESS 7550/7590
WT290	NEW VENTURE 3500/4500	T1104	WARNER T4
WT291	NEW PROCESS 435	T1105	WARNER T4,T5
WT292	CLARK 380/385	1301	WARNER T18
T301	NEW PROCESS 445/4590	1309	WARNER T19
T303	CLARK 385/387	1315	WARNER T9A/98
WT303	CLARK 385/387	T1351	WARNER T4,T5
WT304	MUNCIE SM465	T1352	WARNER T4,T5
T305	CLARK 282/285	1352	WARNER T4,T5
WT305	CLARK 282/285	T1450	CLARK CL450
WT308	I.H.C. T35		
T309	WARNER T19		

INDUSTRY NUMBERS

A CROSS SECTION OF CLARK,GM,INTERNATIONAL TRUCK,NEW PROCESS, AND WARNER TRANSMISSION GEARS BY INDUSTRY PART NUMBERS

THE FOLLOWING LIST OF TRANSMISSION GEARS, TRANSFER CASES, REVERSING BOX, FORKS AND MISC. PARTS ARE SUITABLE FOR POPULAR CLARK, GM/MUNCIE, INTERNATIONAL TRUCK, NEW PROCESS, AND WARNER TRANSMISSIONS. THEY ARE LISTED, FOR YOUR CONVENIENCE, IN NUMERICAL ORDER BY INDUSTRY PART NUMBER.

NEW STAR NUMBER	INDUSTRY NUMBER	REPLACEMENT FOR PART NUMBER	NEW STAR NUMBER	INDUSTRY NUMBER	REPLACEMENT FOR PART NUMBER
S-9470	L2-3	—	S-10281	WT-263-16ES	2601278
S-6128	L2-8	—	S-6241	WT-263-34	220280
S-6087	L2-10	—	S-7371	WT-263-34A	220279
S-6152	L2-16B	—	S-7715	WT-271-9	91967
S-7570	L2-55	—	S-6856	WT-271-18	93653
S-6154	T-8C-8A	WT-196-8	S-6242	WT-273-15	220522
S-6155	T-9-12W	WT-196-12	S-6823	WT-275-2.5	11294
S-6012	T-9A-11	WT-196-11	S-6693	AWT-275-2.5A	11580
S-6130	3AT-14-80	—	S-2501	AWT-275-2.5B	11337
S-6131	T-18-8	—	S-6845	WT-275-15	91568
S-6132	AT-18-10	1301-584-001	S-6869	WT-277-2	97753
S-6133	T-18-11	—	S-6870	WT-277-2A	97754
S-6134	T-18-12	1301-070-003	S-6714	AWT-277-2.5	13647
S-6135	T-18-31	1301-080-010	S-6846	WT-277-2.5	91581
S-6004	SP-18-50	—	S-6821	WT-277-3D	11118
S-6136	T-18-55	—	S-6821	AWT-277-3E	11118
S-6137	AT-19-2A	—	S-6754	WT-277-8	91197
S-6138	1AT-19-2.5	—	S-4108	WT-277-9A	93824
S-8748	T-19-8	—	S-3229	AWT-277-10	92683
S-6139	T-19-11	—	S-4106	WT-277-12	91383
S-8661	T-19D-11F	1309-080-001	S-3228	WT-277-15	91177
S-8661	T-19D-11	1309-080-001	S-6770	WT-277-16Q	93722
S-8418	T-19-14	—	S-6858	WT-277-16X	95553
S-6416	T-19-16B	—	S-6759	WT-277-22A	91677
S-6425	T-19-16C	—	S-5240	WT-277-31	93654
S-6150	T-19A-16E	1309-085-014	S-6844	WT-277-34	91198
S-8674	T-19A-16F	1309-085-012	S-6159	SP-277-50	—
S-6141	T-19-31	1309-080-008	S-C505	SP-277-50R	—
S-6005	SP-19-50	—	S-6820	WT-277-55	GS-540
S-6142	T-19-55	—	S-6866	WT-277-90	97348
S-6143	1AT-19-80	1309-590-008	S-6714	AWT-281-80	13647
S-7680	T-19-83	1309-091-001	S-6762	WT-281-83	92708
S-B120	SP-84-50	—	S-6835	AWT-283-2.5	13648
S-6146	T-87D-14	—	S-6686	AWT-283-2.5B	11425
S-B121	SP90A-50	—	S-6853	WT-283-9	92687
S-15240	AT-98-11	—	S-6850	WT-283-12	92508
S-10289	T-98-12	—	S-4650	WT-283-14	11370
S-6154	WT-196-8	—	S-6768	WT-283-16	93662
S-6012	WT-196-11	1315-070-001	S-4559	WT-283-16F	95286
S-6155	WT-196-12	—	S-6857	WT-283-16G	95288
S-6839	T-208-16GA	13948	S-6787	WT-283-16M	97419
S-6727	T-208-16GB	15112	S-6852	WT-283-44	92517
S-6720	T-208-16F	13779	S-6159	SP-283-50	SP-277-50
S-6730	T-208-44	15307	S-6820	WT-283-55	GS-540
S-A479	SP-208-50	—	S-2708	WT-283-81	94462
S-4969	WT-258-14	11334	S-A342	WT-290-8E	23049687
S-D653	WT-263-2B	227075	S-A341	WT-290-16E	23049683
S-6244	AWT-263-2.5	221480	S-7283	WT-291-2	96009
S-6236	AWT-263-2.5B	220255	S-7281	WT-291-2D	95991
S-6239	WT-263-11A	220273	S-5975	WT-291-2G	13082
S-10225	WT-263-11J	219409	S-6831	WT-291-2H	13185
S-6240	WT-263-15A	220278	S-6710	WT-291-2K	13288

LATEST ADDITIONS TO OUR CATALOG

EXCEPT WHERE SPECIFIED, ALL PARTS SUPPLIED ARE S&S/NEWSTAR. USE OF OTHER MANUFACTURERS' NAMES, PART NUMBERS, OR TRADEMARKS ARE FOR INFORMATIONAL AND IDENTIFICATION PURPOSES ONLY.

TRANSMISSION



INDUSTRY NUMBERS

NEW STAR NUMBER	INDUSTRY NUMBER	REPLACEMENT FOR PART NUMBER	NEW STAR NUMBER	INDUSTRY NUMBER	REPLACEMENT FOR PART NUMBER
S-6054	WT-291-2.5	95849	S-6631	WT-304-2.5	3901164
S-6865	AWT-291-2.5B	96986	S-6644	WT-304-3A	14053671
S-6690	AWT-291-2.5D	11562	S-6631	T-304-5	3901164
S-6695	AWT-291-2.5E	11582	S-6636	T-304-5A	3946776
S-6779	WT-291-3	95733	S-6636	WT-304-5A	3946776
S-6711	WT-291-3D	13527	S-6638	AWT-304-9A	3955570
S-3660	WT-291-6B	96373	S-6013	WT-304-10	3901141
S-7277	WT-291-6C	95724	S-4014	T-304-11	3901161
S-6784	WT-291-6D	96003	S-4014	WT-304-11	3901161
S-6780	WT-291-7	95734	S-6163	WT-304-11AX	—
S-6779	WT-291-8	95733	S-4016	T-304-12	476766
S-6711	WT-291-8D	13527	S-4016	WT-304-12	476766
S-7280	AWT-291-10C	95929	S-6055	WT-304-14A	3993036
S-7275	WT-291-11	95708	S-4522	T-304-15	3901165
S-6863	WT-291-11B	96914	S-4522	WT-304-15	3901165
S-5855	WT-291-11C	13528	S-6633	WT-304-16	3901176
S-7285	WT-291-12	97121	S-6632	WT-304-16A	3901175
S-7285	AWT-291-12A	97121	S-5951	WT-304-17	14020811
S-6860	WT-291-16B	96004	S-3438	WT-304-19	3932253
S-7276	WT-291-16C	95723	S-3439	WT-304-19A	3932274
S-3584	WT-291-16D	15328	S-8199	WT-304-19B	465455
S-6861	WT-291-16E	96354	S-7236	T-304-21	3901158
S-7284	WT-291-16H	96372	S-7236	WT-304-21	3901158
S-3584	WT-291-16J	15328	S-3440	WT-304-22	3901137
S-7282	WT-291-16L	95993	S-3441	WT-304-22A	3901138
S-6868	WT-291-16Q	97672	S-3440	WT-304-23	3901137
S-7278	WT-291-21	95726	S-3441	WT-304-23A	3901138
S-6782	WT-291-22B	95747	S-8208	WT-304-28	794381
S-6864	WT-291-23	96969	S-6639	WT-304-34	3968038
S-6855	WT-291-23A	93549	S-6014	T-304-36	3901170
S-3884	SP-291-50	—	S-6014	WT-304-36	3901170
S-6819	WT-291-55	GS-435	S-4040	SP-304-50	—
S-6859	AWT-291-83	95727	S-6164	WT-304-55	—
S-6866	WT-291-90	97348	S-3653	AWT-304-80	—
S-2113	AWT-292-11	218879	S-8380	WT-304-90	3830575
S-2112	WT-292-11C	218880	S-6636	WT-304-81	3946776
S-6233	AWT-292-12	216746	S-6637	WT-304-83A	3950367
S-2107	AWT-292-18	227722	S-5951	WT-304-91	14020811
S-2108	AWT-292-18B	227721	S-4841	T-305-1	237053
S-2707	AWT-292-19	226701	S-5379	T-305-1A	237054
S-6243	WT-292-19A	221143	S-8214	WT-305-2	228289
S-6260	AWT-292-80	229076	S-2099	WT-305-2A	228808
S-6714	T-301-1	13647	S-5379	AWT-305-2.5	237054
S-6878	T-301-10	99104	S-5741	WT-305-3	228580
S-2109	T-303-1	227750	S-6250	T-305-5	228307
S-2103	WT-303-2	218539	S-4843	WT-305-10	228581
S-2103	T-303-2A	218539	S-6296	WT-305-11	238199
S-2117	WT-303-3	218545	S-6298	WT-305-11A	238201
S-2111	WT-303-10	218546	S-5740	WT-305-12	228578
S-2112	AWT-303-11	218880	S-6259	WT-305-12A	228817
S-2105	WT-303-16	228603	S-4840	T-305-14	228306
S-6179	WT-303-55	GS-385	S-2709	WT-305-14	228296
S-2109	AWT-303-80	227750	S-2709	T-305-14A	228296
S-3652	T-304-1	AWT-304-2.5	S-6011	WT-305-16A	228340
S-3653	T-304-1A	AWT-304-80	S-4188	WT-305-16F	230207
S-4015	T-304-2A	3932265	S-8438	WT-305-16H	228955
S-4015	WT-304-2A	3932265	S-6297	WT-305-18	238200
S-6641	AWT-304-2C	6259663	S-6299	WT-305-18A	238202
S-6641	T-304-2C	6259663	S-9507	WT-305-22C	233797
S-3652	AWT-304-2.5	—	S-9508	WT-305-22D	233799

LATEST ADDITIONS TO OUR CATALOG

EXCEPT WHERE SPECIFIED, ALL PARTS SUPPLIED ARE S&S/NEWSTAR. USE OF OTHER MANUFACTURERS' NAMES, PART NUMBERS, OR TRADEMARKS ARE FOR INFORMATIONAL AND IDENTIFICATION PURPOSES ONLY.



INDUSTRY NUMBERS

TRANSMISSION

NEW STAR NUMBER	INDUSTRY NUMBER	REPLACEMENT FOR PART NUMBER	NEW STAR NUMBER	INDUSTRY NUMBER	REPLACEMENT FOR PART NUMBER
S-5378	WT-305-23A	233798	S-6746	WT-310-34	15596
S-7372	WT-305-31	228726	S-6742	WT-310-44	15592
S-2101	WT-305-31A	228814	S-5853	SP-310-50	—
S-6295	WT-305-44	238198	S-6820	WT-310-55	GS-540
S-6252	WT-305-44A	228314	S-6835	AWT-310-80	13648
S-6252	WT-305-44B	228314	S-2708	AWT-310-81	94462
S-6257	WT-305-44C	228348	S-2708	WT-310-81	94462
S-3885	SP-305-50	—	S-3613	AWT-310-83B	13639
S-6252	WT-305-54A	228314	S-6878	WT-311-10	99104
S-6178	WT-305-55	GS-285	S-6683	AWT-317-2.5	11368
S-4841	AWT-305-80	237053	S-6691	1AWT-317-2.5	11563
S-6250	WT-305-81	228307	S-6832	WT-317-12A	13259
S-4840	WT-305-83	228306	S-6885	AWT-317-80A	99292
S-6246	WT-305-90	222960	S-6885	WT-317-80A	99292
S-4390	AWT-308-2	238-598-R	S-6884	WT-317-81A	99291
S-2272	AWT-308-2.5	238-614-R	S-6131	T-319-8	T-18-8
S-4574	WT-308-3	863-822-R	S-6132	T-319-10	AT-18-10
S-4573	WT-308-9	238-585-R	S-6133	T-319-11	T-18-11
S-4578	WT-308-11	238-612-R	S-6134	T-319-12	1301-070-003
S-4580	WT-308-12	238-599-R	S-6135	T-319-31	T-18-31
S-A094	WT-308-16A	238-582-R	S-6004	SP-319-50	SP-18-50
S-4588	WT-308-31	863-823-R	S-2272	T-320-1	238-614-R
S-4592	WT-308-34	238-589-R	S-4390	T-320-2	238-598-R
S-5505	SP-308-50A	SP-325-50	S-4390	WT-320-2	238-598-R
S-6165	WT-308-55	—	S-7239	WT-320-2B	440-283-C
S-2708	AWT-308-81	94462	S-4546	WT-320-2C	487-875-C
S-6143	T-309-1	1AT-19-80	S-2272	AWT-320-2.5	238-614-R
S-6138	T-309-1A	1AT-19-2.5	S-4266	WT-320-2.5	474-077-C
S-6137	T-309-2A	AT-19-2A	S-4545	WT-320-2.5A	487-874-C
S-6153	T-309-2E	1309-171-008	S-4574	T-320-3	863-822-R
S-6153	T-309-2G	1309-171-008	S-4574	WT-320-3	863-822-R
S-8748	T-309-8	T-19-8	S-4271	WT-320-3A	440-276-C
S-8562	AT-309-10A	1309-584-001	S-4573	WT-320-8A	238-585-R
S-6139	T-309-11	T-19-11	S-4270	WT-320-10A	440-279-C
S-8661	T-309-11E	1309-080-001	S-4578	WT-320-11	238-612-R
S-6140	T-309-12	T-19-12	S-4580	WT-320-12	238-599-R
S-8418	T-309-14	T-19-14	S-7244	WT-320-12A	474-078-C
S-6150	T-309-16AE	1309-085-014	S-4543	WT-320-12B	487-872-C
S-6141	T-309-31	T-19-31	S-6762	T-320-14B	92708
S-6005	T-309-50	SP-19-50	S-4650	T-320-14C	11370
S-6142	T-309-55	T-19-55	S-2708	WT-320-15	94462
S-7680	T-309-83	1309-091-001	S-A094	T-320-16B	238-582-R
S-4279	WT-310-2	97848	S-4264	WT-320-16D	440-285-C
S-6886	WT-310-2A	99511	S-4263	WT-320-16F	440-287-C1
S-6811	AWT-310-2.5	11564	S-4267	WT-320-16G	440-286-C
S-6826	WT-310-3	11808	S-3665	WT-320-22A	508-054-C
S-6793	RB-310-8	97601	S-3665	WT-320-22B	508-054-C
S-6738	WT-310-9	15588	S-2526	WT-320-22C	401-097-C
S-6874	WT-310-11A	99003	S-4588	WT-320-31	863-823-R
S-3586	WT-310-12	97844	S-4544	WT-320-31A	487-873-C
S-3746	WT-310-15	97562	S-4592	WT-320-34	238-589-R
S-7287	WT-310-16A	99705	S-7245	WT-320-36	474-079-C
S-7269	RB-310-16B	11189	S-4542	WT-320-36A	487-871-C
S-7427	RB-310-16C	11239	S-4039	SP-320-50	SP-308-50
S-6842	WT-310-16E	15746	S-5505	SP-320-50A	SP-325-50
S-6873	WT-310-18A	97999	S-6166	SP-320-50B	WT-320-50B
S-6743	WT-310-18C	15593	S-6166	WT-320-50B	—
S-6759	WT-310-22A	91677	S-6165	T-320-55	WT-308-55
S-5484	WT-310-22B	93966	S-6165	WT-320-55	WT-308-55
S-6872	AWT-310-31A	97978	S-6835	AWT-320-80	13648

LATEST ADDITIONS TO OUR CATALOG

EXCEPT WHERE SPECIFIED, ALL PARTS SUPPLIED ARE S&S/NEWSTAR. USE OF OTHER MANUFACTURERS' NAMES, PART NUMBERS, OR TRADEMARKS ARE FOR INFORMATIONAL AND IDENTIFICATION PURPOSES ONLY.



INDUSTRY NUMBERS

NEW STAR NUMBER	INDUSTRY NUMBER	REPLACEMENT FOR PART NUMBER	NEW STAR NUMBER	INDUSTRY NUMBER	REPLACEMENT FOR PART NUMBER
S-6130	T-321-1C	3AT-14-80	S-6277	WT-326-11	235369
S-6811	T-323-1	11564	S-6278	WT-326-11A	235370
S-6835	T-323-1A	13648	S-6305	WT-326-11B	239353
S-4279	T-323-2	97848	S-6301	WT-326-11C	239347
S-6886	T-323-2A	99511	S-6271	WT-326-12	235363
S-6826	T-323-3	11808	S-6272	WT-326-12A	235364
S-6700	WT-323-3A	11809	S-6280	WT-326-15	235373
S-6738	T-323-9A	15588	S-6266	WT-326-16	235353
S-6874	T-323-11A	99003	S-6267	WT-326-16A	235354
S-3586	T-323-12	97844	S-6290	T-326-16C	235432
S-3613	T-323-14B	13639	S-6265	WT-326-16D	235351
S-3746	T-323-15	97562	S-6290	T-326-16F	235432
S-6842	T-323-16E	15746	S-6290	WT-326-16F	235432
S-6873	T-323-18A	97999	S-6291	T-326-16G	235433
S-6743	T-323-18C	15593	S-6275	WT-326-18	235367
S-6872	T-323-31A	97978	S-6276	WT-326-18A	235368
S-6746	T-323-34	15596	S-6304	T-326-18B	239352
S-6742	T-323-44A	15592	S-6300	T-326-18C	239346
S-5853	SP-323-50	SP-310-50	S-6274	T-326-31	235366
S-6820	WT-323-55	GS-540	S-6274	WT-326-31	235366
S-6691	T-324-1	11563	S-6273	WT-326-36	235365
S-6836	T-324-1A	13649	S-6286	WT-326-44	235390
S-6683	T-324-1B	11367	S-6287	WT-326-44A	235391
S-6825	T-324-2A	11780	S-6167	SP-326-50	—
S-6885	T-324-5A	99292	S-6168	WT-326-55	—
S-6832	T-324-12A	13259	S-6281	WT-326-81	235381
S-6884	T-324-15A	99291	S-6298	T-327-11	238201
S-7239	T-325-2A	440-283-C	S-6296	T-327-11A	238199
S-4546	WT-325-2B	487-875-C	S-6299	T-327-18	238202
S-4271	T-325-3	440-276-C	S-6297	T-327-18A	238200
S-4266	T-325-5	474-077-C	S-6295	T-327-44	238198
S-4545	WT-325-5A	487-874-C	S-4776	AT-435-2.5C	11338
S-4270	T-325-10	440-279-C	S-6686	AT-435-2.5D	11425
S-7244	T-325-12	474-078-C	S-6831	T-435-2J	13185
S-4543	T-325-12A	487-872-C	S-6710	T-435-2K	13288
S-2708	T-325-15A	94462	S-6780	T-435-7	95734
S-4264	T-325-16A	440-285-C	S-6711	T-435-8D	13527
S-4267	T-325-16B	440-286-C	S-5855	T-435-11C	13528
S-4263	T-325-16C	440-287-C1	S-6782	T-435-22B	95747
S-4544	WT-325-31A	487-873-C	S-6714	AT-445-2.5	13647
S-7245	T-325-36	474-079-C	S-9860	SP-450-50	K-2144
S-4542	WT-325-36A	487-871-C	S-7239	T-495-2	440-283-C
S-5505	SP-325-50	—	S-7239	WT-495-2	440-283-C
S-6166	SP-325-50A	WT-320-50B	S-4271	T-495-3A	440-276-C
S-6166	WT-325-50B	WT-320-50B	S-4266	T-495-5	474-077-C
S-6165	WT-325-55	WT-308-55	S-4270	T-495-10	440-279-C
S-5094	T-325-90	18-521-R	S-7244	T-495-12	474-078-C
S-6269	WT-326-2	235359	S-4543	T-495-12A	487-872-C
S-6289	WT-326-2A	235428	S-4264	T-495-16A	440-285-C
S-6270	WT-326-2B	235361	S-4267	T-495-16B	440-286-C
S-6302	T-326-2C	239348	S-2526	T-495-22A	401-097-C
S-6302	WT-326-2C	239348	S-7245	T-495-36	474-079-C
S-6279	WT-326-2.5	235371	S-5505	SP-495-50	SP-325-50
S-6282	WT-326-3	235384	S-6812	T-540-16BB	99754
S-10279	WT-326-3M	23696	S-6673	RB-540-5	11188
S-6279	T-326-5	235371	S-6675	RB-540-5A	11192
S-6281	T-326-5A	235381	S-6791	RB-540-35	97591
S-6303	T-326-5B	239350	S-8937	GS-540-RB	—
S-6284	WT-326-9	235388	S-6715	T-542-16E	13678
S-6285	WT-326-9A	235389	S-3613	AWT-542-83	13639

LATEST ADDITIONS TO OUR CATALOG

EXCEPT WHERE SPECIFIED, ALL PARTS SUPPLIED ARE S&S/NEWSTAR. USE OF OTHER MANUFACTURERS' NAMES, PART NUMBERS, OR TRADEMARKS ARE FOR INFORMATIONAL AND IDENTIFICATION PURPOSES ONLY.



INDUSTRY NUMBERS

TRANSMISSION

NEW STAR NUMBER	INDUSTRY NUMBER	REPLACEMENT FOR PART NUMBER	NEW STAR NUMBER	INDUSTRY NUMBER	REPLACEMENT FOR PART NUMBER
S-4546	T-698-2	487-875-C	S-9691	1345-689-003	—
S-4545	T-698-5	487-874-C	S-5816	T-1450-2	239785
S-4543	T-698-12	487-872-C	S-5827	T-1450-3	241018
S-4544	T-698-31	487-873-C	S-5852	T-1450-6A	239821
S-4542	T-698-36	487-871-C	S-5815	T-1450-11	239793
S-6166	SP-698-50	WT-320-50B	S-7626	T-1450-11A	239815
S-6691	AT-750-1	11563	S-5817	T-1450-12	239787
S-6836	AT-750-1A	13649	S-5821	T-1450-15	239832
S-6683	AT-750-1B	11367	S-6307	T-1450-16C	239808
S-6825	T-750-2B	11780	S-5820	T-1450-18	239792
S-6832	AT-750-12B	13259	S-5819	T-1450-31	239790
S-6884	T-750-15A	99291	S-8755	T-1450-34	—
S-8551	T-1104-14	1351-091-001	S-5818	T-1450-36	239789
S-8076	T-1105-11H	1352-080-017	S-5822	T-1450-44	241013
S-6134	1301-070-003	—	S-5823	T-1450-44A	241014
S-6135	1301-080-010	T-18-31	S-7816	T-1450-55	K-2143
S-6132	1301-584-001	AT-18-10	S-6306	T-1450-81	239791
S-8661	1309-080-001	—	S-A520	SP-3500-50	—
S-8661	1309-080-004	1309-080-001	S-A521	SP-4500-50	—
S-6141	1309-080-008	T-19-31	S-9202	T5W	—
S-8674	1309-085-012	—	S-9219	T5MK	—
S-6150	1309-085-014	—	S-9609	T82D	—
S-7680	1309-091-001	T-19-83	S-9806	T82	—
S-6143	1309-590-008	1AT-19-80	S-9827	T1356R	—
S-6012	1315-070-001	WT-196-11			
S-8552	1332-091-002	—			
S-8066	1340-080-001	—			
S-8065	1340-085-002	—			



LATEST ADDITIONS TO OUR CATALOG

EXCEPT WHERE SPECIFIED, ALL PARTS SUPPLIED ARE S&S/NEWSTAR. USE OF OTHER MANUFACTURERS' NAMES, PART NUMBERS, OR TRADEMARKS ARE FOR INFORMATIONAL AND IDENTIFICATION PURPOSES ONLY.

GENUINE GEARS AND PARTS

APPLICATION: WARNER TRANSMISSIONS

GENUINE PART NUMBER	DESCRIPTION	GENUINE PART NUMBER	DESCRIPTION
1000-012-002	MAGNET	1345-110-003	SPEEDO GEAR-NATURAL
1000-044-012	OIL SEAL	1345-110-006	SPEEDO GEAR-YELLOW
1000-044-051	OIL SEAL	1345-110-007	SPEEDO GEAR-GREEN
1000-044-054	OIL SEAL	1345-127-002	BUSHING
1000-047-016	WASHER	1345-130-001	BALL BEARING
1000-127-005	INSERT	1345-139-001	SNAP RING
1000-127-006	INSERT	1345-139-004	SNAP RING
1000-130-008	BEARING	1345-143-002	FORD DRIVE CHAIN
1000-130-011	BEARING	1345-144-001	SPROCKET
1000-132-044	NEEDLE BEARING	1345-144-004	DRIVEN SPROCKET-34T
1000-139-040	SNAP RING	1345-144-005	DRIVEN SPROCKET-34T
1000-139-041	SNAP RING	1345-156-004	PUMP PIN SPRING
1000-139-043	SNAP RING	1345-162-002	RING GEAR
1300-016-001	SEAL RING	1345-171-003	UPPER OUTPUT SHAFT
1300-016-002	SEAL RING	1345-183-003	PUMP BOLT
1300-031-006	FLANGE	1345-193-001	THRUST WASHER
1300-044-001	OIL SEAL	1345-193-003	THRUST WASHER
1300-052-003	PLUG	1345-193-005	THRUST WASHER
1300-127-011	CAM ROLLER	1345-238-001	FILTER TUBE
1300-139-009	SNAP RING	1345-410-001	HOSE KIT
1300-139-010	SNAP RING	1345-410-002	PUMP KIT
1300-139-012	SNAP RING 4416	1345-565-001	CASE HALF FRONT
1300-139-027	RETAINING RING	1345-689-003	GEAR
1300-146-003	STUD	1350-014-001	THRUST PLATE
1300-149-002	NUT	1350-035-002	DUST DEFLECTOR
1300-149-005	NUT	1350-053-002	SPACER
1300-531-005	YOKE	1350-056-004	PUMP RETAINER
1301-085-008	DRIVE GEAR	1350-089-001	REDUCTION HUB
1301-097-009	HOUSING	1350-090-001	SHIFT HUB
1301-171-006	MAINSHAFT	1350-096-004	SHIFT FORK-REDUCTION
1301-566-010	ADAPTER	1350-144-004	SPROCKET
1301-590-008	SYNCHRO ASSY	1350-156-007	SPRING
1301-596-003	SHIFT FORK	1350-156-008	TORSION SPRING
1301-597-004	TOP COVER	1350-165-001	SUN GEAR
1309-085-001	MAIN DRIVE GEAR	1350-659-008	CARRIER ASSEMBLY
1309-085-012	M.D. INPUT	1351-018-005	RACE INPUT THRUST
1309-097-003	HOUSING COVER	1351-027-001	RETAINER MAIN DRIVE
1309-590-003	SYNCHRO ASSY	1351-093-001	SHIFT PLATE
1332-091-003	SYNCHRONIZER RING	1351-096-002	SHIFT FORK
1332-093-002	SHIFT PLATE	1351-098-005	LEVER
1332-096-008	SHIFT FORK	1351-132-004	THRUST NEEDLE BEARING
1332-127-003	BUSHING	1351-156-001	SPRING
1332-127-004	BUSHING	1352-027-007	RETAINER MAIN DRIVE
1332-156-002	SPRING	1352-027-015	C.S. REAR RETAINER
1340-085-003	MAIN DRIVE GEAR	1352-034-001	FUNNEL
1340-100-002	SHIFT RAIL	1352-053-005	SPACER
1345-014-003	RING GEAR	1352-070-024	5TH DRN GEAR
1345-034-006	RUBBER TUBE	1352-070-029	DRIVEN GEAR
1345-039-005	REAR PUMP COVER	1352-077-052	COUNTERSHAFT
1345-039-007	FRONT PUMP COVER	1352-077-054	CLUSTER GEAR
1345-040-001	SPRING	1352-077-056	CLUSTER GEAR
1345-043-007	PUMP PIN	1352-077-061	CLUSTER GEAR -37-32-23-15-1
1345-056-001	SHIFT CAM	1352-077-062	COUNTERSHAFT
1345-056-005	HOSE CLAMP	1352-077-063	CLUSTER GEAR
1345-056-007	PUMP RETAINER	1352-077-068	CLUSTER GEAR
1345-090-001	SHIFT COLLAR	1352-077-070	CLUSTER GEAR
1345-096-004	LOCK UP FORK	1352-077-071	CLUSTER GEAR
1345-097-004	PUMP HOUSING	1352-080-015	3RD GEAR
1345-099-007	1345 SHIFT CAM	1352-080-017	M.S. 3RD GEAR
1345-110-002	SPEEDO GEAR-BLUE	1352-080-026	2ND GEAR

GENUINE GEARS AND PARTS

APPLICATION: WARNER TRANSMISSIONS

TRANSMISSION

GENUINE PART NUMBER	DESCRIPTION	GENUINE PART NUMBER	DESCRIPTION
1352-080-028	2ND GEAR	1356-144-003	UPPER DRIVE SPROCKET
1352-080-031	1ST GEAR	1356-156-006	TORSIONAL SPRING
1352-080-048	3RD GEAR	1356-171-007	OUTPUT SHAFT 31SPL
1352-080-114	5TH DRIVEN GEAR	1356-171-008	OUTPUT SHAFT
1352-080-119	1ST GEAR	1356-235-001	REDUCTION FORK INSERT
1352-080-126	2ND GEAR	1356-410-001	PLANETARY KIT
1352-080-131	2ND GEAR	1356-410-004	PLANETARY KIT/ W PTO
1352-080-150	2ND GEAR	1356-410-005	MOTOR ASSY
1352-080-152	GEAR	1356-531-002	YOKE FRONT & REAR
1352-085-003	MAIN DRIVE INPUT	1356-539-003	MAG COV ASSY-MECH
1352-085-008	MDG	1356-565-005	CASE ASSEMBLY
1352-085-010	MAIN DRIVE INPUT	1356-565-006	CASE ASSY
1352-085-011	MAIN DRIVE GEAR	1356-565-011	CASE ASSY-PTO MECH
1352-085-025	MAIN DRIVE INPUT	1356-566-012	TAIL HSG W/SPEEDO HOLE
1352-085-026	MAIN DRIVE GEAR	1356-598-004	SHAFT LEVER ASSY
1352-085-045	MAIN DRIVE GEAR	1356-598-005	SHIFT LEVER ASSY
1352-093-002	SHIFTER PLATE	1356-598-009	SHIFT LEVER
1352-097-015	CASE COVER	1356-599-001	CAM ASSEMBLY
1352-127-009	BUSHING	1356-648-007	MOTOR
1352-156-018	SPRING	1356-659-010	CARRIER ASSY NEW STYLE 6/9
1352-183-002	FASTENER	1356-671-005	OUTPUT SHAFT ASSY
1352-410-010	SHIM KIT	1356-671-006	SHAFT ASSEMBLY
1352-525-001	RING	1370-031-002	REAR YOKE
1352-565-008	CASE	1370-090-001	SHIFT COLLAR HUB
1352-584-008	REV IDLER ASSY-20T	1370-100-001	SHIFT RAIL
1352-590-003	SYNCHRO ASSY	1370-110-001	SPEEDO GEAR
1352-671-105	M/S ASSY	1370-110-002	ROTAR SPEEDO-40T
1353-077-001	CLUSTER GEAR	1370-144-001	DRIVE SPROCKET
1353-080-001	1ST GEAR	1370-156-001	4 LOW ASSIST SPRING
1353-080-002	2ND GEAR	1370-171-003	LOWER OUTPUT SHAFT
1353-080-003	3RD GEAR	1370-238-001	OIL STRAINER
1353-671-012	MAINSHAFT	1370-531-001	CIRCULAR FLANGE ASSY
1354-089-002	REDUCTION HUB	1370-566-008	EXTN & BUSHING ASSY
1354-096-003	LOCKUP FORK	1370-598-002	SHIFT LEVER ASSY
1354-099-002	SHIFT CAM	1370-607-002	SPACER & PUMP ASSY
1354-122-002	SHIFT SHAFT	1370-640-001	SPEEDO SENSOR
1354-144-002	DRIVE SPROCKET-9T	1370-659-004	CARRIER ASSY
1354-162-001	RING GEAR	1372-144-001	UPPER DRIVE SPROCKET
1354-212-001	CLUTCH HOUSING	1372-144-002	LOWER DRIVE SPROCKET
1354-410-003	MOTOR/BRACKET KIT	1372-162-001	RING GEAR
1354-539-001	REAR CASE ASSY	1372-625-001	VISCOUS COUPLING
1354-539-002	CASE HALF	1381-590-002	SYN ASSY
1354-596-001	SHIFT FORK ASSY	1386-087-004	6TH SPD. GR.
1354-648-023	MOTOR ASSEMBLY	1386-596-013	SHIFT FORK ASSY
1354-659-002	CARRIER ASSEMBLY	1900-034-001	OIL SCOOP
1354-671-010	SHAFT ASSY	1900-034-003	PUMP HOSE
1354-689-001	INPUT SHAFT ASSY	1900-034-008	TUBE(HOSE)
1356-014-002	PLATE	1900-034-009	TUBE
1356-034-001	HOSE COUPLING	1900-043-008	PIN
1356-053-003	SPACER	1900-044-002	OIL SEAL
1356-055-001	LOCKUP COLLAR	1900-044-009	SEAL-FRONT INPUT
1356-056-003	WIRING BRACKET	1900-044-011	OIL SEAL
1356-056-004	PUMP RETAINER CLIP	1900-044-012	INPUT SEAL
1356-089-003	REDUCT HUB	1900-044-013	OIL SEAL
1356-090-004	SHIFT COLLAR HUB	1900-044-019	OIL SEAL
1356-096-007	LOCKUP FORK	1900-047-004	WASHER
1356-099-008	CAM	1900-047-007	WASHER 4411
1356-122-001	SHIFT SHAFT-MECH	1900-052-008	PIPE PLUG
1356-122-007	SHIFT SHAFT-ELECT	1900-053-024	SPACER-SPEEDO GEAR
1356-144-002	LOWER DRIVE SPROCKET	1900-053-027	THRUST WASHER SPACER

GENUINE GEARS AND PARTS

APPLICATION: WARNER TRANSMISSIONS

GENUINE PART NUMBER	DESCRIPTION	GENUINE PART NUMBER	DESCRIPTION
1900-056-003	CONNECTOR-RETAINER	4400-238-003	FILTER
1900-056-004	J-CLIP	4400-248-001	ISULATOR WASHER
1900-056-007	HOSE CLAMP	4400-508-001	PUMP ASSY
1900-072-005	BREATHER BARB	4400-508-004	PUMP ASSY
1900-089-001	REDUCTION HUB	4400-508-006	PUMP ASSY
1900-109-002	BALL REQ.3	4400-508-013	PUMP 4416
1900-110-004	SPEEDO GEAR	4400-531-001	YOKE ASSY
1900-110-017	SPEEDO GEAR	4400-596-001	RED. FORK ASSY. W/INSERTS
1900-110-018	SPEEDO GEAR	4400-625-001	VISCOUS COUPLING
1900-127-003	BUSHING	4400-625-006	CLUTCH PACK ASSY
1900-127-012	BUSHING	4400-640-043	SENSOR-UPPER SPEED
1900-127-016	BUSHING	4400-640-044	SENSOR ASSEMBLY
1900-130-001	BEARING	4400-640-076	SWITCH
1900-130-004	BALL BEARING	4400-645-006	CLUTCH COIL ASSY
1900-130-010	BEARING	4400-645-020	CLUTCH COIL ASSY
1900-130-012	BRG. ASSY.	4400-645-022	CLUTCH COIL ASSY
1900-130-018	BEARING 4404/4410	4400-712-001	COIL HSG. ASSY
1900-130-020	BEARING 4416	4401-099-002	SHIFT CAM
1900-132-001	NEEDLE BEARING	4401-099-003	SHIFT CAM
1900-132-006	NEEDLE BEARING	4401-143-001	CHAIN-STANDARD DUTY
1900-132-008	THRUST BRG	4401-410-001	KIT-COLLAR
1900-132-009	NEDDLE BEARING	4401-410-002	SHAFT KIT
1900-132-013	BEARING 4411	4401-410-003	SHAFT KIT
1900-134-001	ROLLER BEARING	4401-565-001	CASE ASSEMBLY
1900-139-001	SNAP RING	4401-565-004	CASE ASSY
1900-139-007	RETAINING RING	4401-589-001	LOCK UP ASSY
1900-139-026	RETAINING RING	4401-598-001	SHIFT LEVER ASSY
1900-139-034	SNAP RING	4401-671-001	SHIFT ASSY
1900-139-039	RETAINING RING	4401-671-002	SHIFT ASSY
1900-139-041	RETAINING RING	4404-144-001	SPROCKET GEAR
1900-139-045	SNAP RING	4404-539-002	CASE HALF
1900-139-054	SNAP RING	4404-539-004	CASE HALF
1900-139-055	SNAP RING	4404-565-003	CASE ASSY
1900-139-057	SNAP RING	4404-671-002	SHAFT ASSY
1900-149-001	NUT	4404-671-004	SHAFT ASSY
1900-149-002	NUT	4404-671-006	SHAFT ASSY
1900-149-014	NUT 4411	4404-689-001	INPUT SHAFT
1900-156-006	WAVE SPRING	4405-099-009	SHIFT CAM-ELECT
1900-156-008	HELICAL SPRING	4405-099-011	CAM
1900-183-023	BOLT	4405-100-001	SHIFT RAIL
1900-183-034	BOLT 4411	4405-110-001	SPEEDO GEAR
1900-191-023	BREATHER PLUG	4405-144-006	LOWER SPROCKET
1900-193-005	WASHER	4405-144-008	PUMP
1900-193-006	THRUST WASHER	4405-147-004	ARMATURE
1900-193-020	THRUST WASHER	4405-151-005	tone wheel LOWER
1900-193-035	THRUST WASHER	4405-151-006	tone wheel UPPER
1900-193-045	THRUST WASHER 4411	4405-171-001	LOWER OUTPUT SHAFT
4000-410-001	BEARING-RING KIT	4405-171-008	OUTPUT SHAFT
4400-055-001	CLUTCH COLLAR	4405-179-005	HUB-CIRCULAR
4400-070-001	GEAR-PTO	4405-539-004	COVER ASSY
4400-089-002	REDUCTION HUB	4405-565-007	CASE ASSEMBLY
4400-099-001	CAM	4405-565-008	CASE ASSY
4400-143-014	CHAIN	4405-565-009	CASE ASSY
4400-143-015	CHAIN	4405-596-002	SHIFT FORK ASSY
4400-143-016	CHAIN	4405-644-001	UPPER SPROCKET ASSY
4400-143-027	CHAIN	4405-644-002	SPROCKET ASSY
4400-150-004	RUBBER DAMPER	4405-648-009	MOTOR ASSY
4400-156-001	SPRING	4405-689-001	INPUT ASSY
4400-235-002	LOCKUP FORK INSERT	4406-096-007	SHIFT FORK
4400-238-002	FILTER	4406-096-008	LOCKUP FORK

GENUINE GEARS AND PARTS

APPLICATION: WARNER TRANSMISSIONS

TRANSMISSION

GENUINE PART NUMBER	DESCRIPTION	GENUINE PART NUMBER	DESCRIPTION
4406-100-001	RAIL	4416-171-004	SHAFT
4406-144-001	SPROCKET	4416-179-001	HUB
4406-144-002	SPROCKET	4416-539-003	COVER ASSY
4406-144-004	SPROCKET	4416-565-002	CASE ASSY
4406-144-005	SPROCKET	4416-589-001	LOCKUP COLLAR ASSY
4406-151-004	TONE WHEEL	4416-622-001	SHAFT ASSY
4406-171-005	SHAFT	4416-625-001	CLUTCH PACK ASSY
4406-171-006	SHAFT-TOD	4416-644-001	SPROCKET ASSY
4406-171-007	MAINSHAFT	4416-648-001	SHIFT MOTOR
4406-171-008	SHAFT	4416-659-002	CARRIER ASSY
4406-410-001	SERVICE KIT	4416-671-002	FRONT O/P SHAFT
4406-565-007	CASE ASSY	4470-143-001	CHAIN
4406-565-008	CASE ASSY-ELECTRIC	4470-171-001	SHAFT LOWER DRIVE
4406-565-009	CASE ASSY	4470-171-002	SPROCKET GEAR
4406-565-021	CASE ASSY ELECTRIC	4470-410-001	CLUTCH KIT-COIL&COLLAR
4406-565-022	CASE ASSY TOD	4470-410-002	KIT-SHAFT,PUMP,HUB
4406-565-024	CASE ASSY MECHANICAL	4470-527-001	BEARING CAP ASSEMBLY
4406-566-002	EXTENSION ASSY	4470-539-001	COVER ASSEMBLY
4406-566-004	EXTENSION ASSY	4470-565-001	CAGE ASSY
4406-566-006	EXTENSION ASSY	4470-596-001	SHIFT FORK ASSEMBLY
4406-566-008	EXTENSION ASSY	4472-171-001	LOWER OUTPUT SHAFT
4406-566-010	EXTENSION ASSY	4472-539-001	COVER ASSEMBLY
4406-596-005	SHIFT FORK	4472-566-001	EXTENSION ASSY
4406-622-001	CAM ASSY	4472-659-003	CARRIER ASSY
4406-622-002	CAM ASSY	4473-625-001	COUPLING ASSY
4406-644-001	SPROCKET ASSY	T86AA-32	BRASS WASHER
4406-648-005	MOTOR ASSY		
4406-648-009	SHIFT MOTOR ASSY		
4406-659-010	CARRIER ASSY		
4406-659-012	PLANETARY ASSY		
4406-712-001	CLUTCH DRUM		
4407-055-001	CLUTCH COLLAR		
4407-089-001	SYN SLEEVE		
4407-096-002	SHIFT FORK		
4407-144-001	SPROCKET GEAR		
4407-162-001	RING GEAR		
4407-171-001	OUTPUT SHAFT		
4407-596-003	SHIFT FORK		
4407-659-002	CARRIER ASSY		
4407-671-002	SHAFT ASSY		
4410-144-002	UPPER SPROCKET		
4410-144-003	SPROCKET GEAR		
4410-162-001	RING GEAR		
4410-539-002	COVER ASSY		
4410-565-001	CASE ASSY		
4410-665-001	SUN GEAR ASSY		
4410-671-002	REAR O/P SHAFT ASSY		
4410-689-001	I/P SHAFT		
4411-122-001	SHIFT SHAFT		
4411-539-002	COVER ASSY		
4411-539-004	COVER ASSY		
4411-565-001	CASE ASSY		
4411-565-002	CASE ASSY		
4411-596-001	SHIFT FORK ASSY		
4411-625-001	CLUTCH PACK		
4411-648-008	MOTOR		
4411-671-001	O/P SHAFT ASSY		
4411-689-003	I/P SHAFT ASSY		
4416-096-001	SHIFT FORK		
4416-147-001	ARMATURE		



REPLACEMENT GEARS AND PARTS

APPLICATION: ALLISON TRANSMISSIONS

NEW★STAR NUMBER	REPLACEMENT FOR PART NUMBER	DESCRIPTION	APPLICATION - MODEL
S-16356	6884900	NEEDLE BEARING ASSEMBLY	AT545
S-16358	23016722	HUB, CONVERTOR	MT683
S-16354	29503064	DRIVE GEAR	AT545
S-16355	29506158	MAINSHAFT	AT540,543,545 LATE
S-16353	29506177	TURBINE SHAFT	AT545
S-16358	29507140	HUB, CONVERTOR	MT683
S-16355	29524363	MAINSHAFT	AT540,543,545 LATE

REPLACEMENT AIR VALVES

APPLICATION: ARVIN MERITOR TRANSMISSIONS

	<p>NEW★STAR NO. S-D971 REPLACEMENT FOR PART NUMBER: A-3280-X-9072</p>		<p>NEW★STAR NO. S-E904 REPLACEMENT FOR PART NUMBER: KIT-5385</p>
---	--	--	---

LATEST ADDITIONS TO OUR CATALOG

EXCEPT WHERE SPECIFIED, ALL PARTS SUPPLIED ARE S&S/NEWSTAR. USE OF OTHER MANUFACTURERS' NAMES, PART NUMBERS, OR TRADEMARKS ARE FOR INFORMATIONAL AND IDENTIFICATION PURPOSES ONLY.

REPLACEMENT GEARS AND PARTS

APPLICATION: ARVIN MERITOR TRANSMISSIONS

TRANSMISSION

NEW STAR NUMBER	REPLACEMENT FOR PART NUMBER	DESCRIPTION	APPLICATION - MODEL
S-12034	5-X-1205	O-RING	9 & 10 SPEEDS, PART OF THE AIR FILTER / REGULATOR
S-13429	42-X-1457	THRUST WASHER	PART OF KIT-5363, 9,10 & 13 SPEED TRANSMISSIONS
S-13430	42-X-1458	THRUST WASHER	PART OF KIT-5363, 9,10 & 13 SPEED TRANSMISSIONS
S-13662	42-X-1459	WASHER-MAINSHAFT	USED IN KIT-5363 MERITOR TRANSMISSIONS
S-A018	1228-G-1203	BEARING	9, 10, 13 SPEED TRANSMISSIONS
S-15318	A-1228-H-1308	OUTPUT BRG ASSY	TRANSMISSION - OUTPUT REAR COVER
S-13502	A-1228-S-1345	BEARING SET	9, 10, 13 SPEED TRANSMISSIONS
S-11983	1229-W-4339	SNAP RING	USED IN KIT-5367 INPUT SHAFT KIT
S-C709	1229-W-4625	SNAP RING	9, 10, 13 SPEED
S-C713	1244-M-2041	SPACER-MAINSHAFT	USED W/KIT-5363, 9/10/13 SPEED TRANSMISSIONS
S-11425	1244-J-2194	SPACER	9, 10 AND 13 SPEEDS
S-11412	2803-C-2759	SHIM	FRONT COUNTERSHAFT BRG
S-11411	2803-C-2837	SHIM	FRONT COUNTERSHAFT BRG
S-11412	2803-R-2826	SHIM .005	FRONT COUNTERSHAFT BRG
S-11413	2803-S-2827	SHIM .008	FRONT COUNTERSHAFT BRG
S-11414	2803-W-2831	SHIM .018	FRONT COUNTERSHAFT BRG
S-12006	3105-K-1155	RETAINER	INPUT SHAFT
S-F361	3107-G-1073	CLUTCH COLLAR	9, 10, 13 SPEED TRANSMISSIONS
S-D971	A-3280-X-9072	FILTER REGULATOR ASSEMBLY*	9 AND 10 SPEEDS
S-15352	3296-H-1126	SHIFT FORK	9, 10, 13 SPEED ALL EXCEPT ELECTRIC OVER AIR (EDA)
S-15353	3296-R-1136	SHIFT FORK	4TH AND 5TH, ALL MERITOR TRANSMISSIONS EXCEPT EDA
S-13798	3296-Q-1161	SHIFT FORK	9, 10, 13 SPEED TRANSMISSIONS
S-11700	3297-N-1366	COUNTERSHAFT	10 SPEED DIRECT DRIVE AND OVERDRIVE "A" & "C" RATIOS
S-13797	3892-S-5011	GEAR-COUNTERSHAFT	9, 10, 13 SPEED
S-11205	3892-W-5015	GEAR-MAINSHAFT	9, 10 AND 13 SPEEDS
S-11644	3892-Y-5017	COUNTERSHAFT GEAR	9 & 10 SPEEDS DIRECT AND 13 SPEED
S-E625	3892-G-5025	M.S. GEAR 60 TEETH	9 SPEED 2ND DIRECT & OVERDRIVE "A" RATIO 10 SPEED 3RD DIRECT & OVERDRIVE "A" RATIO 13 SPEED 2ND OVERDRIVE
S-13855	3892-L-5030	GEAR-MAINSHAFT	9, 10, 13 SPEED TRANSMISSIONS
S-11206	3892-Q-5035	GEAR-COUNTERSHAFT	9, 10 AND 13 SPEEDS
S-10098	3892-M-5135	GEAR-COUNTERSHAFT	MODEL 9B TRANSMISSIONS - 62 TEETH
S-14074	3892-R-5140	GEAR-COUNTERSHAFT	9 SPEED OVERDRIVE - "B" RATIO
S-10148	3892-T-5142	GEAR-COUNTERSHAFT	SERIES 9B TRANSMISSIONS - 73 TOOTH
S-10050	3892-V-5144	MAIN DRIVE GEAR	SERIES 9B TRANSMISSIONS
S-14752	3892-X-5146	GEAR-MAINSHAFT	9 SPEED OVERDRIVE - "B" RATIO
S-14075	3892-Z-5148	MAIN DRIVE GEAR	9 SPEED OVERDRIVE - "B" RATIO
S-11962	3892-H-5156	GEAR-COUNTERSHAFT	9 AND 10 SPEED - OD "A" RATIO
S-11174	3892-K-5159	GEAR COUNTERSHAFT	9 SPEED OVERDRIVE RATIO "A" & 'R'
S-E623	3892-F-5232	M.S. DRIVE GEAR 60 TEETH M.S. 3RD GEAR	10 SPEED OVERDRIVE "A" RATIO 9 SPEED DIRECT 115, 125
S-E624	3892-K-5315	AUX. DRIVE GEAR 38 TEETH USE KIT-5396	9, 10, 13 SPEEDS "A" RATIO
S-E622	3892-L-5316	AUX. DRIVE GEAR 38 TEETH	9, 10, 13 SPEEDS 134, 145, 155 9 AND 10 SPEED RATIOS "A" ONLY
S-15618	3892-A-5331	AUX DRIVE GEAR	9 SPEED - MODELS 134,145,155
S-15513	3892-P-5346	AUX DRIVE GEAR	10 SPEED DIRECT - 135, 145, 155 SERIES
S-11175	3892-M-5395	GEAR-MAINSHAFT	10 SPEED DIR AND OVERDRIVE "A" RATIO
S-11176	3892-N-5396	GEAR-COUNTERSHAFT	10 SPEED DIR AND OVERDRIVE "A" RATIO
S-11173	3892-F-5414	GEAR-MAINSHAFT	10 SPEED OVERDRIVES
S-13987	3892-N-5474	MAIN DRIVE GEAR	9 SPEED OVERDRIVE - "A" & "R" RATIOS
S-14750	3892-Q-5477	GEAR-MAINSHAFT	10 SPEED OVERDRIVE - "C" RATIO
S-13853	3892-S-5479	GEAR-COUNTERSHAFT	10 SPEED OVERDRIVES - "C" RATIO
S-14749	3892-T-5480	GEAR-COUNTERSHAFT	10 SPEED OVERDRIVES - "C" RATIO

LATEST ADDITIONS TO OUR CATALOG

EXCEPT WHERE SPECIFIED, ALL PARTS SUPPLIED ARE S&S/NEWSTAR. USE OF OTHER MANUFACTURERS' NAMES, PART NUMBERS, OR TRADEMARKS ARE FOR INFORMATIONAL AND IDENTIFICATION PURPOSES ONLY.

REPLACEMENT GEARS AND PARTS

APPLICATION: ARVIN MERITOR TRANSMISSIONS

NEW★STAR NUMBER	REPLACEMENT FOR PART NUMBER	DESCRIPTION	APPLICATION - MODEL
S-13986	3892-V-5482	GEAR-COUNTERSHAFT	10 SPEED OVERDRIVES - "C" RATIO
S-13856	3892-E-5517	LOW GEAR	10 SPEED - "A" & "C" RATIOS
S-15322	3892-E-5829	GEAR-MAINSHAFT	10 SPEED - "C" RATIO
S-14751	3892-F-5830	GEAR-MAINSHAFT	10 SPEED OVERDRIVES - "C" RATIO
S-10138	KIT-5250	O-RING KIT	FITS 9 AND 10 SPEED TRANSMISSION
S-11171	KIT-5270	SYNCHRONIZER KIT	9, 10 AND 13 SPEEDS
S-11172	KIT-5289	SYNCHRONIZER KIT	9, 10 AND 13 SPEEDS
S-13460	KIT-5363	MAINSHAFT KIT	10 SPEEDS
S-11410	KIT-5364	SHIM KIT	MAIN COUNTERSHAFT
S-10309	KIT-5367	INPUT SHAFT KIT	9, 10 AND 13 SPEEDS
S-E904	KIT-5385	SLAVE VALVE KIT*	FITS 9, 10 AND 13 SPEED TRANSMISSION
S-A947	KIT-5389	OIL SEAL ASSEMBLY	9 AND 13 SPEEDS
S-11536	KIT-5396	GEAR KIT	9 AND 10 SPEEDS - "A" & "C" RATIOS
S-11537	KIT-5397	AUX DRIVE GEAR KIT	9 AND 10 SPEEDS - "A" RATIOS
S-14706	KIT-5399	GEAR KIT	10 SPEED "C" RATIO
S-15536	KIT-5401	AUX CYLINDER KIT	9, 10 SPEEDS PLATFORM G
S-15514	KIT-5445	SHIFT COVER ASSY	STANDARD O.D. FOR G PLATFORM SERIES
S-15609	KIT-5447	AUX DRIVE GEAR KIT	9, 10, 13 SPEED TRANSMISSIONS
S-13795	KIT-5448	GEAR KIT	9, 10, 13 SPEED TRANSMISSIONS OVERDRIVE

REPLACEMENT COMPONENT PARTS

APPLICATION: CHRYSLER A535 LIGHT DUTY DODGE DAKOTA TRANSMISSIONS

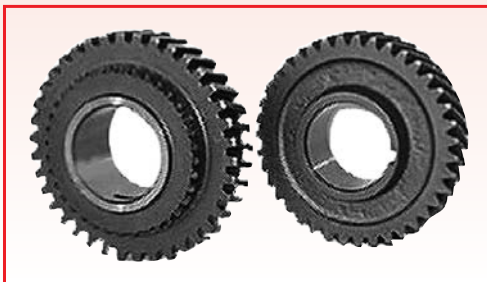

NEW★STAR NUMBER	REPLACEMENT FOR PART NUMBER	DESCRIPTION
S-9054	4338190	INPUT SHAFT
S-9056	4338374	C.S. 5TH GEAR
S-9057	4338375	CLUSTER
S-9884	T535	BEARING AND SEAL KIT

LATEST ADDITIONS TO OUR CATALOG

EXCEPT WHERE SPECIFIED, ALL PARTS SUPPLIED ARE S&S/NEWSTAR. USE OF OTHER MANUFACTURERS' NAMES, PART NUMBERS, OR TRADEMARKS ARE FOR INFORMATIONAL AND IDENTIFICATION PURPOSES ONLY.



REPLACEMENT GEARS AND PARTS

APPLICATION: EATON / FULLER TRANSMISSIONS

TRANSMISSION

NEWSTAR NUMBER	REPLACEMENT FOR PART NUMBER	DESCRIPTION	MODEL APPLICATIONS (ALSO SEE OUR CHART ON THE FOLLOWING PAGE FOR MORE INFORMATION ON SELECT PRODUCT)
S-3103	A-3546	VALVE ASSY	
S-4402	A-3697	KEY & PIN	
S-5027	A-3990	KEY & PIN	
S-3291	A-3991	SLAVE VALVE ASSY	
S-6529	A-4041	AIR FILTER ASSY	MULTIPLE APPLICATIONS
S-4566	A-4091	MAINSHAFT ASSY	
S-14562	A-4096	COUNTERSHAFT	
S-4566	A-4114	MAINSHAFT ASSY	
S-2067	A-4330	COUNTERSHAFT ASSY	
S-5800	A-4335	COUNTERSHAFT ASSY	
S-9276	A-4389	AUX. MAINSHAFT ASSY	
S-2066	A-4413	MAINSHAFT ASSY	
S-4303	A-4414	MAINSHAFT ASSY	
S-9069	A-4421	AUX. COUNTERSHAFT	
S-8011	A-4487	SELECTOR VALVE	
S-8800	A-4490	SELECTOR VALVE	
S-5494	A-4491	SELECTOR VALVE	
S-6531	A-4520	AUX. COUNTERSHAFT ASSY	
S-3291	A-4688	SLAVE VALVE ASSY	
S-C103	A-4723	AUX. COUNTERSHAFT	
S-5295	A-4725	AUX. COUNTERSHAFT	
S-A921	A-4728	AUX. COUNTERSHAFT	
S-4305	A-4736	MAINSHAFT ASSY	
S-4306	A-4738	MAINSHAFT ASSY	
S-9146	A-4740	FILTER/REGULATOR ASSY	
S-7389	A-4819	COUNTERSHAFT ASSY	
S-C461	A-4900	RANGE VALVE - SEE A-6913	
S-13947	A-4918	GEAR ASSEMBLY	
S-5295	A-4957	AUX. COUNTERSHAFT	
S-8030	A-5000	SLAVE VALVE	
S-C462	A-5010	RANGE VALVE - SEE A-6909	
S-C460	A-5015	RANGE VALVE - SEE A-6915	
S-C530	A-5022	INPUT SHAFT	7608LL
S-D404	A-5030	COUNTERSHAFT ASSEMBLY	RT-8609
S-9972	A-5156	AUX. MAINSHAFT	
S-E072	A-5158	COUNTERSHAFT ASSY	
S-11759	A-5159	SHIFT FORK	RT,RT0,RTX11715,14715,15715 RT011708LL,14708LL
S-8821	A-5401	SYNCHRONIZER	FS4005,5005 MID RANGE
S-13175	A-5474	YOKE ASSEMBLY	RT11710,12710,13710,14710,15710,16710
S-14687	A-5692	SYNCHRONIZER	
S-8822	A-5693	SYNCHRONIZER	FS4005,5005,6206 MID RANGE
S-11521	A-5735	AUX COUNTERSHAFT	RT8609,11609,12609,13609
S-11246	A-5882	AUX COUNTERSHAFT	

LATEST ADDITIONS TO OUR CATALOG

EXCEPT WHERE SPECIFIED, ALL PARTS SUPPLIED ARE S&S/NEWSTAR. USE OF OTHER MANUFACTURERS' NAMES, PART NUMBERS, OR TRADEMARKS ARE FOR INFORMATIONAL AND IDENTIFICATION PURPOSES ONLY.

REPLACEMENT GEARS AND PARTS

APPLICATION: EATON / FULLER TRANSMISSIONS

TRANSMISSION

NEWSTAR NUMBER	REPLACEMENT FOR PART NUMBER	DESCRIPTION	MODEL APPLICATIONS (ALSO SEE OUR CHART ON THE FOLLOWING PAGE FOR MORE INFORMATION ON SELECT PRODUCT)
S-D745	A-6137	SYNCHRONIZER	
S-D746	A-6144	SYNCHRONIZER	FS4205A,B,C MID RANGE
S-10443	A-6156	SYNCHRONIZER	
S-13173	A-6163	RANGE YOKE ASSEMBLY	
S-13176	A-6188	YOKE ASSEMBLY	
S-13178	A-6224	FORK & RAIL ASSEMBLY	
S-11427	A-6299	SLEEVE ASSY W/SEAL	RTO,RTOF11707LL,13707MLL,14719MLL,14715,15615
S-15625	A-6340	RETAINER	
S-F232	A-6387	COUNTERSHAFT	RTL013610B,14610B
S-13963	A-6436	AUX COUNTERSHAFT	FR014210,15210,16210C
S-13449	A-6608	SYNCHRONIZER ASSY	
S-13450	A-6609	SYNCHRONIZER ASSY	
S-11245	A-6689	COUNTERSHAFT	
S-F317	A-6756	AUX COUNTERSHAFT	
S-11539	A-6840	AUX COUNTERSHAFT	
S-C462	A-6909	RANGE VALVE-LATE ERGONOMIC DESIGN	REPLACES A5010
S-E467	A-6910	RANGE VALVE-LATE ERGONOMIC DESIGN	REPLACES A5510
S-C461	A-6913	RANGE VALVE-LATE ERGONOMIC DESIGN	REPLACES A4900
S-C460	A-6915	RANGE VALVE-LATE ERGONOMIC DESIGN	REPLACES A5015
S-E648	A-6918	RANGE VALVE-LATE ERGONOMIC DESIGN	REPLACES A5013
S-11203	A-7012	FORK & RAIL ASSEMBLY	
S-E649	A-7313	RANGE VALVE-LATE ERGONOMIC DESIGN	RIGHT HAND DRIVE
S-E650	A-7315	RANGE VALVE-LATE ERGONOMIC DESIGN	RIGHT HAND DRIVE
S-E651	A-7318	RANGE VALVE-LATE ERGONOMIC DESIGN	RIGHT HAND DRIVE
S-6548	G-14534	GEAR	5W43
S-4669	G-15319	GEAR	5W43
S-4661	G-15324	GEAR	5W43
S-2067	K-1013	COUNTERSHAFT	
S-3771	K-1447	O-RING KIT	
S-3772	K-1450	O-RING KIT	
S-3773	K-1451	O-RING KIT	
S-5696	K-1486	AIR FILTER KIT	
S-6517	K-1545	REPL KIT-MAINSHAFT	
S-4308	K-1546	REPL KIT-MAINSHAFT	
S-5743	K-1550	SELECTOR VALVE KIT	
S-8471	K-1553	SELECTOR VALVE KIT	
S-8472	K-1561	SELECTOR VALVE KIT	
S-4405	K-1566	RANGE VALVE KIT	
S-6518	K-1603	GASKET SET	
S-4566	K-1640	MAINSHAFT ASSY	
S-4322	K-1644	REPL KIT-QUILL	
S-7419	K-1650	REPL KIT-DR GEAR	
S-6523	K-1654	SYNCHRONIZER KIT	

LATEST ADDITIONS TO OUR CATALOG

EXCEPT WHERE SPECIFIED, ALL PARTS SUPPLIED ARE S&S/NEWSTAR. USE OF OTHER MANUFACTURERS' NAMES, PART NUMBERS, OR TRADEMARKS ARE FOR INFORMATIONAL AND IDENTIFICATION PURPOSES ONLY.

REPLACEMENT GEARS AND PARTS

APPLICATION: EATON / FULLER TRANSMISSIONS

MODEL APPLICATION

	610	613	910	915	4005	5106	5205	5306	6106	6205	6306	6610	6613	9509	9513	11608	11609	11613	11707	12509	12510	12513	12515	12609	12713	14608	14609	14610	14613	14615	14618	14710	14713	14715	14718	14918	15618	15710	15715	16618	16713	16718	16918	18718	18918	20918			
S-D745								X			X																																						
S-D746																																																	
S-10443								X																																									
S-13173																																X		X								X							
S-13176																											X								X														
S-13178																												X									X					X	X		X				
S-11427																																																	
S-15625																																X																	
S-F232																																																	
S-13963																																																	
S-13449						X	X		X	X																																							
S-13450						X																																											
S-11245																															X		X																
S-F317																										X								X															
S-11539																															X		X																
S-C462																																																	
S-E467																																																	
S-C461																																																	
S-C460																																																	
S-E648																																																	
S-11203																										X								X															
S-E649																																																	
S-E650																																																	
S-E651																																																	
S-6548																																																	
S-4669																																																	
S-4661																																																	
S-2067																	X																																
S-3771																	X																																
S-3772			X	X										X	X																																		
S-3773	X		X											X																																			
S-5696	X	X	X	X											X	X																																	
S-6517			X	X												X																																	
S-4308																																																	
S-5743		X		X													X																																
S-8471	X	X	X	X								X	X	X	X																																		
S-8472	X	X	X	X								X	X	X	X																																		
S-4405	X	X	X	X								X	X	X	X		X																																
S-6518		X	X	X											X	X		X																															
S-4566			X	X											X	X																																	
S-4322	X	X	X	X								X	X	X	X																																		
S-7419																																																	
S-6523			X	X										X	X	X		X																															

LATEST ADDITIONS TO OUR CATALOG

EXCEPT WHERE SPECIFIED, ALL PARTS SUPPLIED ARE S&S/NEWSTAR. USE OF OTHER MANUFACTURERS' NAMES, PART NUMBERS, OR TRADEMARKS ARE FOR INFORMATIONAL AND IDENTIFICATION PURPOSES ONLY.



REPLACEMENT GEARS AND PARTS

APPLICATION: EATON / FULLER TRANSMISSIONS

TRANSMISSION

NEW STAR NUMBER	REPLACEMENT FOR PART NUMBER	DESCRIPTION	MODEL APPLICATIONS (ALSO SEE OUR CHART ON THE FOLLOWING PAGE FOR MORE INFORMATION ON SELECT PRODUCT)
S-6520	K-1670	GEAR KIT-HELIX	
S-9043	K-1698	AIR FILTER /REG. KIT	
S-3307	K-1699	SLAVE VALVE KIT	
S-4406	K-1781	GASKET SET	
S-7559	K-1783	GASKET SET - SEE K-2199	
S-A129	K-1786	REPL KIT-DR GEAR - SEE K-2309	
S-4309	K-1787	REPL KIT-DR GEAR - SEE K-2311	
S-4310	K-1788	REPL KIT-DR GEAR - SEE K-2310	
S-9404	K-1826	RANGE VALVE KIT	
S-6521	K-1833	GEAR KIT-SPLITTER	
S-6522	K-1835	GEAR KIT-SPLITTER	
S-5835	K-1847	REPL KIT-DR GEAR	
S-A880	K-1848	AUX. DRIVE GEAR W/O RINGS	RTOF1258LL
S-9614	K-1850	BEARING & SEAL KIT	
S-9599	K-1851	BEARING & SEAL KIT	
S-9596	K-1856	BEARING & SEAL KIT	906,909,910,913,915,955,958,9508,9509,9513
S-9601	K-1862	BEARING & SEAL KIT	
S-9602	K-1870	BEARING & SEAL KIT	
S-9598	K-1871	BEARING & SEAL KIT	
S-9608	K-1872	BEARING & SEAL KIT	
S-9600	K-1880	BEARING & SEAL KIT	
S-9405	K-1921	RANGE VALVE KIT	
S-9406	K-1922	RANGE VALVE KIT	
S-D419	K-1926	COUNTERSHAFT ASSEMBLY	15615,15715,16915
S-9048	K-1931	GASKET SET	
S-9407	K-1935	SLAVE VALVE KIT	
S-6523	K-1945	SYNCHRONIZER KIT	
S-6524	K-1946	SYNCHRONIZER KIT	
S-6525	K-1947	SYNCHRONIZER KIT	
S-6526	K-1948	SYNCHRONIZER KIT	
S-9649	K-1961	SPLITTER GEAR KIT	RT14613,15613
S-8355	K-1962	SPLITTER GEAR KIT	
S-E772	K-1969	SLEEVE KIT	FOR ALIGNMENT ADAPTER PLATE ON K2424 VALVE KIT
S-13514	K-1972	BEARING & SEAL KIT	14613,14813
S-9600	K-1973	BEARING & SEAL KIT	11608,609,613,615
S-9608	K-1979	BEARING & SEAL KIT	
S-A128	K-2002	O-RING KIT	RTLO14613,7608LL
S-A922	K-2003	PIN AND BUSHING KIT	PART OF S-1607 ISOLATOR - MULTIPLE APPLICATIONS
S-9724	K-2017	SYNCHRONIZER KIT	FS5106,6005,6105 MID RANGE
S-8637	K-2018	GEAR KIT	
S-F102	K-2019	UPDATE KIT	
S-9070	K-2027	SPLITTER GEAR KIT	
S-A781	K-2041	BRG. AND SEAL KIT	FS5106,6206 MID RANGE

LATEST ADDITIONS TO OUR CATALOG

EXCEPT WHERE SPECIFIED, ALL PARTS SUPPLIED ARE S&S/NEWSTAR. USE OF OTHER MANUFACTURERS' NAMES, PART NUMBERS, OR TRADEMARKS ARE FOR INFORMATIONAL AND IDENTIFICATION PURPOSES ONLY.

REPLACEMENT GEARS AND PARTS

APPLICATION: EATON / FULLER TRANSMISSIONS

MODEL APPLICATION

	610	613	910	915	4005	5106	5205	5306	6106	6205	6306	6610	6613	9509	9513	11608	11609	11613	11707	12509	12510	12513	12515	12609	12713	14608	14609	14610	14613	14615	14618	14710	14713	14715	14718	14918	15618	15710	15715	16618	16713	16718	16918	18718	18918	20918									
S-6520	X	X																																																					
S-9043	X	X	X	X								X	X	X	X		X				X	X	X	X			X	X	X	X																									
S-3307	X	X	X	X								X	X	X	X		X				X	X	X	X			X	X	X	X																									
S-4406													X																																										
S-4670			X	X										X	X		X				X	X	X	X			X	X	X	X																									
S-5493																	X										X																												
S-4309			X	X													X										X	X		X																									
S-4310															X																																								
S-9404	X											X		X								X								X																									
S-6521														X																																									
S-6522																						X																																	
S-5835																					X		X																																
S-A880																																																							
S-9614	X										X																																												
S-9599		X											X																																										
S-9596																																																							
S-9601																					X																																		
S-9602																											X	X	X																										
S-9598																																																							
S-9608																											X																												
S-9600																X	X	X																																					
S-9405	X		X	X							X		X		X		X				X	X		X			X	X		X																									
S-9406			X																																																				
S-D419																																																							
S-9048	X										X																																												
S-9407	X	X	X	X							X	X	X	X		X					X	X	X	X			X	X	X	X																									
S-6523		X	X	X								X	X	X	X		X				X	X	X	X			X	X	X	X																									
S-6524		X	X	X								X	X	X	X		X				X	X	X	X			X	X	X	X																									
S-6525			X	X										X	X																																								
S-6526												X					X				X	X	X	X			X	X	X	X																									
S-9649																																																							
S-8355																																																							
S-E772																																																							
S-13514																																																							
S-9600																																																							
S-9608																												X																											
S-A128																																																							
S-A922																																																							
S-9724																																																							
S-8637												X	X																																										
S-F102	X	X										X	X																																										
S-9070															X																																								
S-A781																																																							

LATEST ADDITIONS TO OUR CATALOG

EXCEPT WHERE SPECIFIED, ALL PARTS SUPPLIED ARE S&S/NEWSTAR. USE OF OTHER MANUFACTURERS' NAMES, PART NUMBERS, OR TRADEMARKS ARE FOR INFORMATIONAL AND IDENTIFICATION PURPOSES ONLY.



REPLACEMENT GEARS AND PARTS

APPLICATION: EATON / FULLER TRANSMISSIONS

TRANSMISSION

NEW STAR NUMBER	REPLACEMENT FOR PART NUMBER	DESCRIPTION	MODEL APPLICATIONS (ALSO SEE OUR CHART ON THE FOLLOWING PAGE FOR MORE INFORMATION ON SELECT PRODUCT)
S-A731	K-2054	O-RING KIT	1707LL/DLL,14708LL,14808LL,16908LL
S-A099	K-2061	GASKET SET	MULTIPLE APPLICATIONS
S-8378	K-2110	GASKET SET	
S-9725	K-2113	SYNCHRONIZER KIT	FS4005,5005 MID RANGE
S-A501	K-2114	SYNCHRONIZER KIT	FS4005,5005 MID RANGE
S-A210	K-2170	FILTER REGULATOR KIT	11707,708,715
S-D823	K-2183	SHIM KIT W/SILICONE TUBE	5106,6105,6206,7206 MID RANGE
S-7559	K-2199	GASKET SET	
S-7663	K-2256	OIL SEAL KIT	
S-8474	K-2262	SEAL AND SLINGER KIT	
S-8758	K-2272	MAINSHAFT KIT	
S-D948	K-2277	BEARING & SEAL KIT	
S-D750	K-2284	BEARING & SEAL KIT	11715
S-11446	K-2286	BEARING & SEAL KIT	
S-11447	K-2287	BEARING & SEAL KIT	
S-C043	K-2295	GASKET SET	RTL015610B,16610B,17610B,18610B
S-D933	K-2298	O-RING KIT	RTL0,RTL0F11610B,12610B,13610B,14610B,15610B,16210
S-A129	K-2309	DRIVE GEAR	
S-A586	K-2310	DRIVE GEAR KIT	NEW STYLE FOR K1788
S-A587	K-2311	DRIVE GEAR KIT	NEW STYLE FOR K1787
S-E315	K-2315	AUX. DRIVE GEAR	
S-B439	K-2316	DRIVE GEAR REPAIR KIT	11813,14813,15813
S-D981	K-2327	GASKET SET	RT,RTX11709,12709,13709,14709,16709,11710,12710,13710,14710
S-11837	K-2336	OVERHAUL KIT	14615, 15715, 11707, 11709, 12709, 14709, 16709
S-A923	K-2366	KEY AND WASHER KIT	14718LL,14610A,B,15610B,16610,14710,15710,16710
S-16288	K-2410	SMALL PARTS KIT	9 AND 10 SPEED HEAVY DUTY
S-8336	K-2424	SLAVE VALVE KIT	
S-A924	K-2439	KEY AND WASHER KIT	14608LL,14610,11613/813,12713,14613/813,14713,ETC
S-8333	K-2445	SYNCHRONIZER	
S-8334	K-2446	SYNCHRONIZER	
S-9047	K-2447	SYNCHRONIZER KIT	
S-8602	K-2448	SYNCHRONIZER KIT	
S-9971	K-2468	CLUTCH INST. KIT	
S-E956	K-2640	DRIVE GEAR KIT	RTL013610B,14610B,15610B,16610B
S-F489	K-2773	BEARING & SEAL KIT	RTL014610B,15610B,16610B,17610B,18610B
S-9596	K-2780	BEARING & SEAL KIT	906,909,910,913,915,955,958,9508,9509,9513
S-C708	K-2804	O-RING KIT	
S-10481	K-2805	SHIM KIT	FRO SERIES, RTL016713A,18718,16913A,18918B
S-D658	K-2808	AUX. DRIVE GEAR KIT	
S-11448	K-2865	BEARING & SEAL KIT	
S-14421	K-2867	AUX DRIVE GEAR KIT	
S-F375	K-2918	OIL SEAL KIT	RTO,RT0F11908LL,14908LL,16908LL
S-E294	K-2921	GASKET SET	FRO SUPER 10

LATEST ADDITIONS TO OUR CATALOG

EXCEPT WHERE SPECIFIED, ALL PARTS SUPPLIED ARE S&S/NEWSTAR. USE OF OTHER MANUFACTURERS' NAMES, PART NUMBERS, OR TRADEMARKS ARE FOR INFORMATIONAL AND IDENTIFICATION PURPOSES ONLY.

REPLACEMENT GEARS AND PARTS

APPLICATION: EATON / FULLER TRANSMISSIONS

MODEL APPLICATION

	610	613	910	915	4005	5106	5205	5306	6106	6205	6306	6610	6613	9509	9513	11608	11609	11613	11707	12509	12510	12513	12515	12609	12713	14608	14609	14610	14613	14615	14618	14710	14713	14715	14718	14918	15618	15710	15715	16618	16713	16718	16918	18718	18918	20918									
S-A731																																																							
S-A099																																																							
S-8378		X											X																																										
S-9725																																																							
S-A501																																																							
S-A210																																																							
S-D823																																																							
S-7559			X	X										X	X						X	X	X	X			X	X	X	X																									
S-7663			X										X								X	X	X				X	X	X																										
S-8474																											X	X																											
S-8758				X																																																			
S-D948																															X																								
S-D750																																																							
S-11446																																X																							
S-11447																																																							
S-C043																																																							
S-D933																																																							
S-A129																	X										X																												
S-A586																																																							
S-A587																																																							
S-E315																		X												X																									
S-B439																																																							
S-D981																																																							
S-11837																																																							
S-A923																																																							
S-16288																																																							
S-8336	X	X	X	X								X	X	X	X	X					X	X	X	X			X	X	X	X																									
S-A924																																																							
S-8333		X	X	X									X	X	X	X					X	X	X	X			X	X	X	X																									
S-8334		X	X	X									X	X	X	X					X	X	X	X			X	X	X	X																									
S-9047		X	X	X									X	X	X	X					X	X	X	X			X	X	X	X																									
S-8602		X	X	X									X	X	X	X					X	X	X	X			X	X	X	X																									
S-9971														X	X	X	X				X	X	X	X			X	X	X	X																									
S-E956																																																							
S-F489																																																							
S-9596																																																							
S-C708																											X																												
S-10481																																																							
S-D658																																																							
S-11448																																																							
S-14421																																																							
S-F375																																																							
S-E294																																																							

LATEST ADDITIONS TO OUR CATALOG

EXCEPT WHERE SPECIFIED, ALL PARTS SUPPLIED ARE S&S/NEWSTAR. USE OF OTHER MANUFACTURERS' NAMES, PART NUMBERS, OR TRADEMARKS ARE FOR INFORMATIONAL AND IDENTIFICATION PURPOSES ONLY.



REPLACEMENT GEARS AND PARTS

APPLICATION: EATON / FULLER TRANSMISSIONS

TRANSMISSION

NEWSTAR NUMBER	REPLACEMENT FOR PART NUMBER	DESCRIPTION	MODEL APPLICATIONS (ALSO SEE OUR CHART ON THE FOLLOWING PAGE FOR MORE INFORMATION ON SELECT PRODUCT)
S-11995	K-2923	RANGE PISTON KIT	11210,12210,13210,14210,15210,16210,17210,18210
S-11449	K-2924	BEARING & SEAL KIT	9210 THRU 18210 SERIES W/ ELECTRONIC SPEEDO
S-13709	K-2947	COUNTERSHAFT KIT	
S-11860	K-2958	COUNTERSHAFT KIT	RTX16709B,H,RTL016713
S-10144	K-2960	COUNTERSHAFT KIT	RT1270B,13710B,14710B
S-E336	K-3121	VALVE CONVERSION KIT	LATE GENERATION SPLITTER VALVE KIT
S-C707	K-3122	SPLITTER GEAR KIT	
S-13863	K-3130	FORK ASSEMBLY	FRO11210,12210,13210,14210,15210,16210,17210
S-15477	K-3132	BEARING & SEAL KIT	FRO SERIES - 10 SPEEDS
S-14098	K-3151	UPDATE KIT	
S-E955	K-3189	DRIVE GEAR KIT	
S-F326	K-3202	AUX COUNTERSHAFT	
S-14092	K-3209	IDLER SHAFT KIT	FOR 6, 8, 9, 15, 18 SPEED TRANSMISSIONS
S-F327	K-3220	AUX COUNTERSHAFT	
S-11543	K-3243	GEAR KIT-COUNTERSHAFT	RTL011610B,18610B
S-15335	K-3262	COUNTERSHAFT KIT	FRO & F - 10 SPEED RATIOS
S-16384	K-3264	COUNTERSHAFT KIT	FRO 10 SPEED "C" RATIO
S-12099	K-3286	BEARING & SEAL KIT	18913-T2
S-F233	K-3288	GASKET SET	RTL014913,16713A,16913A,18913A
S-D586	K-3301	GEAR KIT	
S-13255	K-3303	GEAR UPDATE KIT	
S-15612	K-3315	MAINSHAFT KIT	RTL011610B,12610B,13610B,14610B,15610B,16610B
S-10291	K-3331	SPLITTER GEAR KIT	
S-13017	K-3340	BEARING & SEAL KIT	
S-11168	K-3341	O-RING KIT	
S-16576	K-3342	BEARING & SEAL KIT	
S-11450	K-3343	BEARING & SEAL KIT	16913A
S-15365	K-3346	BEARING AND SEAL KIT	
S-A925	K-3376	O-RING KIT	FRO, RTLO SERIES, 13 SPEEDS
S-F459	K-3389	CLUTCH KIT	
S-D754	K-3399	ISOLATOR KIT	REPAIR KIT FOR SHIFT LEVER ISOLATORS
S-14757	K-3419	GEAR UPDATE KIT	FRO-FROF11,12,13,14,15,16210B
S-11491	K-3420	UPDATE KIT	FRO,FR11,12,13,14210C
S-13096	K-3421	SYNCHRONIZER KIT	
S-15282	K-3480	GEAR KIT	
S-11189	K-3495	SYNCHRONIZER KIT	FRO SERIES - 10 SPEEDS
S-C608	K-3497	SYNCHRONIZER KIT	MULTIPLE APPLICATIONS
S-15476	K-3600	CLUTCH INSTALLATION KIT	FRO - 10 SPEED SERIES
S-D743	K-7004	SYNCHRONIZER KIT	
S-D744	K-7005	SYNCHRONIZER KIT	FS4205A,B,C MID RANGE
S-10444	K-7027	SYNCHRONIZER KIT	
S-D470	K-7030	GASKET SET	
S-E593	K-7032	BEARING & SEAL KIT	

LATEST ADDITIONS TO OUR CATALOG

EXCEPT WHERE SPECIFIED, ALL PARTS SUPPLIED ARE S&S/NEWSTAR. USE OF OTHER MANUFACTURERS' NAMES, PART NUMBERS, OR TRADEMARKS ARE FOR INFORMATIONAL AND IDENTIFICATION PURPOSES ONLY.

REPLACEMENT GEARS AND PARTS

APPLICATION: EATON / FULLER TRANSMISSIONS

MODEL APPLICATION

	610	613	910	915	4005	5106	5205	5306	6106	6205	6306	6610	6613	9509	9513	11608	11609	11613	11707	12509	12510	12513	12515	12609	12713	14608	14609	14610	14613	14615	14618	14710	14713	14715	14718	14918	15618	15710	15715	16618	16713	16718	16918	18718	18918	20918						
S-11995																																																				
S-11449																																																				
S-13709																																											X	X	X	X						
S-11860																																																				
S-10144																																																				
S-E336																																																				
S-C707																																					X															
S-13863																																																				
S-15477																																																				
S-14098																																																				
S-E955																																																				
S-F326																																																				
S-14092																																																				
S-F327																																																				
S-11543																																																				
S-15335																																																				
S-16384																																																				
S-12099																																																				
S-F233																																																				
S-D586						X																																														
S-13255						X																																														
S-15612																																																				
S-10291								X																																												
S-13017																																																				
S-11168																																																				
S-16576																																																				
S-11450																																																				
S-15365																																																				
S-A925																																																				
S-F459						X				X																																										
S-D754																																																				
S-14757																																																				
S-11491																																																				
S-13096							X	X		X	X																																									
S-15282																																																				
S-11189																																																				
S-C608																																																				
S-15476																																																				
S-D743							X				X																																									
S-D744																																																				
S-10444								X																																												
S-D470						X																																														
S-E593						X					X																																									

LATEST ADDITIONS TO OUR CATALOG

EXCEPT WHERE SPECIFIED, ALL PARTS SUPPLIED ARE S&S/NEWSTAR. USE OF OTHER MANUFACTURERS' NAMES, PART NUMBERS, OR TRADEMARKS ARE FOR INFORMATIONAL AND IDENTIFICATION PURPOSES ONLY.



REPLACEMENT GEARS AND PARTS

APPLICATION: EATON / FULLER TRANSMISSIONS

TRANSMISSION

NEWSTAR NUMBER	REPLACEMENT FOR PART NUMBER	DESCRIPTION	MODEL APPLICATIONS (ALSO SEE OUR CHART ON THE FOLLOWING PAGE FOR MORE INFORMATION ON SELECT PRODUCT)
S-14103	K-7052	BEARING & SEAL KIT	
S-6507	S-1128	INPUT SHAFT ASSY	
S-6508	S-1130	INPUT SHAFT ASSY	
S-6509	S-1131	INPUT SHAFT ASSY	
S-6510	S-1133	INPUT SHAFT ASSY	
S-2066	S-1150	MAINSHAFT ASSY	
S-6511	S-1252	INPUT SHAFT ASSY	
S-6512	S-1253	INPUT SHAFT ASSY	
S-6513	S-1254	INPUT SHAFT ASSY	
S-6514	S-1255	INPUT SHAFT ASSY	
S-4566	S-1340	MAINSHAFT ASSY	
S-6515	S-1341	MAINSHAFT ASSY	
S-8820	S-1409	INPUT SHAFT ASSY	
S-6516	S-1501	INPUT SHAFT ASSY	
S-A926	S-1607	ISOLATOR ASSY	11707LL,DLL,8608L,13707,6609,8609,8709,11609,12609
S-6519	S-1659	INPUT SHAFT ASSY	
S-A600	S-1661	INPUT SHAFT ASSY	8607,11607,707,605,13707,14607 W/BUSHING
S-9078	S-2120	MAINSHAFT ASSY	
S-16022	S-2129	SHIFT LEVER HOUSING	FRO SERIES - 10 SPEEDS
S-E912	S-2395	INPUT SHAFT	EARLY VERSION FOR SUPER 10-12210,12210,13210,14210
S-11527	S-2560	MAINSHAFT ASSY.	RTLO18918,20918,T2,22918A,A52
S-F024	S-2562	MAINSHAFT ASSY	
S-F234	S-2688	MAINSHAFT ASSY	RTX12710,13710,14710,15710,16710B,C
S-11785	S-2737	MAINSHAFT ASSY	RTLO11610B,12610B,13610B,14610B,15610B,16610B
S-E911	S-2822	INPUT SHAFT ASSY	FOR SUPER 10-15210C,16210C
S-13434	S-2928	INPUT SHAFT ASSY	11609,12609,11615,11715
S-15628	X-1-805	LOCK NUT	MULTIPLE APPLICATIONS
S-15278	X-9-802	LOCK NUT	MULTIPLE APPLICATIONS
S-5753	X12-1202	PLUG	
S-C035	2536	SPRING	SHIFT TOWER - MULTIPLE FULLER APPLICATIONS
S-8534	6074	CLUTCH GEAR	5A43,430,R46
S-5501	8677	BUSHING	
S-2713	8997	NUT	
S-6533	10180	SLEEVE	5W43
S-7390	11956	NUT	
S-7343	12128	NUT	
S-5761	12815	BUSHING (QTY PKG 10).	
S-6536	12845	STREET 1/8"(QTY PKG 10)	
S-15127	12880	BRASS ELBOW	1/8" USED W/SLAVE VALVE PIPING
S-6537	12881	PIPE TEE 1/8"	
S-6539	13977	GEAR	5W43
S-6540	13981	GEAR	5W43
S-6541	13986	CLUTCH	5W43

LATEST ADDITIONS TO OUR CATALOG

EXCEPT WHERE SPECIFIED, ALL PARTS SUPPLIED ARE S&S/NEWSTAR. USE OF OTHER MANUFACTURERS' NAMES, PART NUMBERS, OR TRADEMARKS ARE FOR INFORMATIONAL AND IDENTIFICATION PURPOSES ONLY.

REPLACEMENT GEARS AND PARTS

APPLICATION: EATON / FULLER TRANSMISSIONS

MODEL APPLICATION

	610	613	910	915	4005	5106	5205	5306	6106	6205	6306	6610	6613	9509	9513	11608	11609	11613	11707	12509	12510	12513	12515	12609	12713	14608	14609	14610	14613	14615	14618	14710	14713	14715	14718	14918	15618	15710	15715	16618	16713	16718	16918	18718	18918	20918														
S-14103						X				X																																																		
S-6507																	X				X	X	X	X			X	X	X	X																														
S-6508			X											X	X																																													
S-6509			X	X										X	X																																													
S-6510			X	X										X	X																																													
S-2066			X	X																																																								
S-6511												X	X																																															
S-6512	X											X	X																																															
S-6513												X	X																																															
S-6514												X	X																																															
S-4566			X	X										X	X																																													
S-6515																X				X	X	X					X	X	X																															
S-8820																X				X	X	X	X				X	X	X	X																														
S-6516																X						X	X					X	X	X																														
S-A926																																																												
S-6519																					X	X						X	X	X																														
S-A600																																																												
S-9078																																																												
S-16022																																																												
S-E912																																																												
S-11527																																																												
S-F024																									X										X		X	X							X	X	X													
S-F234																																																												
S-11785																																																												
S-E911																																																												
S-13434																																																												
S-15628																																																												
S-15278																																																												
S-5753									X																																																			
S-C035																																																												
S-8534																																																												
S-5501			X	X										X	X	X	X				X	X	X	X			X	X	X																															
S-2713			X	X										X	X	X	X				X	X	X	X			X	X	X																															
S-6533																																																												
S-7390			X	X										X	X	X	X				X	X	X	X			X	X	X	X																														
S-9164												X																																																
S-5761	X	X	X	X								X	X	X	X	X	X				X	X	X	X			X	X	X	X																														
S-6536	X	X	X	X								X	X	X	X	X	X				X	X	X	X			X	X	X	X																														
S-15127																																																												
S-6537	X	X	X	X								X	X	X	X	X	X				X	X	X	X																																				

REPLACEMENT GEARS AND PARTS

APPLICATION: EATON / FULLER TRANSMISSIONS

TRANSMISSION

NEWSTAR NUMBER	REPLACEMENT FOR PART NUMBER	DESCRIPTION	MODEL APPLICATIONS (ALSO SEE OUR CHART ON THE FOLLOWING PAGE FOR MORE INFORMATION ON SELECT PRODUCT)
S-5746	14267	FRONT BEARING COVER	
S-4345	14273	WASHER	
S-2406	14274	WASHER	
S-2407	14275	WASHER	
S-5867	14276	WASHER	
S-5868	14277	WASHER	
S-2408	14278	WASHER	
S-5870	14279	WASHER	
S-8173	14284	COUNTERSHAFT	
S-F450	14287	BEARING	MULTIPLE APPLICATIONS
S-9115	14289	SNAP RING (QTY PKG 10)	
S-5540	14291	SNAP RING	MULTIPLE APPLICATIONS
S-6542	14303	GEAR-COUNTERSHAFT	
S-8689	14311	GASKET	
S-4595	14317	SNAP RING	
S-6543	14326	AUX.M.S.GEAR	
S-D755	14327	SNAP RING	MULTIPLE APPLICATIONS
S-A691	14330	WASHER	RT9508/9 SPDS 909A THRU 12509
S-9832	14331	SPACER, LOW GEAR	MULTIPLE APPLICATIONS
S-6544	14332	WASHER	
S-8690	14335	GASKET	
S-4366	14337	OIL SEAL	
S-C661	14341	PISTON	RANGE CYLINDER
S-13518	14367	BEARING	MULTIPLE APPLICATIONS
S-5541	14370	FRONT BEARING COVER	
S-1730	14486	GEAR-MAIN DRIVE	
S-1731	14487	GEAR-MAINSHAFT	
S-6545	14488	GEAR-MAINSHAFT	
S-6546	14491	GEAR-MAINSHAFT	
S-14089	14494	CLUTCH RELEASE SHAFT	6, 8 AND 9 SPEED TRANSMISSIONS
S-6547	14519	CLUTCH	5W43
S-4662	14522	COLLAR	5W43
S-8904	14651	VALVE	
S-6549	14654	SLIDING CLUTCH	T905,955
S-6550	14655	GEAR-MAINSHAFT	
S-6551	14656	GEAR-MAINSHAFT	
S-5521	14658	SHIFT BLOCK	
S-6552	14660	INPUT SHAFT	
S-4663	14661	INPUT SHAFT	
S-6553	14709	SLIDING CLUTCH	
S-4156	14711	WASHER	
S-5530	14712	WASHER	
S-5871	14713	WASHER	

LATEST ADDITIONS TO OUR CATALOG

EXCEPT WHERE SPECIFIED, ALL PARTS SUPPLIED ARE S&S/NEWSTAR. USE OF OTHER MANUFACTURERS' NAMES, PART NUMBERS, OR TRADEMARKS ARE FOR INFORMATIONAL AND IDENTIFICATION PURPOSES ONLY.

REPLACEMENT GEARS AND PARTS

APPLICATION: EATON / FULLER TRANSMISSIONS

TRANSMISSION

NEWSTAR NUMBER	REPLACEMENT FOR PART NUMBER	DESCRIPTION	MODEL APPLICATIONS (ALSO SEE OUR CHART ON THE FOLLOWING PAGE FOR MORE INFORMATION ON SELECT PRODUCT)
S-5872	14714	WASHER	
S-5873	14715	WASHER	
S-5874	14716	WASHER	
S-6554	14725	MAIN DRIVE GEAR	
S-5520	14745	MAIN DRIVE GEAR	
S-4157	14749	WASHER	
S-4596	14750	SNAP RING (QTY PKG 10)	
S-6555	14775	MAINSHAFT	5W43
S-6556	14792	MAIN DRIVE GEAR	5W43
S-6558	14886	GEAR-COUNTERSHAFT	
S-2821	14897	SPRING(QTY PACK OF 100)	
S-8691	14918	GASKET	
S-7391	15019	FRONT BEARING COVER	
S-5029	15097	FORK ASSEMBLY	
S-7392	15110	INPUT SHAFT	
S-7393	15111	FRONT BEARING COVER	
S-E918	15260	BEARING	MULTIPLE APPLICATIONS
S-6559	15316	COUNTERSHAFT	5W43
S-6560	15318	COUNTERSHAFT	5W43
S-5612	15385	WASHER	
S-4394	15446	WASHER	
S-3774	15512	VALVE-SEE 19974	
S-6562	15518	GEAR-AUX. DRIVE	
S-5156	15770	SHIFT BLOCK	
S-3856	15918	SPRING-QTY PACK OF 100	
S-5031	15932	WASHER	
S-13946	15953	GEAR-COUNTERSHAFT	MULTIPLE 9 AND 10 SPEED TRANSMISSIONS
S-5925	15959	SLIDING CLUTCH	RTF11615,RTO,RTOF11608LL
S-6563	15972	GEAR	
S-6564	15974	CLUTCH	
S-6565	16001	GEAR-MAIN DRIVE	
S-6566	16002	GEAR-MAINSHAFT	
S-6567	16003	GEAR-COUNTERSHAFT	
S-7394	16021	SLIDING CLUTCH	
S-4567	16118	SLIDING CLUTCH	
S-A879	16131	FORK, LOW & REVERSE	MULTIPLE APPLICATIONS
S-3299	16135	SHIFT YOKE	
S-3298	16136	SHIFT YOKE	
S-7395	16226	SLIDING CLUTCH	
S-6568	16227	GEAR-MAINSHAFT	
S-6569	16228	GEAR-MAINSHAFT	
S-6570	16229	GEAR-MAINSHAFT	
S-6571	16230	GEAR-MAINSHAFT	

LATEST ADDITIONS TO OUR CATALOG

EXCEPT WHERE SPECIFIED, ALL PARTS SUPPLIED ARE S&S/NEWSTAR. USE OF OTHER MANUFACTURERS' NAMES, PART NUMBERS, OR TRADEMARKS ARE FOR INFORMATIONAL AND IDENTIFICATION PURPOSES ONLY.

REPLACEMENT GEARS AND PARTS

APPLICATION: EATON / FULLER TRANSMISSIONS

MODEL APPLICATION

	610	613	910	915	4005	5106	5205	5306	6106	6205	6306	6610	6613	9509	9513	11608	11609	11613	11707	12509	12510	12513	12515	12609	12713	14608	14609	14610	14613	14615	14618	14710	14713	14715	14718	14918	15618	15710	15715	16618	16713	16718	16918	18718	18918	20918			
S-5872																	X			X	X	X	X				X	X	X	X																			
S-5873																	X			X	X	X	X				X	X	X	X																			
S-5874																	X			X	X	X	X				X	X	X	X																			
S-6554																																																	
S-5520																																																	
S-4157																	X			X	X	X	X				X	X	X	X																			
S-4596	X		X	X								X	X	X	X	X	X			X	X	X	X				X	X	X	X																			
S-6555																																																	
S-6556																																																	
S-6558			X	X										X	X																																		
S-2821																	X																																
S-8691			X	X										X	X	X	X			X	X	X	X				X	X	X	X																			
S-7391													X																																				
S-5029		X										X	X																																				
S-7392			X	X										X	X																																		
S-7393			X	X										X	X	X	X			X	X	X	X				X	X	X	X																			
SE918																																																	
S-6559																																																	
S-6560																																																	
S-5612				X												X																																	
S-4394												X	X																																				
S-3774		X											X		X							X								X																			
S-6562			X	X																																													
S-5156			X	X										X	X	X	X			X	X	X	X				X	X	X	X																			
S-3856	X	X	X	X								X	X	X	X	X	X			X	X	X	X				X	X	X	X																			
S-5031																						X		X					X																				
S-13946																																																	
S-5925																																																	
S-6563	X	X																																															
S-6564	X	X																																															
S-6565			X	X																																													
S-6566			X	X																																													
S-6567			X	X																																													
S-7394			X	X										X	X																																		
S-4567																					X	X	X	X				X	X	X	X																		
S-A879																																																	
S-3299																	X				X	X	X					X	X	X																			
S-3298																	X				X	X	X					X	X	X																			
S-7395												X	X																																				
S-6568												X	X																																				
S-6569	X	X																																															
S-6570	X	X																																															
S-6571	X	X																																															

LATEST ADDITIONS TO OUR CATALOG

EXCEPT WHERE SPECIFIED, ALL PARTS SUPPLIED ARE S&S/NEWSTAR. USE OF OTHER MANUFACTURERS' NAMES, PART NUMBERS, OR TRADEMARKS ARE FOR INFORMATIONAL AND IDENTIFICATION PURPOSES ONLY.



REPLACEMENT GEARS AND PARTS

APPLICATION: EATON / FULLER TRANSMISSIONS

TRANSMISSION

NEWSTAR NUMBER	REPLACEMENT FOR PART NUMBER	DESCRIPTION	MODEL APPLICATIONS (ALSO SEE OUR CHART ON THE FOLLOWING PAGE FOR MORE INFORMATION ON SELECT PRODUCT)
S-9140	16236	AUX. DRIVE GEAR	
S-5927	16241	SLIDING CLUTCH	
S-6572	16245	MAINSHAFT	
S-5856	16246	GEAR-MAINSHAFT	
S-9037	16250	GEAR-COUNTERSHAFT	
S-9038	16251	GEAR-COUNTERSHAFT	
S-9039	16252	GEAR-COUNTERSHAFT	
S-9040	16253	GEAR-COUNTERSHAFT	
S-7396	16258	SLIDING CLUTCH	
S-3664	16267	SHIFT YOKE	
S-12027	16288	SPACER	RTL011608,14608,RTL011610B,12610B,13610B,14610B
S-3659	16300	SHIFT YOKE	
S-5875	16310	WASHER	
S-14069	16338	SHIFT FORK	LOW & REV, FITS 15 AND 18 SPEEDS
S-5923	16463	DRIVE GEAR SPACER	
S-7397	16465	INPUT SHAFT	
S-3075	16516	BUSHING QTY PKG 10	
S-15325	16517	SHIFT FORK	15710, 16710
S-5431	16519	GEAR-MAINSHAFT	
S-2192	16566	BUSHING QTY PKG 4	
S-7398	16593	GEAR-MAINSHAFT	
S-D935	16628	SNAP RING	MULTIPLE APPLICATIONS
S-C017	16673	GEAR-MAINSHAFT	
S-5436	16674	GEAR-MAINSHAFT	
S-5430	16675	GEAR-COUNTERSHAFT	
S-7399	16705	GEAR-MAINSHAFT	
S-6573	16706	GEAR-COUNTERSHAFT	
S-7400	16707	GEAR-MAINSHAFT	
S-6574	16708	GEAR-COUNTERSHAFT	
S-7401	16709	GEAR-MAINSHAFT	
S-6575	16710	GEAR-COUNTERSHAFT	
S-2452	16711	GEAR-MAINSHAFT	
S-2453	16713	GEAR-MAINSHAFT	
S-7402	16715	GEAR-AUX. DRIVE	
S-7403	16716	SLIDING CLUTCH	
S-2056	16717	GEAR-MAINSHAFT	
S-7404	16720	GEAR-MAIN DRIVE	
S-7405	16721	GEAR-COUNTERSHAFT	
S-11347	16722	SNAP RING	MULTIPLE APPLICATIONS
S-4597	16723	SNAP RING (QTY PKG 10)	
S-6576	16727	MAIN DRIVE GEAR	
S-5437	16729	GEAR-MAINSHAFT	
S-A466	16733	GEAR-MAINSHAFT	RT9508,RT0958LLB,RT09505B,RT009513

LATEST ADDITIONS TO OUR CATALOG

EXCEPT WHERE SPECIFIED, ALL PARTS SUPPLIED ARE S&S/NEWSTAR. USE OF OTHER MANUFACTURERS' NAMES, PART NUMBERS, OR TRADEMARKS ARE FOR INFORMATIONAL AND IDENTIFICATION PURPOSES ONLY.

REPLACEMENT GEARS AND PARTS

APPLICATION: EATON / FULLER TRANSMISSIONS

MODEL APPLICATION

	610	613	910	915	4005	5106	5205	5306	6106	6205	6306	6610	6613	9509	9513	11608	11609	11613	11707	12509	12510	12513	12515	12609	12713	14608	14609	14610	14613	14615	14618	14710	14713	14715	14718	14918	15618	15710	15715	16618	16713	16718	16918	18718	18918	20918					
S-9140	X																																																		
S-5927													X																																						
S-6572												X																																							
S-5856	X	X																																																	
S-9037		X																																																	
S-9038		X																																																	
S-9039		X																																																	
S-9040		X																																																	
S-7396			X	X											X																																				
S-3664			X	X										X	X																																				
S-12027																X											X		X																						
S-3659	X	X										X	X																																						
S-5875			X	X											X																																				
S-14069																																																			
S-5923																	X				X	X	X	X				X	X	X	X																				
S-7397																	X				X	X	X	X				X	X	X																					
S-3075			X	X											X							X	X	X					X	X	X																				
S-5431																																																			
S-2192	X		X	X										X	X		X			X	X	X	X				X	X	X	X																					
S-7398	X	X	X	X								X	X	X	X					X	X	X	X				X	X	X	X																					
S-D935																																																			
S-C017																					X																														
S-5436																					X	X																													
S-5430																					X	X																													
S-7399															X	X																																			
S-6573															X	X																																			
S-7400															X	X																																			
S-6574															X	X																																			
S-7401															X	X																																			
S-6575															X																																				
S-2452															X	X																																			
S-2453															X	X																																			
S-7402															X																																				
S-7403			X	X											X	X																																			
S-2056															X																																				
S-7404															X	X																																			
S-7405															X	X																																			
S-11347																																																			
S-4597	X	X	X	X								X	X	X	X		X			X	X	X	X				X	X	X	X																					
S-6576															X																																				
S-5437															X																																				
S-A466																																																			

LATEST ADDITIONS TO OUR CATALOG

EXCEPT WHERE SPECIFIED, ALL PARTS SUPPLIED ARE S&S/NEWSTAR. USE OF OTHER MANUFACTURERS' NAMES, PART NUMBERS, OR TRADEMARKS ARE FOR INFORMATIONAL AND IDENTIFICATION PURPOSES ONLY.



REPLACEMENT GEARS AND PARTS

APPLICATION: EATON / FULLER TRANSMISSIONS

TRANSMISSION

NEWSTAR NUMBER	REPLACEMENT FOR PART NUMBER	DESCRIPTION	MODEL APPLICATIONS (ALSO SEE OUR CHART ON THE FOLLOWING PAGE FOR MORE INFORMATION ON SELECT PRODUCT)
S-2022	16743	REGULATOR VALVE	
S-6577	16746	GEAR-MAINSHAFT	
S-6578	16747	GEAR-COUNTERSHAFT	
S-7406	16748	GEAR-MAINSHAFT	
S-7407	16749	GEAR-COUNTERSHAFT	
S-7408	16750	GEAR-MAINSHAFT	
S-4180	16751	GEAR-COUNTERSHAFT	
S-4184	16752	GEAR-MAINSHAFT	
S-7409	16753	GEAR-COUNTERSHAFT	
S-7410	16754	GEAR-MAINSHAFT	
S-7411	16756	GEAR-MAINSHAFT	
S-10344	16757	REV IDLER GEAR	MULTIPLE APPLICATIONS
S-7419	16758	USE 17452	
S-7412	16759	SLIDING CLUTCH	
S-4598	16763	SNAP RING (QTY PKG 10)	
S-3662	16775	SHIFT YOKE - USE 22823	
S-9421	16777	CYLINDER,AUXILIARY	
S-10483	16778	CYLINDER	MULTIPLE APPLICATIONS
S-5790	16805	MAINSHAFT	
S-6579	16809	GEAR-AUX. DRIVE	
S-6580	16811	SLIDING CLUTCH	
S-5342	16815	GEAR-MAINSHAFT	
S-2938	16830	SWITCH	
S-4397	16859	ACTUATOR VALVE	
S-5635	16886	GEAR-MAIN DRIVE	
S-5391	16887	GEAR-COUNTERSHAFT	
S-5636	16888	GEAR-MAINSHAFT	
S-5392	16889	GEAR-COUNTERSHAFT	
S-7413	16941	GEAR-MAINSHAFT	
S-4045	16942	GEAR-COUNTERSHAFT	
S-7414	16943	GEAR-MAINSHAFT	
S-7415	16944	GEAR-COUNTERSHAFT	
S-6581	16945	GEAR-MAINSHAFT	
S-6582	16946	GEAR-COUNTERSHAFT	
S-6583	16947	GEAR-MAINSHAFT	
S-4281	16949	GEAR-MAINSHAFT	
S-9063	16980	SNAP RING	
S-7416	17059	SHIFT FORK	
S-8489	17070	CYLINDER, AUX	
S-8490	17071	CYLINDER	
S-7417	17078	GEAR-AUX. DRIVE	
S-A825	17109	HEX KEY	
S-5395	17121	GEAR-MAIN DRIVE	



REPLACEMENT GEARS AND PARTS

APPLICATION: EATON / FULLER TRANSMISSIONS

MODEL APPLICATION

	610	613	910	915	4005	5106	5205	5306	6106	6205	6306	6610	6613	9509	9513	11608	11609	11613	11707	12509	12510	12513	12515	12609	12713	14608	14609	14610	14613	14615	14618	14710	14713	14715	14718	14918	15618	15710	15715	16618	16713	16718	16918	18718	18918	20918						
S-2022	X	X	X	X								X	X	X	X					X	X	X	X				X	X	X	X																						
S-6577																						X																														
S-6578																						X																														
S-7406																					X	X																														
S-7407																					X	X																														
S-7408																					X	X																														
S-4180																					X	X																														
S-4184																					X	X																														
S-7409																					X	X																														
S-7410																		X			X	X						X		X																						
S-7411																		X			X	X						X		X																						
S-10344																																																				
S-7419																							X																													
S-7412													X				X				X	X	X	X				X	X	X	X																					
S-4598	X	X	X	X								X	X	X	X		X				X	X	X	X				X	X	X	X																					
S-3662				X	X								X	X	X	X		X				X	X	X	X				X	X	X	X	X																			
S-9421				X											X							X	X							X																						
S-10483																																																				
S-5790													X																																							
S-6579													X																																							
S-6580													X																																							
S-5342													X																																							
S-2938	X	X	X	X								X	X	X	X						X	X	X	X				X	X	X	X																					
S-4397	X	X										X	X					X																																		
S-5635														X																																						
S-5391														X																																						
S-5636														X																																						
S-5392														X																																						
S-7413																						X	X																													
S-4045																						X	X																													
S-7414																						X	X																													
S-7415																						X	X																													
S-6581																						X	X																													
S-6582																						X	X																													
S-6583																						X	X																													
S-4281																						X	X						X		X																					
S-9063																							X	X						X	X	X																				
S-7416																	X														X																					
S-8489															X	X							X																													
S-8490															X								X																													
S-7417			X	X										X																																						
S-A825																	X				X	X	X					X	X	X																						
S-5395																						X	X																													

EXCEPT WHERE SPECIFIED, ALL PARTS SUPPLIED ARE S&S/NEWSTAR. USE OF OTHER MANUFACTURERS' NAMES, PART NUMBERS, OR TRADEMARKS ARE FOR INFORMATIONAL AND IDENTIFICATION PURPOSES ONLY.



REPLACEMENT GEARS AND PARTS

APPLICATION: EATON / FULLER TRANSMISSIONS

TRANSMISSION

NEWSTAR NUMBER	REPLACEMENT FOR PART NUMBER	DESCRIPTION	MODEL APPLICATIONS (ALSO SEE OUR CHART ON THE FOLLOWING PAGE FOR MORE INFORMATION ON SELECT PRODUCT)
S-5396	17122	GEAR-COUNTERSHAFT	
S-5835	17214	REPL KIT-DR GEAR - SEE K-1847	
S-5397	17217	GEAR-MAINSHAFT	
S-5398	17242	SLIDING CLUTCH	
S-5399	17247	GEAR-MAINSHAFT	
S-5533	17248	WASHER	
S-5876	17255	WASHER	
S-5877	17256	WASHER	
S-5878	17257	WASHER	
S-5879	17258	WASHER	
S-9424	17259	WASHER	
S-9425	17260	WASHER	
S-7419	17452	GEAR-USE K-1650	
S-A164	17453	O-RING QTY. PACK OF 2	K1786,K1787,K1788,K2309,K2310,K2311 DRIVE GEAR KITS
S-2206	17568	GEAR-MAIN DRIVE	
S-7420	17569	GEAR-COUNTERSHAFT	
S-8381	17694	LEVER	
S-5926	17894	AUX. DRIVE GEAR	RTF1110
S-6584	17910	SLIDING CLUTCH	
S-6585	17911	COUPLER-MAINSHAFT	
S-6586	17912	SLIDING CLUTCH	
S-7421	17913	SLIDING CLUTCH	
S-4565	17914	COUPLER-MAINSHAFT	
S-5749	18019	AUX. M.S. WASHER	
S-E323	18128	DOWEL PIN REAR CASE	MULTIPLE APPLICATIONS
S-2055	18192	COUPLER-MAINSHAFT	
S-2054	18193	COUPLER-MAINSHAFT	
S-4586	18250	WASHER	
S-4587	18251	WASHER	
S-9074	18387	INPUT SHAFT	
S-6587	18438	GEAR-MAIN DRIVE	
S-4839	18439	SLIDING CLUTCH	
S-6588	18440	GEAR-MAINSHAFT	
S-6514	18446	INPUT SHAFT ASSY - SEE S-1255	
S-5438	18448	GEAR-MAIN DRIVE	
S-6589	18449	GEAR-MAINSHAFT	
S-13267	18520	GEAR-MAINSHAFT	RT012509,RT1258LL
S-6590	18665	MAINSHAFT	
S-6591	18666	MAINSHAFT	
S-6592	18667	GEAR-AUX. DRIVE	
S-5633	18725	GEAR-AUX. DRIVE	
S-A927	18922	SHIFT FORK	
S-7423	18994	GEAR-MAINSHAFT	



REPLACEMENT GEARS AND PARTS

APPLICATION: EATON / FULLER TRANSMISSIONS

MODEL APPLICATION

	610	613	910	915	4005	5106	5205	5306	6106	6205	6306	6610	6613	9509	9513	11608	11609	11613	11707	12509	12510	12513	12515	12609	12713	14608	14609	14610	14613	14615	14618	14710	14713	14715	14718	14918	15618	15710	15715	16618	16713	16718	16918	18718	18918	20918					
S-5396																					X	X																													
S-5835																						X	X																												
S-5397																						X	X																												
S-5398																						X	X					X		X																					
S-5399																						X	X																												
S-5533																						X	X					X		X																					
S-5876																X																																			
S-5877															X																																				
S-5878																					X	X	X				X	X	X																						
S-5879																				X	X	X				X	X	X																							
S-9424												X																																							
S-9425												X																																							
S-7419																						X																													
S-A164																																																			
S-2206																				X	X	X	X																												
S-7420																				X	X	X	X																												
S-8381	X	X	X	X								X	X	X	X		X			X	X	X	X			X	X	X	X																						
S-5926																																																			
S-6584																X																																			
S-6585															X																																				
S-6586																					X																														
S-7421																					X																														
S-4565																					X																														
S-5749																					X																														
S-E323																																																			
S-2055			X													X																																			
S-2054																				X	X	X					X		X																						
S-4586			X	X												X																																			
S-4587																					X																														
S-9074																X																																			
S-6587	X																																																		
S-4839	X										X						X																																		
S-6588	X																																																		
S-6514												X	X																																						
S-5438	X	X																																																	
S-6589	X	X																																																	
S-13267																																																			
S-6590												X																																							
S-6591												X																																							
S-6592	X											X																																							
S-5633				X									X														X																								
S-A927																									X																										
S-7423															X							X																													



REPLACEMENT GEARS AND PARTS

APPLICATION: EATON / FULLER TRANSMISSIONS

TRANSMISSION

NEW STAR NUMBER	REPLACEMENT FOR PART NUMBER	DESCRIPTION	MODEL APPLICATIONS (ALSO SEE OUR CHART ON THE FOLLOWING PAGE FOR MORE INFORMATION ON SELECT PRODUCT)
S-6593	18995	SLIDING CLUTCH	
S-7424	18996	SLIDING CLUTCH	
S-11758	19063	SHIFT BLOCK - 9 & 10 SPEED HEAVY DUTY	
S-A928	19110	OIL SEAL	
S-4375	19128	SHIFT YOKE	
S-5432	19129	COUPLER-MAINSHAFT	
S-4282	19131	COUPLER-MAINSHAFT	
S-7425	19132	SLIDING CLUTCH	
S-8715	19165	GEAR-MAINSHAFT	
S-A700	19203	SPACER	
S-5699	19205	GEAR-MAINSHAFT	
S-5535	19206	GEAR-MAINSHAFT	
S-5700	19207	GEAR-MAINSHAFT	
S-5539	19209	COUNTERSHAFT	
S-5538	19210	GEAR-COUNTERSHAFT	
S-4885	19220	GEAR-MAINSHAFT	
S-A088	19221	GEAR-MAINSHAFT	
S-6601	19223	GEAR-MAINSHAFT - USE 20388	
S-7883	19238	GEAR-COUNTERSHAFT - USE 4305069	
S-5519	19240	GEAR-COUNTERSHAFT - USE 21020	
S-5518	19241	GEAR-MAIN DRIVE - USE 21021	
S-7226	19242	GEAR-MAINSHAFT - USE 20391	
S-7227	19243	GEAR-COUNTERSHAFT - USE 20392	
S-7224	19246	GEAR-MAINSHAFT - USE 20389	
S-6602	19247	GEAR-COUNTERSHAFT - USE 20471	
S-A129	19254	USE K-2309	
S-6599	19268	GEAR-MAINSHAFT - USE 20381	
S-4309	19275	USE K-1787	
S-9141	19277	GEAR-MAINSHAFT	
S-C296	19281	AUX. MAINSHAFT	RT8608L,11609A,11610,11608,RT011609A,B,11610,ETC
S-5536	19294	MAIN DRIVE GEAR	
S-5537	19296	GEAR-COUNTERSHAFT	
S-13289	19300	GEAR-COUNTERSHAFT	
S-A261	19305	AUX. DRIVE GEAR	6609,6610,8609 MID RANGE
S-A780	19315	GEAR-MAINSHAFT	11608LL,11615
S-8030	19470	SLAVE VALVE - USE A-5000	
S-C439	19549	COUNTERSHAFT	RT0,RTX11509,12509,13609,RT,RT0,RTX11709,12709,ETC
S-A692	19554	GEAR-COUNTERSHAFT	RT0,RTX1110,12510
S-A929	19612	GEAR-MAINSHAFT	RT0,RT0F11607L,11707LL,DLL,T11605A,B,TO11605C
S-7225	19614	USE 20390	
S-7426	19615	GEAR-COUNTERSHAFT	
S-9114	19622	GEAR-MAINSHAFT	
S-7885	19628	GEAR-MAINSHAFT - USE 21024	

LATEST ADDITIONS TO OUR CATALOG

EXCEPT WHERE SPECIFIED, ALL PARTS SUPPLIED ARE S&S/NEWSTAR. USE OF OTHER MANUFACTURERS' NAMES, PART NUMBERS, OR TRADEMARKS ARE FOR INFORMATIONAL AND IDENTIFICATION PURPOSES ONLY.

REPLACEMENT GEARS AND PARTS

APPLICATION: EATON / FULLER TRANSMISSIONS

TRANSMISSION

NEWSTAR NUMBER	REPLACEMENT FOR PART NUMBER	DESCRIPTION	MODEL APPLICATIONS (ALSO SEE OUR CHART ON THE FOLLOWING PAGE FOR MORE INFORMATION ON SELECT PRODUCT)
S-4297	19632	GEAR-MAINSHAFT	
S-4298	19633	GEAR-COUNTERSHAFT	
S-7887	19638	GEAR-MAINSHAFT - USE 21261	
S-7888	19639	GEAR-COUNTERSHAFT - USE 21262	
S-5930	19643	GEAR-COUNTERSHAFT - USE 20461	
S-6598	19644	GEAR-MAINSHAFT - USE 20377	
S-A586	19661	USE K-2310	
S-E325	19663	GEAR-MAINSHAFT - USE 20917	
S-9676	19667	GEAR-MAINSHAFT, AUX.	
S-6594	19726	GEAR-MAINSHAFT	
S-6595	19783	GEAR-MAINSHAFT	
S-5435	19784	SLIDING CLUTCH	
S-8687	19870	GASKET	
S-3774	19974	SPLITTER VALVE	
S-5434	20022	AUX. M.S. GEAR	
S-6596	20024	AUX. M.S. GEAR	
S-F231	20191	SPEEDO ROTOR	RTO,RTOF11707DLL,13707DLL,14608LL
S-4788	20323	SLIDING CLUTCH	
S-6597	20336	SLIDING CLUTCH	
S-5835	20350	USE K-1847	
S-6598	20377	GEAR-MAINSHAFT	
S-4301	20378	GEAR-COUNTERSHAFT	
S-5928	20379	GEAR-MAINSHAFT	
S-5929	20380	GEAR-COUNTERSHAFT	
S-6599	20381	GEAR-MAINSHAFT	
S-6600	20382	GEAR-COUNTERSHAFT	
S-7223	20383	GEAR-MAINSHAFT	
S-6601	20388	GEAR-MAINSHAFT	
S-7224	20389	GEAR-MAINSHAFT	
S-7225	20390	GEAR-MAINSHAFT	
S-7226	20391	GEAR-MAINSHAFT	
S-7227	20392	GEAR-COUNTERSHAFT	
S-9001	20450	SHIFT FORK	MULTIPLE APPLICATIONS
S-7228	20458	GEAR-MAIN DRIVE	
S-7229	20459	GEAR-COUNTERSHAFT	
S-4230	20460	GEAR-MAIN DRIVE	
S-5930	20461	GEAR-COUNTERSHAFT	
S-6602	20471	GEAR-COUNTERSHAFT	
S-4298	20481	GEAR-COUNTERSHAFT	
S-9670	20490	ACTUATING PIN	
S-7231	20535	INPUT SHAFT	
S-4312	20550	RETAINER	
S-D736	20561	AUX DRIVE GEAR	AUX MAINSHAFT CONVERSION GEAR, 9 TO 13 SPEEDS



REPLACEMENT GEARS AND PARTS

APPLICATION: EATON / FULLER TRANSMISSIONS

MODEL APPLICATION

	610	613	910	915	4005	5106	5205	5306	6106	6205	6306	6610	6613	9509	9513	11608	11609	11613	11707	12509	12510	12513	12515	12609	12713	14608	14609	14610	14613	14615	14618	14710	14713	14715	14718	14918	15618	15710	15715	16618	16713	16718	16918	18718	18918	20918						
S-4297																	X										X	X		X																						
S-4298																	X										X	X		X																						
S-7887																	X																																			
S-7888																	X																																			
S-5930																													X		X																					
S-6598																													X		X																					
S-4310																															X																					
S-7814																														X																						
S-9676																											X	X																								
S-6594			X	X											X																																					
S-6595																				X		X																														
S-5435																X																																				
S-8687			X	X											X	X	X				X	X	X	X			X	X	X	X																						
S-3774	X											X			X							X								X																						
S-5434				X																																																
S-6596																																																				
S-F231																																																				
S-4788																	X			X	X	X	X				X	X	X	X																						
S-6597													X															X	X	X	X																					
S-5835																				X		X																														
S-6598																												X		X																						
S-4301																												X		X																						
S-5928																												X		X																						
S-5929																												X		X																						
S-6599	X																					X																														
S-6600																												X		X																						
S-7223																												X		X																						
S-6601																																																				
S-7224																	X											X																								
S-7225																												X		X																						
S-7226																												X		X																						
S-7227																													X		X																					
S-9001																																																				
S-7228	X																X											X																								
S-7229	X																X											X																								
S-4230	X																											X																								
S-5930	X																											X																								
S-6602																	X																																			
S-4298																	X											X	X		X																					
S-9670	X	X	X	X								X	X	X	X	X	X				X	X	X	X			X	X	X	X																						
S-7231																							X	X					X	X	X																					
S-4312																	X																																			
S-D736																	X																																			

REPLACEMENT GEARS AND PARTS

APPLICATION: EATON / FULLER TRANSMISSIONS

TRANSMISSION

NEWSTAR NUMBER	REPLACEMENT FOR PART NUMBER	DESCRIPTION	MODEL APPLICATIONS (ALSO SEE OUR CHART ON THE FOLLOWING PAGE FOR MORE INFORMATION ON SELECT PRODUCT)
S-13922	20583	COUNTERSHAFT GEAR	RT7608LL, 8609
S-D405	20593	GEAR-MAINSHAFT	7608LL,8609
S-D420	20614	MAINSHAFT	
S-D406	20615	SLIDING CLUTCH	7608LL,8609
S-F259	20619	SPACER-MAINSHAFT	7608LL,RT8609
S-D934	20635	O-RING	RT7608LL,RT8609
S-A331	20661	GEAR-MAINSHAFT	
S-A332	20662	GEAR-COUNTERSHAFT	
S-A333	20663	GEAR-MAINSHAFT	
S-A334	20664	GEAR-COUNTERSHAFT	
S-A335	20665	GEAR-MAINSHAFT	
S-A336	20666	GEAR-COUNTERSHAFT	
S-E330	20822	GASKET	
S-D407	20833	GEAR-MAINSHAFT	7608LL,8609
S-C441	20840	PTO GEAR, COUNTERSHAFT	MULTIPLE FULLER APPLICATIONS
S-E325	20917	GEAR-MAINSHAFT	RT00,RT011613,14613,RT015613
S-10484	20932	GEAR-MAINSHAFT, AUX.	
S-7883	21018	GEAR-COUNTERSHAFT	
S-7884	21019	MAIN DRIVE GEAR	
S-5519	21020	GEAR-COUNTERSHAFT	
S-5518	21021	GEAR-MAIN DRIVE	
S-7885	21024	GEAR-MAINSHAFT	
S-7886	21025	GEAR-COUNTERSHAFT	
S-4528	21036	OIL SEAL	
S-A642	21074	INPUT SHAFT	
S-7887	21261	GEAR-MAINSHAFT	
S-7888	21262	GEAR-COUNTERSHAFT	
S-9114	21263	GEAR-MAINSHAFT	
S-9098	21264	GEAR-COUNTERSHAFT	
S-9142	21319	GEAR-AUX. RED M.S.	11715,14715,15715
S-9629	21320	SNAP RING RETAINER	
S-A736	21321	GEAR-AUX. DRIVE	11715,14715,15715
S-9144	21322	GEAR-AUX. DRIVE	11708,14708
S-9277	21325	AUX. MAINSHAFT	
S-A672	21342	SPACER	
S-A885	21350	WASHER,AUX. M.S.	RTXL14715,15715,RT0,RT0F13770DLL,MLL,14709MLL
S-11760	21353	WASHER-MAINSHAFT	RT,RT011715,RT011708LL
S-A693	21354	WASHER	RTL011707LL,13707DLL,MLL
S-C024	21355	BEARING	11709,11710,11715,12709,12710,12713,13709,13710
S-C025	21356	BEARING	11707,11708,14708,14709,14710,14713,14715,14718,ETC
S-9674	21360	SLIDING CLUTCH	
S-9387	21361	GEAR-MAINSHAFT	
S-9285	21496	GEAR-MAINSHAFT	

LATEST ADDITIONS TO OUR CATALOG

EXCEPT WHERE SPECIFIED, ALL PARTS SUPPLIED ARE S&S/NEWSTAR. USE OF OTHER MANUFACTURERS' NAMES, PART NUMBERS, OR TRADEMARKS ARE FOR INFORMATIONAL AND IDENTIFICATION PURPOSES ONLY.

REPLACEMENT GEARS AND PARTS

APPLICATION: EATON / FULLER TRANSMISSIONS

MODEL APPLICATION

	610	613	910	915	4005	5106	5205	5306	6106	6205	6306	6610	6613	9509	9513	11608	11609	11613	11707	12509	12510	12513	12515	12609	12713	14608	14609	14610	14613	14615	14618	14710	14713	14715	14718	14918	15618	15710	15715	16618	16713	16718	16918	18718	18918	20918					
S-13922																																																			
S-D405																																																			
S-D420																																																			
S-D406																																																			
S-F259																																																			
S-D934																																																			
S-A331									X																																										
S-A332									X																																										
S-A333									X																																										
S-A334									X																																										
S-A335									X																																										
S-A336									X																																										
S-E330		X	X												X	X	X				X	X	X	X			X	X	X	X																					
S-D407																																																			
S-C441																																																			
S-E325																																																			
S-10484																								X																											
S-7883				X													X											X																							
S-7884																	X											X																							
S-5519			X														X											X																							
S-5518				X													X											X																							
S-7885																	X																																		
S-7886																	X																																		
S-4528		X	X									X		X			X					X	X							X																					
S-A642									X																																										
S-7887																	X																																		
S-7888																	X																																		
S-9114																												X		X																					
S-9098																												X		X																					
S-9142																																																			
S-9629																																																			
S-A736																																																			
S-9144																																																			
S-9277																																																			
S-A672																																																			
S-A885																																																			
S-11760																																																			
S-A693																																																			
S-C024																																																			
S-C025																																																			
S-9674																																																			
S-9387																																																			
S-9285																	X											X																							

LATEST ADDITIONS TO OUR CATALOG

EXCEPT WHERE SPECIFIED, ALL PARTS SUPPLIED ARE S&S/NEWSTAR. USE OF OTHER MANUFACTURERS' NAMES, PART NUMBERS, OR TRADEMARKS ARE FOR INFORMATIONAL AND IDENTIFICATION PURPOSES ONLY.



REPLACEMENT GEARS AND PARTS

APPLICATION: EATON / FULLER TRANSMISSIONS

TRANSMISSION

NEW STAR NUMBER	REPLACEMENT FOR PART NUMBER	DESCRIPTION	MODEL APPLICATIONS (ALSO SEE OUR CHART ON THE FOLLOWING PAGE FOR MORE INFORMATION ON SELECT PRODUCT)
S-9286	21497	GEAR-COUNTERSHAFT	11609P,13609P,14609P
S-9287	21498	GEAR-MAINSHAFT	RTX,RTXF11609A,B,P,12609P,13690B,14609P
S-9288	21499	GEAR-COUNTERSHAFT	11609P,12609P,13609P,14609P
S-7410	21502	GEAR-MAINSHAFT - USE 16754	RTX16709B,H
S-11993	21545	GEAR-MAINSHAFT	
S-A805	21546	GEAR-MAINSHAFT	FS4005,CL450 MID RANGE
S-A877	21586	GEAR-COUNTERSHAFT	RTO,RTOF15618,RTLO/RTLOF13610B,14610A,B,14618
S-C016	21587	GEAR-MAINSHAFT	
S-A878	21588	GEAR-COUNTERSHAFT	RTO,RTOF15618,RTLO/RTLOF16618,14618,14623B
S-A694	21589	GEAR-MAINSHAFT	
S-11346	21590	GEAR-COUNTERSHAFT	
S-A695	21591	GEAR-MAINSHAFT	
S-13269	21609	CYLINDER ASSY.	RTL,RTLO - 10,13,15 SPEEDS
S-7906	21661	GEAR-MAINDRIVE	
S-7912	21662	SLIDING CLUTCH	
S-7907	21663	GEAR-MAINSHAFT	
S-7910	21664	WASHER	
S-7911	21665	WASHER	
S-B282	21669	GEAR-MAINSHAFT	
S-B283	21670	GEAR-MAINSHAFT OVERDRIVE	
S-F383	21671	MAIN DRIVE GEAR	RT8609
S-C531	21672	GEAR-MAINSHAFT	7608LL,RT8609
S-A930	21898	INPUT SHAFT	
S-B247	21918	LO GEAR	
S-A931	21930	SLIDING CLUTCH	RTLO,RTLOF11610B,12610B,13610B,14610A,B,14618
S-B248	21931	GEAR-AUX. MAINSHAFT	
S-A796	21937	NUT	
S-9290	22025	GEAR-MAIN DRIVE	14715,15615
S-D411	22026	SLIDING CLUTCH - USE 4304317	12713,14713,16713,11708,709
S-9423	22027	GEAR-MAINSHAFT	
S-9099	22028	GEAR-MAIN DRIVE	11608,708,719,14608
S-9522	22032	WASHER	RTO,RTX12609,14609,11709,12709,14709,ETC
S-E946	22075	GEAR-MAINSHAFT	
S-7878	22079	M.S. 4TH GEAR	FS4005A,B MID RANGE
S-7881	22080	C.S. 4TH GEAR	FS4005A,B MID RANGE
S-6603	22254	NUT	
S-D408	22371	AUX. DRIVE GEAR	7608LL
S-A337	22395	GEAR-MAINSHAFT	
S-C532	22743	GEAR-MAINSHAFT	
S-F026	22744	GEAR-COUNTERSHAFT	RTX13609A,B
S-D427	22774	GEAR-MAINSHAFT	RT13609,14609P,R
S-13704	22823	SHIFT FORK	REPLACES 16775 - MULTIPLE APPLICATIONS
S-F035	22899	WASHER	11709,12709,13709,14709,16709,11710,12710,13710

REPLACEMENT GEARS AND PARTS

APPLICATION: EATON / FULLER TRANSMISSIONS

TRANSMISSION

NEWSTAR NUMBER	REPLACEMENT FOR PART NUMBER	DESCRIPTION	MODEL APPLICATIONS (ALSO SEE OUR CHART ON THE FOLLOWING PAGE FOR MORE INFORMATION ON SELECT PRODUCT)
S-13827	22903	SPACER	RTL011709,11710,12709,12710,13709,13710,14709
S-11519	22915	SLIDING CLUTCH	RTLO,RTLOF14610A,RT014109B-AT,11109A-AT,ATE
S-2938	22940	SWITCH	MULTIPLE APPLICATIONS
S-9798	22959	MAIN DRIVE GEAR - USE 22961	MULTIPLE APPLICATIONS
S-9798	22961	MAIN DRIVE GEAR	MULTIPLE APPLICATIONS
S-13420	22969	SPEEDO SPACER	RT,RT014709,RTX16709,15710,16710
S-C533	23018	GEAR-MAINSHAFT	RTX13609
S-A296	23102	GEAR-MAINSHAFT	MULTIPLE APPLICATIONS
S-F016	23139	SLIDING CLUTCH	RT013707DLL,MLL
S-A736	23159	AUX. DRIVE GEAR	RT,RTX13709H,13710B,C,14710B,C,15710C,16710B,C
S-F422	23160	GEAR-COUNTERSHAFT	RT13709
S-F079	23301	MAINSHAFT	
S-9952	23566	INPUT SHAFT	
S-A338	23569	INPUT SHAFT	8607,11607,707,605,13707,14607
S-A826	23605	BREATHER	NEW NUMBER 4304602
S-F359	23653	GEAR,REVERSE	RT0,RTX11709B,12709B,14709B,16709B
S-8498	23694	HUB GEAR	
S-8499	23695	MAINSHAFT	
S-10279	23696	MAINSHAFT	FS5005A,B,C MIDRANGE
S-6604	55506	HOSE ASSY-18"	
S-6605	55507	HOSE ASSY-20"	
S-6606	55508	HOSE ASSY-30"	
S-6607	55509	HOSE ASSY-34"	14708,16618
S-6608	55516	HOSE ASSY-22"	
S-6609	55518	HOSE ASSY-32"	
S-6610	55522	HOSE ASSY-28"	
S-5788	55523	HOSE ASSY-29"	
S-4400	55524	HOSE ASSY-27"	
S-6611	55525	HOSE ASSY-17"	
S-6612	55526	HOSE ASSY-26"	
S-6613	55527	HOSE ASSY-15"	
S-C125	55528	HOSE ASSY-36	RTL012913,14913,18913,16913,14918,16918,18718,ETC
S-6614	83001	SLEEVE QTY PKG 100	
S-A155	83002	SLEEVE QTY PKG 100	
S-8026	83501	BRASS NUT 1/8" QTY PKG 25	
S-6615	84001	CONNECTOR QTY PKG 10	
S-4401	84002	CONNECTOR QTY PKG 10	
S-9685	84003	FITTING-QTY PKG 10	
S-E037	84004	CONNECTOR	5/32" TUBE X 1/8"
S-9686	84005	CONNECTOR-PUSH TO CONNECT	5/32" TUBE X 1/16"
S-D912	84006	CONNECTOR-PUSH TO CONNECT	5/32" TUBE X 1/8"
S-6616	84101	CONNECTOR-QTY PKG 10	
S-9687	84102	FITTING-QTY PKG 10	

LATEST ADDITIONS TO OUR CATALOG

EXCEPT WHERE SPECIFIED, ALL PARTS SUPPLIED ARE S&S/NEWSTAR. USE OF OTHER MANUFACTURERS' NAMES, PART NUMBERS, OR TRADEMARKS ARE FOR INFORMATIONAL AND IDENTIFICATION PURPOSES ONLY.

REPLACEMENT GEARS AND PARTS

APPLICATION: EATON / FULLER TRANSMISSIONS

TRANSMISSION

NEWSTAR NUMBER	REPLACEMENT FOR PART NUMBER	DESCRIPTION	MODEL APPLICATIONS (ALSO SEE OUR CHART ON THE FOLLOWING PAGE FOR MORE INFORMATION ON SELECT PRODUCT)
S-9688	85001	FITTING-QTY PKG 10	
S-6617	85002	ELBOW ASSY-QTY PKG 10	
S-D969	85003	ELBOW-PUSH TO CONNECT	5/32" TUBE X 1/8"
S-5753	X-12-1202	MAGNETIC PLUG	
S-9752	X-14-800	1/2" CHROME BALL-QTY PKG 50	
S-7880	3315536	INPUT SHAFT	
S-B020	3315679	PLUG	FS5205A,5306A,6205A,6305A,6306A MID RANGE
S-A932	3315715	GEAR-MAINSHAFT	FS5106A,6206A MID RANGE
S-A933	3315720	GEAR-MAINSHAFT	FS5106A,6206A MID RANGE
S-11426	3315743	GEAR-COUNTERSHAFT	FS6406A MID RANGE
S-11850	3315857	INPUT SHAFT	
S-A934	3316257	INPUT SHAFT	FS5106A,6206A MID RANGE
S-12028	3316313	FRONT BEARING COVER	
S-F128	4300035	GEAR	RT0,RTX12709,14709,RTX13709,16709
S-4710	4300119	OIL SEAL	FS5005,5205,6205,5106,5306,6206,6303 MID RANGE
S-A935	4300121	OIL SEAL	FS5106,4205,5205,5306 MID RANGE
S-14096	4300184	SPACER	RTL011610,12610,13610,14610,15610,16610
S-A806	4300190	GEAR-MAINSHAFT	RT0,RTX14609,16709,RTX14710C,15710C,16710C
S-A807	4300191	GEAR-COUNTERSHAFT - USE 4300191	RTX,RTOX14609,13709,16709,RTX14710C,15710C,16710C
S-A936	4300203	OIL SEAL	FS4205,5205 MID RANGE
S-13428	4300204	OIL SEAL	FS4205,5205,6205A,B,C MID RANGE
S-C650	4300238	GEAR-MAINSHAFT - USE 4305068	RTXB16709,15710B,RTL016713,16718
S-7885	4300240	GEAR-MAINSHAFT - USE 21024	RTX16709,RTL016713,16718,18718
S-A876	4300241	GEAR-COUNTERSHAFT	MULTIPLE APPLICATIONS
S-C018	4300242	GEAR-MAINSHAFT	RTX/B/H/16709,RTL016713
S-F014	4300247	GEAR-COUNTERSHAFT	16709,16710,18718,20918
S-10807	4300296	GEAR-MAIN DRIVE	RTL013707DLL,MLL
S-11156	4300297	GEAR-MAINSHAFT	RT013707DLL,MLL
S-11337	4300312	AUX MAINSHAFT	RTX16709B,RTX,RT14710B,C,RTX15710B,C,16710B,C
S-10484	4300325	GEAR-MAINSHAFT	RTX13609
S-A665	4300382	WASHER-MAINSHAFT	MULTIPLE APPLICATIONS
S-A663	4300383	WASHER-MAINSHAFT	MULTIPLE APPLICATIONS
S-A664	4300384	WASHER-MAINSHAFT	MULTIPLE APPLICATIONS
S-11994	4300401	SHIFT FORK	FS4005,4205 MID RANGE
S-A697	4300654	GEAR-MAINSHAFT	
S-C447	4300798	OIL SEAL	FS5106,5306A,CL455,457,282VHD,285VHD MID RANGE
S-A937	4300810	INSERT VALVE	10 SPEED TRANSMISSIONS / MULTIPLE APPLICATIONS
S-C026	4300828	BEARING	14613,14813,15813
S-A662	4300830	WASHER-MAINSHAFT	MULTIPLE APPLICATIONS
S-E775	4300858	GEAR-MAINSHAFT	RTX15710,16710,RTX,RT14710B,RT15710B,13710B
S-C027	4300902	BEARING	
S-E322	4300904	MAINSHAFT	
S-A698	4300907	SLIDING CLUTCH	

LATEST ADDITIONS TO OUR CATALOG

EXCEPT WHERE SPECIFIED, ALL PARTS SUPPLIED ARE S&S/NEWSTAR. USE OF OTHER MANUFACTURERS' NAMES, PART NUMBERS, OR TRADEMARKS ARE FOR INFORMATIONAL AND IDENTIFICATION PURPOSES ONLY.

REPLACEMENT GEARS AND PARTS

APPLICATION: EATON / FULLER TRANSMISSIONS

MODEL APPLICATION

	610	613	910	915	4005	5106	5205	5306	6106	6205	6306	6610	6613	9509	9513	11608	11609	11613	11707	12509	12510	12513	12515	12609	12713	14608	14609	14610	14613	14615	14618	14710	14713	14715	14718	14918	15618	15710	15715	16618	16713	16718	16918	18718	18918	20918					
S-9688	X	X	X	X								X	X	X	X	X				X	X	X	X				X	X	X	X																					
S-6617	X	X	X	X								X	X	X	X	X	X				X	X	X	X			X	X	X	X																					
S-D969																																																			
S-5753	X	X	X	X								X	X	X	X	X	X				X	X	X	X			X	X	X	X																					
S-9752	X	X	X	X								X	X	X	X	X	X				X	X	X	X			X	X	X	X																					
S-7880					X																																														
S-B020																																																			
S-A932																																																			
S-A933																																																			
S-11426																																																			
S-11850					X																																														
S-A934																																																			
S-12028							X																																												
S-F128																																																			
S-4710																																																			
S-A935																																																			
S-14096																																																			
S-A806																																																			
S-A807																																																			
S-A936																																																			
S-13428																																																			
S-C650																																																			
S-B495																																																			
S-A876																																																			
S-C018																																																			
S-F014																																																			
S-10807																																																			
S-11156																																																			
S-11337																																																			
S-10484																																																			
S-A665																																																			
S-A663																																																			
S-A664																																																			
S-11994																																																			
S-A697																													X	X																					
S-C447																																																			
S-A937																																																			
S-C026																																																			
S-A662																																																			
S-E775																																																			
S-C027																																																			
S-E322																																																			
S-A698																									X																										

LATEST ADDITIONS TO OUR CATALOG

EXCEPT WHERE SPECIFIED, ALL PARTS SUPPLIED ARE S&S/NEWSTAR. USE OF OTHER MANUFACTURERS' NAMES, PART NUMBERS, OR TRADEMARKS ARE FOR INFORMATIONAL AND IDENTIFICATION PURPOSES ONLY.



REPLACEMENT GEARS AND PARTS

APPLICATION: EATON / FULLER TRANSMISSIONS

TRANSMISSION

NEW STAR NUMBER	REPLACEMENT FOR PART NUMBER	DESCRIPTION	MODEL APPLICATIONS (ALSO SEE OUR CHART ON THE FOLLOWING PAGE FOR MORE INFORMATION ON SELECT PRODUCT)
S-E298	4300911	SPACER	
S-E932	4300912	WASHER-AUX MAINSHAFT	
S-F015	4300924	SLIDING CLUTCH	FRO-SUPER 10 TRANSMISSIONS
S-F451	4300940	GEAR-MAINSHAFT	
S-E321	4301075	AUX. MAINSHAFT	
S-11407	4301181	GEAR-COUNTERSHAFT	FS5005A,5205A MID RANGE
S-10039	4301220	GEAR-MAINSHAFT	RTX13710,14710,15710,16710
S-13724	4301222	GEAR-MAINSHAFT	RTX11710,12710,13710,14710,15710,16710,C
S-E903	4301400	AUX REDUCTION GEAR	RTL011610B,12610B,13610B,14610B
S-10145	4301403	INPUT SHAFT	
S-10147	4301408	INPUT SHAFT	
S-11966	4301417	BEARING	FR12210B,13210B,14210B,14210B,FRO11210,12210,13210
S-10442	4301466	SYNCHRO CUP	
S-D747	4301467	SYNCHRONIZER CUP	
S-10455	4301468	MAINSHAFT	
S-10146	4301476	CLUTCH HUB	
S-F027	4301477	GEAR-MAINSHAFT	
S-10257	4301478	GEAR-COUNTERSHAFT	
S-11338	4301484	GEAR-MAINSHAFT	
S-E935	4301485	INPUT SHAFT	
S-D447	4301528	GEAR-MAINSHAFT	FS4205 MID RANGE
S-D413	4301529	GEAR-MAINSHAFT	FS4205A,B,C MID RANGE
S-D412	4301530	GEAR-MAINSHAFT	FS4205A,B,C MID RANGE
S-D415	4301531	GEAR-MAINSHAFT	FS4205A,B,C MID RANGE
S-D784	4301532	MAINSHAFT	FS4205A,B,C MID RANGE
S-E582	4301535	GEAR-COUNTERSHAFT	FS4205 MID RANGE
S-D748	4301565	SYNCHRONIZER CUP	FS4205A,B,C MID RANGE
S-C702	4301566	SLIDING CLUTCH	FS4205A,B,C MID RANGE
S-11851	4301614	INPUT SHAFT	FS4205A MID RANGE
S-E268	4301626	INPUT SHAFT	FS4205B,C MID-RANGE
S-D414	4301684	MAINSHAFT	
S-11991	4301686	GEAR-MAINSHAFT	
S-D416	4301688	GEAR-MAINSHAFT	
S-13799	4301689	GEAR-MAINSHAFT	
S-7881	4301717	GEAR-COUNTERSHAFT	
S-E447	4301760	GEAR-MAINSHAFT	FS6205,6305 MID RANGE
S-E448	4301761	GEAR-MAINSHAFT	FS6205,6305 MID RANGE
S-E449	4301762	GEAR-MAINSHAFT	FS6205,6305 MID RANGE
S-F194	4301764	GEAR-MAINSHAFT	
S-11758	4301795	GEAR-AUX MAINSHAFT	
S-13838	4301825	INPUT SHAFT	
S-C649	4301840	SLIDING CLUTCH - REPLACES 4303386	
S-10036	4301842	WASHER-MAINSHAFT	

LATEST ADDITIONS TO OUR CATALOG

EXCEPT WHERE SPECIFIED, ALL PARTS SUPPLIED ARE S&S/NEWSTAR. USE OF OTHER MANUFACTURERS' NAMES, PART NUMBERS, OR TRADEMARKS ARE FOR INFORMATIONAL AND IDENTIFICATION PURPOSES ONLY.

REPLACEMENT GEARS AND PARTS

APPLICATION: EATON / FULLER TRANSMISSIONS

MODEL APPLICATION

	610	613	910	915	4005	5106	5205	5306	6106	6205	6306	6610	6613	9509	9513	11608	11609	11613	11707	12509	12510	12513	12515	12609	12713	14608	14609	14610	14613	14615	14618	14710	14713	14715	14718	14918	15618	15710	15715	16618	16713	16718	16918	18718	18918	20918				
S-E298																									X								X		X					X	X		X							
S-E932																									X									X		X					X	X		X						
S-F015																																																		
S-F451																																																		
S-E321																																			X						X									
S-11407																																																		
S-10039																																																		
S-13724																																																		
S-E903																																																		
S-10145								X			X																																							
S-10147								X			X																																							
S-11966																																																		
S-10442								X																																										
S-D747								X			X																																							
S-10455								X			X																																							
S-10146								X			X																																							
S-F027								X			X																																							
S-10257								X																																										
S-11338								X			X																																							
S-E935								X			X																																							
S-D447																																																		
S-D413																																																		
S-D412																																																		
S-D415																																																		
S-D784																																																		
S-E582																																																		
S-D748																																																		
S-C702																																																		
S-11851																																																		
S-E268																																																		
S-D414								X																																										
S-11991								X																																										
S-D416								X																																										
S-13799								X																																										
S-7881					X																																													
S-E447																																																		
S-E448																																																		
S-E449																																																		
S-F194								X			X																																							
S-11758																																																		
S-13838								X																																										
S-C649																																																		
S-10036																										X										X		X					X	X		X				

LATEST ADDITIONS TO OUR CATALOG

EXCEPT WHERE SPECIFIED, ALL PARTS SUPPLIED ARE S&S/NEWSTAR. USE OF OTHER MANUFACTURERS' NAMES, PART NUMBERS, OR TRADEMARKS ARE FOR INFORMATIONAL AND IDENTIFICATION PURPOSES ONLY.



REPLACEMENT GEARS AND PARTS

APPLICATION: EATON / FULLER TRANSMISSIONS

TRANSMISSION

NEWSTAR NUMBER	REPLACEMENT FOR PART NUMBER	DESCRIPTION	MODEL APPLICATIONS (ALSO SEE OUR CHART ON THE FOLLOWING PAGE FOR MORE INFORMATION ON SELECT PRODUCT)
S-C028	4301851	BEARING	
S-10036	4301842	WASHER-MAINSHAFT	
S-13750	4301855	BEARING ASSEMBLY	RT7608LL, 8609
S-11849	4301877	INPUT SHAFT	
S-D676	4302041	GEAR-MAINSHAFT	
S-E934	4302047	SPACER	
S-14754	4302059	AUX MAINSHAFT	RT015618,RTL014618,16618,14613,14610,15610
S-C029	4302074	BEARING	RTLO16610B
S-F360	4302088	GEAR-MAINSHAFT	RTX15710B,16710B
S-C701	4302089	OD GEAR-COUNTERSHAFT	RTX15710B,16710B
S-D867	4302090	GEAR-MAINSHAFT	RTX16710C
S-F329	4302092	GEAR, OUTPUT SHAFT	RTX16710B
S-13427	4302170	SHIFT FORK	FRO SERIES
S-16164	4302184	SNAP RING	MULTIPLE HEAVY DUTY APPLICATIONS
S-11637	4302243	WASHER-MAINSHAFT	""FRO"" - SUPER 10 SERIES
S-11696	4302258	WASHER-MAINSHAFT	FRO11210B,12210B,13210B,14210B,15210B,16210B
S-E852	4302265	SLIDING CLUTCH	""FRO"" - SUPER 10 SERIES
S-10293	4302271	GEAR	""FRO"" - SUPER 10 SERIES
S-E853	4302315	INPUT SHAFT	11210,12210,13210,14210,15210,16210,B,C
S-10502	4302318	MAINSHAFT	FR,FRO11210B,12210B,13210B,14210B,15210B
S-11853	4302320	COVER, AUX COUNTERSHAFT	11709,12709,13709,14709,16709,11710B,12710B,14710B
S-C480	4302321	FLANGED LOCK NUT	
S-D785	4302381	OD GEAR-MAINSHAFT	16915
S-E866	4302384	GEAR-MAINSHAFT	RTX,RTXF11708LL-2ND SPEED RTX,RTXF11710C,12710C-3RD
S-D786	4302394	GEAR-MAINSHAFT	
S-11406	4302396	GEAR-MAINSHAFT	RTX16709B,RTXF16710C,RTO,RTOF14719MLL
S-E318	4302398	WASHER	
S-13116	4302411	GEAR-MAINSHAFT	FRO11210C,12210C,13210C,14210C,15210C,16210C
S-15629	4302413	GEAR-REDUCTION	FRO11210B,12210B,13210B,14210B,15210B,16210B
S-11486	4302420	GEAR-COUNTERSHAFT	FR,FRO11210B,210B,FRO14210C,16210B,18210C
S-11487	4302421	GEAR-MAINSHAFT	ALL FRO SERIES EXCEPT FRLO 15410-C/16410-C
S-11490	4302422	GEAR-COUNTERSHAFT	FRO14210C,16210C,18210C
S-11242	4302427	REDUCTION GEAR	FRO14210C,18210C
S-F328	4302435	AUX DRIVE GEAR	FRO15210,16210
S-D913	4302479	PIPE ADAPTER	1/8" X 1/8"
S-11489	4302506	GEAR-MAINSHAFT	FRO14210C,15210C,16210C,17210C,18210C
S-D847	4302662	GEAR-MAIN DRIVE	
S-E776	4302666	GEAR-COUNTERSHAFT	
S-C041	4302676	GASKET SHIFT HOUSING	MULTIPLE APPLICATIONS
S-D677	4302695	GEAR-MAINSHAFT	RTLO16610
S-C030	4302712	BEARING	
S-11967	4303120	GEAR-MAINSHAFT	15210,16210
S-E326	4303121	GEAR-COUNTERSHAFT	15210,16210

LATEST ADDITIONS TO OUR CATALOG

EXCEPT WHERE SPECIFIED, ALL PARTS SUPPLIED ARE S&S/NEWSTAR. USE OF OTHER MANUFACTURERS' NAMES, PART NUMBERS, OR TRADEMARKS ARE FOR INFORMATIONAL AND IDENTIFICATION PURPOSES ONLY.

REPLACEMENT GEARS AND PARTS

APPLICATION: EATON / FULLER TRANSMISSIONS

TRANSMISSION

NEW STAR NUMBER	REPLACEMENT FOR PART NUMBER	DESCRIPTION	MODEL APPLICATIONS (ALSO SEE OUR CHART ON THE FOLLOWING PAGE FOR MORE INFORMATION ON SELECT PRODUCT)
S-E867	4303184	GEAR-OVERDRIVE	FR013210C,14210C,15210C,16210C
S-13985	4303185	THRUST WASHER	
S-11442	4303230	GEAR-MAINSHAFT	
S-10038	4303231	GEAR-MAINSHAFT	
S-D403	4303232	GEAR-MAINSHAFT	
S-D417	4303233	GEAR-MAINSHAFT	
S-11992	4303360	GEAR-AUX DRIVE	FR,FR011210C,12210C,13210C,14210C
S-C649	4303386	SLIDING CLUTCH - USE 4301840	
S-F025	4303403	MAINSHAFT	
S-11968	4303406	GEAR-MAINSHAFT	
S-10173	4303409	GEAR-MAINSHAFT	
S-F445	4303412	GEAR-MAINSHAFT	LATE 13 SPEEDS
S-D891	4303420	GEAR-MAINSHAFT	
S-E267	4303422	SPLITTER GEAR	
S-A726	4303431	GASKET W/SILICONE BEADING	MULTIPLE APPLICATIONS
S-F556	4303477	GEAR-MAINSHAFT	
S-F034	4303603	WASHER	
S-D914	4303673	SPACER	
S-C481	4303689	CLUTCH HUB	
S-F485	4303701	GEAR-MAINSHAFT	
S-C384	4303796	GEAR-MAINSHAFT	
S-A938	4303859	COUPLER-MAINSHAFT- NEW STYLE FOR 19131	
S-13614	4303904	GEAR-MAINSHAFT	
S-F017	4303969	GEAR-MAINSHAFT	
S-14755	4304007	GEAR	FRO-FROF11,12,13,14,15,16210B
S-10177	4304013	GEAR-MAINSHAFT	FR015210,16210
S-F420	4304014	SLIDING CLUTCH	FRO/F-15,16210C
S-10456	4304057	GEAR-MAINSHAFT	FS5406A,6406A MID RANGE
S-F226	4304060	GEAR-COUNTERSHAFT	
S-13806	4304073	COUNTERSHAFT	RTL014610,15610,16610,17610
S-C031	4304080	BEARING	13210,14210,15210,16210,17210,18210
S-11825	4304098	GEAR-MAINSHAFT	FS5406A,6406A,FS08406A MID RANGE
S-D411	4304317	SLIDING CLUTCH - REPLACES 22026	
S-10307	4304499	SPACER	
S-E626	4304508	GEAR-COUNTERSHAFT	
S-13609	4304510	GEAR-MAIN DRIVE	
S-13840	4304512	GEAR-COUNTERSHAFT	
S-E724	4304514	GEAR MAINSHAFT	
S-16190	4304541	GEAR-COUNTERSHAFT	FS06406A MID RANGE
S-16163	4304543	GEAR-COUNTERSHAFT	FS06406A, 8406A MID RANGE
S-12029	4304544	GEAR-MAINSHAFT	FS5406A,6406A MID RANGE
S-14088	4304545	MAINSHAFT GEAR	FS5406A,6406A
S-14086	4304549	MAINSHAFT	FS5406A,6406A

LATEST ADDITIONS TO OUR CATALOG

EXCEPT WHERE SPECIFIED, ALL PARTS SUPPLIED ARE S&S/NEWSTAR. USE OF OTHER MANUFACTURERS' NAMES, PART NUMBERS, OR TRADEMARKS ARE FOR INFORMATIONAL AND IDENTIFICATION PURPOSES ONLY.

REPLACEMENT GEARS AND PARTS

APPLICATION: EATON / FULLER TRANSMISSIONS

TRANSMISSION

NEW STAR NUMBER	REPLACEMENT FOR PART NUMBER	DESCRIPTION	MODEL APPLICATIONS (ALSO SEE OUR CHART ON THE FOLLOWING PAGE FOR MORE INFORMATION ON SELECT PRODUCT)
S-C032	4304598	BEARING	
S-A826	4304602	BREATHER	11109,11707,709,12609,610,709,710,713,14109,15813
S-A659	4304614	KEY-MAINSHAFT 3-SIDED	MULTIPLE APPLICATIONS
S-A660	4304615	KEY-MAINSHAFT 3-SIDED	MULTIPLE APPLICATIONS
S-16286	4304618	GEAR-MAINSHAFT	RT015210C, 16210C
S-E851	4304633	INPUT SHAFT - USE S-2822	RT015210C,16210C
S-14756	4304639	MAIN DRIVE GEAR	FRO-FROF11,12,13,14,15,16210B
S-11241	4304642	MAIN DRIVE GEAR	FR018210C
S-F446	4304765	GEAR-COUNTERSHAFT - 18 SPEEDS	
S-E330	4304815	GASKET - REPLACES 20822	
S-C650	4305068	GEAR-MAINSHAFT - REPLACES 4300238	
S-7883	4305069	GEAR-COUNTERSHAFT	
S-F078	4305070	GEAR-MAINSHAFT	
S-A807	4305071	GEAR-COUNTERSHAFT	13609,14609,16709,14710,15710,16710
S-13196	4305230	BELL HOUSING COVER	MULTIPLE APPLICATIONS
S-C701	4305661	GEAR-COUNTERSHAFT	RTX15710B, 16710B
S-6602	4306076	COUNTERSHAFT	
S-C033	5556503	BEARING	
S-16152	5557003	BEARING CONE	MID RANGE FS6205, 6305, 5306, 6306
S-10233	5566507	BEARING - FOR 10,11,13 AND 15 SPEEDS	
S-F452	5566508	BEARING - FOR 13,15 AND 18 SPEEDS	
S-F531	5566510	BEARING	
S-9614	T145A	BEARING & SEAL KIT	
S-9601	T149	BEARING & SEAL KIT	
S-9613	T149AUX	BEARING & SEAL KIT	
S-9600	T203	BEARING & SEAL KIT	11608,609,613,615
S-9602	T205	BEARING & SEAL KIT	
S-9598	T206	BEARING & SEAL KIT	
S-9608	T207	BEARING & SEAL KIT	
S-9615	T211	BEARING & SEAL KIT	12609,610
S-9596	T1000	BEARING & SEAL KIT	906,909,910,913,915,955,958,9508,9509,9513
S-E593	T7032	BEARING & SEAL KIT	

LATEST ADDITIONS TO OUR CATALOG

EXCEPT WHERE SPECIFIED, ALL PARTS SUPPLIED ARE S&S/NEWSTAR. USE OF OTHER MANUFACTURERS' NAMES, PART NUMBERS, OR TRADEMARKS ARE FOR INFORMATIONAL AND IDENTIFICATION PURPOSES ONLY.

AFTERMARKET GYLON® SYNCHRONIZER KITS

APPLICATION: EATON / FULLER TRANSMISSIONS

TRANSMISSION

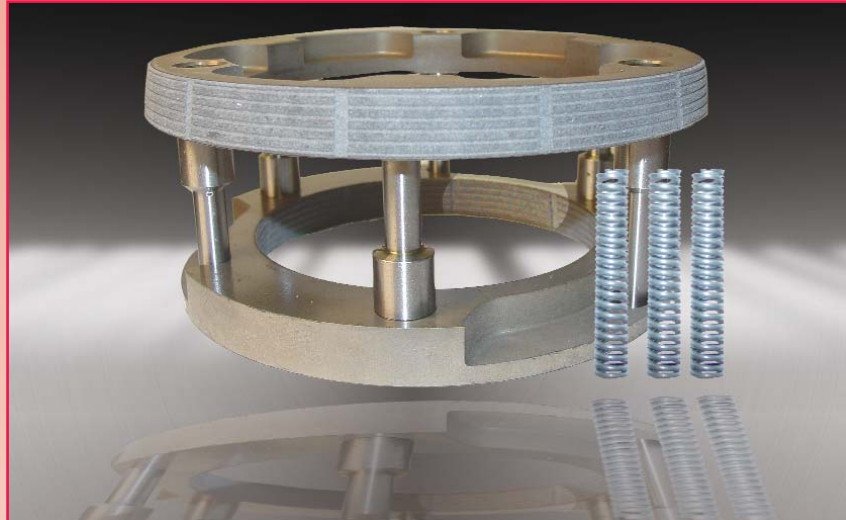

- **INCREASED SYNCHRONIZER LIFE** - PATENTED **GYLON®** FRICTION MATERIAL WITHSTANDS TORSIONAL DRIVELINE VIBRATION AND REDUCES SYNCHRONIZER FAILURES
- **REDUCED MAINTENANCE** - IN COMBINATION WITH REGULARLY SCHEDULED PREVENTIVE MAINTENANCE, FLEET OWNERS WILL EXPERIENCE LOWER TRANSMISSION MAINTENANCE COSTS WHEN USING **NEW★STAR** SYNCHRONIZER KITS
PARTS COMPONENT GROUP
- **ENHANCED CONTAMINATION RESISTANCE** - AS TRANSMISSIONS OPERATE, FOREIGN PARTICLES BECOME IMBEDDED IN THE SYNCHRONIZER FRICTION MATERIAL. THIS CAN CAUSE FAILURES IN OEM SYNCHRONIZERS. PATENTED **GYLON®** FRICTION MATERIAL IS BASED ON **DUPONT TEFLON®** TECHNOLOGY AND IS MUCH MORE DURABLE IN THIS OPERATING ENVIRONMENT, MAKING **NEW★STAR** SYNCHRONIZERS IDEAL FOR REBUILTS.
PARTS COMPONENT GROUP
- **MINIMIZED NEED FOR ADDITIONAL REPLACEMENT COMPONENTS** - PERFORMANCE IMPROVEMENT CAN BE ACHIEVED WITHOUT REPLACING THE ENTIRE RANGE CHANGE SYSTEM, AS IS REQUIRED WITH MANY EARLY OEM ASSEMBLIES.

MADE IN USA

NEW★STAR NUMBER	REPLACEMENT FOR PART NUMBER	SUPERCEDES	DESCRIPTION
S-6523	K-3491	K-2445	SYNCHRONIZER KIT
S-6524	K-3492	K-2446	SYNCHRONIZER KIT



REPLACEMENT RANGE VALVES

APPLICATION: EATON / FULLER TRANSMISSIONS



NEW STAR
NUMBER

S-C462
REPLACEMENT
FOR PART NUMBER:
A-6909



NEW STAR
NUMBER

S-E467
REPLACEMENT
FOR PART NUMBER:
A-6910



NEW STAR
NUMBER

S-C461
REPLACEMENT
FOR PART NUMBER:
A-6913



NEW STAR
NUMBER

S-C460
REPLACEMENT
FOR PART NUMBER:
A-6915



NEW STAR
NUMBER

S-E648
REPLACEMENT
FOR PART NUMBER:
A-6918



NEW STAR
NUMBER

S-E649
R.H. DRIVE
REPLACEMENT
FOR PART NUMBER:
A-7313



NEW STAR
NUMBER

S-E650
R.H. DRIVE
REPLACEMENT FOR
PART NUMBER:
A-7315



NEW STAR
NUMBER

S-E651
R.H. DRIVE
REPLACEMENT FOR
PART NUMBER:
A-7318

REPLACEMENT AIR VALVES

APPLICATION: EATON / FULLER TRANSMISSIONS

TRANSMISSION



AIR VALVE CONVERSION KIT

NEW STAR
NUMBER

REPLACEMENT FOR
PART NUMBER

S-E336

K-3121

CONSISTS OF:

NEW STAR
NUMBER

REPLACEMENT FOR
PART NUMBER

DESCRIPTION

S-D697 4300110
S-D913 4302479
S-D912 84006
S-D969 85003
S-E688 X8C411

SQUARE VALVE
PIPE ADAPTER
BRASS FITTING
ELBOW
BOLT

TRANSMISSION SELECTOR VALVES



NEW STAR
NUMBER

S-8011

REPLACEMENT
FOR PART NUMBER:
A-4487



NEW STAR
NUMBER

S-8800

REPLACEMENT
FOR PART NUMBER:
A-4490



NEW STAR
NUMBER

S-5494

REPLACEMENT
FOR PART NUMBER:
A-4491

AIR CONTROL RANGE VALVE ASSEMBLY



NEW STAR
NUMBER

S-3103

REPLACEMENT
FOR PART NUMBER:
A-3546

SLAVE VALVE ASSEMBLY



NEW STAR
NUMBER

S-8830

REPLACEMENT
FOR PART NUMBER:
A-5000

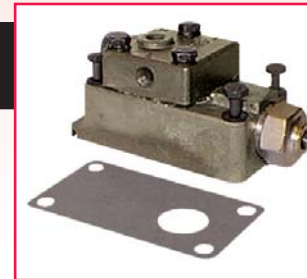

NEW STAR
NUMBER

S-8336

REPLACEMENT
FOR PART NUMBER:
K-2424

REPLACEMENT AIR VALVES

APPLICATION: EATON / FULLER TRANSMISSIONS

FILTER REGULATOR KIT



NEW STAR
NUMBER

S-A210
REPLACEMENT
FOR PART NUMBER:
K-2170

FILTER REGULATOR ASSEMBLY



NEW STAR
NUMBER

S-9146
REPLACEMENT
FOR PART NUMBER:
A-4740

AIR CONTROL SLAVE VALVE

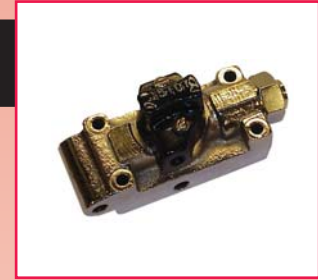

NEW STAR
NUMBER

S-3291
REPLACEMENT
FOR PART NUMBER:
A-4688

TRANSMISSION SPLITTER VALVE



NEW STAR
NUMBER

S-3774
REPLACEMENT
FOR PART NUMBER:
19974

TRANSMISSION DEEP REDUCTION VALVE



NEW STAR
NUMBER

S-8904
REPLACEMENT
FOR PART NUMBER:
14651

TRANSMISSION AIR REGULATOR



NEW STAR
NUMBER

S-2022
REPLACEMENT
FOR PART NUMBER:
16743

TRANSMISSION COUNTERSHAFT
BRAKE ACTUATOR



NEW STAR
NUMBER

S-4397
REPLACEMENT
FOR PART NUMBER:
16859

AIR FILTER ASSEMBLY



NEW STAR
NUMBER

S-6529
REPLACEMENT
FOR PART NUMBER:
A-4041

TRANSMISSION SPLITTER VALVE



NEW STAR
NUMBER

S-A937
REPLACEMENT
FOR PART NUMBER:
4300810

REPLACEMENT MID-RANGE MEDIUM DUTY PARTS

APPLICATION: CLARK / FULLER TRANSMISSIONS



TRANSMISSION

NEW STAR NUMBER	REPLACEMENT FOR PART NUMBER	DESCRIPTION	APPLICATION - MODEL
S-9604	K-2120	BEARING & SEAL KIT	CL450,FS-4005A,B
S-7204	K-2124	GASKET BRG.& SEAL KIT	390V-FORD
S-7213	K-2128	BEARING & SEAL KIT	CL280,282,285 VHD
S-9834	K-2129	BEARING & SEAL KIT	CL450 -LATE STYLE
S-7816	K-2143	GASKET SET	CL450-FORD,GMC,IHC
S-9860	K-2144	SMALL PARTS KIT	CL450
S-6233	216746	M.S. 1ST GEAR	305V,307V-GMC
S-2103	218539	MAINSHAFT	380V-GMC
S-2117	218545	COUNTERSHAFT	320V,380V-FORD,GMC
S-2111	218546	REV. IDLER GEAR	320V,380V-FORD,GMC
S-2113	218879	M.S. 4TH GEAR	300V,307V,327V,387V-FORD,GMC
S-2112	218880	M.S. 4TH GEAR	305V-FORD,GMC
S-10225	219409	GEAR-MAINSHAFT	265-FORD, GMC
S-6236	220255	SYNCHRONIZER	260V-FORD,GMC
S-6239	220273	C.S. 3RD GEAR	260V-FORD
S-6240	220278	M.S. 4TH GEAR	260V-FORD
S-7371	220279	M.S. 3RD GEAR	260V-FORD,GMC
S-6241	220280	GEAR-MAINSHAFT	265-FORD, GMC
S-6242	220522	M.S. 4TH GEAR	260V-FORD,GMC
S-6243	221143	M.S. BUSHING	305V,307V-GMC
S-6244	221480	SYNCHRONIZER	265V,267V,VO,269V-GMC,FORD
S-6246	222960	MAINSHAFT NUT	ALL-FORD,GMC,IHC
S-2707	226701	M.S. BUSHING	300V,310V,320V,380V-FORD,GMC
S-D653	227075	MAINSHAFT	260V FORD
S-A918	227675	INSERT, FORK	280/390/450/550,FS4005
S-2108	227721	GEAR-MAINSHAFT	380,385-FORD
S-2107	227722	M.S. 3RD GEAR	380,385-FORD,GMC
S-2109	227750	SYNCHRONIZER	2ND-3RD
S-6244	228121	SYNCHRONIZER	265V,267V,VO,269V-GMC,FORD
S-8214	228289	MAINSHAFT	280V-FORD,GMC,IHC
S-2709	228296	SYNCHRONIZER CUP	280,290,450,550-FORD,GMC,IHC
S-6298	228299	SEE 238201	282-FORD,GMC,IHC
S-6299	228300	SEE 238202	282-FORD,GMC,IHC
S-4840	228306	SYNCHRONIZER CUP	280,290,450,550-FORD,GMC,IHC
S-6250	228307	SLEEVE, 2ND & 3RD	280V-FORD,GMC,IHC
S-6252	228314	GEAR-COUNTERSHAFT	280-FORD,GMC,IHC
S-6011	228340	INPUT SHAFT	282V,285V-GMC
S-6257	228348	C.S. 4TH GEAR	280V
S-6295	228349	SEE 238198	285-FORD,GMC,IHC
S-6297	228379	SEE 238200	285-FORD,GMC,IHC
S-5740	228578	M.S. 1ST GEAR	280V-FORD,GMC,IHC
S-5741	228580	COUNTERSHAFT	280V-FORD,GMC,IHC
S-4843	228581	REV. IDLER GEAR	280V-FORD,GMC,IHC
S-2105	228603	INPUT SHAFT	385,387-GMC
S-7372	228726	M.S. 2ND GEAR	280V-FORD,IHC
S-2099	228808	MAINSHAFT	327V-GMC
S-2101	228814	GEAR-MAINSHAFT	280, 285 MID RANGE

LATEST ADDITIONS TO OUR CATALOG

EXCEPT WHERE SPECIFIED, ALL PARTS SUPPLIED ARE S&S/NEWSTAR. USE OF OTHER MANUFACTURERS' NAMES, PART NUMBERS, OR TRADEMARKS ARE FOR INFORMATIONAL AND IDENTIFICATION PURPOSES ONLY.

REPLACEMENT MID-RANGE MEDIUM DUTY PARTS

APPLICATION: CLARK / FULLER TRANSMISSIONS

NEW STAR NUMBER	REPLACEMENT FOR PART NUMBER	DESCRIPTION	APPLICATION - MODEL
S-6259	228817	M.S. 1ST & REV GEAR	325V,327V-GMC
S-8438	228955	INPUT SHAFT	282/285
S-6260	229076	SYNCHRONIZER	380,385 FORD
S-5379	229229	SEE 237054	280,450,390,550-FORD,GMC,IHC
S-4841	229230	SEE 237053	280,450,390,550-FORD,GMC,IHC
S-4188	230207	INPUT SHAFT	282V,285V-FORD,GMC
S-9507	233797	FORK & RAIL ASSY.	280,390,550
S-5378	233798	FORK PAD	280,390,550
S-9508	233799	FORK & RAIL ASSY.	280,390,550
S-6265	235351	INPUT SHAFT	551-GMC
S-6266	235353	INPUT SHAFT	551-FORD,GMC
S-6267	235354	INPUT SHAFT	551-FORD,GMC
S-6269	235359	MAINSHAFT	CL550,390V-FORD,GMC
S-6270	235361	MAINSHAFT	CL550,390V FORD,GMC
S-6271	235363	M.S. 1ST GEAR	390,551,558-FORD,GMC,IHC
S-6272	235364	M.S. 1ST GEAR	397,557-FORD,GMC,IHC
S-6273	235365	M.S. REV GEAR	CL550,390V-FORD,GMC,IHC
S-6274	235366	M.S. 2ND GEAR	CL550,390V-FORD,GMC,IHC
S-6275	235367	M.S. 3RD GEAR	390V-FORD,GMC
S-6276	235368	M.S. 3RD GEAR	397V-FORD,GMC
S-6277	235369	M.S. 4TH GEAR	390V-FORD,GMC
S-6278	235370	M.S. 4TH GEAR	397V-FORD,GMC
S-6279	235371	SLEEVE REVERSE	CL550,390V-FORD,GMC,IHC
S-6280	235373	SLEEVE, 1ST	CL550,390V-FORD,GMC,IHC
S-6281	235381	SLEEVE, 3RD & 4TH	CL550,390V-FORD,GMC,IHC
S-6282	235384	COUNTERSHAFT	390,551,558-FORD,GMC,IHC
S-6284	235388	C.S. DRIVE GEAR	390,551-FORD,GMC,IHC
S-6285	235389	GEAR-COUNTERSHAFT	390, 551-FORD
S-6286	235390	C.S. 4TH GEAR	390,551,558-FORD,GMC,IHC
S-6287	235391	C.S. 4TH GEAR	397,557-FORD,GMC,IHC
S-6288	235392	REV. IDLER GEAR	397,557-GMC,IHC
S-6289	235428	MAINSHAFT	CL550,390V-GMC
S-6290	235432	INPUT SHAFT	557-FORD,GMC
S-6291	235433	INPUT SHAFT	390 MID RANGE
S-4841	237053	SYNCHRONIZER	280,450,390,550-FORD,GMC,IHC
S-5379	237054	SYNCHRONIZER	280,450,390,550-FORD,GMC,IHC
S-6295	238198	C.S. 4TH GEAR	285-FORD,GMC,IHC
S-6296	238199	M.S. 4TH GEAR	285-FORD,GMC,IHC
S-6297	238200	M.S. 3RD GEAR	285-FORD,GMC,IHC
S-6298	238201	M.S. 4TH GEAR	282-FORD,GMC,IHC
S-6299	238202	M.S. 3RD GEAR	282-FORD,GMC,IHC
S-6300	239346	M.S. 3RD GEAR	397,557-GMC,FORD,IHC
S-6301	239347	M.S. 4TH GEAR	397,557-FORD,GMC,IHC
S-6302	239348	MAINSHAFT	CL550,390V-FORD,GMC
S-6303	239350	SLEEVE, 3RD & 4TH	CL550,390V-FORD,GMC,IHC
S-6304	239352	M.S. 3RD GEAR	CL550,390V-FORD,GMC,IHC
S-6305	239353	M.S. 4TH GEAR	390,551,558-FORD,GMC,IHC
S-5816	239785	MAINSHAFT	CL450-FORD,GMC,IHC
S-5817	239787	MAINSHAFT	CL450-FORD,GMC,IHC
S-5818	239789	M.S. REV GEAR	CL450-FORD,GMC,IHC
S-5819	239790	M.S. 2ND GEAR	CL450-FORD,GMC,IHC
S-6306	239791	SLEEVE, REV	CL450-FORD,GMC,IHC
S-5820	239792	M.S. 3RD GEAR	CL450-FORD,GMC,IHC
S-5815	239793	M.S. 4TH GEAR	450,455-FORD,GMC,IHC
S-6307	239808	INPUT SHAFT	455,457-GMC
S-7879	239810	INPUT SHAFT	455,457-GMC

LATEST ADDITIONS TO OUR CATALOG

EXCEPT WHERE SPECIFIED, ALL PARTS SUPPLIED ARE S&S/NEWSTAR. USE OF OTHER MANUFACTURERS' NAMES, PART NUMBERS, OR TRADEMARKS ARE FOR INFORMATIONAL AND IDENTIFICATION PURPOSES ONLY.



REPLACEMENT MID-RANGE MEDIUM DUTY PARTS

APPLICATION: CLARK / FULLER TRANSMISSIONS

TRANSMISSION

NEW STAR NUMBER	REPLACEMENT FOR PART NUMBER	DESCRIPTION	APPLICATION - MODEL
S-7626	239815	M.S. 4TH GEAR	CL450-IH
S-E017	239819	SNAP RING	CL450 FORD, GMC
S-5852	239821	RETAINER	FS4005,CL450-GMC
S-5821	239832	SLEEVE, 1ST & REVERSE	CL450-FORD,GMC,IHC
S-A792	240327	WASHER-MAINSHAFT	CL450 USED W/239785
S-5822	241013	C.S. DRIVE GEAR	455,457-FORD,GMC,IHC
S-5823	241014	C.S. 4TH GEAR	455-FORD,GMC,IHC
S-8755	241016	GEAR-COUNTERSHAFT	455-IHC
S-5827	241018	COUNTERSHAFT	CL450-FORD,GMC,IHC
S-6308	802119 (K-2141)	SYNCHRO ASSY. KIT	280,450,390,550-FORD,GMC,IHC
S-6309	802120 (K-2142)	SYNCHRO ASSY. KIT	280,450,390,550-FORD,GMC,IHC
S-10281	2601278	INPUT SHAFT	250,251-5 SPEED- LENGTH 11 5/8"OAL
S-3885	SP-305-50	SMALL PARTS KIT	282,285
S-6167	SP-326-50 802118 (K-2136)	SMALL PARTS KIT	390
S-9860	SP-450-50 (K-2144)	SMALL PARTS KIT	CL450
S-6178	GS-285 802110	GASKET SET	282,285
S-6168	WT-326-55 802116	GASKET SET	390
S-9842	T23	BEARING & SEAL KIT	CL250,265
S-7197	802111	GASKET BEARING & SEAL KIT	285
S-7213	T190 802114 (K-2128)	GASKET BEARING & SEAL KIT	280VHD
S-7204	802117	GASKET BEARING & SEAL KIT	390V-FORD

REPLACEMENT GEARS AND PARTS

APPLICATION: FORD TRANSMISSIONS

NEW STAR NUMBER	REPLACEMENT FOR PART NUMBER	DESCRIPTION	APPLICATION - MODEL
S-16359	76948-04K	BYPASS VALVE AND SLEEVE	AODE, 4R70W / 4R75W
S-16361	76948-09	PRESSURE VALVE	AODE, 4R70W / 4R75W
S-16362	76989K	VALVE AND SLEEVE	AOD
S-16357	77754-04K	VALVE KIT	4L60E, 4L65E
S-16360	96206-01K	BYPASS VALVE AND SLEEVE	AXODE, AX45

LATEST ADDITIONS TO OUR CATALOG

EXCEPT WHERE SPECIFIED, ALL PARTS SUPPLIED ARE S&S/NEWSTAR. USE OF OTHER MANUFACTURERS' NAMES, PART NUMBERS, OR TRADEMARKS ARE FOR INFORMATIONAL AND IDENTIFICATION PURPOSES ONLY.

REPLACEMENT GEARS AND PARTS

APPLICATION: FORD MAZDA / TOYO KOGYO TRANSMISSIONS

USED IN TOYO KOGYO MODEL TK5

NEW STAR NUMBER	REPLACEMENT FOR PART NUMBER	DESCRIPTION	APPLICATION - MODEL
S-9205	E3TZ-7017-E	INPUT SHAFT	'1984' 6 CYL. AEROSTAR, BRONCO II RANGER GAS 4X2, 4X4
S-9206	E3TZ-7113-F	CLUSTER	'1983-85' AEROSTAR, BRONCO II RANGER GAS
S-8948	D67Z-7107-C	SYNCHRO RING 1ST thru 4TH SPEEDS	'1983-87' AEROSTAR, BRONCO II RANGER GAS ALSO 1984 RANGER DIESEL
S-8947	D67Z-7107-B	SYNCHRO RING 5TH and REV. SPEEDS	'1983-87' AEROSTAR, BRONCO II RANGER GAS ALSO 1984 RANGER DIESEL

USED IN MAZDA MODEL M5R1

NEW STAR NUMBER	REPLACEMENT FOR PART NUMBER	DESCRIPTION	APPLICATION - MODEL
S-8949	F1TZ-7107-E	SYNCHRO RING	'1988-92' 1ST thru 4TH SPEEDS AEROSTAR, BRONCO II, EXPLORER RANGER
S-9450	T1488F	BEARING AND SEAL KIT	
S-9800	F0TZ-7017-A	INPUT SHAFT	4.0 LITER-6 CYL. RANGER, BRONCO II '88-93'
S-9801	F0TZ-7113-A	CLUSTER	'1988-93' 140 LITER ENGINES- 6 CYL. BRONCO II, EXPLORER, RANGER

USED IN MAZDA MODEL M5R2

NEW STAR NUMBER	REPLACEMENT FOR PART NUMBER	DESCRIPTION	APPLICATION - MODEL
S-8950	F1TZ-7107-G	SYNCHRO RING 1ST thru 4TH SPEEDS	'1988-92' BRONCO/E AND F150/350
S-8949	F1TZ-7107-E	SYNCHRO RING 5TH SPEEDS	'1988-92' BRONCO/E AND F150/350
S-9451	T1288F	BEARING AND SEAL KIT	

REPLACEMENT GEARS AND PARTS

APPLICATION: FORD MITSUBUSHI 5 SPEED TRANSMISSIONS



TRANSMISSION

NEW★STAR NUMBER	REPLACEMENT FOR PART NUMBER	DESCRIPTION	APPLICATION - MODEL
S-8767	E5TZ-7113-A	CLUSTER	'85-87' RANGER, BRONCO II,4X4 GAS ALL 2.8,2.9 LITER ENGINES FOR MODEL KM145
S-8737	E8TZ-7017-D	INPUT SHAFT	'88-92' RANGER, BRONCO II,4X4 GAS 2.9 LITER ENGINE FOR MODEL KM146
S-8766	F2TZ-7C391-A	UPDATE KIT	BRONCO II,RANGER 4X4 GAS, 2.8,2.9 LITER ENGINES FOR MODELS KM145/146
S-9134	E5TZ-7107-C	SYNCHRO RING 1ST SPEED	RANGER,BRONCO II, 4X4 GAS, 2.8,2.9 LITER ENGINES '85-92'
S-9133	E5TZ-7107-B	SYNCHRO RING 2ND SPEED	RANGER,BRONCO II, 4X4 GAS, 2.8,2.9 LITER ENGINES '85-92'
S-9135	E8TZ-7107-G	SYNCHRO RING 2ND SPEED	RANGER,BRONCO II, 4X4 GAS, 2.9 LITER ENGINE ONLY '88-92'
S-9136	E8TZ-7107-H	SYNCHRO RING REV SPEED	RANGER,BRONCO II, 4X4 GAS, 2.9 LITER ENGINE ONLY '88-92'

REPLACEMENT GEARS AND PARTS

APPLICATION: FORD ZF S5-42 SERIES TRANSMISSIONS

FOR F150/250/350/450
Superduty, F53/59

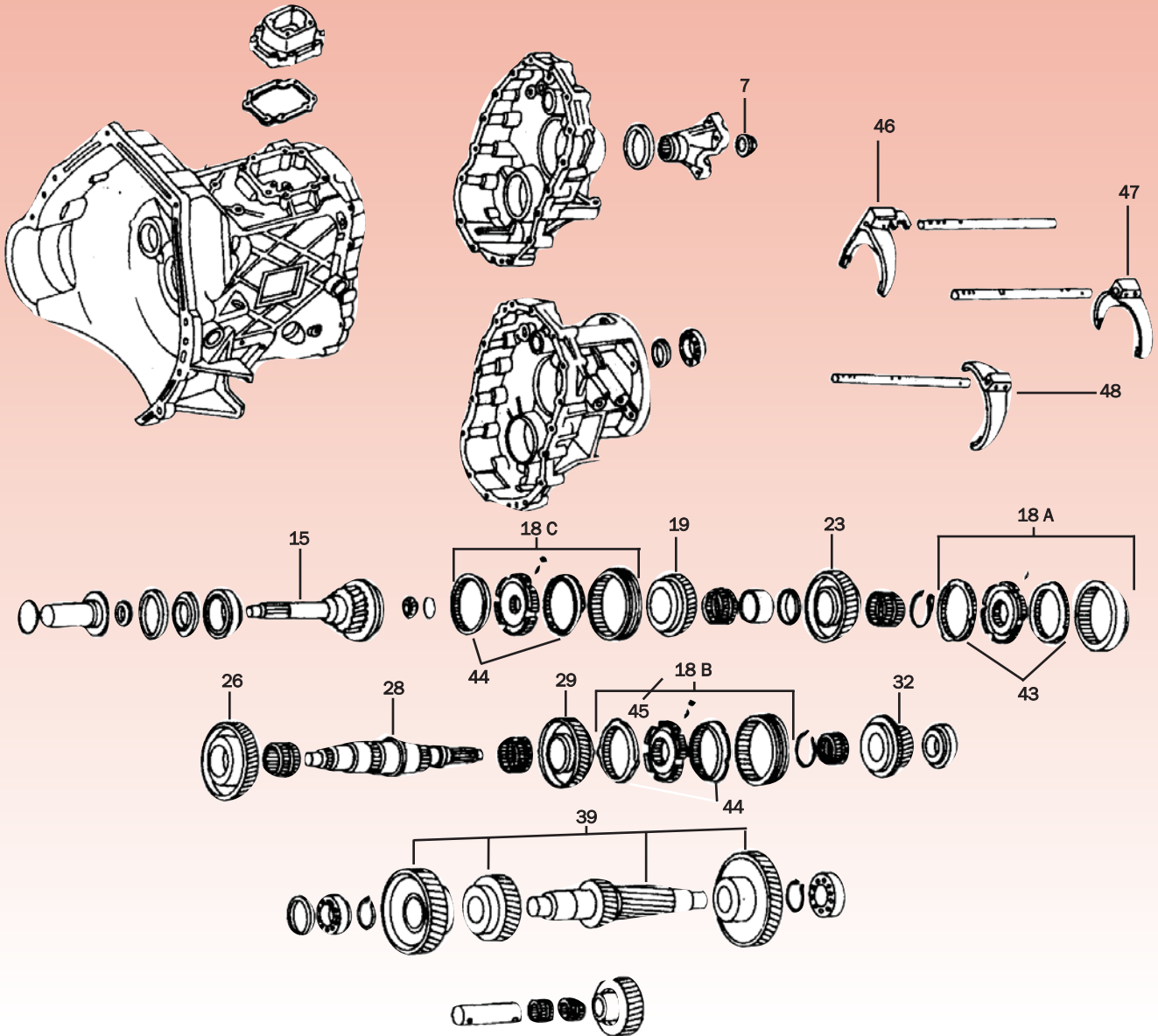

REPLACEMENT GEARS AND PARTS

APPLICATION: FORD ZF S5-42 SERIES TRANSMISSIONS

TRANSMISSION

NEW STAR NUMBER	ILLUSTRATION NUMBER	QTY. REQ'D	REPLACEMENT FOR PART NUMBER	DESCRIPTION
S-8702	15	1	F4TZ-7017-C 1307-202-128	INPUT SHAFT FOR ENGINES: 6.9,7.3 LITER , TRUCK MODELS: F150/250/350/450/53/59-'4X2'/'4X4'
S-8703	15	1	F4TZ-7017-B 1307-202-127	INPUT SHAFT FOR ENGINES: 6.9,7.3,7.5 LITER, TRUCK MODELS: F150/250/350/450/SUPER-'4X2'/'4X4'
S-8704	15	1	F4TZ-7017-A 1307-202-126	INPUT SHAFT FOR ENGINES:4.9,5.8 LITER, TRUCK MODELS: F150/250/350/450/SUPER-'4X2'/'4X4'
S-8482	18A	1	F0TZ-7124-D	SYNCHRONIZER ASSY. 1ST AND 2ND FITS ALL ZF S5-42 TRANSMISSIONS
S-8484	18C	1	F0TZ-7124-E	SYNCHRONIZER ASSY., 3RD AND 4TH FITS ALL ZF S5-42 TRANSMISSIONS
S-8711	19	1	F4TZ-7196-B 1307-204-322	M.S. 3RD GEAR ENGINES: 6.9,7.3 LITER, TRUCK MODELS F150/250/350/450/53/59/SUPER-'4X2'/'4X4'
S-8706	26	1	E9TZ-7100-A 1307-204-298	M.S. 1ST GEAR FITS ALL ZF S5-42 TRANSMISSIONS
S-8709	29	1	F3TZ-7142-A 1307-204-297	M.S. REV GEAR ENGINES: 4.9,5.8,6.9,7.3,7.5 LITER, TRUCK MODELS:F150/250/350/450/53/59-'4X2'/'4X4'
S-8485	43	2	1307-304-181	SYNCHRONIZER RING, 1ST AND 2ND FITS ALL ZF S5-42 TRANSMISSIONS
S-8486	44	3	1307-304-182	SYNCHRONIZER RING, 3RD, 4TH AND 5TH SPEEDS FITS ALL ZF S5-42 TRANSMISSIONS
S-8712	45	1	1307-304-175	SYNCHRONIZER RING, REV. SPEED FITS ALL ZF S5-42 TRANSMISSIONS
S-8618	—	1	F5TZ-7153-A	GASKET KIT - INCLUDES FLANGE NUT FITS ALL ZF S5-42 TRANSMISSIONS
S-9201	—	1	T300ZFX	BEARING AND SEAL INSTALLATION KIT INCLUDES MAINSHAFT BRGS. FITS ALL ZF S5-42 TRANSMISSIONS
S-A294	43,44,45	1	RK1307	SYNCHRONIZER RING KIT FITS ALL ZF S5-42 TRANSMISSIONS
S-A871	—	1	T300ZF-1	BEARING AND SEAL KIT INSTALLATION KIT WITHOUT MAINSHAFT BRGS. FITS ALL ZF S5-42 TRANSMISSIONS



GENUINE GEARS AND PARTS

APPLICATION: ZF TRANSMISSIONS

GENUINE PART NUMBER	DESCRIPTION	GENUINE PART NUMBER	DESCRIPTION
0501-202-797	BREATHER	1307-204-324	5TH GEAR -- M/S
0501-206-040	GEAR SHIFT DETENT	1307-206-003	SHIFT FORK
0501-209-492	SWITCH	1307-218-006	LEVER-GEAR SHIFT
0501-209-815	STOP SCREW ZF/S6-650	1307-298-933	SHIFT FORK
0501-209-879	SCREW DRAIN PLUG	1307-301-011	PIN
0501-210-762	STOP SCREW ZF/S6-650	1307-301-015	REAR HOUSING
0501-211-188	PUMP SHAFT ZF/S6-650	1307-301-041	REAR HOUSING
0501-212-997	CHECK VALVE	1307-301-093	REAR HOUSING
0501-309-612	NILOS RING S5-42/S5 -47/S5-47	1307-301-148	FIXING PLATE
0501-317-729	SNAP RING ZF/S6-650	1307-302-060	QUILL TUBE
0630-302-090	SPRING WASHER	1307-303-014	4TH GEAR-C/S
0630-532-128	SNAP RING ZF/S6-650	1307-303-015	4TH GEAR-C/S -- 41T
0630-532-207	INDENTED RING-CHK VALVE ZJ15F	1307-303-060	4TH GEAR-C/S
0631-306-154	DOWEL PIN	1307-303-109	3RD GEAR-C/S 34 TEETH
0631-306-719	CYLINDRICAL CASE ZF/S6-650	1307-303-110	HELICAL GEAR
0631-329-017	ZF/S6-650..ROLL PIN/ 3X24	1307-303-112	HELICAL GEAR
0631-329-028	ZF/S6-650..SLOT PIN/ 3.5X30	1307-303-113	5TH GEAR-C/S
0631-329-050	ZF/S6-650..SLOT PIN/ 5X24	1307-303-115	1ST/2ND/3RD GEAR-C/S
0631-329-069	ZF/S6-650..SLOT PIN/ 6X30	1307-304-073	YOKE GAS ENGINES ZF/S5-42
0634-801-027	SEAL RING	1307-304-079	YOKE
0636-010-374	CASE SCREWS	1307-304-166	1ST/2ND SYNC BODY
0636-015-299	QUILL BOLTS	1307-304-167	5TH/REV. SYNCRO BODY
0636-015-545	ZF/S6-650...HEX SCREW	1307-304-168	3RD/4TH SYNCRO BODY
0636-101-356	ZF/S6-650...CAP SCREW 8X.35	1307-304-175	SYNCHRO RING, 5TH & REV
0636-101-663	ZF/S6-650 CAP SCREW 8X.50/REQ.	1307-304-181	SYNCHRO RING, 1ST & 2ND
0636-304-047R	PLUG-M12X1.5	1307-304-182	SYNCHRO RING 3RD & 4TH
0730-162-813	THRUST WASHER FOR S6-650	1307-304-352	MAINSHAFT
0730-505-093	ZF/S6-650..SNAP RING	1307-304-353	MAINSHAFT
0732-041-946	ZF/S6-650..DETENT SPRING	1307-304-370	ZF/S5-42..1ST/2ND SLIDING SLEEVE
0732-041-947	COMPRESSION SPRING	1307-304-371	ZF/S5-42..3RD/4TH SLIDING SLEEVE
0734-310-377	OUTPUT SEAL (4X4)	1307-304-372	SLIDING SLEEVE-5/REV
0734-310-378	INPUT SEAL	1307-305-003	PIN-IDLER SHAFT
0736-010-258	ZF/S6-650...SCREW	1307-306-019	SHIFT FORK
0736-304-150	SCREW PLUG	1307-306-035	SHIFT FORK-5TH
0736-617-043	ZF/S6-650..HEX SCREW	1307-306-046	HOUSING-GEAR SHIFT
0750-101-028	ZF/S6-650..CYLINDRICAL REAR C	1307-306-062	GEAR SHIFT FINGER
1048-301-010	ZF/S6-650..MAGNET	1307-306-063	GEAR SHIFT FINGER
1304-301-035	PTO PLATES/COVER	1307-306-146	GEAR SHIFT FINGER
1307-050-050ZW	S5-42 GAS 4X2 5SPD 4.9/5.8L	1307-306-148	GEAR SHIFT FINGER
1307-050-053ZW	S5-42 GAS 4X2 5SPD 7.5L	1307-306-154	GUIDE PIECE
1307-050-056ZW	S5-42 DIESEL 4X2 5SPD 6.9/7.3L	1307-306-169	SHIFT RAIL-3RD/4TH
1307-050-108ZW	S5-42 DIT-DIESEL 4X2 5SPD 7.3L	1307-306-170	DETENT PIN
1307-050-109ZW	S5-42 DIT-DIESEL 4X4SD 5SP 7.3	1307-306-219	SHIFT RAIL-5TH/REV.
1307-050-120ZW	S5-42 GAS 4X4 5SPD 7.5L	1307-306-229	STOP PLATE
1307-201-076	FRONT MAIN HOUSING	1307-306-230	SHIFTER INTERLOCK
1307-202-126	INPUT SHAFT	1307-306-236	BOOT-INNER TRANSM.
1307-202-127	INPUT SHAFT	1307-MAJOR	BEARING KIT INCL NEEDLE BEARING
1307-202-128	INPUT SHAFT	1307-MINOR	BEARING KIT W/O NEEDLE BEARING
1307-203-036	COUNTERSHAFT	1307PPK	POPPET KIT / PRESSURE PIECE KIT
1307-203-037	COUNTERSHAFT	1307RBK	REBUILD KIT / SMALL PARTS KIT
1307-204-239	5TH/REV SYNCHRO ASSY.	1307SK	SYNCHRO RING KIT
1307-204-243	1ST/2ND SYNCRO ASSY.	1307SMK	SHIM KIT
1307-204-244	3RD/4TH SYNCHRO ASSY.	1307SRK	SNAP RING KIT
1307-204-297	MS REV. GEAR	1308-302-029	NILOS RING
1307-204-298	1ST GEAR - M/S	1317-050-003ZW	S5-47 DIESEL 4X2 5SPD 7.3L
1307-204-319	2ND GEAR	1317-050-012ZW	S5-47 DIESEL 4X4 5SPD 7.3L
1307-204-320	2ND GEAR - M/S	1317-050-016ZW	TRANSMISSION S547M 5.4L/6.8L
1307-204-321	3RD GEAR	1317-201-015	MAIN HOUSING
1307-204-322	3RD GEAR - M/S	1317-202-015	INPUT SHAFT
1307-204-323	5TH GEAR	1317-202-016	INPUT SHAFT --10S-29-48T

GENUINE GEARS AND PARTS

APPLICATION: ZF TRANSMISSIONS

TRANSMISSION

GENUINE PART NUMBER	DESCRIPTION	GENUINE PART NUMBER	DESCRIPTION
1317-202-017	INPUT SHAFT	1319-204-025	3RD/4TH SYNCHRO ASSY
1317-202-033	INPUT SHAFT	1319-204-026	REV. GEAR-M/S
1317-203-010	COUNTERSHAFT ASSY.	1319-204-027	1ST GEAR-M/S
1317-203-012	COUNTERSHAFT ASSY.	1319-204-030	CIRCULAR FLANGE
1317-204-006	3RD GEAR-M/S	1319-204-038	1ST/2ND SYNCHRO ASSY -W/TORQUE
1317-204-007	3RD GEAR-M/S	1319-218-004	GEAR SHIFT LEVER
1317-204-015	REV. GEAR-M/S	1319-220-008	PUMP HOUSING
1317-204-018	5TH GEAR-M/S -26-48T	1319-301-012	OIL FEEDER
1317-204-019	5TH GEAR-M/S -25-48T	1319-301-047	INTERMEDIATE HOUSING
1317-204-024	2ND GEAR-M/S	1319-301-072	REAR HOUSING
1317-204-029	SYNCHRO ASSY-1ST/2ND	1319-301-073	REAR HOUSING
1317-204-032	1ST GEAR-M/S	1319-302-009	QUILL TUBE
1317-204-038	SYNCHRO ASSY-5TH/REV	1319-303-046	SPACER
1317-204-056	SYNCHRO ASSY-3RD/4TH	1319-303-047	SYNCHRO BODY-5TH
1317-206-004	SHIFT ISOLATOR	1319-303-048	C/S ASSY-1ST/2ND/REV
1317-298-001	1ST/2ND FORK ASSY.	1319-303-049	4TH GEAR-C/S
1317-301-034	REAR HOUSING	1319-303-050	3RD GEAR-C/S
1317-302-010	QUILL TUBE-INPUT	1319-303-052	5TH GEAR-C/S
1317-302-041	QUILL TUBE-INPUT	1319-304-018	SYNCHRO BODY-3RD/4TH
1317-303-013	3RD GEAR-C/S	1319-304-019	SYNCHRO BODY-1ST/REV
1317-303-016	5TH GEAR-C/S	1319-304-032	INNER SYNC RING-1/2
1317-304-026	SYNCHRO BODY-3RD/4TH	1319-304-053	OUTER SYNC RING-1/2
1317-304-031	SYNCHRO BODY-1ST/2ND	1319-304-068	SYNC BODY-1/2ND LOW TORQUE CAN
1317-304-035	SYNCHRO BODY-5TH/REV	1319-304-069	MAINSHAFT 4X2
1317-304-038	SYNCHRO RING-REV.	1319-304-070	MAINSHAFT 4X4
1317-304-066	MAINSHAFT	1319-304-075	INTERMEDIATE SYNCRO RING-1ST/2
1317-304-149	SYNCHRO RING	1319-304-077	1ST GEAR-M/S
1317-304-150	SYNCHRO RING	1319-304-087	MAINSHAFT GM S-650
1317-304-157	SLIDING SLEEVE-1/2ND	1319-304-088	SYNC BODY-1/2ND HIGH TORQUE-HA
1317-304-158	SLIDING SLEEVE-3RD/4TH/5TH/REV	1319-304-089	MAINSHAFT GM S-650
1317-305-004	IDLER GEAR	1319-304-092	SLIDING SLEEVE-1/2ND
1317-306-001	GR.SHIFT LEVER	1319-304-094	MAINSHAFT-4X4
1317-306-002	GEAR SHIFT FINGER	1319-304-095	MAINSHAFT-4X2
1317-306-003	GR.SHIFT SHAFT	1319-305-006	REV IDLER SUPPORT
1317-306-004	GR.SHIFT SHAFT	1319-305-007	REV IDLER SHAFT
1317-306-005	5TH/REV.GR.SHIFT RAIL	1319-305-010	IDLER GEAR
1317-306-006	3TH/4TH GR.SHIFT RAIL	1319-306-022	SHIFT FINGER-FRONT
1317-306-014	BELLOWS	1319-306-034	SHIFT FINGER-REAR
1317PPK	SYN>POPPET & SPRING KIT	1319-306-043	GEAR SHIFT HOUSING
1317SK	SYNCHRO RING KIT 6 RINGS Z-F S	1319-306-044	SHIFT RAIL-1ST/REV.
1319-050-005ZW	S6-650 DIESEL 4X2 6SPD 7.3L	1319-306-045	SHIFT FORK-1ST/REV.
1319-050-006ZW	TRANSMISSION-S6-650SD 7.3L 4X4	1319-306-046	SHIFT RAIL-5TH
1319-050-045ZW	S6-650 HT-DIESEL 4X2 7.3L	1319-306-047	SHIFT FORK-5TH
1319-050-046ZW	S6-650 HT-DIESEL 4X4 7.3L	1319-306-048	INTERLOCKING PLATE
1319-051-001ZW	S6-750 4X2 6.0L	1319-306-050	SHIFT RAIL-1/2
1319-051-003ZW	S6-750 4X4 6L	1319-306-051	SHIFT RAIL-3/4
1319-051-004ZW	S6-750 4X2 6.0L	1319-306-057	ZF/S6-650...MAIN SHIFT RAIL
1319-051-005ZW	S6-750 4X4 6.0L	1319-306-058	SHIFT DRIVER
1319-051-006ZW	S6-750	1319-306-060	COLLAR SCREEN
1319-201-001	MAIN HOUSING	1319-306-061	ZF/S6-650...INNER TRANS BOOT
1319-202-017	INPUT SHAFT GM S-650	1319-306-080	GUIDE BUSHING- MAIN DETENT
1319-202-018	INPUT SHAFT GM S-650	1319-MAJOR	BEARING KIT W/NEEDLE BEARINGS
1319-202-024	INPUT SHAFT (6S-750)	1319-MINOR	BEARING KIT W/O NEEDLE BEARING
1319-202-026	INPUT SHAFT	1319PPK	KIT-SYNCHRO POPPET & SPRINGS
1319-203-024	COUNTERSHAFT ASSY.	1319RBK	REBUILD KIT / SMALL PARTS KIT
1319-203-029	5TH SYNCHRO ASSY.	1319SK	KIT-SYNCHRO RINGS
1319-204-008	ZF/S6-650...1ST/2ND SYN.ASSY.	1319SMK	SHIM KIT (S6-650)
1319-204-011	3RD GEAR-M/S	1319SRK	KIT-SNAP RINGS
1319-204-013	2ND GEAR-M/S	6S750-MAJOR	MAJOR BEARING KIT (6S750)
1319-204-024	SYNCHRO ASSY-1ST/2ND	6S750-MINOR	BEARING KIT

REPLACEMENT GEARS AND PARTS

APPLICATION: GM / MUNCIE SM465 TRANSMISSIONS

NEW STAR NUMBER	REPLACEMENT FOR PART NUMBER	DESCRIPTION	APPLICATION - MODEL
S-6644	465449	SEE 14053671	COUNTERSHAFT
S-8199	465455	WT304-19B	BUSHING
S-4016	476766	WT304-12	M.S. 1ST GEAR
S-8208	794381	WT304-28	SHIFT LEVER
S-8380	3830575	WT304-90	MAINSHAFT NUT
S-9003	3866359	PART OF AWT304-80 SM465	SPRING
S-3440	3901137	WT304-22	FORK, 1ST & 2ND
S-3441	3901138	WT304-22A	FORK, 3RD & 4TH
S-6013	3901141	WT304-10	REV. IDLER GEAR
S-7236	3901158	WT304-21	M.S. 2ND GEAR
S-4014	3901161	WT304-11	M.S. 3RD GEAR
S-6631	3901164	WT304-2.5	M.S. 3RD & 4TH HUB
S-4522	3901165	WT304-15	M.S. SLEEVE 3RD & 4TH
S-6014	3901170	WT304-36	M.S. REV GEAR
S-6632	3901175	WT304-16A	MAIN DRIVE GEAR
S-6633	3901176	WT304-16	MAIN DRIVE GEAR
S-6164	3930800	WT304-55	GASKET SET
S-3438	3932253	WT304-19	BUSHING, 1ST & 2ND
S-4016	3932256	SEE 476766	M.S. 1ST GEAR
S-4015	3932265	WT304-2A	MAINSHAFT
S-C609	3932267	SM465	THRUST WASHER
S-C610	3932268	SM465	THRUST WASHER
S-3439	3932274	WT304-19A	BUSHING, 3RD
S-6636	3946776	WT304-81	M.S. 1ST, 2ND & REV HUB
S-6637	3950367	WT304-83A	RING, 1ST, 2ND & REV
S-6638	3955570	WT304-9A	GEAR-COUNTERSHAFT
S-6639	3968038	WT304-34	C.S. 3RD GEAR
S-6055	3993036	WT304-14A	RING, 3RD & 4TH
S-6641	6259663	AWT304-2C	MAINSHAFT
S-7195	8885008	—	BRG AND SEAL KIT
S-3652	—	AWT304-2.5	SYNCHRONIZER
S-3653	—	AWT304-80	SYNCHRONIZER
S-5951	14020811	WT304-17/ WT304-91	C.S. SLEEVE
S-6644	14053671	WT304-3A	COUNTERSHAFT
S-6632	15588219	SEE 3901175	MAIN DRIVE GEAR
S-4040	SP-304-50	SM465	SMALL PARTS KIT
S-6163	WT-304-11AX	—	GEAR KIT

LATEST ADDITIONS TO OUR CATALOG

EXCEPT WHERE SPECIFIED, ALL PARTS SUPPLIED ARE S&S/NEWSTAR. USE OF OTHER MANUFACTURERS' NAMES, PART NUMBERS, OR TRADEMARKS ARE FOR INFORMATIONAL AND IDENTIFICATION PURPOSES ONLY.



REPLACEMENT GEARS AND PARTS

APPLICATION: INTERNATIONAL TRUCK APPLICATIONS

TRANSMISSION

NEWSTAR NUMBER	REPLACEMENT FOR PART NUMBER	DESCRIPTION	APPLICATION - MODEL
S-5094	18521R1	MAINSHAFT NUT	T-495,496
S-4630	111082R1	PTO GASKET	T-34,35,36,495,496,698,699
S-A094	238582R31	INPUT SHAFT	T-34,36
S-4573	238585R1	C.S. DRIVE GEAR	T-34,35,36,495,496,698,699
S-4592	238589R1	C.S. 3RD GEAR	T-34,35,36,495,496,698,699
S-4390	238598R31	MAINSHAFT	T-34,35,36
S-4580	238599R1	M.S. 1ST GEAR	T-34,35,36
S-6835	238609R94	SYNCHRONIZER	T-34,35,36,495,496,698,699
S-4578	238612R3	M.S. 4TH GEAR	T-34,35,36,495,496,698,699
S-2272	238614R92	SYNCHRONIZER	T-34,35,36,495,496,698,699
S-7214	281817C96 (T156)	BEARING AND SEAL KIT	T-34,35,36,495,496
S-2526	401097C3	FORK 2ND AND 3RD	T-495,496,698,699
S-4271	440276C2	COUNTERSHAFT	T-495,496,698,699
S-4270	440279C1	REV IDLER GEAR	T-495,496
S-7239	440283C2	MAINSHAFT	T-495,496
S-4264	440285C2	MAIN DRIVE GEAR	T-495,496,698,699
S-4267	440286C2	MAIN DRIVE GEAR	T-495,496,698,699
S-4263	440287C1	INPUT SHAFT	T-495,496,698,699
S-4390	453408C91	MAINSHAFT KIT	USE 238598R31
S-4271	469143C91	COUNTERSHAFT KIT	USE 440276C2
S-4266	474077C1	CLUTCH HUB	T-495,496
S-7244	474078C1	M.S. 1ST GEAR	T-495,496
S-4542	487871C1	M.S. REV GEAR	T-698,699
S-4543	487872C1	M.S. 1ST GEAR	T-698,699
S-4544	487873C1	M.S. 2ND GEAR	T-698,699
S-4545	487874C1	CLUTCH HUB	T-698,699
S-4546	487875C1	MAINSHAFT	T-698,699
S-3665	508054C1	FORK 4TH AND 5TH	T-495,496,698,699
S-4574	863822R1	COUNTERSHAFT	T-34,35,36
S-4588	863823R3	M.S. 2ND GEAR	T-34,35,36,495,496
S-6165	876641R93	GASKET SET	T-34,35,36
S-6166	WT-320-50B	SMALL PARTS KIT	T-698,699
S-5505	SP-325-50	SMALL PARTS KIT	T-495,496



LATEST ADDITIONS TO OUR CATALOG

EXCEPT WHERE SPECIFIED, ALL PARTS SUPPLIED ARE S&S/NEWSTAR. USE OF OTHER MANUFACTURERS' NAMES, PART NUMBERS, OR TRADEMARKS ARE FOR INFORMATIONAL AND IDENTIFICATION PURPOSES ONLY.

REPLACEMENT GEARS AND PARTS

APPLICATION: MACK TRANSMISSIONS

NEW STAR NUMBER	REPLACEMENT FOR MACK NUMBER	DESCRIPTION	APPLICATION - MODEL	REPLACEMENT FOR PAI/EXCEL
S-5257	3-AX-1749-X	BOLT	TRQ-7220,TRL-1076,1078	6060
S-5257	3-AX-1803-X	BOLT	TRQ-7220,TRL-1076,1078,T-2090	6060
S-7621	21-AX-360	NUT	T-2090	5977
S-5956	56-AX-432	O-RING	T-2090	2500
S-9704	88-AX-391-P2	OIL SEAL	TRXL,TRDL107,TRTXL-1070	6950
S-8604	88-AX-440-P4	OIL SEAL	TRL-107,1076,1078	7310
S-4366	88-AX-471	OIL SEAL	T-2070, 2090, 2100	6954
S-10137	320-KB-332-F	SLIDING CLUTCH	TRTXL107,1070	2604
S-7635	320-KB-340-A	CLUTCH GR., 2ND & 3RD	TRDL-107,TRXL-107	2601
S-9397	320-KB-450-C	CLUTCH	T-2090	2532
S-10059	320-KB-459-A	SLIDING CLUTCH	T2080,2090,2100	2542
S-6039	320-KB-2119	CLUTCH GR., LO DIRECT	TRXL-107,TRDL/TRDLG,TRTXL-1070	2602
S-6040	320-KB-2126-A	CLUTCH GR., 4TH & 5TH	TRL-1076,1078,TRXL-107	2531
S-6039	320-KB-3119	CLUTCH GR., LO DIRECT	TRXL-107, TRDL,TRDLG,TRTXL-1070	2602
S-9695	320-KB-3136	SLIDING CLUTCH GEAR	T-2050,2060,2070,2090,T-2100,2130,2180	2527
S-9857	320-KB-3137-A	GEAR	T-2090,2100,2130,T2	2534
S-10066	320-KB-3141	CLUTCH	T2130,2180	2634
S-16382	320-KB-3147	SYNCHRONIZER	T-2080,2090,2100,2130,2180	2504
S-13809	320-KB-3150	SYNCHRONIZER		
S-B355	495-KB-361	STEEL PLATE QTY PK OF 8	T-2090,2100,2130,2180	2525
S-B356	495-KB-367	FRICITION DISC QTY PK OF 8	T-2090,2100,2130,2180	2526
S-B090	541-KB-29	BREATHER	TRL-107,1076,1078,REAR CASE	6440
S-9951	575-KB-450	FORK	T2090,2100,2180	0659
S-C394	575-KB-3303-C	FORK, 4TH & 5TH	T-2050,2060,2070,2090,2100	0632
S-7512	736-KB-318-A	REVERSE IDLER GEAR	TRL-1076,1078,TRXL-107	6271
S-6042	751-KB-223-B	REVERSE IDLER GEAR	TRL-1076,1078,TRXL-107	6321
S-F132	751-KB-257-B	REVERSE IDLER GEAR	TRL1076,1078,TRXL107	6322
S-6043	751-KB-3108	M.S. 3RD GEAR	TRL-1076,1078,TRXL-107	6231
S-6044	751-KB-3109-B	M.S. 4TH GEAR	TRL-1076,1078,TRDL-107	1711
S-F405	751-KB-3341-B	GEAR-MAINSHAFT	T2090,2130,2180	6471
S-9398	751-KB-3450-B	M.S. GEAR, O.D. HIGH GR.	T-2090,2100	6252
S-10067	751-KB-3491	DRIVE GEAR	T2130,2180	6464
S-F131	751-KB-4123	AUX GEAR-MAINSHAFT	T2070,2080B,2130,2180	6199
S-F406	757-KB-428	GEAR-COUNTERSHAFT	T2090,2100,2130,2180	6373
S-10501	757-KB-434	GEAR-COUNTERSHAFT	T2090,2130,2180	6374
S-10158	757-KB-444	GEAR-COUNTERSHAFT	T2050,2060,2070	6484
S-6045	764-KB-499-BP1	MAIN DRIVE GEAR	TRXL-107,TRDL,TRDLG-1070	6731
S-6045	764-KB-499-C	MAIN DRIVE GEAR	TRXL-107,TRDL,TRDLG-1070	6731
S-6045	764-KB-1223-AP1	MAIN DRIVE GEAR	TRXL-107,TRDL,TRDLG-1070	6731
S-7636	764-KB-3203	MAIN DRIVE GEAR	TRXL-107	6423
S-7636	764-KB-3203-B	MAIN DRIVE GEAR	TRXL-107	6423
S-E876	764-KB-3264-A	SPUR PINION	T2090,2130,2180	6723
S-6046	764-KB-495-P1	MAIN DRIVE GEAR	TRDL-107,TRL-1076,1078	6732
S-6046	764-KB-4138-AP1	MAIN DRIVE GEAR	TRDL-107,TRL-1076,1078	6732
S-6046	764-KB-4138-B	MAIN DRIVE GEAR	TRDL-107,TRL-1076,1078	6732
S-10222	764-KB-4140-B	INPUT SHAFT	TRTXL107,1070	6734
S-9248	764-KB-4203-E	INPUT SHAFT	T-2090,2130,2180	6735
S-9399	764-KB-4248	MAIN DRIVE GEAR	T-2090,2100	6429
S-F159	764-KB-4270	DRIVE GEAR	T2080C,2090,2100	6202
S-12110	53-KC-486-C	SYNCHRO HOUSING	T2090,2100,2130,2180	2515
S-F130	84-KC-46	HUB-LOW RANGE	T2090,2100,T2080C	6203
S-F473	84-KC-47	HUB-LOW RANGE	T2130,2180,T2080C	6198
S-5962	604-KC-31	CLUTCH SHAFT	TRXL-107,INVOLUTE SPLINE	6125
S-F158	605-KC-3183-A	COUNTERSHAFT	TRDL-107	6052
S-F129	605-KC-3184-A	COUNTERSHAFT	TRTXL-1070	6053
S-5947	611-KC-118	SHAFT	TRL-1076/1078,107	6120

LATEST ADDITIONS TO OUR CATALOG

EXCEPT WHERE SPECIFIED, ALL PARTS SUPPLIED ARE S&S/NEWSTAR. USE OF OTHER MANUFACTURERS' NAMES, PART NUMBERS, OR TRADEMARKS ARE FOR INFORMATIONAL AND IDENTIFICATION PURPOSES ONLY.



REPLACEMENT GEARS AND PARTS

APPLICATION: MACK TRANSMISSIONS

TRANSMISSION

NEWSTAR NUMBER	REPLACEMENT FOR MACK NUMBER	DESCRIPTION	APPLICATION - MODEL	REPLACEMENT FOR PAI/EXCEL
S-B825	615-KC-4203	MAINSHAFT	T-2060	6648
S-7619	789-KC-117	SLEEVE	TRXL-107,TRQ-7220,T-2090	6960
S-10338	223-KD-241	THRUST WASHER	T2090,2100,2130,2180	5999
S-10339	223-KD-249	THRUST WASHER	T2090,2100,2130,2180	5998
S-9968	223-KD-253	WASHER	T2050,2070,2090	5985
S-11852	223-KD-261-A	THRUST WASHER	T2090,2100	5997
S-11997	223-KD-262	THRUST WASHER	T2060,2070,2090,2100,2130,2180	5972
S-11998	223-KD-262-P2	THRUST WASHER	T2060,2070,2090,2100,2130,2180	5973
S-9969	223-KD-316-A	WASHER	T-2050,2070,2090	5983
S-13424	223-KD-317-A	THRUST WASHER	T2090,2100,2130,2180	5984
S-11999	233-KD-39	THRUST WASHER	T2060,2070,2090,2100,2130,2180	5994
S-2938	1-MR-2297	REVERSE SWITCH	TRQ-7220,TRQ-1076,1078,T-2090	4396
S-9603	208-SH-84	BEARING & SEAL KIT	TRXL 107,1071	6561
S-13213	208-SH-101-A	BEARING & SEAL KIT	T2060,2070,2080,2090,2100,2130,2180	6565
S-B905	208-SH-105	BEARING & SEAL KIT	TR107,TRL1076,1078	6563

ASK YOUR SALES REP FOR INFORMATION ON
NEWSTAR REPLACEMENT 22SI ALTERNATORS
AND 42MT STARTERS FOR MEDIUM AND
HEAVY DUTY APPLICATIONS



REPLACEMENT GEARS AND PARTS

APPLICATION: NEW PROCESS TRANSMISSIONS



NEW STAR NUMBER	REPLACEMENT FOR PART NUMBER	DESCRIPTION	APPLICATION - MODEL
S-6672	10332	BEARING & SEAL KIT	4590-IHC
S-6821	11118	COUNTERSHAFT	540,541-GM,IHC,DODGE
S-6673	11188	SLIDING CLUTCH	540 REVERSE BOX
S-7269	11189	MAIN DRIVE GEAR	540 REVERSE BOX
S-6675	11192	OUTPUT GEAR	540 REVERSE BOX
S-6676	11193	CLUTCH GEAR	540 REVERSE BOX
S-7427	11239	MAIN DRIVE GEAR	540 REVERSE BOX
S-6823	11294	CLUTCH HUB	540-GM,IHC,DODGE,FORD,IHC- T34,35,36,495,496,698,699
S-6815	11306	LEVER	435
S-4969	11334	OUTER RING	435,540,7550,7590-FORD,GM,IHC,DODGE
S-2501	11337	SYNCHRONIZER	540 FORD,GM,IHC,DODGE
S-4776	11338	SYNCHRONIZER	435 FORD,GM,IHC,DODGE
S-6683	11367	SYNCHRONIZER	7550,7590-IH
S-6684	11368	SYNCHRONIZER	7550,7590 DODGE
S-4650	11370	OUTER RING	541,542 FORD,GM,IHC,DODGE, T35,36,495,496,698,699-IHC
S-6686	11425	SYNCHRONIZER	435,541,542 GM,IHC,DODGE
S-6690	11562	SYNCHRONIZER	435 FORD,DODGE
S-6691	11563	SYNCHRONIZER	7550,7590,IHC
S-6811	11564	SYNCHRONIZER	542 FORD,DODGE,IHC
S-6693	11580	SYNCHRONIZER	540 DODGE,IHC
S-6695	11582	SYNCHRONIZER	435 DODGE
S-6825	11780	MAINSHAFT	7550,7590-IHC
S-6826	11808	COUNTERSHAFT	542 DODGE,GM
S-6701	11824	MAIN DRIVE GEAR	7550,7590 GM,DODGE
S-6704	11953	MAIN DRIVE GEAR	435-DODGE
S-5975	13082	MAINSHAFT	435-FORD
S-6831	13185	MAINSHAFT	435-FORD
S-6832	13259	LOW GEAR & STOP	7550,7590-GM,IHC,DODGE
S-6710	13288	MAINSHAFT	435-FORD,DODGE
S-6711	13527	COUNTERSHAFT	435-FORD,DODGE
S-5855	13528	M.S. 3RD GEAR	435-FORD,DODGE
S-3613	13639	RING AND PIN ASSY	542-FORD,GM,DODGE,ALUMINUM
S-6714	13647	SYNCHRONIZER	445,4590-IHC,DODGE
S-6835	13648	SYNCHRONIZER	541,542-IHC,DODGE,IHC-T35,36,495,496,698,699

LATEST ADDITIONS TO OUR CATALOG

EXCEPT WHERE SPECIFIED, ALL PARTS SUPPLIED ARE S&S/NEWSTAR. USE OF OTHER MANUFACTURERS' NAMES, PART NUMBERS, OR TRADEMARKS ARE FOR INFORMATIONAL AND IDENTIFICATION PURPOSES ONLY.



REPLACEMENT GEARS AND PARTS

APPLICATION: NEW PROCESS TRANSMISSIONS

TRANSMISSION

NEWSTAR NUMBER	REPLACEMENT FOR PART NUMBER	DESCRIPTION	APPLICATION - MODEL
S-6836	13649	SYNCHRONIZER	7550,7590-IHC
S-6715	13678	MAIN DRIVE GEAR	542-DODGE
S-6720	13779	MAIN DRIVE GEAR	208-FORD,DODGE
S-6839	13948	MAIN DRIVE GEAR	208-GM
S-6727	15112	MAIN DRIVE GEAR	208-GM
S-6730	15307	SPROCKET	208-FORD,GM,DODGE
S-3584	15328	MAIN DRIVE GEAR	435-FORD
S-6738	15588	C.S. DRIVE GEAR	542-FORD,GM
S-6742	15592	C.S. 4TH GEAR	542-FORD,GM
S-6743	15593	M.S. 3RD GEAR	542-FORD
S-6746	15596	C.S. 3RD GEAR	542-FORD
S-6842	15746	MAIN DRIVE GEAR	542-GM
S-6784	17095	RETAINER	435-GM
S-3228	91177	M.S. 4TH GEAR	540,541-GM,IHC,DODGE
S-6754	91197	C.S. DRIVE GEAR	540-DODGE
S-6844	91198	C.S. 3RD & 4TH GEAR	540,541-FORD,GM,IHC,DODGE
S-6756	91226	FORK ASSEMBLY	540,541-GM,IHC,DODGE
S-4106	91383	M.S. 1ST GEAR	540,541-GM,IHC,DODGE,FORD
S-C725	91458	REAR BRG RETAINER, C.S.	MODEL 540
S-6845	91568	SLIDING CLUTCH	540-FORD,GM,IHC,DODGE
S-6846	91581	SLIDING CLUTCH	540,541-FORD,GM,IHC,DODGE
S-6759	91677	FORK ASSEMBLY	540,541,542-FORD,GM,IHC,DODGE
S-4641	91888	EMER BRAKE BAND	435-IHC,GM,DODGE
S-7715	91967	C.S. DRIVE GEAR	540-DODGE,IH,FORD,GM
S-6850	92508	M.S. 1ST GEAR	541,542-GM,DODGE
S-6852	92517	C.S. 4TH GEAR	541,542-FORD,GM,IHC,DODGE
S-3229	92683	REV. IDLER GEAR	540,541-FORD,GM,IHC,DODGE
S-6853	92687	C.S. DRIVE GEAR	541,542-FORD,GM,IHC,DODGE
S-6762	92708	OUTER RING	540,541,542-FORD,GM,IHC, DODGE,IHC-T495,496,698,699
S-6854	92736	REV. IDLER GEAR	541,542-FORD,GM,IHC,DODGE
S-6855	93549	INSERT - QTY PKG 25	435,542-FORD,GM,IHC,DODGE
S-6856	93653	M.S. 3RD GEAR	540-FORD,GM,IHC,DODGE
S-5240	93654	M.S. 2ND GEAR	540,541-FORD,GM,IHC,DODGE
S-6768	93662	MAIN DRIVE GEAR	541,542-GM
S-6770	93722	MAIN DRIVE GEAR	540,541-DODGE
S-4108	93824	C.S. DRIVE GEAR	540,541-GM,DODGE,FORD
S-5484	93966	FORK ASSEMBLY	540,541,542-FORD,GM,IHC,DODGE
S-2708	94462	SLIDING CLUTCH	541,542-IHC,DODGE,GM,IHC-T35,36,495,496,698,699
S-9176	AX94906	LEVER BOOT KIT	435,542
S-4559	95286	MAIN DRIVE GEAR	541,542-FORD
S-6857	95288	MAIN DRIVE GEAR	541,542-FORD
S-6858	95553	MAIN DRIVE GEAR	540,541-GM
S-7275	95708	M.S. 3RD GEAR	435-FORD,GM,IHC,DODGE
S-7276	95723	MAIN DRIVE GEAR	435-FORD
S-7278	95726	M.S. 2ND GEAR	435-FORD,GM,IHC,DODGE
S-6859	95727	RING AND PIN	435-FORD,GM,IHC,DODGE
S-6779	95733	COUNTERSHAFT	435-FORD,GM,IHC,DODGE
S-6780	95734	RETAINER	435-FORD,GM,IHC,DODGE
S-6782	95747	FORK ASSEMBLY	435-IHC,DODGE,GM
S-3223	95761	MAIN DRIVE GEAR	540-DODGE
S-6054	95849	CLUTCH GEAR	435-FORD,GM,IHC,DODGE
S-6783	95868	RETAINER	540,541-DODGE,GM
S-9368	95961	BUSHING	FOR 95979 REV. IDLER GEAR
S-7280	95979	REV IDLER GEAR	435-DODGE, FORD, IHC
S-7281	95991	MAINSHAFT	435-IHC

LATEST ADDITIONS TO OUR CATALOG

EXCEPT WHERE SPECIFIED, ALL PARTS SUPPLIED ARE S&S/NEWSTAR. USE OF OTHER MANUFACTURERS' NAMES, PART NUMBERS, OR TRADEMARKS ARE FOR INFORMATIONAL AND IDENTIFICATION PURPOSES ONLY.

REPLACEMENT GEARS AND PARTS

APPLICATION: NEW PROCESS TRANSMISSIONS

NEW STAR NUMBER	REPLACEMENT FOR PART NUMBER	DESCRIPTION	APPLICATION - MODEL
S-7282	95993	MAIN DRIVE GEAR	435-IHC
S-6784	96003	RETAINER	435-GM
S-6860	96004	MAIN DRIVE GEAR	435-GM
S-7283	96009	MAINSHAFT	435-GM,DODGE
S-6861	96354	MAIN DRIVE GEAR	435-GM
S-7284	96372	MAIN DRIVE GEAR	435-FORD
S-3660	96373	RETAINER	435-FORD
S-A037	96828	BEARING	435-IHC,DODGE
S-7822	96829	CLUTCH GEAR	435-IHC,DODGE
S-6863	96914	M.S. 3RD GEAR	435-DODGE
S-6864	96969	INSERT - QTY PACK 25	435-IHC,GM,FORD,DODGE
S-6865	96986	CLUTCH GEAR W/BEARING	435-IHC,DODGE
S-7285	97121	M.S. LOW GEAR	435-FORD,GM,DODGE,IHC
S-6866	97348	MAINSHAFT NUT	435,540,541-GM,IHC,DODGE
S-6787	97419	MAIN DRIVE GEAR	541,542-GM
S-3746	97562	SLIDING CLUTCH	542-FORD,GM,DODGE,IHC
S-6790	97588	SHAFT	REV BOX 540
S-6791	97591	REV. IDLER SHAFT	540 REVERSE BOX TIMBERJACK,TOW MOTOR
S-6793	97601	COUNTERSHAFT	540-542,REVERSE BOX
S-6868	97672	MAIN DRIVE GEAR	435-DODGE
S-6869	97753	MAINSHAFT	540,541-GM,IHC,DODGE
S-6870	97754	MAINSHAFT	540,541-GM
S-3586	97844	CLUTCH GEAR	542-FORD,GM,IHC,DODGE
S-4279	97848	MAINSHAFT	542-GM,IHC,DODGE
S-6872	97978	M.S. 2ND GEAR	542-FORD,IHC,DODGE
S-6873	97999	M.S. 3RD GEAR	542-FORD,IHC,DODGE
S-6874	99003	GEAR-MAINSHAFT	542-FORD, DODGE
S-6878	99104	REV. IDLER GEAR	445,4590-GM,IHC,DODGE
S-6805	99285	GEAR W/O BUSHING	75,507,590
S-6884	99291	SLIDING CLUTCH	7550,7590-GM,IHC,DODGE
S-6885	99292	CLUTCH GEAR	7550,7590-GM,IHC,DODGE
S-6886	99511	MAINSHAFT	542-FORD
S-8714	99528	SHIFT COVER ASSY	—
S-7287	99705	MAIN DRIVE GEAR	542-IHC
S-6812	99754	MAIN DRIVE GEAR	NP-540,542 REVERSE BOX
S-9747	T27	BEARING & SEAL KIT	540,541,542 EARLY
S-9605	T29	BEARING & SEAL KIT	541,542
S-9606	T29B	BEARING & SEAL KIT	542 FORD LATE MODELS
S-7216	T127	BEARING & SEAL KIT	435 FORD
S-8819	T127B	BEARING & SEAL KIT	435 GM
S-6819	GS-435	GASKET SET	435
S-6820	GS-540	GASKET SET	540,541,542
S-8937	GS-540-RB	GASKET SET	540
S-A479	SP-208-50	SMALL PARTS KIT	208
S-6159	SP-277-50	SMALL PARTS KIT	540,541
S-6159	SP-283-50	SMALL PARTS KIT	541,542
S-3884	SP-291-50	SMALL PARTS KIT	435
S-5853	SP-310-50	SMALL PARTS KIT	542

LATEST ADDITIONS TO OUR CATALOG

EXCEPT WHERE SPECIFIED, ALL PARTS SUPPLIED ARE S&S/NEWSTAR. USE OF OTHER MANUFACTURERS' NAMES, PART NUMBERS, OR TRADEMARKS ARE FOR INFORMATIONAL AND IDENTIFICATION PURPOSES ONLY.



GENUINE GEARS AND PARTS

APPLICATION: NEW PROCESS TRANSMISSIONS

TRANSMISSION

GENUINE PART NUMBER	DESCRIPTION	GENUINE PART NUMBER	DESCRIPTION
13068	SNAP RING	16448	RANGE FORK -- NV242,244,249
13368	LOCK NUT -- HEX	16449	SHIFT RAIL
13683	REAR CASE HALF	16472	FORK
13695	WASHER-YOKE -- RUBBER	16488	BEARING
13725	SEAL-O RING	16518	YOKE NUT WASHER -- NP24 1
13726	O-RING -- PLASTIC	16526	POPPET SPRING
13733	BRACKET & PIN ASSY	16544	SWITCH
13735	FORK	16550	PLANETARY ASSY
13795	PAD-RANGE FORK -- PLASTIC	16569	RETAINING RING
13797	DRIVE CHAIN	16624	CHAIN
13798	CHAIN	16667	REAR CASE ASSY -- NP247/249
13816	SPRING	16686	GEROTOR PUMP ASSY -- NP246/24
13955	RETAINING RING	16690	BEARING
13992	LOCK NUT	16692	SPEEDO GEAR -- NP247/249
14057	MAINSHAFT ASSY	16699	STUD -- REQ.6
15079	CASE HALF	16706	RETAINING RING
15107	SCREW -- REQ.3	16760	INPUT GEAR ASSY
15142	WASHER	16779	CENTER PAD
15166	FRONT CASE HALF	16962	SPRING
15307	DRIVE SPROCKET	17025	MODE FORK ASSY
15372	SHIFT FORK	17071	SPRING
15486	OIL PUMP HOUSING ASSY	17118	INPUT GEAR ASSY
15516	RETAINING RING	17167	CHAIN ASSEMBLY
15547	SYN STOP RING	17174	POPPET SPRING
15578	OIL SEAL-SPLINE	17237	MODE FORK ASSY
15579	LOCK NUT-HEX	17238	FRONT CASE ASSY -- NP249
15608	CASE HALF-FRNT	17253	LEVER & GROMMET
15618	RANGE SHIFT FORK	17268	MAINSHAFT
15621	FORK LOCK ASSY	17393	REAR CASE ASSY.
15635	SHIFT FORK RANGE FORK -- 15618	17458	CASE ASSY -- REAR
15715	O-RING SEAL	17459	REAR RETAINER
15866	PAD KIT-SHIFT FORK	17462	EXTENSION ASSY
16027	INPUT BRG ASSY	17474	STUD -- REQ.6
16066	SPROCKET -- NP241D	17477	EXTENSION ASSY
16112	SLIDING CLUTCH -- LOCK/UNLOCK	17483	LOCK PLATE
16129	REAR CASE HALF	17521	SUPPORT SLEEVE -- NP241
16205	SNAP RING	17543	RANGE FORK ASSY -- NP241/271
16209	OIL PUMP ASSY	17556	SPRING
16214	OIL SEAL	17711	DRIVE SPROCKET
16215	TUBE	17772	HUB-SYNCHRO
16217	OIL SCREW	17773	SLEEVE-SYNCHRO
16218	CONNECTOR TUBE	17779	BLOCKER RING
16243	RETAINING RING	17790	MODE FORK ASSY
16244	INPUT SHAFT ASSY.	17813	SPROCKET -- NP241
16247	DRIVE SPROCKET ASSY.	17814	DRIVE SPROCKET -- NP241
16249	FRONT OUTPUT ASSY.	17822	INPUT GEAR ASSY
16252	OIL TUBE	17823	SYNCHRO SLEEVE
16254	CASE HALF -- REAR	17824	RANGE SLEEVE
16255	RETAINER-REAR	17833	RANGE FORK -- NP231/241/247/249T
16262	SPEED SENSOR	17868	PLANETARY ASSY -- NP231/233/247/249
16267	MODE FORK ASSY	17869	PLANETARY ASSY
16273	PLANETARY ASSY	17880	YOKE ASSEMBLY
16276	SPEEDO GEAR	17881	FRONT OUTPUT SHAFT
16347	OIL SCREEN	17949	INPUT GEAR -- NP231
16349	REAR RETAINER ASSY.	17953	INPUT GEAR -- NP241
16359	REAR RETAINER	17954	INPUT GEAR -- NP241
16365	DRIVE SPROCKET	17978	INPUT GEAR ASSY
16370	OUTPUT FLANGE -- NP218/241/208GM	17980	INPUT GEAR ASSY
16374	FLANGE & SLINGER ASSY -- NP241	17982	SLEEVE
16418	CHAIN	17991	RANGE FORK ASSY
16432	MODE CLUTCH SLEEVE	17993	MOTOR -- NP243TC
16437	THRUST WASHER	19005	CASE ASSEMBLY
16442	BRG.RETAINER RING	19014	MAINSHAFT
16447	SPRING CUP	19019	INPUT GEAR ASSY

GENUINE GEARS AND PARTS

APPLICATION: NEW PROCESS TRANSMISSIONS

GENUINE PART NUMBER	DESCRIPTION	GENUINE PART NUMBER	DESCRIPTION
19043	DRIVE SPROCKET	25847	FRT OUTPUT SHAFT ASSY
19055	FONT OUTPUT YOKE ASSY -- NP247/249	25896	INPUT GEAR ASSY -- NP261
19060	OIL SEAL	25900	REAR CASE ASSEMBLY
19061	INPUT GEAR ASSY	25902	TONE WHEEL
19076	SHIFT RAIL	25904	PUMP ASSY-GEROTOR
19114	RANGE SHIFT SLEEVE -- NP241TC	26081	OUTER RING
19129	OIL SEAL -- NP242	26082	MODE SLEEVE
20360	INPUT GEAR ASSY	26162	VENT ASSEMBLY
20480	MAINSHAFT	26234	RETAINING RING
20938	SYNCHRO RING	26331	BEARING
20939	DRIVE SPROCKET	26343	CASE HALF-REAR
21400	RANGE SLEEVE	26345	REAR CASE HALF ASSY.
21635	RING-MIDDLE -- NP261/263	26542	RANGE FORK ASY
21653	REAR CASE HALF ASSY -- NP241	26617	FRONT CASE HALF ASSY
21966	DRIVE/DRIVEN SPROCKET	26618	FLANGE ASSY.
21967	CHAIN	26675	RETAINER-REAR
22013	SECTOR ASSY	26677	VISCOUS COUPLING ASSY
22398	FILL PLUG	26747	SHIFT LEVER ASSY.
22440	BEARING	26933	REAR RETAINER ASSY
22441	OIL SEAL -- INPUT	26945	SECTOR ASSY.
22446	BOLT -- REQ.3	26946	HUB
22447	FRONT OUTPUT SHAFT -- NP136/236	26958	LEVER ASSY.
22449	TONE WHEEL	26973	REAR CASE HALF ASSY -- NP247TC
22451	RETAINING RING	26976	SNUBBER
22452	FRONT OUTPUT OIL SEAL -- NP136/2	27024	SUPPORT OIL SEAL
22461	CLUTCH LEVER INSERT -- NP246	27025	SECTOR SUPPORT ASSY.
22479	INNER DRUM RET RING -- NP241/247	27135	THRUST WASHER
22495	SNAP RING -- NP126/136/226/236/2	27297	FRONT CASE HALF ASSY
22500	CHAIN	27303	STUD -- REQ.6
22501	BEARING	27313	REAR OUTPUT PLUG
22506	RETAINING RING	27428	FLANGE ASSY.
22507	REAR OUTPUT OIL SEAL -- NP24	27719	MAINSHAFT
22512	SPEED SENSOR	27720	CLUTCH GEAR
22918	SCREW	27721	DRIVE SPROCKET HUB
23733	FRONT 1/2 CASE ASSY -- NP246	27722	INNER CONE
23739	SPROCKET	27745	PRESSURE PLATE -- NP136/236
23748	SHIFT RAIL	27747	CLUTCH PLATE
23989	SCREW ASSEMBLY	27756	FORK ASSY.
24257	INPUT GEAR ASSY.	27758	SECTOR BOLT
24262	MODE FORK ASSY.	27761	RANGE SLEEVE
24272	FRONT OUTPUT SHAFT	27873	ENCODER ASSY -- GEAR MOTOR
24273	CHAIN	27882	PLANETARY ASSY
24276	REAR CASE HALF ASSY.	27924	SCREEN
24361	BRACKET	27925	TUBE
24668	MODE FORK ASSY	27926	OIL SEAL
24854	OUTER DRUM -- NP136/236/246	27930	DAMPER PLATE ASSY.
25079	MAINSHAFT -- NP246	28508	RAIL
25317	LEVER ASSEMBLY	28650	BOLT-SUB ASSY. -- REQ.17
25446	DRIVE SPROCKET	29010	PRESSURE PLATE -- NP136 /246
25457	GERODISC ASSY	29295	ROTARY ACTUATOR
25464	RETAINING RING	29733	OUTPUT ASSY -- FRONT
25499	TUBE	29832	OUTER DRUM ASSY -- NP126/226
25500	CONNECTOR	29839	CLUTCH RETURN SPRING
25501	TUBE	29840	OUTER BEARING SUPPORT PLATE
25502	SCREEN	29939	INNER DRUM -- NP136/236/241J
25503	SEAL-ORING	30079	ENCODER ASSY.
25504	RETAINING RING	30138	FRNT OUTPUT OIL SEAL
25519	PUMP ASSEMBLY	30154	FRONT CASE ASSY.
25524	CLUTCH GEAR	30412	FILL DRAIN PLUG
25552	SPROCKET HUB	30597	FRONT CASE HALF ASSY
25735	BRACKET	30603	CASE ASSY -- REAR
25795	RANGE SLEEVE	30959	FRONT CASE HALF ASSY
25832	FRONT OUTPUT SHAFT	30961	REAR CASE ASSEMBLY
25836	LOCKING CLUTCH	30965	CHAIN -- NPT247

GENUINE GEARS AND PARTS

APPLICATION: NEW PROCESS TRANSMISSIONS

TRANSMISSION

GENUINE PART NUMBER	DESCRIPTION	GENUINE PART NUMBER	DESCRIPTION
31023	INPUT GEAR ASSEMBLY	45528	SECTOR ASSY.
31268	SPROCKET – NP136/236/241J	45541	SECTOR ASSY.
31269	SPROCKET	45661	SYNCHRO HUB
31270	RANGE FORK ASSY – NP236	45731	INPUT GEAR ASSY.
31534	CHAIN	46230	REAR CASE ASSY – NP247
31653	MAINSHAFT	46234	SECTOR ASSY.
31921	REAR RETAINER ASSY	46903	FRONT CASE 1/2
32171	FRONT CASE HALF ASSY	47397	APPLY PLATE
32177	INPUT GEAR ASSY	47406	ACTUATOR
32818	ACTUATOR	47472	APPLY PLATE
33261	LUBRICATION PUMP	47473	APPLY PLATE
33403	SYNCHRO ASSY.	47641	INNER DRUM ASSY
33982	OIL SEAL-INPUT	48056	ACTUATOR
34181	PILOT POINT SCREW	48500	LEVER ASSY.
36153	RANGE SLEEVE	48508	MAINSHAFT – NP136/236
37156	OIL TUBE	48708	INNER DRUM ASSY
37424	PLANETARY ASSY – DEHYDRATED NP	48714	MAINSHAFT
37425	PLANETARY ASSY – DEHYDRATED NP	49673	MODULE
37798	INPUT RETANER	52745	MIDDLE RING
37799	EXTENSION ASSY	61575	SCREW – REQ.2
37803	REAR EXTENSION ASSY	95472	MAGNET
37810	FRONT OUTPUT SHAFT	442934	ROLL PIN
37849	SECTOR ASSY	2436163	WASHER
37902	FRONT CASE HALF ASSY	4338017	3RD GEAR – MAINSHAFT
38207	INPUT GEAR ASSY	4338031	NEEDLE BEARING -IDLER GR- M/S
38247	MAINSHAFT	4338079	NEEDLE BEARING FOR IDLER GEAR
38666	FLANGE ASSY.	4338275	SHIM/SPACER – 1.37-1.39
38800	BALL BRG ASSY	4338277	SHIM/SPACER – 1.55-1.57
38984	DRIVE SPROCKET	4338281	SHIM/SPACER – 1.91-1.93
38985	CHAIN	4446061	SYNCHRO RING – 3/4/5TH
39961	DRIVE SPROCKET HUB	4461047	CLUTCH PLATE
39969	MODE HUB	6101526	BOLT – HEX FLANGE HEAD REQ.17
40877	SWITCH – 5 POSITION	89331A	SNAP RING VARIOUS
40910	SPROCKET-50-40T	96711B	RING
40966	LEVER ASSEMBLY	99088C	RETAINING RING
41011	SPROCKET		
41061	SYNCHRO ASSY.		
41288	SPACER		
41605	MODE FORK ASSY.		
41818	RANGE FORK ASSY.		
41819	RANGE FORK – NP263		
42007	YOKE ASSEMBLY		
42202	RETAINER ASSY		
42410	FRONT CASE ASSY		
42473	RANGE FORK ASY		
42615	MAINSHAFT ASSY		
42705	SECTOR ASSY.		
42740	INPUT GEAR ASSY		
42887	SECTOR SHAFT SUPPORT ASSY.		
42996	MAINSHAFT – NP136/236/246 GM#88		
43091	SECTOR ASSY.		
43549	DAMPER ASSY.		
43550	LINEAR DAMPER		
43681	RANGE SLEEVE		
43682	RANGE FORK ASSY		
44039	BOLT – M8X1.25X.57L		
44243	HEX FLANGE SCREW		
44574	HEX BOLT		
44920	MOTOR		
44926	INPUT GEAR ASSY		
44928	MOTOR		
45109	1. PIECE CLUTCH GEAR HUB – NP236		
45207	MAINSHAFT		
45244	PLANETARY CARRIER ASSY.		

REPLACEMENT GEARS AND PARTS

APPLICATION: NEW VENTURE TRANSMISSIONS

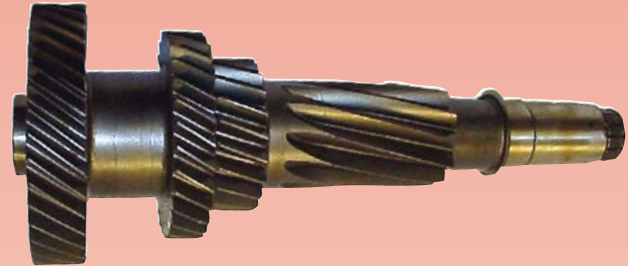
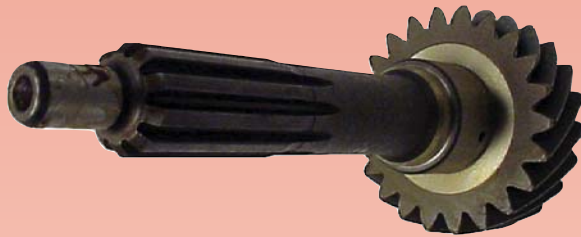

NEW STAR NUMBER	REPLACEMENT FOR			DESCRIPTION	MODEL NUMBER
	NEW VENTURE NUMBER	GM NUMBER	CHRYSLER NUMBER		
S-13369	16780	15635260	—	OIL SEAL	4500
S-13418	16795	15635232	—	WASHER	4500
S-13419	16797	15635252	—	WASHER	4500
S-D491	16799	15635278	—	GEAR-MAINSHAFT OD	4500
S-13432	16846	15635197	—	BEARING CAP	4500
S-A592	16999	12548339	4637798	M.S. 5TH GEAR	4500
S-A593	17272	—	4637704	C.S. DRIVE GEAR	4500
S-14172	17078	15635219	4637718	SYNCHRO RING	4500
S-D492	17284	15637274	4637719	SYNCHRO RING	4500
S-D493	17293	15637281	4637730	GEAR-MAINSHAFT 3RD	4500
S-D494	17298	—	—	USE 47685	4500
S-D495	17306	15637291	4637861	SLIDER (SYNCHRO SLEEVE)	4500
S-D496	17307	15637298	4637792	SYNCHRO RING	4500
S-D497	17308	15637292	—	REVERSE GEAR, COUNTERSHAFT	4500
S-D498	17309	—	4637760	REVERSE GEAR, MAINSHAFT	4500
S-A842	17310	15637293	—	INPUT SHAFT	4500
S-D499	17311	—	4637772	INPUT SHAFT	4500
S-D500	17317	15637296	—	GEAR, COUNTERSHAFT OD	4500
S-A843	17318	12548338	4637786	C.S. 5TH GEAR	4500
S-D501	17330	—	4637703	GEAR, COUNTERSHAFT 3RD	4500
S-A940	17507	15665238	—	RETAINER W/SEAL	4500
S-14184	17582	12548337	4723003	SYNCHRONIZER	4500
S-14191	18132	12540387	—	SYNCHRONIZER	4500
S-A579	18160	—	—	USE 25356	4500
S-14195	18172	—	05003210AA	BUSHING	4500
S-D502	18161	—	4741543	FRONT RETAINER	4500
S-A840	18164	12473260	4741551	M.S. 5TH GEAR	4500
S-D503	18321	12542866	—	SLIDER (SYNCHRO SLEEVE)	4500
S-D504	18412	12542865	4740824	SYNCHRO ASSEMBLY	4500
S-D505	18918	12382792	4874369	M.S. 3RD GEAR	4500
S-D506	18922	12542867	—	GEAR, MAINSHAFT 3RD	4500
S-D507	18923	12473258	4723009	REVERSE GEAR	4500
S-13440	19016	5714224	—	OIL SEAL	4500
S-A578	20018	12548483	—	INPUT SHAFT	4500
S-13431	20231	12548394	4778216	SHIFT RAIL	4500
S-A844	21313	15637289	4874370	CLUTCH RING	4500
S-14294	21359	12549350	5013188AA	MAINSHAFT	3500
S-14298	21505	12382813	4882541	BEARING	4500
S-A595	22608	12382796	4637700	COUNTERSHAFT	4500
		12548477	4874836		
S-D508	22657	12382834	—	COUNTERSHAFT	4500
S-14331	22787	—	—	WASHER	4500
S-14336	22803	—	—	GEAR	4500
S-14370	23267	—	—	REV IDLER GEAR	4500
S-13105	23712	12548980	4773011	GEAR-MAINSHAFT	4500

LATEST ADDITIONS TO OUR CATALOG

EXCEPT WHERE SPECIFIED, ALL PARTS SUPPLIED ARE S&S/NEWSTAR. USE OF OTHER MANUFACTURERS' NAMES, PART NUMBERS, OR TRADEMARKS ARE FOR INFORMATIONAL AND IDENTIFICATION PURPOSES ONLY.



REPLACEMENT GEARS AND PARTS

APPLICATION: NEW VENTURE TRANSMISSIONS

TRANSMISSION

NEWSTAR NUMBER	REPLACEMENT FOR			DESCRIPTION	MODEL NUMBER
	NEW VENTURE NUMBER	GM NUMBER	CHRYSLER NUMBER		
S-11890	24024	12382857	4897881AA	SYNCHRO RING	4500
S-D510	25330	12382817	—	MAINSHAFT	4500
S-D512	25332	12382819	—	MAINSHAFT	4500
S-A579	25356	—	4882358	INPUT SHAFT	4500
S-D513	27170	12382816	—	MAINSHAFT	4500
S-D514	27171	—	4882317	MAINSHAFT	4500
S-D515	27173	—	4882318	MAINSHAFT	4500
S-D516	27176	—	4741468	MAINSHAFT	4500
S-A341	23049683	—	—	INPUT SHAFT	3500
S-A342	23049687	—	—	CLUSTER	3500
S-A520	SP-3500-50	—	—	SMALL PARTS KIT	3500
S-A521	SP-4500-50	—	—	SMALL PARTS KIT	4500
S-9823	T4500BK	—	—	BEARING & SEAL KIT	4500
S-9826	T308R	—	—	BEARING & SEAL KIT W/CAGED NEEDLE BEARINGS	4500
S-9820	T235	—	—	BEARING & SEAL KIT 1ST DESIGN "88-89"	3500
S-9822	T235B	—	—	BEARING & SEAL KIT 3RD DESIGN "91 & UP"	3500



LATEST ADDITIONS TO OUR CATALOG

EXCEPT WHERE SPECIFIED, ALL PARTS SUPPLIED ARE S&S/NEWSTAR. USE OF OTHER MANUFACTURERS' NAMES, PART NUMBERS, OR TRADEMARKS ARE FOR INFORMATIONAL AND IDENTIFICATION PURPOSES ONLY.

GENUINE GEARS AND PARTS

APPLICATION: NEW VENTURE TRANSMISSIONS

GENUINE PART NUMBER	DESCRIPTION	GENUINE PART NUMBER	DESCRIPTION
15054	NV5600-PLUG & WASHER ASSY	18834	M/S 1ST/2ND RING-CENTER
15207	RETAINER RING	18847	SHIFT SHAFT SPRING
16781	OIL SEAL	18851	MAINSHAFT
16794	RETAINER RING	18863	3/4TH SHIFT LUG
16797	WASHER	18870	BUSHING
16801	M/S BRG CUP	18872	BOLT
16802	M/S BRG CONE	18921	CLUTCH RING
16803	CAGE BEARING	18948	SHIFT LEVER ASSY
16804	NV500-NEEDLE BRG	18949	SPRING
16816	REV SHIFT RAIL	18960	MAGNET
16818	SPACER	20013	SHIFT SHAFT SPRING
16853	SHIM KIT FOR C/S REAR BEARING	20148	SPACER ASSY
16872	BIAS PLUNGER 1ST DESIGN	20204	BEARING
16874	THRUST WASHER-OD GR	20234	HUB
16875	RETAINER RING-1/2ND	20652	BRASS BLOCKING RING
16899	M/S NUT IN SMALL PARTS KIT	20859	MAINSHAFT
17062	SEAL	20860	MAINSHAFT
17063	OUTPUT SEAL	20870	MAINSHAFT 5TH GEAR
17137	SEAL	20871	MAINSHAFT 5TH GEAR
17146	SPRING-SHIFT LEVER	20902	MAIN DRIVE GEAR
17165	BEARING RETAINER RING (4500)	20911	COUNTERSHAFT CLUSTER
17181	DISC SPRING WASHER (4500)	20950	SYNCHRO RING
17200	C/S SPACER	20952	SHIM
17270	COUNTERSHAFT FRONT CUP	20953	SHIM
17271	DRIVE GEAR, C.S.	20954	SHIM
17273	C/S FRONT BEARING CUP	20955	SHIM
17274	C/S REAR BEARING CONE	20956	SHIM
17275	C/S REAR BEARING CUP	20957	SHIM
17288	1ST/2ND SHIFT RAIL	20958	SHIM
17289	SYNCHRO STOP	20959	SHIM
17291	CLUTCH GEAR	20960	SHIM
17301	HUB	20961	SHIM
17324	SHIFT FORK 3/4TH	20962	SHIM
17327	SHIFT LEVER ASSY	20963	SHIM
17346	SPRING	20964	SHIM
17420	SHIFT LEVER BOOT	20967	SHIM
17480	EXPANSION PLUG	20968	SHIM
17499	KEY	20969	SHIM
17505	CONE & BEARING	20970	SHIM
18105	PIN-SHIFT SHAFT DETENT LOCK	20971	SHIM
18120	SPRING-SHIFT SHAFT DETENT	20972	SHIM
18126	BUSHING-REAR EXT	20973	SHIM
18127	BUSHING-REAR EXT."S"	20974	SHIM
18131	1/2 SYNCH ASSY(3500)	20975	SHIM
18132	M/S 5TH/REV SYN ASSY	20980	MAINSHAFT 1ST GEAR
18165	DISC SPRING WASHER (4500)	20982	MAINSHAFT 2ND GEAR
18166	NUT-M/S 5TH CHRYSLER V10 DIE	20987	SNAP RING
18291	M/S REV SYNC RING	21241	CONE
18296	WASHER/WAVE SPRING	21351	THRUST WASHER
18297	WASHER	21503	NEEDLE ROLLER BEARING
18298	RETAINER RING	21504	NEEDLE ROLLER BEARING
18303	1ST/2ND SHIFT FORK (NV4500)	21552	BUSHING
18377	RETAINING RING	21553	SYNCHRO
18453	SHIFT LEVER CAP	21901	SEAL
18472	REV GEAR ASSY(3500)	22142	RETAINER
18573	REV IDLER SHAFT	22303	THRUST WASHER
18575	REV IDLER GEAR	22328	CASE
18576	THRUST WASHER	22414	RETAINER
18585	5TH GEAR	22730	CUP
18588	NEEDLE BEARING ASSY	22732	HOUSING ASSY
18643	NEEDLE BEARING	22735	CUP
18740	CLUTCH FORK PIVOT ASSY	22737	REAR HOUSING ASSY
18751	SHIFT SHAFT PLUNGER (3500)	22740	BUSHING
18796	BEARING	22747	INPUT SHAFT

GENUINE GEARS AND PARTS

APPLICATION: NEW VENTURE TRANSMISSIONS

TRANSMISSION

GENUINE PART NUMBER	DESCRIPTION	GENUINE PART NUMBER	DESCRIPTION
22748	INPUT SHAFT ASSY	25863	SEAL
22752	INPUT CONE	26166	COUNTERSHAFT
22756	GEAR	26177	ACTUATOR ASSY
22761	SYNCHRO RING	26264	SHIM
22768	RETAINING RING	26265	SHIM
22769	BEARING	26266	SHIM
22788	CONE ASSY	26267	SHIM
22799	SYNCHRO ASSY	26268	SHIM
22811	INPUT SHIFT RAIL	26269	SHIM
22813	SOCKET	26270	SHIM
22817	SHIFT LEVER	26271	SHIM
22818	BLOCKER	26274	SHIM
22825	NV5600-3RD/4TH & 5TH /6TH ACT.	26280	SHIM
22826	SHIFT LUB	26282	SHIM
22842	SHIFT LUG	26283	SHIM
22844	BRACKET	26284	SHIM
22863	RETAINER ASSY	26285	SHIM
22866	SLEEVE	26286	SHIM
22869	REVERSE SHAFT	26287	SHIM
22872	SPACER	26288	SHIM
22873	IDLER GEAR	26289	SHIM
22880	REV SYN ASSY	26290	SHIM
22883	LOCK RING	26291	SHIM
22884	SHIFT FORK	26292	SHIM
22886	REV GEAR ASSY	26293	SHIM
22889	THRUST WASHER	26294	SHIM
22890	BEARING ASSY	26295	SHIM
23079	HOUSING	26296	SHIM
23193	SPACER	26297	SHIM
23195	SPACER	26298	SHIM
23211	THRUST WASHER	26299	SHIM
23266	REV IDLER SHAFT	26300	SHIM
23319	PIN SHIFT SHAFT	26373	SHIFT LEVER ASSY
23326	SHIFT SHAFT SOCKET	26375	SHIFT LEVER ASSY
23675	SPEED WHEEL	26376	SHIFT LEVER ASSY
23908	BEARING	26435	SHIM
23915	BEARING	26439	SHIM
23924	BEARING	26441	SHIM
23931	WASHER	26442	SHIM
24741	RETAINING RING	26443	SHIM
24742	RETAINING RING	26445	SHIM
24745	RETIANING RING	26447	SHIM
24746	RETAINING RING	26459	CLIP
24747	RETAINING RING	26528	SPRING
24748	RETAINING RING	26703	FORK ASSY
24749	RETAINING RING	27339	SLEEVE
24750	RETAINING RING	27340	SLEEVE
24753	RETAINING RING	27664	BOLT
24754	RETAINING RING	27874	SHIFT LEVER ASSY
24785	BEARING CONE	27963	SHIFT LEVER ASSY
24786	BEARING CUP	27990	SHIFT SHAFT
24788	CONE ASSY	27992	RAIL
24789	BEARING CUP	28042	SHIFT FORK
24792	C/S CTR.BRG CONE ASSY.(5600)	28043	SHIFT FORK
24793	REAR BEARING CUP	28044	SHIFT FORK
24796	REAR GEAR CONE ASSY	28045	SHIFT FORK
24798	BEARING CUP	28046	SHIFT FORK
25250	CAM	28224	SEAL
25354	MAIN DRIVE GEAR	28437	SHIFT FORK
25377	SHIFT LUG GATE	28648	INNER GUIDE
25413	SHIFT RAIL	28886	FORK
25619	SHIFT FORK	28887	FORK ASSY
25661	SHIFT FORK W/PLUNGER	30139	NUT
25833	IDLER BEARING	31286	SYNCHRO ASSY



GENUINE GEARS AND PARTS

APPLICATION: NEW VENTURE TRANSMISSIONS

GENUINE PART NUMBER	DESCRIPTION	GENUINE PART NUMBER	DESCRIPTION
31287	SYNCHRO ASSY	16811E	SHIM
31288	SYN ASSY	16811F	SHIM
33209	OIL SEAL	16811G	SHIM
33308	MAINSHAFT	16811H	SHIM
33325	MAINSHAFT	16811J	SHIM
33326	GEAR	16811L	SHIM
33328	MAINSHAFT	16811M	SHIM
33330	MAINSHAFT	16811N	SHIM
33979	ARM	16811R	SHIM
38183	GEAR ASSY	16811S	SHIM
38194	GEAR ASSY	16853A	SHIM
43265	SHIFT FORK ASSY	16853AY	SHIM
43277	SHIFT LUG GATE	16853AZ	SHIM
44548	NV5600-1/2/3/4/5/6/R EV. CONE	16853B	SHIM
44700	OUTPUT BEARING ASSY	16853BA	SHIM
45140	SLEEVE	16853BB	SHIM
45169	BALL BEARING ASSY	16853BC	SHIM
46046	SHIFT RAIL ASSY	16853BD	SHIM IN NV16853 KIT
99086	PIN WASHER	16853BE	SHIM IN NV16853 KIT
4269956	SEAL TRANS ADAPTOR	16853C	SHIM IN NV16853 KIT
5222757	DOWEL	16853E	SHIM IN NV16853 KIT
6022190	WASHER	20952X	NV5600/SHIM KIT-REV. GR.
8672123	KEY	26264X	NV5600/INPUT FRONT B RG.SHIM K
8672200	REV IDLER SHAFT	26282X	NV5600..C/S FRONT BR G. SHIM K
8672202	REV IDLER GEAR		
8672203	THRUST WASHER		
8672207	SPEEDO RING		
8672242	VENT		
8672265	OUTPUT SHAFT RETAINER		
8672266	OUTPUT SHAFT RETAINER		
8678297	OUTPUT SHAFT		
8678461	SHIFT LEVER ASSY		
8680487	NEEDLE BEARING ASSY		
8681415	SHIFT SHAFT DETENT PLUNGER		
8681609	RETAINER ASSY		
11513407	DOWEL PIN		
23049569	LAMP SWITCH ASSY		
23049718	SNAP RING		
23049719	SNAP RING		
23049720	SNAP RING		
23049721	SNAP RING		
23049722	SNAP RING		
23049723	SNAP RING		
23049724	SNAP RING		
23049725	SNAP RING		
23049727	SNAP RING		
23049728	SNAP RING		
23049746	SNAP RING-REV. IDLER		
23049747	SEGMENT		
23049790	SNAP RING		
23049797	PIVOT ASSY		
23049814	SEAL ASSY		
23049887	PLUG		
23049936	SNAP RING		
23049986	SNAP RING		
23049987	SNAP RING		
23049989	SNAP RING		
23049990	SNAP RING		
52103101	BRACKET		
53008550	CLIP		
16811A	SHIM		
16811B	SHIM		
16811C	SHIM		
16811D	SHIM		

REPLACEMENT GEARS AND PARTS

APPLICATION: TTC TRANSMISSIONS



TRANSMISSION

NEW STAR NUMBER	REPLACEMENT FOR		DESCRIPTION	APPLICATION MODEL
TTC NUMBER	INTERNATIONAL NUMBER			
S-10282	30-1-26	—	GEAR-MAINSHAFT	3000
S-A834	30-8-35	—	GEAR-MAINSHAFT	3000
S-11157	30-8-50	290131C1	GEAR-MAINSHAFT	3000
S-7036	30-8-78	—	GEAR-MAINSHAFT	3000
S-7037	30-35-96	—	INPUT SHAFT	3152
S-7436	30-35-97	—	INPUT SHAFT	3152A,3153,3153A
S-10283	30-37-14	—	SLEEVE	3000
S-5653	40-1-1	596346C1	C.S. GEAR DRIVE	CM40,ES42-5
S-5654	40-8-3	596354C1	M.S. 3RD GEAR	CM40
S-5663	40-8-5	596352C1	M.S. 2ND GEAR	CM40,ES42-5
S-A009	40-8-7	596341C1	M.S. 1ST GEAR	CM40
S-A295	40-8-9	596347C1	M.S. REV. GEAR	CM40
S-5662	40-8-11	596357C1	M.S. 3RD GEAR	4054-D
S-A329	40-8-17	1663640C1	M.S. 3RD GEAR	CM40
S-5623	40-35-12-1X	1651805C91	INPUT SHAFT	CM40
S-F012	40-35-18-1X	1666378C91	INPUT SHAFT	CM4054A,ES42-5A
S-A130	40-196-3	596353C1	C.S. 3RD GEAR	CM40
S-A101	40-196-5	596351C1	C.S. 2ND GEAR	CM40
S-5664	40-362-1	596358C1	MAINSHAFT	CM40
S-5657	40-465-11	1655543C1	CLUTCH COLLAR, 1ST & REV	CM40,ES42-5
S-5659	40-466-1	596355C1	M.S. CLUTCH GEAR, 4TH & 5TH	CM40
S-7040	46-8-31	105897R1	M.S. 2ND GEAR	5652,5752,A,C,5753,A,5756B,5852A,5756B,5852A,5853B,C
S-7042	46-8-37	236286R1	M.S. GEAR, 1ST & REV	5000
S-7043	46-8-39	871422R1	M.S. 4TH GEAR	5652A,5752,5752A
S-7044	46-8-41	968867R1	M.S. 2ND GEAR	5652A,B
S-7045	46-8-82	443607C1	M.S. 3RD GEAR	5052A,5652,5752
S-7046	46-8-84	443608C1	M.S. 4TH GEAR	5052A,5052C,5652,B
S-F261	46-8-87	487973C1	GEAR-MAINSHAFT	CM5052C
S-7047	46-8-89	444731C1	M.S. 4TH GEAR	5052B,5652A,5752
S-7048	46-8-93	443611C1	M.S. 3RD GEAR	5052D,5252A,5752C,5753A,5756B
S-7049	46-8-95	444730C1	M.S. 3RD GEAR	5052B,5652A
S-7050	46-8-96	478934C1	M.S. 4TH GEAR	5052D,5252A,5756B
S-7051	46-30-12-1X	454800C91	COUNTERSHAFT	5000
S-7053	46-196-17	112205R1	C.S. 3RD GEAR	5052D,5552D,5756,5852A,5853A,5252A,5752,5753
S-7054	46-196-29	171060R1	C.S. 3RD GEAR	5852B,5552B,5052B,5652A,B
S-7055	46-196-35	871423R1	C.S. 4TH GEAR	5552B,5052B,5652A,5752A
S-7056	46-196-37	968866R1	C.S. 2ND GEAR	5052B,C,5652A,B
S-7057	46-196-40	286922C1	C.S. 4TH GEAR	CM5052C,D,5552C,D,5252A,5852A,5756B

REPLACEMENT GEARS AND PARTS

APPLICATION: TTC TRANSMISSIONS

NEW STAR NUMBER	REPLACEMENT FOR		DESCRIPTION	APPLICATION MODEL
TTC NUMBER	INTERNATIONAL NUMBER			
S-7058	46-362-21	444732C1	MAINSHAFT	5000
S-4626	46-466-9	105075R1 105910R1	CLUTCH, 2ND & 3RD	5000,CM50
S-5731	47-1-1	478913C1	C.S. DRIVE GEAR	CM5052A,B,C,D,CM5552A,B,C,D
S-5732	47-1-3	478933C1	C.S. DRIVE GEAR	CM5852A,5252A
S-7059	47-8-1	478914C1	M.S. 1ST GEAR	CM50
S-7060	47-8-3	478915C1	M.S. 2ND GEAR	5052A,D,5252A
S-7061	47-8-5	478917C1	M.S. REVERSE GEAR	CM50
S-7062	47-8-6	483396C1	M.S. 2ND GEAR	5052B,C
S-5914	47-19-79-1X	1662954C91	RETAINER W/SEAL	CM55
S-5880	47-30-1	478907C1	COUNTERSHAFT	CM50
S-7063	47-362-1	478919C2	MAINSHAFT	CM50
S-7064	47-465-1	478906C1	COLLAR, 1ST & REV.	CM50,ES62-5
S-8264	49-1-1	1654834C1	C.S. DRIVE GEAR	CM49,ES52-5
S-8272	49-8-1	1654835C1	GEAR-MAINSHAFT	CM49
S-8269	49-8-3	1654837C1	M.S. 1ST GEAR	CM49,ES52-5
S-A124	49-8-5	1654840C1	M.S. 2ND GEAR	CM49
S-8276	49-8-7	1654842C1	M.S. 3RD GEAR	CM49,ES52-5
S-A277	49-8-9	1663748C91	M.S. 4TH GEAR	CM49
S-8130	49-8-11	1654845C1	M.S. 4TH GEAR	ES52-5D,4954D
S-F134	49-8-13	—	MAINSHAFT	ES43-5
S-13613	49-8-18	1699813C1	GEAR-MAINSHAFT	ES43-5A
S-16189	49-8-19	—	GEAR-MAINSHAFT	ES43-5D
S-13727	49-8-20	1699811C1	GEAR-MAINSHAFT	ES43-5A, 5D, ES53-5A
S-13837	49-8-21	1699810C1	GEAR-MAINSHAFT	ES43-5
S-8268	49-30-3	1654891C1	COUNTERSHAFT	CM49
S-8273	49-35-8-1X	1654893C1 1668156C1	INPUT SHAFT	CM49,ES52-5
S-F133	49-35-11-1X	1694633C91	INPUT SHAFT	ES43-5A,5D
S-E945	49-35-20-1X	—	INPUT SHAFT	ES43,53-5D,5E
S-11638	49-69-1-1X	2500293C91	FORK ASSEMBLY	ES43,53-5D
S-8278	49-196-3	1654841C1	C.S. 3RD GEAR	CM49,ES52-5
S-8266	49-196-7	1654844C1	C.S. 4TH GEAR	954D,ES52-5D
S-E636	49-464-1X	1699808C91	SYNCHRONIZER	ES43-5A,5D,ES53-5A,5D
S-8274	49-466-2	1654843C1	CLUTCH GEAR, 4TH & 5TH	CM49, ES42-5,ES52-5
S-A822	49-466-4	—	GEAR, CLUTCH	CM49,ES43-5D,ES53-5A,D
S-7065	50-80-1	—	3/8 CHROME BALL	CM50
S-5724	53-8-1	593894C1	M.S. GEAR, REVERSE	CM55
S-10286	53-8-5	2500693C1	GEAR-MAINSHAFT	CM55
S-5722	53-8-9	593896C1	M.S. 1ST GEAR	CM55
S-5723	53-8-10	593901C1	M.S. 2ND GEAR	CM5552A,D,CM5852D
S-5725	53-8-14	593903C1	M.S. 3RD GEAR	CM5552D,5852A
S-5726	53-8-16	593904C1	M.S. 3RD GEAR	CM5552A
S-5728	53-8-21	593907C1	M.S. 4TH GEAR	CM5552D,CM5852A
S-8464	53-8-22	593908C1	M.S. 4TH GEAR	5552A,C
S-8280	53-8-26	1651249C1	M.S. GEAR, 3RD	5552D,5852A
S-7066	53-35-1-1X	1662962C91	INPUT SHAFT	5052
S-5932	53-35-2-1X	576641C92	INPUT SHAFT	5052A
S-5931	53-35-3-1X	576643C92	INPUT SHAFT	5052A,D
S-8456	53-35-9-1X	1662970C91	INPUT SHAFT	5552A,B
S-7067	53-35-13-1X	576642C92	INPUT SHAFT	CM5852A
S-7068	53-35-14-1X	576644C92	INPUT SHAFT	CM5852A
S-8457	53-35-15-1X	1662965C91	INPUT SHAFT	5852A
S-7069	53-35-19-1X	1662967C91	INPUT SHAFT	CM5852
S-8458	53-35-20-1X	1662968C91	INPUT SHAFT	5852A
S-8817	53-66-3-1X	593925C91	FORK W/PADS, 2ND & 3RD	CM55,CM59,ES60-5

LATEST ADDITIONS TO OUR CATALOG

EXCEPT WHERE SPECIFIED, ALL PARTS SUPPLIED ARE S&S/NEWSTAR. USE OF OTHER MANUFACTURERS' NAMES, PART NUMBERS, OR TRADEMARKS ARE FOR INFORMATIONAL AND IDENTIFICATION PURPOSES ONLY.



REPLACEMENT GEARS AND PARTS

APPLICATION: TTC TRANSMISSIONS

TRANSMISSION

REPLACEMENT FOR				
NEW STAR NUMBER	TTC NUMBER	INTERNATIONAL NUMBER	DESCRIPTION	APPLICATION MODEL
S-7070	53-362-3	593909C91	MAINSHAFT	CM55,ES62-5
S-5730	53-466-1	593897C1	M.S. CLUTCH GEAR, 2ND & 3RD	CM5552,5852
S-15668	56-381-3	—	SNAP RING	CM55, 5000
S-15178	56-482-1	—	BEARING	ES52-5, 53-5
S-8920	59-66-1-1X	1653096C91	FORK 1ST AND REVERSE	CM55,CM59,ES60-5
S-4746	60-463-10-1X	424469C1	OIL SEAL W/SLEEVES	ES60,62,65,67,70-5A,5D, ES052,60-7A, CM50,55,60 6000
S-8131	62-8-36	100067R1	GEAR, 1ST & REV.	6452,A.6453,5852G,6052C
S-8132	62-8-43	495201C1	M.S. 3RD GEAR	
S-7714	62-30-17	279040C1	SEE 311450X	
S-15664	62-381-7	—	SNAP RING	CM60, 6000
S-7071	62-466-14	100069R1	M.S. CLUTCH, 2ND & 3RD	CM6052
S-8233	63-8-1	495197C1	M.S. 1ST GEAR	CM60,ES65-5,ES70-5
S-8235	63-8-4	495198C1	M.S. 2ND GEAR	6052A,6252A,6052D
S-8459	63-35-34-1X	576645C91	INPUT SHAFT	6052,ES65A,B,D,E,
S-8460	63-35-37-1X	1662990C91	INPUT SHAFT	6052,ES65-5
S-8461	63-35-39-1X	1662991C91	INPUT SHAFT	6052C,ES65E
S-8462	63-35-46-1X	576647C91	INPUT SHAFT	6052C, ES65-5E
S-8463	63-35-57-1X	576651C91	INPUT SHAFT	6052A,B,D,ES65-5A,5B
S-7114	67-47-1	1695580C1	WASHER, 3RD & 4TH	5000,CM50
		443610C1		
S-5554	70-8-33	177430R1	M.S. 1ST GEAR	R8341C,D,E
S-5549	70-8-49	390726C1	M.S. 4TH GEAR	R8341D,G,K
S-5567	70-196-29	390725C1	C.S. 2ND GEAR	R8341
S-5551	70-465-6	177444R1	COLLAR, 1ST & 2ND	R8341
S-5560	70-465-8	876595R1	COLLAR, 3RD & 4TH	R8341
S-5552	70-466-5	177445R1	CLUTCH GEAR	R8341
S-7080	82-196-35	—	C.S. 4TH GEAR	8251
S-E015	82-362-10	268220C1	MAINSHAFT	8000 SERIES
S-C323	97-1-21	486865C1	GEAR-COUNTERSHAFT	PS0150-16A,1214-3A,1414-3A
S-C324	97-8-34	432250C1	M.S. DRIVE GEAR	1010-2A
S-C325	97-8-161	593672C1	AUX. M.S. DRIVE GEAR	1414/42 TEETH
S-10290	97-8-248	—	GEAR-MAINSHAFT	1414-2A,3A,PS0150-16,1750-18A
S-10287	97-8-249	—	GEAR-MAINSHAFT	1414-2A,3A,PS0150-16,1750-18A
S-C326	97-35-6	432249C1	INPUT SHAFT	1010-4A,1214-4A
S-C327	97-35-9	432237C1	INPUT SHAFT	1214-3A,4A,1420-3A,1010-2A
S-5943	97-35-30	507631C1	INPUT SHAFT	1107-2A,1372A,B
S-7438	97-35-34	—	INPUT SHAFT	1310,1412,1414,1420
S-C328	97-66-86	—	SPLITTER FORK	1310,1410,1412
S-C329	97-66-87	—	FORK	1420
S-7084	97-196-21	399636C1	C.S. 4TH GEAR	1062C,1263B,1007-2B,2D,3A,1272A
S-7086	97-196-67	448804C2	C.S. GEAR, OVERDRIVE	1453A
S-7087	97-196-75	399637C2	C.S. 5TH GEAR	1062A,1262A,1362A, 1007-2A,2C,1207-2A
S-7089	97-196-83	485330C1	C.S. 4TH GEAR	1062A,1262A,1362A,1007-2A,1207-2A
S-C330	97-362-51	593675C1	MAINSHAFT	PS0150-16A,16B,1414-3A, 1420-3B,1412-3A
S-15667	97-381-34	—	SNAP RING	MULTIPLE AUX TRANS APPLICATIONS
S-D978	97-463-32	401218C92	OIL SEAL	SST SERIES, VITON LIP
S-D979	97-463-33	401219C92	OIL SEAL	SST SERIES, VITON LIP
S-5544	97-465-4	399611C1	COLLAR, 4TH	1352,1452,1453,1007,1272A,1207
S-7092	97-465-5	432252C1	COLLAR, SPLITTER	SEE SGR 97-465-26
		593677C1		
S-7093	97-465-7	435985C1	AUX. M.S. COLLAR	1214-3A,4A,1420-3A,1007-2A,3A,3B
S-7094	97-465-21	73168C1	COLLAR, 2ND & 3RD	1352A,1272,1007,1207,1107-2A, 1372,1010,1310,1410

LATEST ADDITIONS TO OUR CATALOG

EXCEPT WHERE SPECIFIED, ALL PARTS SUPPLIED ARE S&S/NEWSTAR. USE OF OTHER MANUFACTURERS' NAMES, PART NUMBERS, OR TRADEMARKS ARE FOR INFORMATIONAL AND IDENTIFICATION PURPOSES ONLY.

REPLACEMENT GEARS AND PARTS

APPLICATION: TTC TRANSMISSIONS

NEW STAR NUMBER	REPLACEMENT FOR		DESCRIPTION	APPLICATION MODEL
TTC NUMBER	INTERNATIONAL NUMBER			
S-5545	97-465-23	399610C3	COLLAR, 4TH	1007,1272A,1207
S-7092	97-465-26	432252C1	COLLAR, SPLITTER	1010,1214,1020,1420
		593677C1		
S-7095	97-465-27	591083C1	COLLAR, LOW GEAR	1412,1414,1207,1420
S-5944	97-465-33	507612C1	COLLAR	1107-2A,1372-A,B
S-5558	97-465-50	486858C1	COLLAR	1010-3A,5A
S-C331	97-466-13	593682C1	CLUTCH-MAINSHAFT	1214-3A,4A,1420-3A,1007-2A,2B,3A
S-F242	97-509-10-1X	—	FORK ASSEMBLY	
S-8219	98-1-1	456417C1	C.S. 3RD GEAR	P,1241C,D
S-5564	98-8-3	456413C1	M.S. 2ND GEAR	1241
S-5562	98-8-13	456531C1	M.S. GEAR OVERDRIVE	1241
S-7099	98-30-9-1X	456405C21	COUNTERSHAFT	1241C,P1241C
S-5565	98-35-1	456411C1	INPUT SHAFT	1241
S-8217	98-196-7	456532C1	C.S. 2ND GEAR	1241,P
S-8218	98-196-8	456533C1	GEAR, OVERDRIVE	1241,P
S-5559	98-362-3	491693C1	MAINSHAFT	1241C,D
S-13098	98-381-2	—	SNAP RING	1241
S-7102	98-465-4	456404C1	COLLAR	1241
S-F262	101-1-4	1681387C1	GEAR-AUX COUNTERSHAFT	ES065-7A
S-A959	101-8-8	—	GEAR-MAINSHAFT	ES52-7
S-15319	101-8-18	1677685C1	GEAR-MAINSHAFT	ES52-7A, ES065-7A
S-E741	101-8-20	1677686C1	GEAR-MAINSHAFT	ES52-7A
S-A960	101-8-21	1691637C1	GEAR-MAINSHAFT	ES066-7B
S-E877	101-8-22	—	GEAR-MAINSHAFT	ES066-B,ES065-7
S-11517	101-8-23	—	GEAR-MAINSHAFT	ES52-7B,ES066-7B
S-E948	101-8-24	—	GEAR-MAINSHAFT	ES066
S-E944	101-8-25	—	GEAR-MAINSHAFT	ES066
S-E742	101-8-28	—	GEAR-MAINSHAFT	ES52-7A
S-11996	101-19-2-1X	1681344C91	RETAINER W/CAPS	ES52-7,60-5,65-5 & ES065-7
S-A961	101-35-4	1681399C91	INPUT SHAFT	ES066-7B
S-C703	101-35-16-1X	1694689C91	INPUT SHAFT	ES065-7A-7 SPEED
S-13839	101-35-19-1X	—	INPUT SHAFT	ES52-7B - 1.750" - 10 SPLINE
S-14087	101-35-24-1X	—	INPUT SHAFT	ES52-7A, 7B, ES065-7A, ES066-7B
S-E947	101-35-26-1X	—	INPUT SHAFT	ES066
S-13663	101-37-1	1681328C1	SLEEVE	ES52-7A, ES065-7A
S-11639	101-69-1-1X	2502052C91	FORK ASSEMBLY	ES52-7A,B
S-11640	101-69-2-1X	2500296C91	FORK ASSEMBLY	ES52-7A,B
S-11641	101-69-3-1X	2500297C91	FORK ASSEMBLY	ES52-7A,ES065-7A
S-E642	101-196-6	1677690C1	GEAR-COUNTERSHAFT	ES52-7A,ES065-A
S-10224	101-196-8	—	GEAR-MAINSHAFT	ES52-7B, ES066-7B
S-F080	101-196-9	—	GEAR-COUNTERSHAFT	ES066-B
S-F193	101-362-5-1X	1681303C1	MAINSHAFT	ES52-7A
S-A962	101-362-6	1681304C92	MAINSHAFT	ES52-7B,ES066-7B
S-14229	101-362-10-1X	—	MAINSHAFT	ES066-7
S-15357	101-362-10-2X	—	MAINSHAFT KIT	ES066-7, ES56-5, 7
S-E634	101-464-1X	1699809C91	SYNCHRONIZER, 6TH & 7TH	ES52-7A,7D,ES065-7
S-E635	101-464-2X	2500245C91	SYNCHRONIZER, 4TH & 5TH	ES52-7A,7B,ES065-7A,7B
S-10500	101-465-7	1677673C1	CLUTCH COLLAR	ES43,53-5A,5D,ES52-7A,ES065-7A
S-A865	101-466-2	1677681C1	GEAR-MAINSHAFT	MATES W/313775X-ES43-5A, 5D,ES53-5A,5D
S-15185	101-482-1	—	BEARING	ES56-7B
S-C082	101-486-1-1X	1681335C91	CLIP KIT	ES52-7A,7B,ES065-7A,066-7B
S-E970	101-486-4-1X	1681395C1	OIL TROUGH KIT	ES065-7A
S-13523	104-8-7	—	GEAR-MAINSHAFT	ES52-7B, 56-7B, 066-7B
S-F081	201-8-2	1668533C1	GEAR-MAINSHAFT	PSO125-9A,140-9A,150-9A, 9-VPD,LPS125-9A, 140-9A

LATEST ADDITIONS TO OUR CATALOG

EXCEPT WHERE SPECIFIED, ALL PARTS SUPPLIED ARE S&S/NEWSTAR. USE OF OTHER MANUFACTURERS' NAMES, PART NUMBERS, OR TRADEMARKS ARE FOR INFORMATIONAL AND IDENTIFICATION PURPOSES ONLY.



REPLACEMENT GEARS AND PARTS

APPLICATION: TTC TRANSMISSIONS

TRANSMISSION

NEW STAR NUMBER	REPLACEMENT FOR		DESCRIPTION	APPLICATION MODEL
TTC NUMBER	INTERNATIONAL NUMBER			
S-A963 S-13960	201-8-4 201-8-35	1668534C1 1668535C1	GEAR-MAINSHAFT GEAR-MAINSHAFT	PSO140-9A,10A,PSO125 PSO, PS125, 140, PSO, PS9VPD, LPS125-9A, 140-9A
S-A964 S-13522 S-12026 S-13813 S-11518	201-8-37 201-8-41 201-8-43 201-8-44 201-8-45	1668536C1 1668507C1 1685527C1 — 1693038C1	GEAR-MAINSHAFT GEAR-MAINSHAFT GEAR-MAINSHAFT GEAR-MAINSHAFT GEAR-MAINSHAFT	PSO140-9A,10A,PSO125 PRO-SHIFT PSO140-10S PSO140,PS1PSO9VPD,LP140-9A PRO SHIFT 10 SPEEDS - PS140-10S PSO100,125,140,160,PSX150, ASO125,140,150,165
S-F246	201-8-46	1693040C1	GEAR-MAINSHAFT	PSO100-10S,125,140,150-10S, 160-10S,100-VPD
S-C094 S-C095 S-A965 S-C096 S-C097 S-C098 S-C541 S-14104 S-16577 S-C093 S-A966 S-D448	201-8-48 201-8-49 201-35-2 201-196-2 201-196-40 201-196-41 201-362-1-1X 201-362-3 201-463-8 201-465-2 201-465-4 201-465-5	1693036C1 1693035C1 1668557C1 1668526C1 1693034C1 — 1669351C91 — 1668500C1 1668524C1 1669422C1 1677092C1	GEAR-MAINSHAFT OD GEAR-MAINSHAFT OD INPUT SHAFT GEAR-C.S. OD GEAR-COUNTERSHAFT GEAR-COUNTERSHAFT MAINSHAFT MAINSHAFT OIL SEAL CLUTCH COLLAR COLLAR,SYNCHRO SYNCHRO HUB	ASO,PSO SERIES 10 SPEEDS, 40 TEETH ASO,PSO SERIES 10 SPEEDS, 50 TEETH PSO140-9A,10A,PSO125 ASO,PSO SERIES 10 SPEEDS, 46 TEETH PSO,ASO SERIES PSO125,140-10S/ASO165-10S PS SERIES-9 AND 10 SPEEDS PSO140 PRO SHIFT - 10 SPEEDS PSO140, 150-9A, PS95, 125-9A PSO SERIES PSO140-9A,10A,PSO125 ASO, PSO100-10S,VPD, PSO125,140,150,160-10S
S-F260 S-F155 S-E982 S-7103 S-7104 S-7439 S-4627 S-4153 S-7714 S-7109 S-5915 S-8379 S-3242 S-8818 S-5916	201-466-2 201-486-1 201-563-1-1X 1016-W 7735X 7736X 8072X 310227X 311450X 311623X 312475-16X 312475-25X 312475-28X 312475-29X 312475-40X	1668505C1 1677199C1 1668502C91 106312R1 182156R91 205723R91 105924R91 100071R1 279040C11 254591C11 400223C91 1662893C91 478994C92 496112C91 1648173C91 1662894C91	COLLAR SHOE STOP SYNCHRONIZER ASSY SPACER, 4TH OR 5TH SYNCHRONIZER, 2ND OR 3RD SYNCHRONIZER, 4TH & 5TH SYNCHRONIZER, 2ND & 3RD SYNCHRONIZER, 2ND & 3RD COUNTERSHAFT INPUT SHAFT GASKET SET GASKET SET GASKET SET GASKET SET GASKET SET	ASO, PSO SERIES FOR SHIFT FORK 10 SPEEDS-PSO140-10S 5000,CM50,ES62-5 3000 3000 5000,CM50 6000,CM60 6000 R8341 1010-2A,1062,1252,1253,1263 1241 CM50,55,ES62-5 ES70-5,CM60 CM49,ES42-5,ES52-5
S-15665 S-B237 S-B236 S-9616 S-13493 S-4649 S-4154 S-F434 S-15666 S-C453	312475-45X 312475-46X 312475-47X 312476-17X 312589X 312764X 312766X 313024-9X 313024-20X 313042	1677255C91 1681352C91 1693373C91 — 205735R21 235558R92 100080R92 1662907C91 1692725C91 449131C91	GASKET SET GASKET SET GASKET SET BEARING & SEAL KIT COUNTERSHAFT SYNCHRONIZER, 4TH & 5TH SYNCHRONIZER, 4TH & 5TH SNAP RING KIT SNAP RING KIT AIR REGULATOR	PS125, 140, 150-9A ES52-7A,ES065-7A ES43-5A,5D,ES53-52,5D P,1241,MANUAL,AIR-MATIC MODEL 3152 5000,CM50 6000,CM60,ES52-5 SST10 TRANSMISSIONS SST SERIES PSO100-10S,125,140,150-DS, 160-10S,100VPD,ETC
S-E658 S-7112 S-11974 S-9597 S-13749	313240-3X 313401-13X 313401-20X 313432-10X 313432-33X	593913C91 1662922C91 — 1651500C93 —	SHIM KIT THRUST WASHER KIT WASHER KIT BEARING & SEAL KIT BEARING & SEAL KIT	CM50,60,ES60-5,ES65-5 CM50,ES52-5 1310,1412,1414,1420 CM 50,55 ASO, PSO, LPS150 SERIES

LATEST ADDITIONS TO OUR CATALOG

EXCEPT WHERE SPECIFIED, ALL PARTS SUPPLIED ARE S&S/NEWSTAR. USE OF OTHER MANUFACTURERS' NAMES, PART NUMBERS, OR TRADEMARKS ARE FOR INFORMATIONAL AND IDENTIFICATION PURPOSES ONLY.

REPLACEMENT GEARS AND PARTS

APPLICATION: TTC TRANSMISSIONS

NEW STAR NUMBER	REPLACEMENT FOR		DESCRIPTION	APPLICATION MODEL
	TTC NUMBER	INTERNATIONAL NUMBER		
S-5508	313453X	593892C91	SYNCHRONIZER, 4TH & 5TH	CM55
S-5509	313459X	593891C91	SYNCHRONIZER, 2ND & 3RD	CM55
S-10288	313535X	1653039C91	SYNCHRONIZER, 4TH & 5TH	ES60-5
S-5933	313536X	1649726C91	SYNCHRONIZER, 2ND & 3RD	CM55
S-7113	313558X	1654833C1	SYNCHRONIZER, 4TH & 5TH	CM40, ES42-5, ES52-5
S-C454	313630X	1669363C91	SLAVE VALVE	PS0100-10S,125,140,150-DS, 160-10S,100VPD,ETC
S-E824	313669X	1691973C91	O-RING KIT	PS,PSO ANF LPS SERIES
S-10314	313680-1X	1681307C91	FORK ASSEMBLY	ES52-7A
S-10315	313681-1X	1681306C91	FORK ASSEMBLY	ES52-7A
S-10316	313683-1X	1681308C91	FORK ASSEMBLY	ES52-7A
S-10037	313723-1X	1691692C91	FORK ASSEMBLY	ES53-5A
S-12004	313760-1X	1693044C91	FORK ASSEMBLY	ES43-5A,5D,ES53-5A,5D
S-12005	313760-2X	1693054C91	FORK AND RAIL KIT	ES43-5A,5D,ES53-5A,5D
S-F494	313761-1X	1693045C91	FORK ASSEMBLY	ES43-5D,53-5D,CM4954A,D, ES52-5A,5D
S-A423	313764X	1693051C91	SYNCHRONIZER, 2ND & 3RD	ES43-5A,5D,ES53-5A,5D
S-A422	313775X	1693052C91	SYNCHRONIZER, 4TH & 5TH	ES43-5A,5D,ES53-5A,5D
S-A421	313776X	1677672C92	SYNCHRONIZER, 2ND & 3RD	ES42-5A,5D,ES53-5A,5D
S-C092	330810	456425C1	WASHER	PS0150-16A,16B,PS110-7A,7B, PS140-7A,PS145-7A,ETC
S-7114	330818	1695580C1 443610C1	WASHER, 3RD & 4TH	5000,CM50
S-7115	330866	478922C1	SPACER, 1ST SPD	CM50, ES62-5
S-7116	330867	478932C1	WASHER, REVERSE	CM50, ES62-5
S-6246	500729	—	NUT, MAINSHAFT	5000,CM50
S-7117	500898	365464C1	NUT, MAINSHAFT	6000,CM60
S-C106	501200	591219C1	NUT, MAINSHAFT	ES42,43,52,53,60,62-5D, CM40,49,50,55
S-7118	545065	591066C1	MAINSHAFT NUT	1207,1252,1253,1310,1352,1362, 1372,1412,1414,1420
S-C100	550988	1654852C91	BEARING	ES42,52,43,53-5A,5D/CM49
S-C101	550989	1654853C91	BEARING	ES42,52,43,53-5A,5D, ES52-7A,ES065-7A
S-C102	550991	1654854C91	BEARING	ES42,43,52,53-5A,5D, ES52-7A,ES065-7A
S-7440	105C-137	697924R6	CLUTCH RELEASE FORK	14 AND 15 1/2 2-PLATE
S-9110	106C-939	—	10 SHAFT	LONG SHAFT 10 SPLINED
S-5910	106C-1047	—	9 1/2 SHAFT	5000,CM40,49,50,55
S-5911	106C-1094	301519R1	8 1/2 SHAFT	5000,CM40,49,50,55
S-4221	106C-1185	229998R1	5 3/4 SHAFT	CM50,60
S-3347	106C-1498	1662768C1	6 1/2 SHAFT	5000
S-5761	128C-20	268339C1	BUSHING	CM40,50,60,SST
S-7660	274C-6	697956R1	DRIVE PIN	CM50,60- 14 AND 15 1/2 2-PLATE
S-9616	T158	—	BEARING & SEAL KIT	P,1241, MANUAL AIR-MATIC
S-9597	T180	1651500C93	BEARING & SEAL KIT	CM50,55
S-9611	T210	—	BEARING & SEAL KIT	CM4054D
S-B842	T221	1693487C91	BEARING & SEAL KIT	ES52-5A,5D

REPLACEMENT GEARS AND PARTS

APPLICATION: TTC TRANSMISSIONS
MADE IN U.S.A.

TRANSMISSION



NEW★STAR NUMBER	REPLACEMENT FOR PART NUMBER	DESCRIPTION	APPLICATION - MODEL
S-E634	101-464-1X	BACK TAPERED 6TH & 7TH SPEEDS	ES52, ES065-7
S-E635	101-464-2X	BACK TAPERED 4TH & 5TH SPEEDS	ES52, ES065-7
S-A422	313775X	NON-BACK TAPER 4TH & 5TH SPEEDS	ES43, 53-5
S-A423	313764X	NON-BACK TAPER 2ND & 3RD SPEEDS	ES43, 53-5
S-A421	313776X	NON-BACK TAPER 2ND & 3RD SPEEDS	ES42, 53-5
S-E636	49-464-1X	NON-BACK TAPER 2ND & 3RD SPEEDS	ES43, 53-5



LATEST ADDITIONS TO OUR CATALOG

EXCEPT WHERE SPECIFIED, ALL PARTS SUPPLIED ARE S&S/NEWSTAR. USE OF OTHER MANUFACTURERS' NAMES, PART NUMBERS, OR TRADEMARKS ARE FOR INFORMATIONAL AND IDENTIFICATION PURPOSES ONLY.

REPLACEMENT BEARING, SEAL & GASKETS KITS

APPLICATION: MULTIPLE APPLICATIONS



NEW STAR NUMBER	REPLACEMENT FOR INDUSTRY	REFERENCE	DESCRIPTION
S-9219	T-5MK	—	WARNER T5 NON WORLD CLASS-MASTER KIT W/ SMALL PARTS KIT
S-9842	T23	—	CLARK 250,265
S-9747	T27	—	NEW PROCESS 540,541,542 EARLY
S-9605	T29	—	NEW PROCESS 541,542
S-9606	T29B	—	NEW PROCESS 542 FORD LATE MODELS
S-9806	T82	—	WARNER T98
S-9609	T82D	—	WARNER T18,19 NAVISTAR
S-7216	T127	326326C91	NEW PROCESS 435 FORD
S-8819	T127B	—	NEW PROCESS 435 GM
S-9614	T145A	K-1850	FULLER 610,6610
S-9599	T146	K-1851	FULLER RT,RT0613,6613
S-7197	T148	K-2127	CLARK 280,282,285
S-9601	T149	K-1862	FULLER 12513
S-9613	T149AUX	—	FULLER AUX. RT,RT0,12513
S-7214	T156	281817C91	INTERNATIONAL T34,35,36,495,496
S-7195	T157	8885008	GM SM 465
S-9616	T158	312476-17X	DANA® P,1241,MANUAL,AIR-MATIC
S-9597	T180	313432-10X	DANA® CM 50,55
S-B905	T185	—	TR107,TRL1076,1078
S-9603	T187	208-SH-84	MACK TRXL 107,1071
S-7213	T190	K-2128	CLARK 280,282,285 VHD
S-9600	T203	K-1880, K-1973	FULLER 11608,609,613,615,12609,12610
S-9602	T205	K-1870, K-1971	FULLER 14608,609,610
S-9598	T206	K-1871, K-1972	FULLER 14613
S-9608	T207	K-1872, K-1979	FULLER 14608,615
S-9604	T208	K-2120	CLARK 450,FS 4005A,B W/ 1 1/16" OR 1 1/2" INPUT SHAFT
S-9834	T208D	K-2129	CLARK FS4005,4205 W/ 1 3/4" INPUT SHAFT
S-9611	T210	—	DANA® CM 4054D
S-9615	T211	—	FULLER
S-13213	T214	208-SH101-A	T2060,2070,2080,2090,2100,2130,2180
S-B842	T221	313432-46X	DANA® ES52-5A,5D
S-9820	T235	—	NEW VENTURE 3500-GETRAG-CHEVY '88-89' -1ST DESIGN
S-9822	T235B	—	NEW VENTURE 3500-GETRAG-CHEVY '91 & UP-3RD DESIGN
S-9824	T261R	—	DODGE GETRAG G360 '89-91'
S-9201	T300ZFX	—	ZF S5-42 FORD- COMPLETE W/ M.S. BRGS.
S-A871	T300ZF-1	—	ZF S5-42 FORD- W/O CAGED NEEDLE BRGS.
S-9826	T308R	—	NEW VENTURE 4500 CHEVY & DODGE W/ CAGED NEEDLE BRGS.
S-7204	T390	K-2124	CLARK 390,397,CL550,FORD
S-9884	T535	—	CHRYSLER A535
S-9596	T1000	K-1856, K-2780	FULLER 906,909,910,913,915,955,958,9508,9509,9513
S-9451	T1288F	—	MAZDA M5R2- FORD 1988-93 BRONCO,E+F150/350
S-9827	T1356R	—	WARNER I356 TRANSFER CASE
S-9450	T1488F	—	MAZDA M5R1- FORD 1988-93 AEROSTAR,BRONCO II,EXPLORER,RANGER 2.9/3.0

LATEST ADDITIONS TO OUR CATALOG

EXCEPT WHERE SPECIFIED, ALL PARTS SUPPLIED ARE S&S/NEWSTAR. USE OF OTHER MANUFACTURERS' NAMES, PART NUMBERS, OR TRADEMARKS ARE FOR INFORMATIONAL AND IDENTIFICATION PURPOSES ONLY.



REPLACEMENT BEARING, SEAL & GASKETS KITS

APPLICATION: MULTIPLE APPLICATIONS

TRANSMISSION

NEW★STAR NUMBER	REPLACEMENT FOR INDUSTRY	REPLACEMENT FOR REFERENCE	DESCRIPTION
S-A781	T2041	K-2041	MID RANGE FS 5106, 6206
S-9053	T2043	K-2043	FULLER 15715
S-D948	T2277	K-2277	FULLER 14710, 15710, 16710
S-D750	T2284	K-2284	FULLER 11715
S-11446	T2286	K-2286	FULLER RTLO14713A
S-11447	T2287	K-2287	FULLER RTLO16713A
S-F489	T2773	K-2773	FULER RTLO14610B,15610B,16610B,17610B,18610B
S-11448	T2865	K-2865	FULLER RTLO18718B
S-11449	T2924	K-2924	FULLER 9210 THRU 18210
S-15477	T3132	K-3132	FULLER FRO SERIES - 10 SPEEDS
S-12099	T3286	K-3286	FULLER 18913-T2
S-13017	T3340	K-3340	FULLER 16918, 18918, 20918
S-16576	T3342	K-3342	FULLER RTO16913A
S-11450	T3343	K-3343	FULLER 16913A
S-15365	T3346	K-3346	FULLER RTLO16713A
S-9823	T4500BK	—	NEW VENTURE 4500 GM & DODGE
S-E593	T7032	K-7032	MID RANGE FS6306
S-14103	T7052	K-7052	FULLER FS5306A, 6306A
S-6672	—	10332	INTERNATIONAL TRUCK 4590-IHC



CHECK OUT OUR NEW
SUITCASE KITS FOR HEAVY DUTY FULLER APPLICATIONS
SUCH AS K2336, K2468 AND K3600

NEW CLUTCH ASSEMBLIES

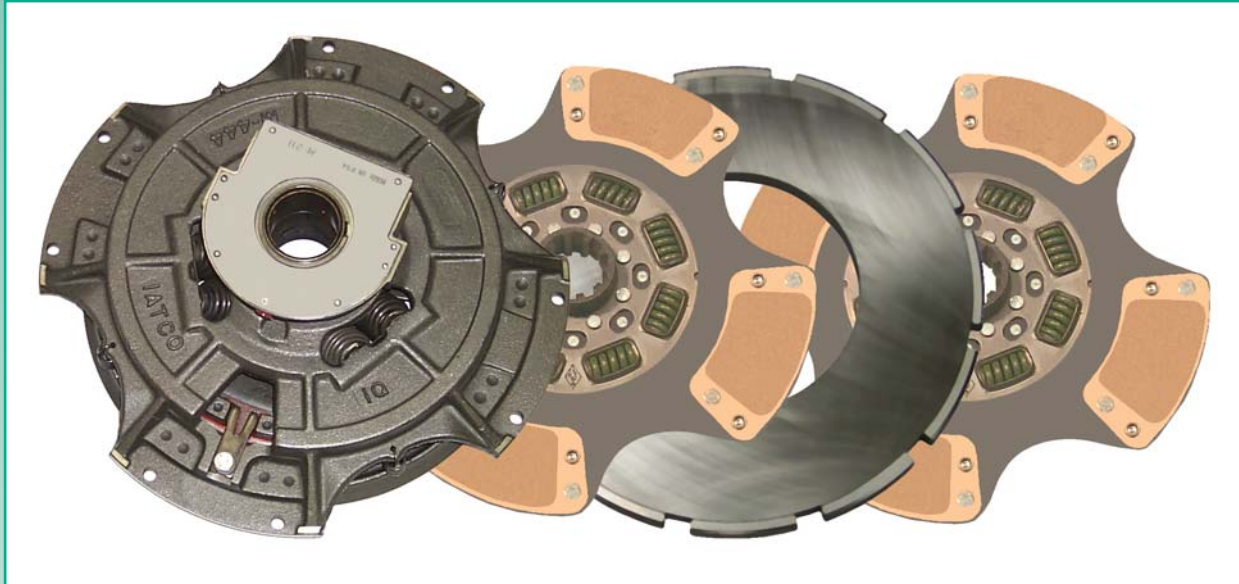

THE MOST COMPLETE LINE OF NEW CLUTCHES FOR CLASS 6, 7, AND 8 TRUCKS AVAILABLE IN THE AFTERMARKET.

MATCHED UNIT CONFIGURATIONS TO FIT YOUR NEEDS UP TO THE HIGHEST TORQUE RATED ENGINES. ALL MAKES COVERAGE FOR NORTH AMERICAN PRODUCED CLASS 6-7-8 VEHICLES.

1 YEAR, 100,000 MILE WARRANTY.

MADE IN THE U.S.A.

NEW CLUTCH ASSEMBLIES

NEW STAR NUMBER	REPLACEMENT FOR DANA® NUMBER	COVER ASSEMBLY NUMBER	ADJUSTMENT TYPE	BEARING TYPE	PLATE LOAD POUNDS	TORQUE RATING (ft./lbs)	CARRIER STYLE	FRICITION MATERIAL	CERAMIC CONFIG	NM OF SPRINGS	CONVENTIONAL	FREE TRAVEL	MIN. FLYWHEEL OPENING
14" X 1 3/4" CAST IRON TWO PLATE													
S-8307	107035-36	127400-1	MANUAL	GREASABLE	3200	600	ROUND	ORGANIC		R			7"
S-8308	107035-22	127400-1	MANUAL	GREASABLE	3200	800	ROUND	CERAMIC		R			7"
S-8309	107035-54	127400-1	MANUAL	GREASABLE	3200	900	ROUND	ORGANIC		8	X		7"
S-8310	107035-53	127400-1	MANUAL	GREASABLE	3200	1000	ROUND	CERAMIC	VTL	8	X		7"
S-E351	107035-82	127400-4	MANUAL	GREASABLE	3600	1100	ROUND	ORGANIC		8	X		7"
S-E352	107063-59	127400-1	MANUAL	GREASABLE	3200	1150	4-PADDLE	CERAMIC	VSR	8	X		7"
14" X 2" CAST IRON TWO PLATE													
S-8303	107034-30	127390-1	MANUAL	GREASABLE	3200	600	ROUND	ORGANIC		R			7"
S-8304	107034-19	127390-1	MANUAL	GREASABLE	3200	800	ROUND	CERAMIC	VTL	R			7"
S-8305	107034-32 107034-54B	127390-1	MANUAL	GREASABLE	3200	1000	ROUND	ORGANIC		8	X		7"
S-8306	107034-53	127390-1	MANUAL	GREASABLE	3200	1000	ROUND	CERAMIC	VTL	8	X		7"
S-E353	107050-59	127390-1	MANUAL	GREASABLE	3200	1400	4-PADDLE	CERAMIC	VSR	8		X	7"
S-E354	107950-59	127390-4-M	MANUAL	GREASABLE	3200	1400	4-PADDLE	CERAMIC	VSR	8		X	7"
S-E601	107034-61	127390-1	MANUAL	GREASABLE	3200	1000	3-PADDLE	CERAMIC	VSR	8	X		7"
15 1/2" X 1 3/4" CAST IRON TWO PLATE													
S-8311	107090-22	127476-1	MANUAL	GREASABLE	3200	1000	ROUND	ORGANIC		R			7"
S-8313	107090-56	127476-1	MANUAL	GREASABLE	3200	1100	ROUND	ORGANIC		8	X		7"
S-8314	107090-52	127476-1	MANUAL	GREASABLE	3200	1250	ROUND	CERAMIC	VTL	8	X		7"
15 1/2" X 2" CAST IRON TWO PLATE													
S-8315	107091-27	127597-1	MANUAL	GREASABLE	3200	1000	ROUND	ORGANIC		R			7"
S-8316	107091-3	127597-1	MANUAL	GREASABLE	3200	1100	ROUND	CERAMIC	VTL	R			7"
S-8317	107091-77	127597-4	MANUAL	GREASABLE	3600	1250	ROUND	ORGANIC		8		X	7"
S-8318	107091-52	127597-1	MANUAL	GREASABLE	3600	1150	ROUND	CERAMIC	VTL	8	X		7"
S-E355	107091-77	127597-4	MANUAL	GREASABLE	3600	1250	ROUND	ORGANIC		8		X	7"
S-E416	107391-93	127597-6	MANUAL	GREASABLE	4000	1850	6-PADDLE	CERAMIC	VSR	10	X		8.5"
S-E417	107925-82	150698-4	MANUAL	GREASABLE	3600	1700	4-PADDLE	CERAMIC	VSR	7		X	10"
S-E419	107935-51	150698-4-M	MANUAL	GREASABLE	3600	1650	4-PADDLE	CERAMIC	VSR	9	X		10"
S-E420	107935-82	150699-4-M	EASE-A-JUST	GREASABLE	3600	1700	4-PADDLE	CERAMIC	VSR	7		X	10"
S-E421	107935-51	150699-4-M	EASE-A-JUST	GREASABLE	3600	1650	4-PADDLE	CERAMIC	VSR	9	X		10"
S-E603	107091-81	---	MANUAL	GREASABLE	3600	1400	4-PADDLE	CERAMIC	VSR	8		X	7"
S-E606	107391-74	---	EASE-A-JUST	GREASABLE	3600	1650	4-PADDLE	CERAMIC	VSR	10	X		8.5"
330MM X 1 1/4" & 1 3/8" & 1 1/2"													
S-8847	107605-1	330-1928	EXTERNAL	GREASABLE	2800	400	4-PADDLE	CERAMIC	VTL	8	X		7"
S-8853	107606-1	330-1928	EXTERNAL	GREASABLE	2800	400	4-PADDLE	CERAMIC	VTL	8	X		7"
S-8868	107611-2	330-1938	EXTERNAL	GREASABLE	2400	400	ROUND	ORGANIC		8	X		7"
S-8869	107943-3	330-1938	EXTERNAL	GREASABLE	2400	400	4-PADDLE	CERAMIC	VTL	8	X		7"
S-E423	LP1937-134 MU1266	330-1937	EXTERNAL	GREASABLE	2400	400	ROUND	ORGANIC		8	X		7"

CLUTCH



NEW CLUTCH ASSEMBLIES

NEW STAR NUMBER	REPLACEMENT FOR — DANA® COVER NUMBER ASSEMBLY NUMBER		ADJUSTMENT TYPE	BEARING TYPE	PLATE LOAD POUNDS	TORQUE RATING (ft/lbs)	CARRIER STYLE	FRICITION MATERIAL	CERAMIC CONFIG	NM OF SPRINGS	CONVENTIONAL	FREE TRAVEL	MIN. FLYWHEEL OPENING
14" DLB X 1 1/2" & 1 3/4"													
S-E425	LP1047-134	14-1047	EXTERNAL	GREASABLE	3200	500	ROUND	ORGANIC		10	X		7"
S-E426	LP1067-144	14-1067	EXTERNAL	GREASABLE	2800	550	ROUND	ORGANIC		10	X		7"
S-E427	LP1072-134	14-1072	EXTERNAL	GREASABLE	2000	550	ROUND	ORGANIC		10	X		7"
S-E428	LP1686-138	14-1686	EXTERNAL	GREASABLE	2300	500	4-PADDLE	CERAMIC	VTL	10	X		7"
350MM X 1 1/2" SINGLE PLATE PUSH TYPE													
S-C372	107621-1	102048	EXTERNAL	GREASABLE	2400	500	4-PADDLE	CERAMIC	VSR	8	X		7"
S-E429	107621-7	102048	EXTERNAL	GREASABLE	2400	500	4-PADDLE	CERAMIC	VSR	8	X		7"
14" X 1 1/2" STAMPED STEEL SINGLE PLATE													
S-8295	107688-7	129710-3	EASE-A-JUST	GREASABLE	2400	520	4-PADDLE	CERAMIC	VSR	8	X		7"
14" X 1 3/4" STAMPED STEEL SINGLE PLATE													
S-8296	107113-7	127747-2	MANUAL	GREASABLE	2800	445	ROUND	CERAMIC	VSR	8	X		7"
S-8297	107113-5	127747-2	MANUAL	GREASABLE	2800	650	4-PADDLE	CERAMIC	VSR	8	X		7"
S-E432	107683-5	127747-1	MANUAL	GREASABLE	3200	650	3-PADDLE	CERAMIC	VTL	8	X		7"
S-E433	107683-16	127747-1	MANUAL	GREASABLE	3200	445	ROUND	ORGANIC		8	X		7"
S-E434	107683-5	129044-1	EASE-A-JUST	GREASABLE	3200	650	3-PADDLE	CERAMIC	VTL	8	X		7"
14" X 1 3/4" STAMPED STEEL TWO PLATE													
S-8299	107137-5	129044-2	MANUAL	GREASABLE	2800	900	3-PADDLE	CERAMIC	VSR	8	X		7"
S-8298	107137-6	129044-2	MANUAL	GREASABLE	2800	800	ROUND	ORGANIC		8	X		7"
S-C580	107237-8	129060-5	EASE-A-JUST	GREASABLE	2000	900	3-PADDLE	CERAMIC	VTL	8		X	7"
S-E430	107137-8	129044-5	MANUAL	GREASABLE	2000	900	3-PADDLE	CERAMIC	VTL	8		X	7"
S-E599	107237-16	129060-2	EASE-A-JUST	GREASABLE	2800	800	ROUND	ORGANIC		8	X		7"
14" X 2" STAMPED STEEL TWO PLATE													
S-8301	107142-3	129055-2	MANUAL	GREASABLE	2800	800	ROUND	ORGANIC		8	X		7"
S-8302	107142-2	129055-2	MANUAL	GREASABLE	2800	900	3-PADDLE	CERAMIC	VSR	8	X		7"
S-E600	107342-11	129061-5	EASE-A-JUST	GREASABLE	2000	900	3-PADDLE	CERAMIC	VTL	8		X	7"

NEW "SOFT PEDAL" CLUTCH ASSEMBLIES

- STATE-OF-THE-ART DIAPHRAGM SPRING DESIGN
- TRADITIONAL MANUAL ADJUSTMENT
- SMOOTHER ENGAGEMENT
- NO METAL WEAR TO CAUSE INTERNAL FRICTION
- STRAP DRIVE FOR SMOOTHER TRANSFER OF ENERGY
- 30% LESS BEARING LOAD WITH PEDAL PRESSURE REDUCTION
- LESS DRIVER FATIGUE AND IMPROVED PRODUCTIVITY
- INCREASED COVER VENTILATION FOR BETTER HEAT DISSIPATION

NEW STAR NUMBER	REPLACEMENT FOR — DANA® NUMBER	REPLACEMENT FOR — COVER ASSEMBLY NUMBER	ADJUSTMENT TYPE	BEARING TYPE	PLATE LOAD POUNDS	TORQUE RATING (ft/lbs)	CARRIER STYLE	FRICTION MATERIAL	CERAMIC CONFIG	NUM OF SPRINGS	CONVENTIONAL	FREE TRAVEL	MIN. FLYWHEEL OPENING
14" X 1 3/4" SOFT PEDAL													
S-E437	108063-59	160051-1	MANUAL	GREASABLE	3200	1150	4-PADDLE	CERAMIC	VSR	8	X		7"
14" X 2" SOFT PEDAL													
S-D575	108034-61	160051-1	MANUAL	GREASABLE	3200	1150	3-PADDLE	CERAMIC	VSR	8	X		7"
S-D574	108050-59	160051-1	MANUAL	GREASABLE	3200	1400	4-PADDLE	CERAMIC	VSR	8		X	7"
S-E439	108950-59	160051-1-M	MANUAL	GREASABLE	3200	1400	4-PADDLE	CERAMIC	VSR	8		X	7"
15 1/2" X 2" SOFT PEDAL													
S-E440	108391-82	152705-6	MANUAL	GREASABLE	4000	1350	ROUND	ORGANIC		8		X	7"
S-C308	108391-78B	152705-6	MANUAL	GREASABLE	4000	1400	ROUND	ORGANIC		10	X		8.5"
S-C309	108391-81B	152705-4	MANUAL	GREASABLE	3600	1450	4-PADDLE	CERAMIC	VSR	8		X	7"
S-C310	108391-74B	152705-4	MANUAL	GREASABLE	3600	1650	4-PADDLE	CERAMIC	VSR	10	X		8.5"
S-E441	108391-93B	152705-6	MANUAL	GREASABLE	4000	1850	6-PADDLE	CERAMIC	VSR	10	X		8.5"
S-C311	108925-82B	151455-4	MANUAL	GREASABLE	3600	1700	4-PADDLE	CERAMIC	VSR	7		X	10"
S-E442	108935-51	151455-4-M	MANUAL	GREASABLE	3600	1650	4-PADDLE	CERAMIC	VSR	9	X		10"
S-C697	108935-91	151455-4-M	MANUAL	GREASABLE	3600	1700	6-PADDLE	CERAMIC	VSR	9	X		10"
S-E443	108935-94	151455-6-M	MANUAL	GREASABLE	4000	1850	6-PADDLE	CERAMIC	VSR	9	X		10"

CLUTCH



CLUTCH INSTALLATION KIT FOR HEAVY DUTY FULLER APPLICATIONS K2336, K2468, and K3600

CONTAINS CLUTCH FORK, SNAP RINGS,
BEARINGS, BUSHINGS, RETAINER,
GASKET SET AND INPUT SHAFT



CLUTCH ALIGNMENT TOOLS

NOW OFFERING TOOLS TO HELP ELIMINATE IMPROPER CLUTCH ALIGNMENT



MADE IN THE U.S.A.

NEW★STAR CLUTCH ALIGNMENT TOOLS ALLOW DISC SPLINES TO BE EASILY ALIGNED TO THE PILOT BEARING.

NEW★STAR NUMBER	DESCRIPTION
S-E343	1 3/8" SPLINE X 1" PILOT
S-E344	1 1/2" SPLINE X 1" PILOT
S-E345	1 1/2" SPLINE X 3/4" PILOT
S-E346	1 1/2" SPLINE X 1.18" PILOT
S-E347	1 3/4" SPLINE X 1" PILOT
S-E348	1 3/4" SPLINE X 1.18" PILOT
S-E349	2" SPLINE X 1.18" PILOT

THE SHAPE OF THE CLUTCH ALIGNMENT TOOLS FOLLOW THE PROFILE OF THE ACTUAL INPUT SHAFT.

DUE TO A SPECIALLY MOLDED PLASTIC MATERIAL, CLUTCH ALIGNMENT TOOLS CAN BE USED OVER AND OVER AGAIN.

ENSURE CORRECT ADJUSTMENT FOR PROPER CLUTCH OPERATION



NEW★STAR NO. S-E337

1/8" GAUGE

CHECKS THE 1/8" CLUTCH PEDAL FREE PLAY BETWEEN THE YOKE AND BEARING WEAR PAD



NEW★STAR NO. S-E338

1/2" GAUGE

VERIFIES THE 1/2" RELEASE TRAVEL BETWEEN THE RELEASE BEARING AND THE TRANSMISSION BEARING CAP



NEW★STAR NO. S-E339

TOOL KIT FOR BOTH GAUGES

CLUTCH ALIGNMENT TOOLS

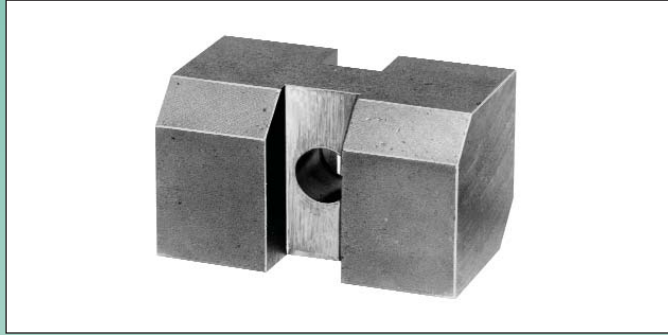

NEW★STAR NO. S-A362

DRIVE LUG ALIGNMENT TOOL



NEW★STAR NO. S-A356

CLUTCH ADJUSTING TOOL

ENSURE CORRECT ADJUSTMENT FOR PROPER CLUTCH OPERATION

REPLACEMENT NUMBER: 7028

DID YOU KNOW **NEW★STAR** NOW
OFFERS REPLACEMENT PTO'S TOTALLY
INTERCHANGEABLE WITH CHELSEA™ FOR MOST
POPULAR ALLISON, FULLER, MACK, MERITOR
AND TTC TRANSMISSIONS

HINGED LOCKING CLUTCH BRAKE

REPLACE WORN OR DAMAGED CLUTCH BRAKES
WITHOUT REMOVING THE TRANSMISSION

HINGED CLUTCH BRAKE:

THE PURPOSE OF THE CLUTCH BRAKE IS TO SLOW DOWN OR STOP THE TRANSMISSION INPUT SHAFT FROM ROTATING WHEN THE CLUTCH PEDAL IS DEPRESSED.

NOW, WITH THE **NEW★STAR** HINGED LOCKING CLUTCH BRAKE, YOU CAN REPLACE WORN OR DAMAGED CLUTCH BRAKES WITHOUT REMOVING THE TRANSMISSION.

THE HINGED LOCKING BRAKE, WITH IT'S EASY INSTALLATION, (SECURED WITH A BOLT) NOT ONLY SAVES TIME AND MONEY, BUT ALSO PROVIDES EFFORTLESS ENGAGEMENT AND COOLER OPERATION.

5/32" ALLEN WRENCH IS NEEDED FOR INSTALLATION. (NOT INCLUDED)

INSTALLATION SUGGESTION - USE A DROP OF LOCKTITE® ON THE BOTTOM OF THE THREAD



NEW★STAR
NUMBER

HINGED CLUTCH BRAKES

S-15475	2" (.380" THICK)
S-16422	2" (.450" THICK)
S-16423	2" (.500" THICK)
S-16424	2" (.550" THICK)
S-16425	1 3/4" (.380" THICK)

LATEST ADDITIONS TO OUR CATALOG

EXCEPT WHERE SPECIFIED, ALL PARTS SUPPLIED ARE S&S/NEWSTAR. USE OF OTHER MANUFACTURERS' NAMES, PART NUMBERS, OR TRADEMARKS ARE FOR INFORMATIONAL AND IDENTIFICATION PURPOSES ONLY.

CLUTCH BRAKES

SUITABLE FOR 14" and 15 1/2" 2 PLATE CLUTCH ASSEMBLIES



1 3/4" TORQUE LIMITING BRAKE

NEW★STAR NO. S-B038

REPLACEMENT FOR
DANA® NUMBER: 127740

2" TORQUE LIMITING BRAKE

NEW★STAR NO. S-B039

REPLACEMENT FOR
DANA® NUMBER: 127760



1 3/4" NON-TORQUE LIMITING BRAKE

NEW★STAR NO. S-8801

REPLACEMENT FOR
DANA® NUMBER: 127740X

2" NON-TORQUE LIMITING BRAKE

NEW★STAR NO. S-8802

REPLACEMENT FOR
DANA® NUMBER: 127760X

CLUTCH BELL HOUSING COVER KITS AND HOSES

STOP THE INTRODUCTION OF DANGEROUS CONTAMINANTS INTO THE CLUTCH BELL HOUSING.

NEW★STAR OFFERS A VARIETY OF BELL HOUSING COVER KITS AND HOSES TO MEET THE SPECIFIC NEEDS OF YOUR CUSTOMERS. **NEW★STAR** HAS CREATED A RUBBER PLUG THAT ALLOWS THE PASSAGE OF THE GREASE HOSE WHILE SEALING THE OVERSIZE HOLE IN THE BELL HOUSING COVER. THE SEALING DISCOURAGES THE ENTRY OF CONTAMINANTS.

THESE ASSEMBLIES REPLACE THE OE NUMBER 4305230 AND INCLUDE THE COVER, PLUG, MOUNTING SCREW, LOCK WASHERS AND VARYING HOSE LENGTHS FROM 6" TO 12".

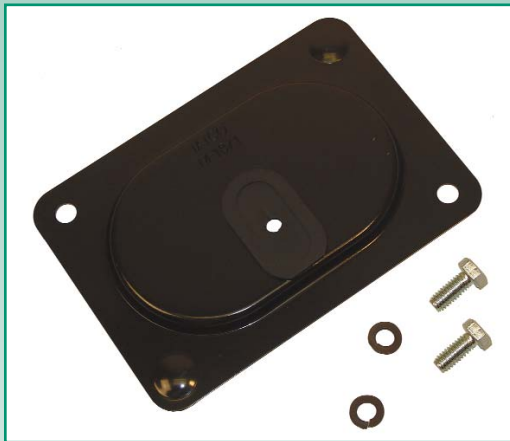

NEW★STAR NUMBER	REPLACEMENT NUMBER	
S-13196	4305230	NO HOSE INCLUDED
S-16426	4305230A6P	6" HOSE
S-16427	4305230A7P	7" HOSE
S-16428	4305230A8P	8" HOSE
S-16429	4305230A9P	9" HOSE
S-16430	4305230A12P	12" HOSE



NEW★STAR NUMBER	REPLACEMENT NUMBER	
S-16431	CLT006P	6" HOSE
S-16432	CLT007P	7" HOSE
S-16433	CLT008P	8" HOSE
S-16434	CLT009P	9" HOSE
S-16435	CLT0012P	12" HOSE
S-16436	4305230RP	RUBBER PLUG

LATEST ADDITIONS TO OUR CATALOG

EXCEPT WHERE SPECIFIED, ALL PARTS SUPPLIED ARE S&S/NEWSTAR. USE OF OTHER MANUFACTURERS' NAMES, PART NUMBERS, OR TRADEMARKS ARE FOR INFORMATIONAL AND IDENTIFICATION PURPOSES ONLY.

CLUTCH PARTS

SLEEVE AND BEARING ASSEMBLIES

SLEEVE AND BEARING ASSEMBLY

FREIGHTLINER APPLICATION
SUITABLE FOR USE DANA® PART NUMBER: 107621-7

NEW★STAR NO. S-D802

REPLACEMENT FOR FREIGHTLINER NUMBER:
187140 / SP187140



SLEEVE AND BEARING ASSEMBLY

INTERNATIONAL TRUCK APPLICATION
SUITABLE FOR USE DANA® PART NUMBER: 107621-1

NEW★STAR NO. S-9208

REPLACEMENT FOR INTERNATIONAL TRUCK NUMBER:
572107C91



SLEEVE AND BEARING ASSEMBLY

MACK MIDLINER APPLICATION
SUITABLE FOR USE DANA® PART NUMBER: 107350-4

NEW★STAR NO. S-D801

REPLACEMENT FOR MACK NUMBER:
187144 / 2104-187144



CLUTCH PARTS

SUITABLE FOR 14" and 15 1/2" 2 PLATE CLUTCH ASSEMBLIES



NEW STAR NUMBER	REPLACEMENT FOR DANA® NUMBER	DESCRIPTION	BORE	O.D.	WIDTH
S-7440	105C-137	FORK			
S-9110	106C-939	RELEASE SHAFT 10"			
S-5910	106C-1047	RELEASE SHAFT 9 1/2"			
S-5911	106C-1094	RELEASE SHAFT 8 1/2"			
S-4221	106C-1185	RELEASE SHAFT 5 3/4"			
S-3347	106C-1498	RELEASE SHAFT 6 1/2"			
S-7660	274C-6	DRIVE PIN			
S-5504	6205-2RS	PILOT BEARING	0.9843	2.047	0.5906
S-10463	6206-2RS	PILOT BEARING	1.1811	2.4409	0.6299
S-11672	6305-2RS	PILOT BEARING	0.9843	2.4409	0.6693
S-5940	6306-2RS	PILOT BEARING	1.1811	2.8346	0.748
S-A357	127859	2"- 2 PLATE SLEEVE WITH BEARING			
S-A358	127860	1 3/4"- 2 PLATE SLEEVE WITH BEARING			
S-A405	127889	1 3/4"- 1 PLATE SLEEVE WITH BEARING			
S-A359	127389	1 3/4"- 2 PLATE SLEEVE			
S-A360	127393	2"- 2 PLATE SLEEVE			
S-A361	127857	1 3/4"- 1 PLATE SLEEVE			

CLUTCH PARTS

HIGH TEMPERATURE PILOT BEARING

HIGH TEMPERATURE “FLOURINE” SEALS ARE AN IMPROVED VERSION OF VITON MATERIAL.

HIGH TEMPERATURE GREASE IS SPECIALLY FORMULATED TO INCREASE PRODUCT LIFE, EXCEEDING THE ENGINE MANUFACTURER’S REQUIREMENTS

C5 INTERNAL CLEARANCE ACCOMMODATES THE NEW GUIDELINES FROM ENGINE MANUFACTURERS AND INCREASES PRODUCT LIFE.

LARGE BALL DIAMETERS RESULTS IN LARGER DYNAMIC RADIAL LOAD RATING THAN SIMILAR PRODUCTS ON THE MARKET.

IDEAL FOR TODAY’S HIGH TORQUE ENGINES THAT OPERATE AT A LOWER RPM AND HAVE A HIGHER OPERATING TEMPERATURE.



NEWSTAR NUMBER	REPLACEMENT NUMBER	
S-16421	6306-2RS2/C5-HT	2.833: X 1.179"

REPLACEMENT FLYWHEEL

APPLICATION: INTERNATIONAL TRUCK AND MACK TRUCKS



NEW STAR NUMBER	REPLACEMENT FOR PART NUMBER	ENGINE MODEL
S-3239	681905C93	USE 1810855C93
S-A856	1809144C91	7.3 LITER ENGINES
S-A608	1810855C93	DT 466 14" CLUTCH ONLY
S-10006	1818214C91	7.3 LITER ENGINES / 444E
S-10005	1821915C91	DT 466E
S-10010	530-GB-3142	675 / 676

REPLACEMENT CLUTCH HOUSING BRACKET PARTS

APPLICATION: MACK TRUCKS



NEW STAR NUMBER	REPLACEMENT FOR MACK NUMBER	DESCRIPTION	REPLACEMENT FOR PAI NUMBER
S-D517	1-AX-127	BOLT, CLUTCH HOUSING	9597
S-8408	1-AX-503	BOLT	4601
S-7622	21-AX-440	NUT	4605
S-8410	15-QD-1132	WASHER	4595
S-8056	20-QL-1118-A	INSULATOR	4670
S-8750	36-RU-171	LUBE HOSE 15" LONG	4159
S-9711	36-RU-171-KIT	LUBE HOSE KIT	—
S-8473	204-SX-216	INSULATOR KIT	4603
S-D521	204-SX-389	INSULATOR KIT	5069

REPLACEMENT RING GEAR and PINION SETS

APPLICATION: ARVIN MERITOR AXLES



NEW STAR NUMBER	REPLACEMENT FOR PART NUMBER	DESCRIPTION	APPLICATION - MODEL
S-A117	A-34712	GEAR SET 5.14	53589
S-16549	A-34814-16	GEAR SET 5.57	TA173
S-A839	A-35136-12	GEAR SET RR 5.29	SEE A-40674-1
S-13008	A-35136-18	GEAR SET RR 5.29	SHR (DIRONA)
S-9092	A-35156-8	GEAR SET RR 6.17	SEE A-40678-1
S-9092	A-35156-9	GEAR SET RR 6.17	SEE A-40678-1
S-D601	A-35166-9	GEAR SET RR 7.40	SEE A-40682-1
S-6890	A-35178-5	GEAR SET RR 4.11	SHR, R155
S-6891	A-35178-10	GEAR SET RR 4.11	SEE A-40536-1
S-A175	A-35208-10	GEAR SET RR 4.63	SEE A-40544-1
S-7294	A-35376-6	GEAR SET	SFD-4640,FWD & RR 6.58,8.07-9.02-10.16-11.56
S-8574	A-35514-6	GEAR SET 5.83	D100, DHR
S-7295	A-35536-6	GEAR SET 7.20	F106,147
S-6895	A-35538-10	GEAR SET 6.80	F106,147
S-6896	A-35540-5	GEAR SET 6.20	F106,147
S-16008	A-35614-1	GEAR SET 5.29	Q100, 145 SINGLE AXLE
S-6898	A-35634-6	GEAR SET RR 7.80	D100,140
S-6899	A-35710-3	GEAR SET 5.29	F106
S-15663	A-35778-9	GEAR SET 5.29	H, L172
S-7589	A-35804-19	GEAR SET RR 7.20	SQHD
S-2172	A-35808-19	GEAR SET RR 6.17	SQHD
S-7305	A-35808-22	GEAR SET FWD 6.17	SQHD
S-7306	A-35808-23	GEAR SET FWD 6.17	SQHD
S-7309	A-35810-19	GEAR SET 5.83	SQHD
S-7311	A-35812-17	GEAR SET FWD 5.29	SEE A-35812-20
S-7312	A-35812-18	GEAR SET RR 5.29	SQHD
S-7313	A-35812-20	GEAR SET FWD 5.29	SQHD
S-7314	A-35812-21	GEAR SET FWD 5.29	SQHD
S-7315	A-35814-13	GEAR SET FWD 4.63	SEE A-35814-16
S-7317	A-35814-16	GEAR SET FWD 4.63	SQHD
S-7318	A-35814-17	GEAR SET FWD 4.63	SQHD
S-7321	A-35816-16	GEAR SET FWD 4.44	SEE A-35816-19
S-7320	A-35816-17	GEAR SET RR 4.44	SQHD
S-7321	A-35816-19	GEAR SET FWD 4.44	SQHD
S-7322	A-35816-20	GEAR SET FWD 4.44	SQHD
S-7325	A-35818-19	GEAR SET FWD 4.11	SEE A-35818-23
S-7324	A-35818-20	GEAR SET RR 4.11	SQHD
S-7325	A-35818-23	GEAR SET FWD 4.11	SQHD
S-7326	A-35818-24	GEAR SET FWD 4.11	SQHD
S-7327	A-35838-6	GEAR SET FWD 4.11	SEE A-40164-1
S-6901	A-35910-5	GEAR SET FWD 4.63	SEE A-40172-1
S-6902	A-35912-5	GEAR SET FWD 5.29	SEE A-40178-1
S-13409	A-35912-15	GEAR SET FWD 5.29	SSHD (DIRONA)

DIFFERENTIAL



LATEST ADDITIONS TO OUR CATALOG

EXCEPT WHERE SPECIFIED, ALL PARTS SUPPLIED ARE S&S/NEWSTAR. USE OF OTHER MANUFACTURERS' NAMES, PART NUMBERS, OR TRADEMARKS ARE FOR INFORMATIONAL AND IDENTIFICATION PURPOSES ONLY.

REPLACEMENT RING GEAR and PINION SETS

APPLICATION: ARVIN MERITOR AXLES

NEW STAR NUMBER	REPLACEMENT FOR PART NUMBER	DESCRIPTION	APPLICATION - MODEL
S-6903	A-35916-2	GEAR SET FWD 6.17	SEE A-40182-1
S-3708	A-35954	GEAR SET 3.70	R-170
S-6904	A-35958-1	GEAR SET 6.50	H162,L145
S-6904	A-35958-3	GEAR SET 6.50	H162,L145
S-2313	A-36028-18	GEAR SET RR 3.55	SQHD
S-13024	A-36054	GEAR SET 5.86	R170
S-8287	A-36100	GEAR SET 7.40	R-170
S-13254	A-36162-1	GEAR SET 5.83	F SERIES
S-7328	A-36446-13	GEAR SET RR 4.88	SQHD
S-A176	A-36684-3	GEAR SET FWD 4.88	SEE A-40176-1
S-7333	A-36722-9	GEAR SET FWD 4.33	SEE A-36722-12
S-7333	A-36722-12	GEAR SET FWD 4.33	SQHD
S-3524	A-36722-13	GEAR SET FWD 4.33	SQHD
S-A948	A-36736	GEAR SET 7.20	13168/HYSTER
S-C387	A-36950-3	GEAR SET 7.17	H-170
S-16021	A-37024-8	GEAR SET 3.70	SR, SU, SW170, 270
S-9805	A-37090-1	GEAR SET FWD 6.80	F051600
S-9305	A-37164	GEAR SET FWD 4.33	SEE A-40170-1
S-5382	A-37278-2	GEAR SET FWD 3.55	SQHP,SQ100
S-15179	A-37308-1	GEAR SET RR 7.17	LR100, QR100
S-7590	A-37326-1	GEAR SET RR 3.55	LR,QR100
S-8518	A-37376-1	GEAR SET RR 5.29	QR-100
S-9633	A-37382-1	GEAR SET RR 4.33	LR100/QR100
S-8665	A-37392-1	GEAR SET RR 4.88	LR100/QR100
S-6906	A-37396-2	GEAR SET FWD 5.29	SQHP,QD100
S-8654	A-37398-1	GEAR SET FWD 4.88	SQ100/SQHP
S-6907	A-37404-1	GEAR SET FWD 4.33	SQHP,QD100
S-7304	A-37494-2	GEAR SET FWD 4.11	SEE A-38836-1
S-6908	A-37530-2	GEAR SET FWD 4.44	SQHP,QD100
S-6910	A-37534-3	GEAR SET RR 4.63	QAR
S-6911	A-37536-3	GEAR SET RR 5.29	QAR
S-6912	A-37540-2	GEAR SET FWD 4.63	QHP,QD100
S-14107	A-37564-1	GEAR SET RR 4.44	LR100, QR100
S-9634	A-37566-1	GEAR SET RR 4.63	LR100/QR100
S-6915	A-37588-9	GEAR SET FWD 3.70	SEE A-37588-12
S-7335	A-37588-10	GEAR SET RR 3.70	SQHD
S-6915	A-37588-12	GEAR SET FWD 3.70	SQHD
S-7336	A-37588-13	GEAR SET FWD 3.70	SQHD
S-7337	A-37596-2	GEAR SET FWD 3.70	SQHP
S-7338	A-37598-3	GEAR SET RR 3.70	SQHP
S-8358	A-37890-2	GEAR SET FWD 3.90	SEE A-40162-1
S-7718	A-38002-1	GEAR SET FWD 3.90	SQHP,SQ100
S-6916	A-38006-1	GEAR SET FWD 3.90	SEE A-38006-9
S-6916	A-38006-9	GEAR SET FWD 3.90	LHD/QHD
S-7339	A-38006-10	GEAR SET FWD 3.90	SQHD
S-A208	A-38512-1	GEAR SET RR 3.70	LR100/QR100
S-8226	A-38520-1	GEAR SET RR 3.90	LR100,QR100
S-7340	A-38586-5	GEAR SET RR 3.73	SEE A-40504-5
S-9844	A-38730-1	GEAR SET RR 4.10	LR,QR100
S-13029	A-38774-4	GEAR SET FWD 4.10	RS-13-210,15-120-125
S-6891	A-38806-1	GEAR SET RR 4.10	SEE A-40536-1
S-7327	A-38808-1	GEAR SET FWD 4.10	SEE A-40164-1
S-A576	A-38836-1	GEAR SET FWD 4.11	SQ100,SQHP
S-7913	A-39004-1	GEAR SET RR 5.38	SEE A-40088-1
S-7914	A-39016-1	GEAR SET FWD 5.38	SEE A-40046-1
S-8227	A-39166-1	GEAR SET RR 3.73	QAR

LATEST ADDITIONS TO OUR CATALOG

EXCEPT WHERE SPECIFIED, ALL PARTS SUPPLIED ARE S&S/NEWSTAR. USE OF OTHER MANUFACTURERS' NAMES, PART NUMBERS, OR TRADEMARKS ARE FOR INFORMATIONAL AND IDENTIFICATION PURPOSES ONLY.



REPLACEMENT RING GEAR and PINION SETS

APPLICATION: ARVIN MERITOR AXLES

NEW STAR NUMBER	REPLACEMENT FOR PART NUMBER	DESCRIPTION	APPLICATION - MODEL
S-7591	A-39168-1	GEAR SET RR 3.73	LR,QR100
S-7588	A-39170-1	GEAR SET FWD 3.73	SQHP,SQ100
S-8521	A-39424-1	GEAR SET RR 3.42	LR-QR-100
S-9632	A-39446-1	GEAR SET FWD 3.42	QD100,SQ100,QHP
S-8439	A-39496-3	GEAR SET FWD 7.17	RS-13-120,RS-15-120
S-13172	A-39660-1	GEAR SET FWD 3.58	RD, RP-23-160
S-C405	A-39664-1	GEAR SET FWD 4.89	RD, RP-23-160
S-11665	A-39666-1	GEAR SET FWD 5.38	RD, RP-23-160
S-C049	A-39880-1	GEAR SET FWD 4.30	RD, RP-23-160
S-C050	A-39882-1	GEAR SET FWD 4.56	RD, RP-23-160
S-C406	A-39884-6	GEAR SET RR 3.91	RR, RS23-160
S-10042	A-39886-5	GEAR SET RR 4.10	RR, RS23-160
S-A818	A-39888-5	GEAR SET RR 4.30	RR,RS-23-160,RT-46-160
S-15619	A-39888-6	GEAR SET RR 4.30	RS23-160
S-A819	A-39890-5	GEAR SET RR 4.56	RR,RS-23-160,RT-46-160
S-13168	A-39904-5	GEAR SET RR 3.58	RR, RS-23-160
S-11779	A-39906-5	GEAR SET RR 3.73	RR, RS23-160
S-9448	A-40036-1	GEAR SET FWD 4.56	R164-SSHD
S-7914	A-40046-1	GEAR SET FWD 5.38	SHD,THD,UHD
S-9449	A-40074-1	GEAR SET RR 4.56	SHR,R155
S-7913	A-40088-1	GEAR SET RR 5.38	SHR,R155
S-11470	A-40104-5	GEAR SET RR 5.38	RR-RS-23-160
S-10105	A-40106-1	GEAR SET RR 5.63	RR,RS-23-160
S-13491	A-40110-5	GEAR SET RR 6.14	RR, RS23-160
S-13685	A-40160-1	GEAR SET FWD 3.73	SSHD
S-8358	A-40162-1	GEAR SET FWD 3.90	SSHD
S-7327	A-40164-1	GEAR SET FWD 4.11	SSHD
S-9305	A-40170-1	GEAR SET FWD 4.33	SSHD
S-6901	A-40172-1	GEAR SET FWD 4.63	SSHD
S-A176	A-40176-1	GEAR SET FWD 4.88	SHD,THD,UHD
S-6902	A-40178-1	GEAR SET FWD 5.29	SSHD
S-A621	A-40180-1	GEAR SET FWD 5.57	SHD,THD,UHD
S-6903	A-40182-1	GEAR SET FWD 6.17	SSHD
S-A804	A-40306-1	GEAR SET FWD 6.83	SHD,THD,UHD
S-7566	A-40504-1	GEAR SET RR 3.73	SHR,R155
S-7340	A-40504-5	GEAR SET RR 3.73	R140,143
S-9426	A-40534-1	GEAR SET RR 3.90	SHR,R155
S-6891	A-40536-1	GEAR SET RR 4.11	SHR
S-9621	A-40542-1	GEAR SET RR 4.33	SHR,R155
S-A175	A-40544-1	GEAR SET RR 4.63	SHR,R155
S-A839	A-40674-1	GEAR SET RR 5.29	SHR,R155
S-7290	A-40674-6	GEAR SET RR 5.29	SHR, R155
S-9092	A-40678-1	GEAR SET RR 6.17	R155,R140,SHR,UHR
S-A509	A-40680-1	GEAR SET RR 6.83	SHR,R155
S-D601	A-40682-1	GEAR SET RR 7.40	SHR,R155
S-7293	A-40682-5	GEAR SET RR 7.40	SHR,R155
S-A328	A-40686-1	GEAR SET RR 3.33	SHR,R155
S-13286	A-41104-1	GEAR SET FWD 2.93	RD-RP-20-145
S-13381	A-41158-1	GEAR SET FWD 2.93	RR20-145, 22-145, RS21-145
S-11809	A-41272-1	GEAR SET FWD 5.13	RS-21-145
S-13097	A-41458-1	GEAR SET RR 6.14	RR-20-145,RS-21-145
S-11835	A-41460-1	GEAR SET RR 6.43	RR-20-145,RS-21-145
S-16020	A-41460-3	GEAR SET RR 5.86	RR20-145, 22-145, RS22-145
S-D798	A-41462-1	GEAR SET RR 6.83	RR-20-145,RS-21-145
S-13604	A-41464-1	GEAR SET RR 7.17	RR20-145, 22-145, RS21-145
S-15279	A-41468-1	GEAR SET FWD 6.14	RD, RP20-145, 22-145

DIFFERENTIAL



LATEST ADDITIONS TO OUR CATALOG

EXCEPT WHERE SPECIFIED, ALL PARTS SUPPLIED ARE S&S/NEWSTAR. USE OF OTHER MANUFACTURERS' NAMES, PART NUMBERS, OR TRADEMARKS ARE FOR INFORMATIONAL AND IDENTIFICATION PURPOSES ONLY.

REPLACEMENT RING GEAR and PINION SETS

APPLICATION: ARVIN MERITOR AXLES

NEW STAR NUMBER	REPLACEMENT FOR PART NUMBER	DESCRIPTION	APPLICATION - MODEL
S-12045	A-41470-1	GEAR SET FWD 6.43	RD, RP-20-145, 22-145
S-D799	A-41472-1	GEAR SET FWD 6.83	RD, RP-20-145, 22-145
S-11836	A-41474-1	GEAR SET FWD 7.17	RD, RP20-145, 22-145
S-11198	A-41496-1	GEAR SET RR 3.21	RR-20-145, RS-21-145
S-11199	A-41510-1	GEAR SET FWD 3.21	RD, RP20-145, 22-145
S-F182	A-41586-1	GEAR SET RR 3.36	SHR,R155
S-13232	A-41676-1	GEAR SET FWD 2.79	RD,RP-20-145
S-14110	A-41682-1	GEAR SET RR 2.79	RS, RR-20-145
S-11573	B-41008-3	GEAR SET RR 4.56	RS-23-180, RR, RS180
S-15742	B-41014-3	GEAR SET RR 4.30	RS-23-180, RR, RS180
S-A601	B-41016-4	GEAR SET RR 3.73	RR-28-160
S-14682	B-41018-3	GEAR SET RR 4.10	RS-23-180, RR, RS180
S-13924	B-41028-3	GEAR SET FWD 5.38	RS-23-180, RR, RS180
S-13417	B-41030-3	GEAR SET RR 3.58	RS-23-180, RR, RS180
S-15341	B-41034-3	GEAR SET RR 4.89	RS-23-180, RR, RS180
S-D554	B-41164-1	GEAR SET RR 3.42	RR-20-145,RS-21-145
S-D793	B-41266-1	GEAR SET RR 4.33	RR22-145
S-D794	B-41268-1	GEAR SET RR 4.63	RR22-145
S-D795	B-41270-1	GEAR SET RR 4.88	RR22-145
S-D796	B-41274-1	GEAR SET RR 5.29	RR22-145
S-D797	B-41276-1	GEAR SET FWD 3.42	RD, RP22-145
S-8815	B-41278-1	GEAR SET FWD 4.33	RD,RP-20-145,RD,RP-22-145
S-D425	B-41280-1	GEAR SET FWD 4.63	RD-22-145
S-B453	B-41282-1	GEAR SET FWD 4.88	RD-RP-22-145
S-C187	B-41284-1	GEAR SET FWD 5.29	RD-RP-22-145
S-14085	B-41456-1	GEAR SET RR 5.86	RR22-145
S-11469	B-41466-1	GEAR SET FWD 5.86	RD, RP22-145
S-E786	B-41498-1	GEAR SET RR 3.58	RR-22-415
S-D800	B-41500-1	GEAR SET RR 3.73	RR22-145
S-9377	B-41504-1	GEAR SET RR 4.10	SEE B-41686-1
S-B454	B-41512-1	GEAR SET FWD 3.58	RD-RP-22-145
S-C188	B-41514-1	GEAR SET FWD 3.73	RD-RP-22-145
S-C437	B-41532-1	GEAR SET RR 3.58	RR-22-145
S-C438	B-41534-1	GEAR SET RR 3.73	RR-22-145
S-9377	B-41538-1	GEAR SET RR 4.11	SEE B-41686-1
S-9180	B-41540-1	GEAR SET RR 4.33	RR-22-145,RR-20-145,RS-21-145,RT-40-145
S-9376	B-41542-1	GEAR SET RR 4.56	RR-20-145,RT-40-145,RS-21-145
S-C182	B-41544-1	GEAR SET RR 4.88	RR-22-145,20-145,21-145,40-145
S-C368	B-41548-1	GEAR SET RR 5.29	RR-22-145
S-11533	B-41552-1	GEAR SET RR 5.86	RR-22-145
S-11915	B-41554-1	GEAR SET RR 6.14	RR-22-145
S-9392	B-41562-1	GEAR SET FWD 4.56	RD,RP-22-145
S-A949	B-41678-1	GEAR SET FWD 3.90	RD,RP-22-145,20-145,RT-40-145
S-A950	B-41680-1	GEAR SET FWD 4.11	RD,RP-22-145,20-145,RT-40-145
S-A951	B-41684-1	GEAR SET RR 3.90	RR-22-145
S-9377	B-41686-1	GEAR SET RR 4.11	RR-22-145,RR-RS-20-145

LATEST ADDITIONS TO OUR CATALOG

EXCEPT WHERE SPECIFIED, ALL PARTS SUPPLIED ARE S&S/NEWSTAR. USE OF OTHER MANUFACTURERS' NAMES, PART NUMBERS, OR TRADEMARKS ARE FOR INFORMATIONAL AND IDENTIFICATION PURPOSES ONLY.



REPLACEMENT GEARS AND PARTS

APPLICATION: ARVIN MERITOR AXLES

NEWSTAR NUMBER	REPLACEMENT FOR PART NUMBER	DESCRIPTION	APPLICATION - MODEL
S-8171	NL-110-1	NUT	SQHD,SLHD,SQHP,SL,SQ100
S-6931	S-249	2 PC GEAR KIT	SLHD,SQHD,FIN LOTS OF 10 OR MORE
S-D535	5-X-591	O-RING	SSHD,STHD,SUHD
S-A322	5-X-1034	O-RING	RT-34-145,40-140,40-145P,44-145,46-140, 46-160,52-160
S-A212	40-X-1145	METRIC NUT	RT-34-145,40-140,40-145,46-160
S-F216	40-X-1150	METRIC NUT	RR-20-145,22-145,RS-17-140,21-145,RS-23-160
S-A973	40-X-1233	METRIC NUT	RT-46-160,52-160,RS-23-160,161,26-160
S-A971	40-X-1236	METRIC NUT	RS-16-140,17-140
S-A213	40-X-1237	METRIC NUT	RD-20-145,RT-40-145
S-D555	41-X-1327	METRIC BOLT, MAIN CASE	RS-21-145,RT-34-145,40-145,44-145
S-14003	KIT-306	GEAR KIT	R120, 140, 155 BUS
S-6951	315	GEAR KIT	SLHD
S-6952	316	GEAR KIT	SQHD
S-6953	317	GEAR KIT	SLHD
S-6954	318	GEAR KIT	SQHD
S-7341	322	GEAR KIT	SLHD,SQHD
S-6955	325	GEAR KIT	SQHP,SQ100,P
S-6956	326	GEAR KIT	SQHP,SQ100,P
S-7694	327	GEAR KIT	SSHD,STHD,SUHD
S-7696	339	GEAR KIT	D,F MODELS
S-7695	347	GEAR KIT	SSHD,STHD,SUHD
S-7693	348	GEAR KIT	SSHD,STDD,STHD,SUHD
S-6932	S-349	3 PC GEAR KIT	SLHD,SQHD,F
S-13914	KIT-363	SIDE GEAR KIT	R170 WITH "TE" SIDE GEAR
S-6957	383	GEAR KIT	SSHD,R170,STDD,STHD,SUHD
S-7679	MPS-488	GEAR KIT	G-742,2 1/2 TON
S-7698	KIT-533	GASKET MAKER KIT	SILICONE BLACK
S-3130	570	BOLT KIT	SQHD,SLHD,SQHP,SL,S,Q100
S-4616	947	BOLT KIT	F SERIES,D100/DHR,FDS1600,H140,HHR,JHR
S-5291	948	BOLT KIT	SSHD
S-5416	A-1199-P-1394	BREATHER	MULTIPLE APPLICATIONS
S-D489	1199-Z-1430	RETAINER	SHR
S-6958	1199-R-2176	PIN QTY PKG 100	SSHD,SLHD,SQHD,SQHP,SQ100
S-6959	1199-M-2457	PIN QTY PKG 100	SSHD
S-7667	1199-T-3842	GASKET MAKER	BLACK SILICONE
S-7199	A-1205-L-714	OIL SEAL	SLHD,SQHD
S-5173	A-1205-E-1227	OIL SEAL	SQHP,SQ100
S-7208	A-1205-N-1496	OIL SEAL	SW170,270,F
S-4710	A-1205-K-1779	OIL SEAL	SQHD,SSHD
S-A630	A-1205-W-1895	I/S TRIPLE LIP SEAL	SEE A-1205-P-2590
S-A720	A-1205-X-1896	T/S TRIPLE LIP SEAL	SEE A-1205-G-2425
S-5234	A-1205-Y-1897	P/S TRIPLE LIP SEAL	SL,SQ100,SQHP,RR
S-E014	A-1205-P-1914	OIL SEAL	SHR
S-E848	A-1205-A-1925	OIL SEAL	SSHD
S-9222	A-1205-D-1928	OIL SEAL	RS 13120,15120,H172, RS 16140,17140, 15210, RS17220,21230
S-A630	A-1205-F-2424	OIL SEAL	SEE A1205P2590
S-A720	A-1205-G-2425	OIL SEAL	NEW STYLE FOR A-1205-X-1896
S-B435	A-1205-N-2588	OIL SEAL	SL,SQ100,SQHP,RR
S-A630	A-1205-P-2590	OIL SEAL	NEW STYLE FOR A-1205-W-1895
S-A941	A-1205-Q-2591	OIL SEAL	RS-23-160/A,25-160/A,RT-40-160/A/P, 46-160/A/P,50-150,ETC
S-A942	A-1205-R-2592	OIL SEAL	RT-34-145/P,40-145/A/P,RT-44-145/P
S-14655	A1-1205-X-2728	OIL SEAL KIT	QD100,LD100,QRD100,QHP,LP100,QRP100

DIFFERENTIAL

LATEST ADDITIONS TO OUR CATALOG

EXCEPT WHERE SPECIFIED, ALL PARTS SUPPLIED ARE S&S/NEWSTAR. USE OF OTHER MANUFACTURERS' NAMES, PART NUMBERS, OR TRADEMARKS ARE FOR INFORMATIONAL AND IDENTIFICATION PURPOSES ONLY.

REPLACEMENT GEARS AND PARTS

APPLICATION: ARVIN MERITOR AXLES

NEW STAR NUMBER	REPLACEMENT FOR PART NUMBER	DESCRIPTION	APPLICATION - MODEL
S-2676	1227-N-898	NUT	SLHD,SQHD,SQHP,SQ100,F
S-6961	1227-Q-901	NUT	SQHP,SQ100,F
S-5483	1227-R-902	NUT	SQHP,SQ100
S-7342	1227-Z-936	NUT	SLHD,SQHD
S-7343	1227-A-937	NUT	SLHD,SQHD,SSHD,F
S-6962	1227-C-939	NUT	F-106
S-3929	1227-D-940	NUT	SLHD,SQHD,SSHD,F
S-7344	1227-J-946	NUT	SLHD,SQHD,SSHD
S-12036	1227-P-1056	NUT, SENSOR SWITCH	ALL WORLD AXLES W/ DIFF LOCK
S-16045	A-1228-L-1130	BEARING CONE	RR20-145, 22-145, RS21-145
S-3150	1229-D-992	WASHER QTY PKG 20	SSHD,R170
S-7345	1229-E-993	WASHER	SSHD,R170
S-A800	1229-L-1026	WASHER	STDD,SUDD,H170,RS-16-140,17-140,17-220
S-2304	1229-R-1032	WASHER QTY PKG 50	SQHD,SQHP,SQ100
S-7346	1229-T-1034	WASHER	SQHD,SQHP,SQ100
S-7347	1229-U-1061	WASHER QTY PKG 25	SLHD,SQHD,F
S-D478	1229-U-1113	SNAP RING	SSHD,SHR,R140,155
S-5531	1229-T-1606	WASHER QTY PKG 25	SSHD
S-2308	1229-G-1619	WASHER	SLHD,SQHD,F
S-7349	1229-J-1622	WASHER	SLHD,SQHD,F
S-7350	1229-N-1730	WASHER	SLHD,SQHD,SQHP,SQ100
S-A319	1229-T-1736	WASHER	RT-40-145,RD-40-145
S-A801	1229-H-2062	WASHER	SRDD,STDD,SUDD,SFDD4640,H170
S-10367	1229-L-2742	THRUST WASHER	180 AND 380
S-7351	1229-H-2764	WASHER	SL,SQ100,F,SQHP,F
S-8153	1229-M-2769	WASHER	SSHD
S-2308	1229-W-2857	WASHER	SEE 1229-G-1619
S-7347	1229-Q-2877	WASHER QTY PACK 25	SEE 1229-U-1061
S-C126	1229-Q-2929	WASHER	RD, RP-23-160, 23-164, 26-160
S-C127	1229-K-3001	WASHER	RS-23-160
S-C128	1229-L-3002	WASHER	RS-23-160
S-9783	1229-Y-3015	WASHER	RS-17-140,21-145,RT-34-145,40-145,44-145
S-5531	1229-Z-3094	WASHER	SEE 1229-T-1606
S-8017	1229-M-4069	WASHER	SQHP,LATE STYLE
S-A108	1229-P-4072	WASHER	SEE 1229D4788
S-A109	1229-K-4457	WASHER	RS-13-120,15-120
S-A972	1229-W-4521	WASHER	RT-46-160,52-160,RS-23-160,161,26-120
S-9783	1229-X-4522	WASHER	RS-21-145,17-140,RT-34-145,40-145,44-145
S-9782	1229-V-4624	WASHER	RS-21-145,RT-40140,40-145,44-145,34-145, RS-16-141,17-141,14-141
S-B930	1229-A-4785	WASHER	SEE 1229-D-4788
S-E080	1229-D-4788	WASHER	REPLACES 1229-A-4785 MODEL RT-40-145
S-7352	1244-Y-701	SPACER	SQHD
S-4095	1244-X-726	SPACER	SLHD,SQHD,F
S-5753	1250-E-473	MAGNETIC PLUG	MULTIPLE APPLICATIONS
S-4728	A-1805-B-80	OIL SEAL	SLHD,SQHD
S-F307	A-1805-F-162	OIL SEAL	R170, SSHD
S-4710	A-1805-D-212	OIL SEAL	SQHD,SSHD
S-F179	SG1825	PINION DRIVE GEAR	10 SPLINE- USE W/RR-RR SLHD, SQHD
S-9570	KIT-1912	BEARING & SEAL KIT	SQHP,SL,SQ100
S-9582	KIT-1913	BEARING & SEAL KIT	SLHD,SQHD
S-9705	KIT-1915	BEARING & SEAL KIT	LHR,QHR
S-9779	KIT-1916	BEARING & SEAL KIT	LHR,QHR
S-9562	KIT-1922	BEARING & SEAL KIT	SHR,R SERIES,PR SERIES
S-9561	KIT-1923	BEARING & SEAL KIT	SSHD
S-9557	KIT-1924	BEARING & SEAL KIT	R170,SW170

LATEST ADDITIONS TO OUR CATALOG

EXCEPT WHERE SPECIFIED, ALL PARTS SUPPLIED ARE S&S/NEWSTAR. USE OF OTHER MANUFACTURERS' NAMES, PART NUMBERS, OR TRADEMARKS ARE FOR INFORMATIONAL AND IDENTIFICATION PURPOSES ONLY.



REPLACEMENT GEARS AND PARTS

APPLICATION: ARVIN MERITOR AXLES

NEW STAR NUMBER	REPLACEMENT FOR PART NUMBER	DESCRIPTION	APPLICATION - MODEL
S-2013	MPS-1942	SHAFT KIT	SHF
S-9568	KIT-1976	BEARING & SEAL KIT	SQHD W/ 2"-39 SPLINE
S-6924	KIT-2117	KIT	SLHD,SQHD,F
S-E360	2203-A-469	SHIM .005	R170, SHR
S-F190	2203-G-2789	SHIM .005	RD, RP-17-145, 20-145
S-F191	2203-H-2790	SHIM .010	RD, RP-17-145, 20-145
S-5772	2203-R-3008	SHIM QTY PACK 20	SLHD,SQHD,F
S-5773	2203-S-3009	SHIM QTY PACK 20	SLHD,SQHD,F
S-A994	2203-B-6320	SHIM .010	SQHP,SQ100
S-8944	2203-R-6518	SHIM .003	SQHP, SQ100
S-8945	2203-S-6519	SHIM .005 QTY PACK 10	QD,LD,QRD100,QHP,LP,QP,QRP100
S-8946	2203-T-6520	SHIM .010 QTY PACK 10	QD,LD,QRD100,QHP,LP,QP,QRP100
S-E370	2203-Q-6803	SHIM .003	SSHD
S-E371	2203-R-6804	SHIM .005	SSHD
S-E372	2203-S-6805	SHIM .010	SSHD
S-E369	2203-K-7447	SHIM .005	SL/SQHD
S-E361	2203-C-8115	SHIM .003	SL/SQ100,LR/QR100,RT-40-145
S-E368	2203-E-8117	SHIM .010	SL/SQ100,LR/QR100,RT-40-145
S-C710	2203-K-9241	SHIM .003	RH-23-160,26-185,RT-34-145,40-145,46-160,52-180
S-C711	2203-L-9242	SHIM .005	RH-23-160,26-185,RT-34-145,40-145,46-160,52-180-
S-D827	2203-M-9243	SHIM .010	RD-RP-20-145,23-160
S-5759	2208-X-440	GASKET	SSHD,SQHD,F
S-11750	2214-C-1095	ADJUSTING NUT	140, 141 & 145
S-C506	2214-G-1125	ADJUSTER NUT	RP, RT-160
S-5802	2233-U-99	PINION GEAR	SSHD,R170
S-2223	2233-A-105	PINION GEAR	SLHD,SQHD,F
S-3641	2233-U-151	PINION GEAR	SLHD,SQHD,SQHP,SQ100
S-2344	2233-W-153	PINION GEAR	SHF,SQHP,F
S-8329	2233-C-159	PINION GEAR	R170
S-6966	2233-J-192	PINION GEAR	SQHP,SQ100,F
S-C393	2233-K-245	PINION GEAR	RD, RP-23-160-23-164, 26-160
S-C129	2233-M-1001	PINION GEAR	RS-23-180
S-A102	2233-J-1024	PINION GEAR	RS-21-230,21-145,17-140,RT-40-140, RT-34-145,RT-40-140,RT-40-145
S-A325	2233-Q-1031	PINION GEAR	RS-13-120,15-210
S-12032	2233-T-1112	PINION GEAR	380
S-A542	2234-E-187	SIDE GEAR	R100,R140,R200
S-2348	2234-K-271	SIDE GEAR	SSHD
S-2339	2234-X-310	SIDE GEAR	SLHD
S-7353	2234-M-325	SIDE GEAR	SLHD,SQHD,F
S-7354	2234-B-340	SIDE GEAR	SLHD,SQHD,F
S-2609	2234-F-344	SIDE GEAR	SSHD,R170
S-8330	2234-T-358	SIDE GEAR	R170
S-2051	2234-F-604	SIDE GEAR	SHF
S-13915	2234-E-629	SIDE GEAR	R170 "TE" MODEL
S-7355	2234-X-700	SIDE GEAR	SLHD,SQHD
S-2480	2234-X-778	SIDE GEAR	SQHP,SQ100,F
S-7356	2234-C-783	SIDE GEAR	SQHP,SQ100
S-2347	2234-M-793	SIDE GEAR	SHF
S-5239	2234-Q-797	SIDE GEAR	F106
S-2479	2234-N-846	SIDE GEAR	SQHP,SQ100
S-5238	2234-N-872	SIDE GEAR	F106
S-5863	2234-E-1019	SIDE GEAR	SQHP,SQ100
S-11542	2234-F-1046	SIDE GEAR	QRD, QRR100
S-C130	2234-C-1069	SIDE GEAR	RS-23-180
S-9786	2234-K-1077	SIDE GEAR	RS-21-230

DIFFERENTIAL



LATEST ADDITIONS TO OUR CATALOG

EXCEPT WHERE SPECIFIED, ALL PARTS SUPPLIED ARE S&S/NEWSTAR. USE OF OTHER MANUFACTURERS' NAMES, PART NUMBERS, OR TRADEMARKS ARE FOR INFORMATIONAL AND IDENTIFICATION PURPOSES ONLY.

REPLACEMENT GEARS AND PARTS

APPLICATION: ARVIN MERITOR AXLES

NEW STAR NUMBER	REPLACEMENT FOR PART NUMBER	DESCRIPTION	APPLICATION - MODEL
S-A326	2234-E-1097	SIDE GEAR	RS-13-120,15-210
S-9973	2234-R-1188	SIDE GEAR	RT-40-145,RD-20-145
S-C131	2234-T-1190	SIDE GEAR	RD, RP-23-160, 164, 26-160
S-9787	2234-U-1269	SIDE GEAR	RS-21-145,RT-40-140,RT-40-145
S-8538	2258-U-619	BRAKE SPRING, RETURN	161/2" "Q" BRAKES
S-5950	KIT-2266	CYLINDER KIT	SL, SQ100
S-6925	KIT-2269	COVER KIT	SQHP, SQ100
S-11762	KIT-2294	GEAR KIT	SQR100,P
S-5739	A-2297-E-811	FORK ASSEMBLY	SLHD,SQHD
S-11509	A1-2297-D-862	SHIFT FORK ASSEMBLY	SSHD
S-D929	2297-E-5335	SNAP RING	RT-34-145,40-140-145,44-145,RD-20-145
S-A131	KIT-2310	DIFF. KIT	RS-21-145,RT-40-140,40-145
S-9692	KIT-2316	INTER-AXLE DIFF. KIT	SQ100 LATE
S-B225	KIT-2317	BOLT KIT	RR-20-145,22-145,RS-21-145,17-140,RT-40145
S-C177	KIT-2318	GEAR KIT	RS-23-160
S-A105	KIT-2319	DIFF. KIT	RS-13-120, 15-120
S-10352	KIT-2329	DIFF KIT	RS-23-240
S-10031	KIT-2341	GEAR KIT LESS SPIDER	RS-23-160,161,25-160
S-A597	KIT-2347	INTER-DIFF KIT	RS-17-220
S-9950	KIT-2350	TWO SPEED REPAIR KIT W/HARDWARE	RS-21-230
S-9058	KIT-2393	BOLT KIT	NEW STYLE KIT SHR,R155
S-F263	KIT-2424	GEAR KIT	RD-23-160,164,26-160,RP-23-160,164,26-160
S-C492	KIT-2426	BOLT KIT	RD-RP-RS-23-160
S-F192	KIT-2429	SHIM KIT	RT-140,141,145
S-13320	MPS-2438	OIL PUMP GEAR KIT	SL,SQ100
S-C491	KIT-2455	TWO SPEED SHIFT KIT	RS-15-210
S-A223	KIT-2456	DIFF. KIT	RS-17-220
S-9891	KIT-2457	TWO SPEED REPAIR KIT	RS-21-230
S-11847	KIT-2458	SHIFT KIT	RS-23-240
S-A132	KIT-2482	HELICAL GEAR KIT	RT-34-145, 40-140, 40-145, 44-145
S-A104	KIT-2488	INTER-AXLE REPAIR KIT	RT-34-145, 40-140, 40-145, 44-145, RD-20-145
S-10345	KIT-2488-I39	INTER-AXLE REPAIR KIT	RD,RP-20-145
S-10030	KIT-2489	GEAR KIT LESS SPIDER	RD-23-160,23-164-26-160,RP-23-160,23-164
S-B436	KIT-2498	SHAFT KIT	SHF
S-11495	KIT-2522	GEAR KIT	RD,RP-22-145
S-C626	KIT-2623	UPGRADE KIT	RP, RT-40-145
S-A852	KIT-2636	HARDWARE KIT	RS-16-140, 17-140
S-A327	KIT-2637	HARDWARE KIT	RD-20-145, RT-40-145
S-15367	MPS-2637	UPDATE SHIFT KIT	SSHD
S-A853	KIT-2638	HARDWARE KIT	RT-46-160, 52-160, RS-23-160, 161,26-120
S-11496	KIT-2743	UPDATE KIT	RD,RP-20-145
S-A854	KIT-2759	SIDE GEAR KIT	RS-21-145, RT-40-140, 40-145
S-E641	KIT-2771	GEAR KIT	RD, RP-23-160, 26-160
S-6933	S-2824A-2	CAPSCREW	SQHD
S-13911	KIT-2825	SHIFT ASSEMBLY	RP, RT-160, 180, 380
S-10106	S-2826-2	BOLT. DIFF CASE	SQHD,SQHP SQ100
S-6927	MPS-2997	INTER DIFF. ASSEMBLY	SQHP, SQ100,F
S-13268	3107-P-16	COLLAR	RP,RR180 & 380
S-13882	3107-D-1018	COLLAR	RD-RP-20-145
S-E957	3107-M-1183	CLUTCH COLLAR	RS,RT140,141,145 SERIES
S-10373	3198-Y-1013	SHAFT PLANETARY PINION	RS-23-240
S-6968	3202-R-3268	AXLE SHAFT	SQHD
S-10183	3202-A-3459	AXLE SHAFT	SSHD
S-6970	3202-X-3508	AXLE SHAFT	SSHD-R170
S-6972	3202-L-6356	AXLE SHAFT	SQHP

LATEST ADDITIONS TO OUR CATALOG

EXCEPT WHERE SPECIFIED, ALL PARTS SUPPLIED ARE S&S/NEWSTAR. USE OF OTHER MANUFACTURERS' NAMES, PART NUMBERS, OR TRADEMARKS ARE FOR INFORMATIONAL AND IDENTIFICATION PURPOSES ONLY.



REPLACEMENT GEARS AND PARTS

APPLICATION: ARVIN MERITOR AXLES

NEWSTAR NUMBER	REPLACEMENT FOR PART NUMBER	DESCRIPTION	APPLICATION - MODEL
S-6973	3202-N-6358	AXLE SHAFT	SQHP
S-6974	3202-X-6472	AXLE SHAFT	SLHD
S-6975	3202-L-6564	AXLE SHAFT	SQHD
S-6977	3202-T-6728	AXLE SHAFT	SSHD
S-6978	3202-U-6729	AXLE SHAFT	SSHD
S-6980	3202-P-7816	AXLE SHAFT	F106
S-D845	3202-U-7977	AXLE SHAFT	SSHD, RS-23-157, R255,U340
S-D846	3202-V-7978	AXLE SHAFT	SSHD, RS-23-157, R255, U340
S-6981	3202-Q-8389	AXLE SHAFT	F106
S-12037	3202-H-8666	AXLE SHAFT	RS-23-180, 185, 186
S-11916	3202-Q-8805	AXLE SHAFT	23-160
S-11747	3202-B-8816	AXLE SHAFT	160, 161 & 164
S-A738	3202-J-8902	AXLE SHAFT	RS-17-220
S-A739	3202-L-8904	AXLE SHAFT	RS-17-220
S-9422	3202-W-8915	AXLE SHAFT	RS-21-230
S-12038	3202-Y-8917	AXLE SHAFT	RS-23-240
S-9422	3202-Q-8935	AXLE SHAFT	RS-21-230
S-D890	3202-E-9001	AXLE SHAFT	RS-13-120, 15-120, 15-125, 15-210
S-D889	3202-F-9002	AXLE SHAFT	RS-13-120, 15-120, 15-125, 15-210
S-D888	3202-F-9340	AXLE SHAFT	20-145, 21-145
S-D887	3202-G-9341	AXLE SHAFT	20-145, 21-145
S-D886	3202-H-9342	AXLE SHAFT	RD-RP-20-145, 22-145, RR-20-145, 22-145
S-11848	3202-S-9483	AXLE SHAFT	RS-20-145
S-A944	A-3226-X-180	CAGE ASSEMBLY	SSHD
S-7361	A-3226-M-585	RETAINER	SQHP, SQ100, F
S-6982	3226-E-629	RETAINER	SSHD
S-11794	A-3226-W-699	CAGE ASSEMBLY	SSHD
S-11540	A1-3226-W-699	CAGE & SHAFT KIT	SSHD
S-13167	A-3226-B-1016	CAGE ASSEMBLY	160E
S-13721	A1-3226-T-1112S	CAGE & SHAFT ASSY	RD-RP-20-145
S-9085	A-3235-W-751	CASE ASSEMBLY	SSHD EARLY STYLE
S-11408	A1-3235-N-1106	CASE ASSEMBLY	SSHD, RATIOS 4.89 THRU 7.40
S-11409	A4-3235-N-1106	CASE ASSEMBLY	SSHD, RATIOS 4.89 THRU 7.40
S-6983	A32-3235-N-1106	CASE ASSEMBLY	SSHD,R155 RATIOS 4.89 THRU 7.40
S-D479	A1-3235-Q-1109	CASE ASSEMBLY	SSHD RATIOS 3.90,4.11,4.33
S-6984	A39-3235-Q-1109	CASE ASSEMBLY	SSHD RATIOS 3.90,4.11,4.33
S-13615	A-3226-T-1112	CAGE ASSEMBLY	RD, RP-20-145
S-13678	A-3226-H-1126	CAGE ASSEMBLY	RP-24-160
S-A589	A17-3235-L-1156	CASE ASSEMBLY	SQHP, SQ100, QAR, QR100 (4.11-4.63)
S-8365	A26-3235-L-1156	CASE ASSEMBLY	SQHP, SQ100, QAR, QR100 (4.11-4.63)
S-6985	A1-3235-B-1172	CASE ASSEMBLY	SQHP, SQ100
S-2488	A4-3235-B-1172	CASE ASSEMBLY	SQHP, SQ100
S-8366	A19-3235-C-1173	CASE ASSEMBLY	SQHP-QAR, SQ100, QR100 (3.42-3.90)
S-8364	A28-3235-D-1174	CASE ASSEMBLY	SQHP, SQ100, QAR, QR100 (4.88-7.80)
S-2345	A-3235-B-1250	CASE ASSEMBLY	SSHD
S-6986	A1-3235-B-1250	CASE ASSEMBLY	SSHD
S-6986	A3-3235-B-1250	CASE ASSEMBLY	SSHD-SEE A1-3235-B-1250
S-7362	A1-3235-T-1528	CASE ASSEMBLY	SLHD, SQHD, F
S-7363	A2-3235-T-1528	CASE ASSEMBLY	SLHD, SQHD, F
S-11510	A-3235-X-1532	CASE ASSEMBLY	380
S-8360	A-3235-F-1800	CASE ASSEMBLY	SQHP W/ 39 SPLINE SPIDER
S-7856	A1-3235-F-1800	CASE ASSEMBLY	SL, SQ100, SQHP, SSHD
S-8230	A2-3235-F-1800	CASE ASSEMBLY	SL, SQ100, SQHP W/ 22 SPLINE
S-7857	A3-3235-F-1800	CASE ASSEMBLY	SL, SQ100, SQHP W/ 41 SPLINE
S-6988	A-3235-G-1801	CASE ASSEMBLY	SQHP,SQ100
S-11401	A2-3235-U-1841	CASE ASSEMBLY	USED W/ LOCKOUT- FOR RATIOS 4.30 THRU 7.17

DIFFERENTIAL



LATEST ADDITIONS TO OUR CATALOG

EXCEPT WHERE SPECIFIED, ALL PARTS SUPPLIED ARE S&S/NEWSTAR. USE OF OTHER MANUFACTURERS' NAMES, PART NUMBERS, OR TRADEMARKS ARE FOR INFORMATIONAL AND IDENTIFICATION PURPOSES ONLY.

REPLACEMENT GEARS AND PARTS

APPLICATION: ARVIN MERITOR AXLES

NEW STAR NUMBER	REPLACEMENT FOR PART NUMBER	DESCRIPTION	APPLICATION - MODEL
S-A945	A8-3235-U-1841	CASE ASSEMBLY	RP,RR,RS-21-145, (3.42-4.10)
S-11400	A2-3235-W-1843	CASE ASSEMBLY	USED W/ LOCKOUT- FOR RATIOS 3.42 THRU 4.11
S-A946	A8-3235-W-1843	CASE ASSEMBLY	RP,RR-20-145,RS-21-145, (4.30-7.17)
S-10369	A2-3235-S-1865	CASE ASSEMBLY	RS-23-240
S-C658	A4-3235-S-1865	CASE ASSEMBLY	RS-23-240
S-10351	A5-3235-S-1865	CASE ASSEMBLY	RS-23-240
S-B835	A3-3235-G-1905	DIFF CASE W/ PLANETARIES	RS-21-230
S-A133	A4-3235-G-1905	CASE ASSEMBLY	RS-21-230
S-B836	A3-3235-H-1906	DIFF CASE W/ PLANETARIES	RS-17-220
S-A134	A4-3235-H-1906	CASE ASSEMBLY	RS-17-220
S-9818	A-3235-W-2025	CASE ASSEMBLY	RT-40-145,RD-20-145
S-12030	A2-3235-C-2109	CASE ASSEMBLY	160,161 & 164 - FOR RATIOS 3.07 THRU 3.73
S-11826	A-3235-E-2111	CASE ASSEMBLY	FOR RATIOS 3.91 THRU 4.56 - 160,161 & 164
S-11827	A2-3235-E-2111	CASE ASSEMBLY	RD, RP, RS-23-160
S-C401	A2-3235-G-2113	MAIN CASE ASSEMBLY	RP-23-160
S-11795	A-3235-N-2380	CASE ASSEMBLY	RT-40-145,RD-20-145
S-C694	A3-3235-A-2393	CASE ASSEMBLY	160, 161 AND 164
S-C132	A-3261-L-350	CYLINDER	140, 141, 143 & 145
S-13910	A-3266-V-126	CAGE COVER	C100, 102, 103
S-7364	3266-H-970	COVER	SQHP,SQ100
S-C507	3266-C-1095	PINION COVER	160, 161 & 164
S-2342	3278-A-79	SPIDER	SSHD,R170
S-16009	3278-D-82	SPIDER	RS-16-140, 17-140
S-F227	3278-F-84	SPIDER	QDD-RDD, Q100, 145
S-7365	3278-H-86	SPIDER	SQHD,SQHP,SQ100
S-7366	3278-M-91	SPIDER	SLHD,SQHD,F
S-7678	3278-Z-104	SPIDER	F106,145
S-6989	3278-Y-129	SPIDER	SHF
S-6990	3278-J-244	SPIDER	SQHP,SQ100,F
S-2346	3278-Y-259	SPIDER	USE 3278V1088
S-C391	3278-N-300	SPIDER	RD,RP-23-160,164,26-160
S-7367	3278-S-305	SPIDER	SLHD,SQHD,SQ100,SQHP
S-C133	3278-W-335	SPIDER	RS-23-160
S-5864	3278-H-372	SPIDER	SQHP,SQ100
S-A057	3278-P-1004	SPIDER	RS-13-120,15-120
S-7946	3278-V-1088	SPIDER	SSHD-22 SPLINE
S-7858	3278-A-1093	SPIDER	SQHP,SL,SQ-100 W/41 SPLINE
S-2115	A-3280-Z-2444	SHAFT	SHF
S-7368	A-3280-V-2518	HOUSING	SLHD,SQHD,F
S-6991	3280-X-2520	CLUTCH COLLAR	SLHD,SQHD
S-7948	3280-F-5024	THRU SHAFT	T223
S-6992	3280-V-5040	FILTER	SQHP,F,SQ100,F
S-2485	3280-G-5519	CLUTCH COLLAR	SQHP,F,SL,SQ100,F
S-6993	A1-3280-S-5609	THRU SHAFT	SSHD
S-2487	3280-T-5688	THRU SHAFT	USE 3280L9528
S-7369	3280-L-6720	THRU SHAFT	SSHD
S-2039	3280-N-6748	THRU SHAFT	SHF
S-A849	3280-X-6758	END YOKE	SSHD 2"-39 SPLINE
S-6994	(A2-3280-X-6758) 3280-L-7604	CLUTCH	SSHD
S-10366	3280-G-8301	CASE HALF - RH	RS-17-220,19-220
S-10372	3280-H-8302	CASE HALF - RH	RS-21-230
S-10353	3280-J-8304	CASE HALF - RH	RS-23-240
S-E451	3280-R-8312	SUPPORT CASE, LH	RS-15-210
S-E450	3280-T-8314	CLUTCH PLATE	RS-15-210
S-B488	3280-W-8317	CASE HALF	RS-17-220

LATEST ADDITIONS TO OUR CATALOG

EXCEPT WHERE SPECIFIED, ALL PARTS SUPPLIED ARE S&S/NEWSTAR. USE OF OTHER MANUFACTURERS' NAMES, PART NUMBERS, OR TRADEMARKS ARE FOR INFORMATIONAL AND IDENTIFICATION PURPOSES ONLY.



REPLACEMENT GEARS AND PARTS

APPLICATION: ARVIN MERITOR AXLES

NEWSTAR NUMBER	REPLACEMENT FOR PART NUMBER	DESCRIPTION	APPLICATION - MODEL
S-B484	3280-Y-8319	CASE HALF	RS-21-230
S-B489	3280-A-8321	CLUTCH PLATE	RS-17-220
S-B485	3280-H-8328	CLUTCH PLATE	RS-21-230
S-A795	3280-V-8394	OIL FILTER	RH-26-185,23-186,RT-48-180,58-180,52-180,58-380,46-160P
S-13492	3280-Z-8398	SHIELD	RP-180
S-2487	3280-L-9528	OUTPUT SHAFT	SQHP,SQ100,F
S-5245	A-3296-T-150	SHIFT FORK	SQHP,SL,SQ100
S-C400	A-3296-T-1086	FORK ASSEMBLY	RD, RP-160, 164
S-C591	A-3296-A-1093	SHIFT FORK	RD-20-145,22-145,40-145
S-11846	3296-Z-1170	SHIFT FORK	140, 141 AND 145
S-12043	3296-N-1184	SHIFT FORK	180, 185 & 186 W/DIFF LOCK
S-2478	A1-3297-X-50	INPUT SHAFT	SQHP,F
S-11247	3297-S-97	OUTPUT SHAFT	RR-23-280
S-6995	A1-3297-F-110	INPUT SHAFT	SQ100,F
S-C135	3297-V-1010	THRU SHAFT	RT-160, 161, 164
S-E933	A-3297-V-1010	OUTPUT SHAFT KIT	RT-160,161,164
S-8103	A1-3297-Z-1014	INPUT SHAFT	SQ100,LATE STYLE
S-8104	A1-3297-A-1015	INPUT SHAFT	SQHP,LATE STYLE
S-A211	3297-E-1019	THRU SHAFT	RD,RP-17-145,RD,RP-20-145,RD-22-145
S-C392	A1-3297-X-1194	INPUT SHAFT	160, 161 & 164 W/PUMP
S-9788	A-3297-A-1197	INPUT SHAFT	RD-20-145 W/O OIL PUMP, RT-40-145 W/O OIL PUMP
S-13396	A1-3297-N-1288	INPUT SHAFT	FWD 180,185,186 AFTER 1993, REAR 380
S-A564	A-3297-T-1346	INPUT SHAFT	46 SPLINE RT-40-145 W/ PUMP
S-C440	A-3297-U-1347	INPUT SHAFT	RT-34-145,40-140,40-145,44-145
S-10529	A-3303-Q-1005	PUMP ASSEMBLY	T228 TRANSFER CASE
S-C134	A-3303-P-1030	PUMP ASSEMBLY	160,161 & 164
S-8228	MPS-3344	INTER DIFF. KIT	QD100,LD100,QRD100
S-C582	MPS-3344-145	INTER DIFF. KIT	RT-40-145
S-13545	MPS-3345-145	INTER DIFF. KIT	RT-40-145 WITH PUMP
S-8229	MPS-3345	INTER DIFF. KIT	QHP,LP100,QP100,QRP100
S-7840	A1-3889-L-272	GEAR SET	QD-R W/ OLD PINION 3890-P-354
S-2131	3891-N-950	PINION, PLANETARY	SFDD
S-6996	3891-L-974	SUN GEAR	_____
S-6997	3891-M-975	PLANETARY PINION	_____
S-7909	3892-P-1550	SUN GEAR	T223H
S-2126	3892-S-1553	BULL GEAR	SFDD
S-7947	3892-Y-1637	SUN GEAR	T223
S-6999	3892-X-1792	SUN GEAR	PR,PS-250,270
S-7000	3892-Z-1794	SUN GEAR	PR,PS-250,270
S-2040	3892-D-1798	DRIVE GEAR	SHF
S-7428	A-3892-D-1824	IDLER GEAR	SLHD,SQHD,F
S-2050	3892-F-1826	DRIVE GEAR	SHF
S-7429	3892-P-2044	DRIVE GEAR	SLHD,SQHD,F
S-7949	3892-Y-2443	DRIVE GEAR	T223
S-2486	3892-S-3945	DRIVE GEAR	SQHP,SQ100,F
S-7001	3892-P-3968	DRIVE GEAR	SQHP,SQ100,F
S-8242	3892-D-3982	PLANETARY GEAR	PR150
S-11466	3892-J-4014	DRIVE GEAR	180,185 & 186 SERIES, RR 380
S-7430	3892-S-4517	DRIVE GEAR	SLHD,SQHD,F
S-13405	3892-A-4733	PINION DRIVE GEAR	SQH-F
S-7431	3892-C-4735	DRIVE GEAR	SLHD,SQHD,F
S-7003	A-3892-C-4735	DRIVE GEAR W/ NUT	SLHD,SQHD,F
S-7004	3892-F-4738	DRIVE GEAR	SQHP,SQ100
S-C490	3892-H-4844	SUN GEAR	RS-15-210S
S-B487	3892-J-4846	SUN GEAR	RS-17-220

DIFFERENTIAL



LATEST ADDITIONS TO OUR CATALOG

EXCEPT WHERE SPECIFIED, ALL PARTS SUPPLIED ARE S&S/NEWSTAR. USE OF OTHER MANUFACTURERS' NAMES, PART NUMBERS, OR TRADEMARKS ARE FOR INFORMATIONAL AND IDENTIFICATION PURPOSES ONLY.

REPLACEMENT GEARS AND PARTS

APPLICATION: ARVIN MERITOR AXLES

NEW STAR NUMBER	REPLACEMENT FOR PART NUMBER	DESCRIPTION	APPLICATION - MODEL
S-B486	3892-K-4847	SUN GEAR	RS-21-230
S-10370	3892-L-4848	SUN GEAR	RS-23-240
S-10371	3892-R-4854	PLANETARY PINION	RS-23-240
S-8902	3892-N-4902	HELICAL PINION GEAR	RT-40-145, RD-20-145
S-C138	3892-U-4909	DRIVE GEAR	RD, RP23-160
S-8105	3892-M-4927	DRIVE GEAR	SQ100, SQHP, LATE STYLE
S-9974	3892-R-4932	DRIVE GEAR	RT-40-145, RP, RD-20-145
S-C137	3892-T-4934	DRIVE GEAR	160, 161 & 164
S-9582	KIT-4000	BEARING & SEAL KIT	SLHD, SQHD
S-9779	KIT-4005	BEARING & SEAL KIT	LHR, QHR
S-14082	KIT-4007	GEAR KIT	RD, RP-20-145
S-9705	KIT-4010	BEARING & SEAL KIT	LHR, QHR
S-9706	KIT-4025	BEARING & SEAL KIT	LHR, QHR
S-9570	KIT-4035	BEARING & SEAL KIT	SQHP, SL, SQ100
S-9568	KIT-4045	BEARING & SEAL KIT	QAR W/ 2"-39 SPLINE
S-9569	KIT-4065	BEARING & SEAL KIT	SLR, SQR
S-9561	KIT-4080	BEARING & SEAL KIT	SSHD
S-9562	KIT-4105	BEARING & SEAL KIT	SHR, R, PR
S-9557	KIT-4110	BEARING & SEAL KIT	R170, SW170
S-9839	KIT-4340	BEARING & SEAL KIT	RS-13-120, 15-120
S-C545	KIT-4390	BEARING & SEAL KIT	RS-21-145, RT-40-145, 44-145 AFTER 11/93
S-C546	KIT-4396	BEARING & SEAL KIT	RT-34-145, 40-145, 44-145 AFTER 11/93
S-A574	KIT-4400	BEARING & SEAL KIT	RS-21-145, RT-34-145, 40-145, 44-145,
S-C547	KIT-4405	BEARING & SEAL KIT	RT-40-145, 44-145 BEFORE 11/93
S-C548	KIT-4406	BEARING & SEAL KIT	RT-44-145 AFTER 11/93
S-C549	KIT-4415	BEARING & SEAL KIT	RS-23-160, 23-161, 26-160, 46-160, 52-160
S-F245	KIT-4420	BEARING & SEAL KIT	RT-46-160, 52-160
S-C550	KIT-4423	BEARING & SEAL KIT	RT-46-140, 52-160
S-C551	KIT-4426	BEARING & SEAL KIT	RS-23-160, 23-161, 26-160, RT-46-160, 52-160
S-C552	KIT-4428	BEARING & SEAL KIT	RS-23-160, 23-161, 26-160, 46-160, 52-160
S-C553	KIT-4435	BEARING & SEAL KIT	RS-23-180, RT-48-180, 52-180, 58-180
S-C407	KIT-4455	SENSOR KIT	RD-23-160
S-D943	KIT-4746	RETRO FIT KIT	160, 161 & 164 SERIES
S-10520	S-21020A-2	CASE BOLT	SSHD
S-10521	S-21028A-2	CASE BOLT	SSHD
S-9706	RA9R	BEARING & SEAL KIT	LHR, QHR W/ 1 3/16" PINION
S-9705	RA9RB	BEARING & SEAL KIT	LHR, QHR W/ 1 3/8" PINION
S-9779	RA9RC	BEARING & SEAL KIT	LHR, QHR W/ 1 3/8" PINION -RATIOS 4.63 & BELOW
S-9557	RA50	BEARING & SEAL KIT	R170, SW170
S-9561	RA172FB	BEARING & SEAL KIT	SSHD W/ INVOLUTE
S-9562	RA172R	BEARING & SEAL KIT	SHR, R SERIES
S-9568	RA194RA	BEARING & SEAL KIT	SQAR, W/ 39 SPLINES
S-9569	RA194RB	BEARING & SEAL KIT	SLR, SQR
S-9570	RA194F	BEARING & SEAL KIT	SQHP, SL, SQ100
S-9578	RA217F	BEARING & SEAL KIT	RD, RP-17-145, 20-145, 22-145, 34-145, 40-145, 44-145
S-A574	RA217R	BEARING & SEAL KIT	RR-17-145, 20-145, 22-145, RS-21-145, RT-34-145, 40-145, 44-145
S-9839	RA218	BEARING & SEAL KIT	RS-13-120, 15-120
S-A575	RA224	BEARING & SEAL KIT	RR-20-145, RS-21-145, RT-40-145
S-9582	RA900F	BEARING & SEAL KIT	SLHD, SQHD
S-C489	SQ100FSKL	REPAIR KIT	SQ100

LATEST ADDITIONS TO OUR CATALOG

EXCEPT WHERE SPECIFIED, ALL PARTS SUPPLIED ARE S&S/NEWSTAR. USE OF OTHER MANUFACTURERS' NAMES, PART NUMBERS, OR TRADEMARKS ARE FOR INFORMATIONAL AND IDENTIFICATION PURPOSES ONLY.



REPLACEMENT CONVENIENCE KITS

APPLICATION: ARVIN MERITOR WORLD AXLES



NEW STAR
NUMBER

REPLACEMENT FOR
PART NUMBER

S-13545 MPS-3345-145

APPLICATION: RT-40-145 WITH PUMP

CONSISTS OF ONE EACH:

NEW STAR NUMBER	REPLACEMENT FOR PART NUMBER	DESCRIPTION
S-9818	A-3235-W-2025	CASE ASSEMBLY
S-A564	A-3297-T-1346	INPUT SHAFT
S-9973	2234-R-1188	SIDE GEAR
S-D929	2297-F-5335	SNAP RING
S-A942	A-1205-R-2592	OIL SEAL
S-9974	3892-R-4932	DRIVE GEAR
S-E080	1229-D-4788	WASHER
S-A973	40-X-1233	NUT
S-C710	2203-K-9241	SHIM
S-C711	2203-L-9242	SHIM
S-D827	2203-M-9243	SHIM



NEW STAR
NUMBER

REPLACEMENT FOR
PART NUMBER

S-10345 KIT 2488-39I

APPLICATION: RT-34-145,40-140,40-145,44-145,RD-20-145

CONSISTS OF ONE EACH:

NEW STAR NUMBER	REPLACEMENT FOR PART NUMBER	DESCRIPTION
S-9818	A-3235-W-2025	CASE ASSEMBLY
S-A793	A1-3297-Q-1161	INPUT SHAFT-39 SPLINE
S-9973	2234-R-1188	SIDE GEAR
S-9974	3892-R-4932	DRIVE GEAR
S-8017	1229-M-4069	WASHER
S-E080	1229-D-4788	WASHER
S-D929	2297-E-5335	SNAP RING
S-A215	40-X-1237	NUT
S-A630	A-1205-P-2590	OIL SEAL



NEW STAR
NUMBER

REPLACEMENT FOR
PART NUMBER

S-A104 KIT 2488

APPLICATION: RT-34-145,40-140,40-145,44-145,RD-20-145

CONSISTS OF ONE EACH:

NEW STAR NUMBER	REPLACEMENT FOR PART NUMBER	DESCRIPTION
S-9818	A-3235-W-2025	CASE ASSEMBLY
S-9973	2234-R-1188	SIDE GEAR
S-9974	3892-R-4932	DRIVE GEAR
S-E080	1229-D-4788	WASHER
S-D929	2297-E-5335	SNAP RING

DIFFERENTIAL



REPLACEMENT CONVENIENCE KITS

APPLICATION: ARVIN MERITOR WORLD AXLES



NEW★STAR
NUMBER

REPLACEMENT FOR
PART NUMBER

S-A534

RT-40-145FSKE

APPLICATION: AXLE MODEL RT-40-145

CONSISTS OF ONE EACH:

NEW★STAR NUMBER	REPLACEMENT FOR PART NUMBER	DESCRIPTION
S-9818	A-3235-W-2025	CASE ASSEMBLY
S-9788	A-3297-A-1197	INPUT SHAFT - 39 SPLINE
S-9973	2234-R-1188	SIDE GEAR
S-8902	3892-N-4902	DRIVE GEAR
S-9974	3892-R-4932	DRIVE GEAR
S-8017	1229-M-4069	WASHER



NEW★STAR
NUMBER

REPLACEMENT FOR
PART NUMBER

S-C582

MPS-3344-145
RT-40-145FSKL

APPLICATION: AXLE MODEL RT-40-145

CONSISTS OF ONE EACH:

NEW★STAR NUMBER	REPLACEMENT FOR PART NUMBER	DESCRIPTION
S-9818	A-3235-W-2025	CASE ASSEMBLY
S-C440	A-3297-U-1347	INPUT SHAFT-39 SPLINE
S-9973	2234-R-1188	SIDE GEAR
S-9974	3892-R-4932	DRIVE GEAR
S-E080	1229-D-4788	WASHER
S-A973	40-X-1233	NUT
S-C710	2203-K-9241	SHIM
S-C711	2203-L-9242	SHIM
S-D827	2203-M-9243	SHIM

REPLACEMENT RING GEAR AND PINION SETS

APPLICATION: VARIOUS CLARK AXLES



NEW★STAR NUMBER	REPLACEMENT FOR PART NUMBER	DESCRIPTION	APPLICATION - MODEL
S-6318	122443	GEAR SET 6.83 RH	1230
S-6310	815202	GEAR SET 6.33 LH	1390
S-2328	815328	GEAR SET 3.27 RH	1640, BD-70-90
S-6314	815357	GEAR SET 4.10 RH	1640, BD-50-70-90-91
S-6318	815931	GEAR SET 6.83 RH	1230

REPLACEMENT GEAR AND MISC. PARTS

APPLICATION: VARIOUS CLARK AXLES

NEW★STAR NUMBER	REPLACEMENT FOR PART NUMBER	DESCRIPTION	APPLICATION - MODEL
S-16552	101244	PINION WASHER	1530
S-6182	106232	SUN GEAR	1640, BD90
S-6183	106356	GEAR	BD-70
S-6185	110527	PINION GEAR	1850
S-6186	110528	SIDE GEAR	1850
S-6196	117044	PINION	1640, BD-90
S-2458	117947	GEAR	BD-70-90
S-6200	117960	GEAR	BD-70-90
S-8880	118474	WASHER	1530
S-6201	118478	WASHER	1640, BD-70-90
S-2462	124084	SHAFT	BD-70-90
S-2705	124086	SHAFT	BD-70-90
S-6215	124284	SHAFT	BD-70-90
S-6226	127814	SPIDER CROSS	BD-90-91
S-6227	127817	PINION WASHER	1640, BD-70-90
S-6316	815746	PINION GEAR KIT	1640, BD-90
S-6320	816044	SIDE GEAR KIT	BD90, 91
S-6323	816207	SIDE GEAR KIT	1850
S-6316	2107055	PINION GEAR KIT	1640, BD-90

DIFFERENTIAL



LATEST ADDITIONS TO OUR CATALOG

EXCEPT WHERE SPECIFIED, ALL PARTS SUPPLIED ARE S&S/NEWSTAR. USE OF OTHER MANUFACTURERS' NAMES, PART NUMBERS, OR TRADEMARKS ARE FOR INFORMATIONAL AND IDENTIFICATION PURPOSES ONLY.

RING GEAR AND PINION SETS

SUITABLE FOR DANA® AXLES



NEW STAR NUMBER	REPLACEMENT FOR PART NUMBER	RATIO	DESCRIPTION	APPLICATION MODEL
S-A396	24638-5X	3.54	GENUINE GEAR SET REV. CUT	44
S-E703	24807-5X	4.10	GEAR SET	60
S-8594	24813-5X	3.54	GEAR SET	60
S-A393	29244-5X	3.70	GENUINE GEAR SET	30
S-8544	706033-1X	3.54	RING GEAR & PINION W/ INSTALLATION KIT	60
S-E704	706033-3X	4.10	RING GEAR & PINION W/ INSTALLATION KIT	60

REPLACEMENT COMPONENT PARTS

APPLICATION: CHRYSLER AXLES

NEW STAR NUMBER	REPLACEMENT FOR PART NUMBER	DESCRIPTION	APPLICATION - MODEL
S-9796	4137429	9.25"	AXLE SHAFT
S-9493	4746879	7.25" 10 BOLT-25 SPLINE	GEAR KIT
S-9530	RA303	8.25", 8.375"	BEARING & SEAL KIT
S-9531	RA304	9.25"	BEARING & SEAL KIT

INSTALLATION KIT

TO REPLACE DANA® LIGHT DUTY
CONSISTING OF ALL NEEDED BEARINGS, SHIMS, SLEEVES, BOLTS, ETC.



NEW★STAR NUMBER	REPLACEMENT FOR PART NUMBER	DESCRIPTION	MODEL NUMBER
S-8682	RA60	INSTALLATION KIT	60
S-8683	RA70	INSTALLATION KIT	70
S-9831	43651-1 AXLE SHAFT	FORD MODEL F350 TRUCKS	80

BEARING AND SEAL KIT

SUITABLE FOR DANA® AXLES

NEW★STAR NUMBER	REPLACEMENT FOR PART NUMBER	MODEL NUMBER
S-9546	RA331	60
S-9547	RA332	70
S-9549	RA334	30AF
S-D579	RA334TJ	30 1997 & UP
S-D578	RA336	50IFS 1980 & UP
S-C104	RA337	80

GEARS AND MISCELLANEOUS PARTS

SUITABLE FOR DANA® (FORMERLY HILLARD) AXLES

NEW STAR NUMBER	REPLACEMENT FOR		DESCRIPTION	APPLICATION
	DANA® NUMBER	INTERNATIONAL TRUCK NUMBER		
S-9757	GGA-GH-100	597168C1	CLUTCH PLATE	G155T,175T
S-A344	GGA-GU-101	597156C1	IDLER GEAR	G175T,M190T
S-13453	HN162	1696474C1	NUT	N400
S-7120	MJA-GS-100	597171C1	SUN GEAR	190T,220T
		EOHZ4055B		
S-9173	MJA-GH-102	597173C1	RETAINER	M190T,210T,220T,230T
S-A343	MJA-HH-102	597148C1	OIL SEAL	G155T,175T
S-A830	MJA-KD-103	597105C91	GEAR KIT	M230T,G175S,M200S,220S,T, M190T,G175T,M210T
S-9131	MJA GA-103X (MJA-KG-120X)	597140C91	GEAR SET 5.57	M190T, M220T, M230T
S-7119	MJA-GU-100	597155C1	PLANETARY PINION	190T,220T
		EOHZ4040B		
S-12106	057-KY-101X	1697352C91	BOLT KIT	RA474
S-8753	400-GD-100	1665300C1	SIDE GEAR	N340,400,X380
S-8752	401-KK-100-X	1665326C1	INPUT SHAFT	N340,400,X380
S-A364	401-QK-100	1665327C91	CASE KIT	N400 (3.06 THRU 4.44)
S-F072	401-DP-101	---	SPIDER CROSS	N400
S-A345	401-GS-101	1665309C91	GEAR ASSEMBLY	N400
S-D752	401-HS-101	1665315C1	WASHER	N400
S-E248	401-HS-115	1665324C1	SPACER	N400
S-A580	401-KD-100X	1665325C91	CASE ASSEMBLY	N400
S-9275	401-KK-101	1665379C91	OUTPUT SHAFT	N340,X380,N400
S-A365	401-KQ-101X	1665328C91	CASE KIT	N400 (4.56 THRU 6.04)
S-B246	401-KY-101	1696994C1	BOLT KIT	N175,190,210,J190S,210S, G175T,190T,220T,J340S,380S,400S
S-8757	401-SH-101	1665332C1	SHIFT COLLAR	N340,400,X380
S-8756	401-DS-102X	1665307C91	INTER-DIFF. ASSY.	N340,X380,N400
S-A712	401-GS-102	1665380C1	DRIVE GEAR	N340,400
S-C005	401-KK-102X	1692964C91	INPUT SHAFT KIT	N340,400
S-D594	401-SS-103	1665334C1	SHAFT	N340,400
S-9275	401-SS-104	1665379C91	OUTPUT SHAFT	N340,X380,N400
S-9720	HN130	1696471C1	PINION NUT	G175S,G190S,G155T, G175T,M200S,M220S, M190T,M210T,M220T,M230T N340,N400,S122,S135, S150
S-9893	RA223F	1665333C91	BEARING & SEAL KIT	N400
S-A469	RA223R	1665329C91	BEARING & SEAL KIT	N400 REAR

LATEST ADDITIONS TO OUR CATALOG

EXCEPT WHERE SPECIFIED, ALL PARTS SUPPLIED ARE S&S/NEWSTAR. USE OF OTHER MANUFACTURERS' NAMES, PART NUMBERS, OR TRADEMARKS ARE FOR INFORMATIONAL AND IDENTIFICATION PURPOSES ONLY.



RING GEAR AND PINION SETS

SUITABLE FOR VARIOUS DANA® (FORMERLY EATON) AXLES

NEWSTAR NUMBER	REPLACEMENT FOR PART NUMBER	DESCRIPTION	APPLICATION MODEL
S-13447	27927	GEAR SET 5.83	1350
S-7377	35055	GEAR SET 6.17	RA 30
S-7378	35056	GEAR SET 7.17	RA 30
S-6356	35057	GEAR SET 6.50	RA 39
S-8251	95529	GEAR SET 4.62	30DP
S-6411	95536	GEAR SET 3.70	34, 38DS
S-6412	95537	GEAR SET 4.11	34, 38DS
S-6413	95538	GEAR SET 4.33	34,38DS
S-7488	95539	GEAR SET 4.56	34,38DS
S-7489	95540	GEAR SET 4.88	34,38DS
S-7950	95541	GEAR SET 5.29	34,38DS
S-8243	95542	GEAR SET 5.57	34,38DS
S-7916	95547	GEAR SET 3.70	34,38,42DT,DP,D3
SA454	95548	GEAR SET 4.11	34,38,42DT,DP,D3
SA456	95550	GEAR SET 4.56	34,38,42DT,DP,D3
SA457	95551	GEAR SET 4.88	34,38,42DT,DP,D3
SA458	95552	GEAR SET 5.29	34,38,42DT,DP,D3
S-13425	95554	GEAR SET 6.14	34,38DP,DT
S-6415	95558	GEAR SET 4.11	DS340,380,400
S-8244	95559	GEAR SET 4.33	DS340,380,400
S-7918	95561	GEAR SET 4.88	DS340,380,400
S-8507	95567	GEAR SET 4.11	DT,DP340,380,400,50DT,DP
SA975	95579	GEAR SET 4.56	44DS,DS480
S-8095	95581	GEAR SET 5.43	44DS,DSM,DS480P
S-9949	95585	GEAR SET 4.33	44DT,DP,DT480P,DP580,650P,SP580,650,TP580,650
S-9880	95586	GEAR SET 4.56	44DT,DP,DT480P,DP580,650P,SP580,650,TP580,650
S-15277	95588	GEAR SET 5.43	44DT,DP,650,TP580,650
S-6419	96619	GEAR SET 3.70	17100-1,18100-1,34,38RS
S-6420	96620	GEAR SET 4.11	17100-1,18100-1,34,38RS
S-6421	96621	GEAR SET 4.33	17100-1,18100-1,34,38RS
S-6422	96622	GEAR SET 4.56	17100-1,18100-1,34,38RS
S-8216	96623	GEAR SET 4.88	17100-1,18100-1,34,38RS
S-7490	96625	GEAR SET 5.57	17100-1,18100-1,34,38RS
S-D690	96628	GEAR SET 6.50	17120-1,18120-1
S-6424	96629	GEAR SET 7.17	17120-1,18120-1
S-F214	96640	GEAR SET 7.60	17120-3
S-8245	96641	GEAR SET 3.70	RS340,380,400
S-8246	96642	GEAR SET 4.11	RS340,380,400
S-7920	96644	GEAR SET 4.56	RS340,380,400
S-10512	96797	GEAR SET 4.56	16243-4,16344
S-6427	96798	GEAR SET 4.88	16243-4,16344
S-6428	96799	GEAR SET 5.57	16243-4,16344
S-6429	96833	GEAR SET 3.70	17200-1,17320-1,18220-1,18320-1, 34,38,42RT,RP,R3RT,RP340,380,400,50RT,RP
S-7690	96834	GEAR SET 4.11	17200-1,17320-1,18220-1,18320-1, 34,38,42RT,RP,R3RT,RP340,380,400,50RT,RP
S-7955	96835	GEAR SET 4.33	17200-1,17320-1,18220-1,18320-1, 34,38,42RT,RP,R3RT,RP340,380,400,50RT,RP
S-7491	96836	GEAR SET 4.56	17200-1,17320-1,18220-1,18320-1, 34,38,42RT,RP,R3RT,RP340,380,400,50RT,RP
S-6430	96837	GEAR SET 4.88	17200-1,17320-1,18220-1,18320-1, 34,38,42RT,RP,R3RT,RP340,380,400,50RT,RP
S-7492	96838	GEAR SET 5.29	17200-1,17320-1,18220-1,18320-1, 34,38,42RT,RP,R3RT,RP340,380,400,50RT,RP
S-7722	96839	GEAR SET 5.57	17200-1,17320-1,18220-1,18320-1, 34,38,42RT,RP,R3RT,RP340,380,400,50RT,RP
S-6431	96840	GEAR SET 5.57	17220-1,17320-1,18220-1,18320-1,34,38,42RT,RP,R3
S-7756	96841	GEAR SET 6.14	17220-1, 17320-1, 18220-1, 18320-1, 34, 38, 42RT, RP
S-E185	96873	GEAR SET 4.11	19,120,121
S-7956	98103	GEAR SET 4.88	19420-123420-1,26420-1,44RS,RSM,RS480,23121,26121
S-8248	98104	GEAR SET 5.43	19420-123420-1,26420-1,44RS,RSM,RS480,23121,26121

DIFFERENTIAL



LATEST ADDITIONS TO OUR CATALOG

EXCEPT WHERE SPECIFIED, ALL PARTS SUPPLIED ARE S&S/NEWSTAR. USE OF OTHER MANUFACTURERS' NAMES, PART NUMBERS, OR TRADEMARKS ARE FOR INFORMATIONAL AND IDENTIFICATION PURPOSES ONLY.

RING GEAR AND PINION SETS

SUITABLE FOR VARIOUS DANA® (FORMERLY EATON) AXLES

NEW STAR NUMBER	REPLACEMENT FOR PART NUMBER	DESCRIPTION	APPLICATION MODEL
S-A110 S-6434	98105 98107	GEAR SET 6.17 GEAR SET 3.70	19420-123420-1,26420-1,44RS,RSM,RS480,23121,26121 19220-1,19320-1,20220-1,20320-1,23221,23321, 26221,26321,44RT,RP,RT,RP480,580,650
S-9850	98108	GEAR SET 4.11	19220-1,19320-1,20220-1,20320-1,23221,23321, 26221,26321,44RT,RP,RT,RP480,580,650
S-9851	98109	GEAR SET 4.33	19220-1,19320-1,20220-1,20320-1,23221,23321, 26221,26321,44RT,RP,RT,RP480,580,650
S-9852	98110	GEAR SET 4.56	19220-1,19320-1,20220-1,20320-1,23221,23321, 26221,26321,44RT,RP,RT,RP480,580,650
S-9877	98111	GEAR SET 4.88	19220-1,19320-1,20220-1,20320-1,23221,23321, 26221,26321,44RT,RP,RT,RP480,580,650
S-6435	98112	GEAR SET 5.43	19220-1,19320-1,20220-1,20320-1,23221,23321, 26221,26321,44RT,RP,RT,RP480,580,650
S-6436	98113	GEAR SET 6.17	19220-1,19320-1,20220-1,20320-1,23221,23321, 26221,26321,44RT,RP,RT,RP480,580,650
S-7957	98114	GEAR SET 6.67	19220-1,19320-1,20220-1,20320-1,23221,23321, 26221,26321,44RT,RP,RT,RP480,580,650
S-7922	98116	GEAR SET 4.33	RT,RP340,380,400,50RT,RP
S-6437	98120	GEAR SET 5.57	RT,RP340,380,400,50RT,RP
S-8347	98121	GEAR SET 6.14	RT,RP340,380,400,50RT,RP
S-6442	98757	GEAR SET 6.33	15201
S-16540	99427	GEAR SET 5.43	23120-7
S-16546	99490	GEAR SET 7.17	16145
S-16545	99497	GEAR SET 3.70	19100-1
S-D739	99507	GEAR SET 6.50	17120-1,18120-1,38RS
S-D740	99508	GEAR SET 7.17	17120-1,18120-1,38RS
S-6449	99511	GEAR SET 3.09	2590
S-6450	99521	GEAR SET 4.11	17100-1,18100-1,34RS
S-16542	99534	GEAR SET 6.50	17120-3
S-8096	99666	GEAR SET 6.14	17200-1,18200-1,34/38/42RT,RP,R3
S-7959	104524	GEAR SET 5.29	DS440P,460P
S-8998	104536	GEAR SET 5.29	RS440P,460
S-16543	106633	GEAR SET 6.50	34MF
S-16547	107557	GEAR SET 3.90	22220-1
S-13925	107558	GEAR SET 4.11	22-220-1
S-7961	107561	GEAR SET 4.88	22220-1,22320-1
S-7962	107563	GEAR SET 5.57	22220-1,22320-1
S-8249	107565	GEAR SET 6.50	22220-1,22620-1
S-13885	107622	GEAR SET 6.17	23220-7 REV CUT PINION
S-8388	111174	GEAR SET 3.55	SEE 127266 1ST GEN
S-8389	111175	GEAR SET 3.70	SEE 127267 1ST GEN
S-A986	111176	GEAR SET 3.90	SEE 127268 1ST GEN
S-A987	111177	GEAR SET 4.11	SEE 127269 1ST GEN
S-A988	111178	GEAR SET 4.33	SEE 127270 1ST GEN
S-9147	111188	GEAR SET 4.11	SEE 217986 1ST GEN
S-9148	111189	GEAR SET 4.33	SEE 217987 1ST GEN
S-9393	111502	GEAR SET 3.70	SEE 217998 1ST GEN
S-9429	111503	GEAR SET 3.90	RS381 1ST GEN
S-A991	111504	GEAR SET 4.11	SEE 218000 1ST GEN
S-A209	111505	GEAR SET 4.33	SEE 218001 1ST GEN
S-11485	111515	GEAR SET 4.11	SEE 219012
S-D469	111516	GEAR SET 4.33	SEE 219013
S-16544	119352	GEAR SET 5.43	DS480P
S-13030	113451	GEAR SET 6.29	15201
S-B244	121545	GEAR SET 4.56	19050T
S-A111	121546	GEAR SET 4.88	19050T
S-11341	121547	GEAR SET 5.29	19050T
S-A112	121548	GEAR SET 5.57	19050T
S-A113	121549	GEAR SET 6.14	19050T
S-A114	121550	GEAR SET 6.57	19050T
S-A115	121551	GEAR SET 7.17	19050T

LATEST ADDITIONS TO OUR CATALOG

EXCEPT WHERE SPECIFIED, ALL PARTS SUPPLIED ARE S&S/NEWSTAR. USE OF OTHER MANUFACTURERS' NAMES, PART NUMBERS, OR TRADEMARKS ARE FOR INFORMATIONAL AND IDENTIFICATION PURPOSES ONLY.



RING GEAR AND PINION SETS

SUITABLE FOR VARIOUS DANA® (FORMERLY EATON) AXLES

NEW STAR NUMBER	REPLACEMENT FOR PART NUMBER	DESCRIPTION	APPLICATION MODEL	
S-B253	121761	GEAR SET 5.57	19050S	
S-B493	121887	GEAR SET 3.70	RS461	
S-D804	121888	GEAR SET 4.11	RS461	
S-D805	121889	GEAR SET 4.33	RS461	
S-D806	121890	GEAR SET 4.56	RS461	
S-D807	121891	GEAR SET 4.88	RS461	
S-13923	121892	GEAR SET 5.43	RS461	
S-13174	121893	GEAR SET 6.17	RS461,521,601,651	
S-B494	122334	GEAR SET 3.70	DS461P	
S-A624	122335	GEAR SET 4.11	DS461P,521P,581P	
S-B627	122338	GEAR SET 4.88	DS461P	
S-A460	122388	GEAR SET 4.11	DT461	
S-A461	122389	GEAR SET 4.33	DT461	
S-A476	122390	GEAR SET 4.56	DT461	
S-A874	122391	GEAR SET 4.88	DT461	
S-A462	122395	GEAR SET 4.11	RT461,521,601,651	
S-A463	122396	GEAR SET 4.33	RT461,521,601,651	
S-A464	122397	GEAR SET 4.56	RT461,521,601,651	
S-A875	122398	GEAR SET 4.88	RT461,521,601,651	
S-13179	122399	GEAR SET 5.43	RS461,521,601,651	
S-13177	122400	GEAR SET 6.17	RS461,521,601,651	
S-B629	123333	GEAR SET 3.90	DS461P	
S-B628	123334	GEAR SET 3.90	RS461P	
S-8383	127253	GEAR SET 3.55	SEE 217997	2ND GEN
S-9393	127254	GEAR SET 3.70	SEE 217998	2ND GEN
S-A990	127255	GEAR SET 3.90	SEE 217999	2ND GEN
S-A991	127256	GEAR SET 4.11	SEE 218000	2ND GEN
S-A209	127257	GEAR SET 4.33	SEE 218001	2ND GEN
S-A873	127258	GEAR SET 4.56	SEE 218002	2ND GEN
S-C436	127259	GEAR SET 4.88	SEE 218003	2ND GEN
S-9637	127260	GEAR SET 5.29	SEE 218004	2ND GEN
S-9228	127262	GEAR SET 6.14	RS341,381,401,402,451	2ND GEN
S-9876	127265	GEAR SET 3.36	SEE 217980	2ND GEN
S-8388	127266	GEAR SET 3.55	DS341,381,402,451	2ND GEN
S-8389	127267	GEAR SET 3.70	DS341,381,405,451	2ND GEN
S-A986	127268	GEAR SET 3.90	SEE 217983	2ND GEN
S-A987	127269	GEAR SET 4.11	SEE 217984	2ND GEN
S-A988	127270	GEAR SET 4.33	SEE 217985	2ND GEN
S-A690	127271	GEAR SET 4.56	SEE 217986	2ND GEN
S-9393	127273	GEAR SET 5.29	SEE 217998	2ND GEN
S-E297	211466	GEAR SET 3.36	DS404, 405, 454	
S-A976	211467	GEAR SET 3.55	DS404, 405, 454	
S-A977	211468	GEAR SET 3.70	DS404, 405, 454	
S-A978	211469	GEAR SET 3.90	DS404, 405, 454	
S-A979	211470	GEAR SET 4.11	DS404, 405, 454	
S-C175	211471	GEAR SET 4.33	DS404, 405, 454	
S-E234	211472	GEAR SET 4.63	DS404, 405, 454	
S-F370	211474	GEAR SET 5.29	DS404, 405, 454	
S-10127	211482	GEAR SET 3.36	RS404, 405, 454	
S-A980	211483	GEAR SET 3.55	RS404, 405, 454	
S-A981	211484	GEAR SET 3.70	RS404, 405, 454	
S-A982	211485	GEAR SET 3.90	RS404, 405, 454	
S-A983	211486	GEAR SET 4.11	RS404, 405, 454	
S-D426	211487	GEAR SET 4.33	RS404, 405, 454	
S-E235	211488	GEAR SET 4.63	RS404, 405, 454	
S-9876	217980	GEAR SET 3.36	DS402	3RD GEN
S-A986	217983	GEAR SET 3.90	DS402	3RD GEN
S-A987	217984	GEAR SET 4.11	DS402	3RD GEN
S-A988	217985	GEAR SET 4.33	DS402	3RD GEN
S-A690	217986	GEAR SET 4.56	DS402	3RD GEN
S-F002	217987	GEAR SET 4.88	DS402	3RD GEN

DIFFERENTIAL



LATEST ADDITIONS TO OUR CATALOG

EXCEPT WHERE SPECIFIED, ALL PARTS SUPPLIED ARE S&S/NEWSTAR. USE OF OTHER MANUFACTURERS' NAMES, PART NUMBERS, OR TRADEMARKS ARE FOR INFORMATIONAL AND IDENTIFICATION PURPOSES ONLY.

RING GEAR AND PINION SETS

SUITABLE FOR VARIOUS DANA® (FORMERLY EATON) AXLES

NEW STAR NUMBER	REPLACEMENT FOR PART NUMBER	DESCRIPTION	APPLICATION MODEL	
S-A089	217988	GEAR SET 5.29	DS402	3RD GEN
S-9843	217996	GEAR SET 3.36	RS402 LATE EXTENDED SPLINE	3RD GEN
S-A989	217997	GEAR SET 3.55	RS402 LATE EXTENDED SPLINE	3RD GEN
S-9393	217998	GEAR SET 3.70	RS402 LATE EXTENDED SPLINE	3RD GEN
S-A990	217999	GEAR SET 3.90	RS402 LATE EXTENDED SPLINE	3RD GEN
S-A991	218000	GEAR SET 4.11	RS402 LATE EXTENDED SPLINE	3RD GEN
S-A209	218001	GEAR SET 4.33	RS402 LATE EXTENDED SPLINE	3RD GEN
S-A873	218002	GEAR SET 4.56	RS402 LATE EXTENDED SPLINE	3RD GEN
S-C436	218003	GEAR SET 4.88	RS402 LATE EXTENDED SPLINE	3RD GEN
S-9637	218004	GEAR SET 5.29	RS402 LATE EXTENDED SPLINE	3RD GEN
S-D463	218998	GEAR SET 3.55	DP,DT402	3RD GEN
S-D464	218999	GEAR SET 3.70	DP,DT402	3RD GEN
S-D465	219000	GEAR SET 3.90	DP,DT402	3RD GEN
S-16193	219002	GEAR SET 4.33	DP,DT402	3RD GEN
S-11958	219003	GEAR SET 4.56	DS,DT402	3RD GEN
S-D466	219009	GEAR SET 3.55	RP,RT402	3RD GEN
S-D467	219010	GEAR SET 3.70	RP,RT402	3RD GEN
S-D468	219011	GEAR SET 3.90	RP,RT402	3RD GEN
S-11485	219012	GEAR SET 4.11	RP,RT402	3RD GEN
S-D469	219013	GEAR SET 4.33	RP,RT402	3RD GEN
S-10061	219014	GEAR SET 4.56	RP,RT402	3RD GEN



**NEW STAR
NUMBER**

**REPLACEMENT FOR
PART NUMBER**

S-13708 DS461-FSKL / NO FORK

APPLICATION: RT-34-145,40-140,40-145,44-145,RD-20-145

CONSISTS OF ONE EACH:

NEW STAR NUMBER	REPLACEMENT FOR PART NUMBER	DESCRIPTION
S-8951	56360	WASHER
S-8010	79034	WASHER
S-A508	113331	HELICAL GEAR
S-13602	119948	CLUTCH GEAR
S-A187	119995	HELICAL GEAR
S-B251	121681	LOADED CASE ASSEMBLY
S-A257	122418	INPUT SHAFT

LATEST ADDITIONS TO OUR CATALOG

EXCEPT WHERE SPECIFIED, ALL PARTS SUPPLIED ARE S&S/NEWSTAR. USE OF OTHER MANUFACTURERS' NAMES, PART NUMBERS, OR TRADEMARKS ARE FOR INFORMATIONAL AND IDENTIFICATION PURPOSES ONLY.



GEARS AND MISCELLANEOUS PARTS

SUITABLE FOR VARIOUS DANA® (FORMERLY EATON) AXLES

NEWSTAR NUMBER	REPLACEMENT FOR PART NUMBER	DESCRIPTION	APPLICATION MODEL
S-6339	13385	SUPPORT CASE, LH	15040P,T
S-6340	14935	IDLER PIN	16244
S-6341	14938	DOWEL PIN	16220,16244
S-6342	14949	BEARING ADJUSTER LOCK	16244
S-6461	18167	SPIDER	SEE 107371
S-7373	18198	WASHER QTY PKG 4	DS480
S-6344	18199	WASHER QTY PKG 4	DS480
S-4115	18346	WASHER	16244
S-2607	20766	SPIDER	15201
S-6346	20821	IDLER PIN	15200
S-6347	25968	WASHER QTY PKG 10	DS340,400
S-6348	25971	SPIDER	16244
S-11769	27274	WASHER	23105,23121,26121,DS461P,480P,481P,44DS,RS
S-3161	27810	WASHER QTY PKG 12	17,18,34,38
S-3162	27827	WASHER	SEE 127386
S-5794	27835	PINION	17,18221
S-6079	27838	CASE	17,18221
S-6080	27859	SUPPORT CASE, LH	16220
S-7374	27860	CASE	SEE 126009
S-1978	27861	IDLER PIN	17,18,22220
S-7375	27875	IDLER GEAR	16220
S-7376	27952	PINION	44DP,23202,221,321,26221, 321DP,DT460P,481P
S-5793	27953	IDLER PIN	DP,DT481P,DP,DT460P,44DP, 23202,221,321,26221,321
S-5992	32364	SCREW ASSY	15200,23221
S-6352	32401	BEARING	PART OF 122000
S-1929	32861	SWITCH PUSH PULL	15200,23221
S-6355	34779	KIT	DS340,400
S-5513	37069	SIDE GEAR	18,38
S-5795	37071	PINION GEAR	17,18,34,38
S-5796	37072	SIDE GEAR	17,34
S-3330	38208	AXLE SHAFT	38DP,RP,DS,RS
S-7379	38289	SPIDER	17,18,34,38
S-5679	38315	INSULATOR	PART OF 122000
S-8883	40635	MOTOR 2-SPEED	15200,23221
S-7818	43243	SIDE GEAR	18812
S-3166	43270	WASHER	17,18,22221,50DP,RP,34D3B,34R3B,DT
S-5680	43271	THRUST WASHER	18202,222,322
S-6462	43588	SHIM .003 QTY PK 10	SEE 107567
S-6359	43981	AXLE SHAFT	18202,18222,RA192
S-6360	43982	AXLE SHAFT	182,021,822,218,322
S-1712	43983	AXLE SHAFT	182,021,822,218,322
S-6361	44006	AXLE SHAFT	RA146,17202
S-6362	44007	AXLE SHAFT	RA146,17202
S-2000	45476	SIDE GEAR	DS340,400
S-5375	45478	WASHER	DS340,400
S-8221	45480	CLUTCH	DS,DT341,DP,SD,DT381, 500DP,34DSB,DT,401P
S-10451	45481	COVER	34,38DS,DS381,401,402,451,DS340,380
S-6365	45498	SHIM .003 QTY PK 10	DS,DT341/DP,DS,DT381,P, 50DP,34D3B/DP,DS,DT401P
S-6366	45499	SHIM .010 QTY PK 10	DS,DT341/DP,DS,DT381,P, 50DP/34D3B/DP,DS,DT401P
S-6367	45859	FORK	DS340,400
S-5682	46526	O-RING QTY PKG 10	34,38D,DS340,341,380,381
S-8931	46805	12VOLT SOLENOID	—
S-6368	46977	GEAR	DS340,400
S-6369	48921	BUSHING	34D3B
S-5791	48922	BUSHING	44DP/DS34D3B/DS,DT341,381P/DP,DS,DT401P,460P481P
S-5582	49838	SHIFT KIT	SEE 122000
S-A752	51228	BUSHING	DP,DS,DT461P
S-7380	51559	DIFF. CASE	16220,244
S-8723	52112	CASE	15200-15201
S-5753	54254	MAGNETIC PLUG	MULTIPLE APPLICATION

DIFFERENTIAL



LATEST ADDITIONS TO OUR CATALOG

EXCEPT WHERE SPECIFIED, ALL PARTS SUPPLIED ARE S&S/NEWSTAR. USE OF OTHER MANUFACTURERS' NAMES, PART NUMBERS, OR TRADEMARKS ARE FOR INFORMATIONAL AND IDENTIFICATION PURPOSES ONLY.

GEARS AND MISCELLANEOUS PARTS

SUITABLE FOR VARIOUS DANA® (FORMERLY EATON) AXLES

NEW STAR NUMBER	REPLACEMENT FOR PART NUMBER	DESCRIPTION	APPLICATION MODEL
S-3164	54676	WHEEL LOCK	17,18,34,38DS
S-8951	56360	WASHER	DP,DS,DT460P,481P,44DP,DS, DT481P,460P,44P,DP580P,650P
S-5886	56928	CLUTCH PLATE	23202,221,321,26221,321,440P, 460P,481P,580P,650P
S-5887	56929	ADJUSTER	23202,221,321,26221,321,440P DT460P,481P,DP580P,650P
S-5626	56930	SL. CL. GEAR	SEE 113593
S-5882	56931	PLATE	17,18,22220
S-5883	56932	ADJUSTER	17220,18220,22220
S-5515	56933	SL. CL. GEAR	SEE 113596
S-3116	56980	AXLE SHAFT	34DS,17120,17220
S-3330	56981	AXLE SHAFT	38DP,RP,DS,RS
S-6371	58975	AXLE SHAFT	16244
S-6374	60608	KIT-SLIDING CL.	17,18221
S-6375	60609	KIT-SLIDING CL.	19,23,44D,D440P,480P
S-A678	62040	TWO SPEED REDUCTION KIT	34,38,42DP,RP/DP,RP340,380,400
S-6377	62165	AXLE SHAFT	17200,220,34DS
S-6378	62166	AXLE SHAFT	38D,18120,220
S-5318	64085	SEAL	SEE 119855
S-3330	64130	AXLE SHAFT	SEE 56981
S-7381	64467	WASHER	13, 15, 16 SERIES
S-7382	64939	SIDE GEAR	16244-FORD ANGULAR 16 SPLINE
S-7383	64941	PINION GEAR	16244
S-7932	64943	GEAR KIT	USE EAR 102740
S-5813	64944	SIDE GEAR	16244-16 STRAIGHT SPLINE
S-6380	64947	GEAR KIT	16244-16 STRAIGHT SPLINE
S-6381	65360	AXLE SHAFT	15200
S-5611	67592	NUT	17,18,34,38,40
S-6383	70709	SHIM .005 QTY PK 10	DS,DT341/DP,DS,DT381,P,50DP/34D3B/DP,DS,DT401P
S-5374	70745	BOLT KIT	17,18,34,38,40
S-7388	74021	SL. CL. GEAR	SEE 113629
S-5832	74022	ADJUSTER	16220
S-5831	74023	PLATE	16244
S-6063	74054	SL. CL. GEAR	SEE 113599
S-6385	74055	ADJUSTER	15200
S-6386	74056	PLATE	15201
S-7386	74057	PINION	15021
S-6387	74991	GEAR	DS340,400
S-6095	75063	BUSHING	DS,DP,DT481P,DS,DT,DP460P,44DS,DP,DP580P,650P
S-8747	78863	GEAR AND BUSHING ASSY.	DP,DS,DT481P,DS,DT460P,44DS,DP
S-6392	78911	SIDE GEAR	DP,DS,DT481P,DP,DS,DT460P,44DP,DS
S-A103	78915	HELICAL GEAR	DP,DS481P,460P,DP,DT460P
S-A531	78917	SLIDING CLUTCH GEAR	DP,DS,DT460P,DS,DT481P,44DP,DS
S-8663	78931	O-RING	DS,DP,DT440,460,480,461,44DS,DP,DT
S-6393	79005	AXLE SHAFT	18, 23, 26, 44, 440, 480 SERIES
S-8010	79034	THRUST WASHER	DP,DS,DT 460P,481P,44DP,DS, DP580P,650P
S-6378	81216	AXLE SHAFT	SEE 62166
S-6395	81737	CAGE & CUP	1350,13800
S-B845	83726	THRUST WASHER	23070S,23080P,35327,DP,DT,RP,RT461P,485P,521P,550P
S-5848	83799	NUT	44DS
S-C593	84508	SHIFT FORK	44DT-RP,DT-RP-461
S-6396	85358	GEAR KIT	18,38
S-A753	85404	WASHER	50DP/DP,DS,DT341,380,381,401,402,451
S-5684	85429	THRUST WASHER	DP,DS,DT381,401P,50DP,DS,DT381P,341
S-7387	85432	HEL. GR. ASSY.	DS340,400
S-6397	85436	GEAR	DS340,400
S-5894	85437	WASHER QTY PKG 16	DP,DS,DT381,DP,DS,DT401,DS341
S-A650	85439	BEARING	USED W/ 72487
S-6398	85486	SIDE GEAR	DS,RS400
S-3813	85909	GEAR	30,34,38DS
S-5686	85991	BUSHING	DS,DT341,381P,DP,DS,DT381,401P

LATEST ADDITIONS TO OUR CATALOG

EXCEPT WHERE SPECIFIED, ALL PARTS SUPPLIED ARE S&S/NEWSTAR. USE OF OTHER MANUFACTURERS' NAMES, PART NUMBERS, OR TRADEMARKS ARE FOR INFORMATIONAL AND IDENTIFICATION PURPOSES ONLY.



GEARS AND MISCELLANEOUS PARTS

SUITABLE FOR VARIOUS DANA® (FORMERLY EATON) AXLES

NEWSTAR NUMBER	REPLACEMENT FOR PART NUMBER	DESCRIPTION	APPLICATION MODEL
S-7495	85992	WASHER	DS341,381,401
S-5687	85994	SNAP RING QTY PKG 25	DP,DS,DT460P,381P,401P,DP580P 650P,50DP,DS,DT341,3403B
S-6399	85995	CARRIER W/ CAPS	SEE 113644
S-8377	85997	SNAP RING	DS,DT341,381,381P,50DP,401P
S-16110	86780	PINION GEAR	DP485P, DS461P, 466, RS461, DS466P
SA754	86781	WASHER QTY PK OF 4	DP485P,DS461P,RS461,466,DS466P
S-7652	86784	SIDE GEAR	DS480,44DS,23120
S-6402	91850	DIFF. CASE ASSEMBLY	34,38DS
S-10049	93401	SIDE GEAR	23121,26121,DS461P,480P,521P,581P
S-6403	94800	DIFF. CASE ASSEMBLY (1/2" BOLT HOLES)	DS340,380/3.70 TO 5.29 RATIOS
S-7832	94810	PINION GEAR	DS340,380
S-5614	95203	NUT	15200
S-5616	95205	NUT	17,34
S-5617	95206	NUT	17,18,34,38
S-5618	95207	NUT	DS340,400
S-5619	95209	NUT	DS480P
S-6404	95210	PINION GEAR	DS340,400
S-5481	95211	BUSHING QTY PKG 4	DS340,400
S-6405	95212	SPIDER CROSS	DS340,400
S-6406	95213	CASE ASSEMBLY	DS340,400
S-5976	95214	PINION GEAR	DS340,400
S-5754	95215	BRONZE BUSHING QTY 4	DP,DS,DT381,401P,DS,DT341,401P
S-6407	95216	SPIDER	DS340,380,400
S-8749	95217	CASE ASSEMBLY	SEE 213608
S-6408	95218	PINION GEAR	44D
S-5499	95219	BUSHING QTY PKG 4	44DS
S-6409	95220	SPIDER	44D
S-3929	95262	NUT	23221,26121,221,44DP,DS,DP,DS,DT460P,DP,DS,DT481P
S-7493	95371	KIT-SLID. CL.	16,220,244
S-7450	96380	KIT-1/A DIFF.	34D3B
S-6417	96381	KIT-1/A DIFF.	DS,DT341,381P,DP,DS,DT381,401P,50DP
S-6418	96382	KIT-1/A DIFF.	44D
S-6432	96900	PINION GEAR	23202
S-7494	98089	SLIDING CLUTCH KIT	15200
S-7653	98257	SIDE GEAR	23121
S-7685	98581	KIT-WHL. DIFF.	23121
S-D409	98584	CASE ASSEMBLY	23220-1,26085P,T,44DT-RT,DT-RT480, DT,RP440,460
S-5991	98603	KIT-OUTPUT SHAFT	DS340,400
S-6439	98693	INPUT SHAFT W/ NUT	34,38DS,DT
S-6440	98695	INPUT SHAFT W/ NUT	DS,DT440,480P,44DS,DT
S-6443	98850	KIT-WH. DIFF.	17120,34D
S-8343	98852	KIT-WH. DIFF.	18812
S-6444	98853	KIT-WH. DIFF.	DS400
S-9553	99041	BEARING & SEAL KIT	34,38,RP,RT
S-9558	99044	BEARING & SEAL KIT	34,38DS
S-9567	99045	BEARING & SEAL KIT	DP,DS,DT340,380,400
S-9555	99050	BEARING & SEAL KIT	16244,247,344,16220
S-9552	99051	BEARING & SEAL KIT	34,38,42RP,RS,RT340,380,400,17,18 SERIES
S-9554	99096	BEARING & SEAL KIT	44RS,23130,23131
S-5833	101878	CASE ASSEMBLY	17220,18220,22220
S-6452	102500	PINION GEAR	16 SERIES
S-7923	102511	SIDE GEAR	13,15
S-6453	102512	PINION GEAR	15201
S-9323	102613	FORK ASSEMBLY	DT,DP,DS341P W/ LUBE PUMP DT,DP,DS381P,401P W/ LUBE PUMP DT,DP,DS,340,380,400P
S-7683	102737	KIT-WHL. DIFF.	15200,16 ANGULAR SPLINE
S-7924	102738	KIT-WHL. DIFF.	13,15
S-6454	102739	KIT-WHL. DIFF.	16244-STANDARD STRAIGHT SPLINE

DIFFERENTIAL



LATEST ADDITIONS TO OUR CATALOG

EXCEPT WHERE SPECIFIED, ALL PARTS SUPPLIED ARE S&S/NEWSTAR. USE OF OTHER MANUFACTURERS' NAMES, PART NUMBERS, OR TRADEMARKS ARE FOR INFORMATIONAL AND IDENTIFICATION PURPOSES ONLY.

GEARS AND MISCELLANEOUS PARTS

SUITABLE FOR VARIOUS DANA® (FORMERLY EATON) AXLES

NEW STAR NUMBER	REPLACEMENT FOR PART NUMBER	DESCRIPTION	APPLICATION MODEL
S-6455	102740	KIT-WHL. DIFF.	16244-FORD ANGULAR 16 SPLINE
S-3814	103289	INPUT SHAFT W/ NUT	DS340,400
S-5795	104139	PINION GEAR	SEE 37071
S-6457	104456	OUTPUT SHAFT	44DS,DT440/460DS,DT
S-8749	104509	CASE ASSEMBLY	SEE 213608
S-B249	104597	LOADED CASE ASSEMBLY	44DP,DS,DT/DP,DT440,460,480/DS440,460,480
S-10398	106368	REPAIR KIT	DS381,401,402,451P
S-B250	106470	CASE ASSEMBLY	44DS,DP,DT,DS,DT440,460,480
S-6459	106709	INPUT SHAFT W/ NUT	DS340,380,400 W/ LUBE PUMP
S-6403	106974	DIFF. CASE ASSY (1/2" BOLT HOLES)	DS340,380 FOR 3.70 THRU 5.29
S-16548	106975	CASE ASSEMBLY	DS340,380
S-7667	107276	TUBE KIT	GASKET MAKER
S-6461	107371	SPIDER	23121
S-9068	107496	CAGE ASSEMBLY	RS341,402,451 BUILT AFTER 4-6-89 RATIOS 3.08,3.25,3.36,3.90 THRU 7.17
S-6462	107567	SHIM .003 (QTY PK 10)	16244
S-6463	107568	SHIM .005 (QTY PK 10)	16,17,21,22
S-6464	107569	SHIM .010 (QTY PK 10)	16,17,21,22
S-9559	107670	BEARING & SEAL KIT	44RP,RT,19220,221,RP,RT440,460,480
S-10399	107672	REPAIR KIT	DS440,460,480P
S-C002	108141	SPIDER CROSS	DT,RP461,485,DP,RP580,650,26085T,P,30055,35055T,P
S-C051	108142	PINION GEAR	23070S,23080P,T,35327,DP,RP550P,580P,650P,ETC
S-B951	108145	THRUST WASHER	23070S,23080P,T,35327,DP,DT461P,485P,521P,601P,651
S-6466	109237	CAPSCREW	15040T,15200
S-6467	109238	CAPSCREW	19050T,16244
S-5834	110148	CASE 1/2	22221,321
S-7931	110243	ADJUSTER	22221,321
S-8359	110522	SIDE GEAR	15200
S-6468	110524	SIDE GEAR	16244
S-7905	110525	SIDE GEAR	DS,RS341
S-5689	110527	SIDE GEAR	22421,DT381
S-5690	110528	SIDE GEAR	DS,DT440P
S-D699	110733	CAGE ASSEMBLY	DP,DS,DT341,381,401,402
S-6469	110810	SIDE GEAR	DS,DT341,DP,DS,DT381,DP,DS,DT401P
S-6480	110818	SHAFT BUSHING ASSY	SEE 115123
S-D724	110826	COVER ASSEMBLY	DS402
S-8241	110844	OUTPUT HELICAL GEAR	SEE 128042
S-6471	110845	PINION	DS341,381,401
S-6980	110880	AXLE SHAFT	F106
S-6472	110882	AXLE SHAFT	34D,D340,341,17221
S-6473	110884	AXLE SHAFT	18,22,38,380,381
S-A748	110885	AXLE SHAFT	23321,26221,321,421,431,23121,H172
S-6474	110886	AXLE SHAFT	17,34,340,341
S-8436	110888	AXLE SHAFT	DS-381,RS-381
S-F124	110889	AXLE SHAFT	DS, RS-461
S-F125	111544	AXLE SHAFT	15040S, T
S-C295	113329	HELICAL GEAR	DP,DS,DT440P,460P,480P
S-A508	113331	HELICAL GEAR & BUSHING ASSY	DP,DS,DT461P,DP,DT460P,DS,DT481P, DS480P,446P
S-15582	113514	OIL SEAL	SUBMERSIBLE
S-8575	113556	HELICAL GEAR, PINION	DS380,381,400,401,DT380,381,400,401
S-8882	113561	HELICAL GEAR KIT	DS341,381,401
S-5626	113593	SL. CL. GEAR	23201,221,26221,DT460P,481P
S-A255	113594	SLIDING CLUTCH	DT485
S-5515	113596	SL. CL. GEAR	17,18
S-9081	113598	SUN GEAR	DP,DT,RP,RT381
S-6063	113599	SL. CL. GEAR	15201
S-7388	113629	SL. CL. GEAR	16244
S-6399	113644	CARRIER W/ CAPS	19050T
S-9733	113645	AXLE SHAFT	16244

LATEST ADDITIONS TO OUR CATALOG

EXCEPT WHERE SPECIFIED, ALL PARTS SUPPLIED ARE S&S/NEWSTAR. USE OF OTHER MANUFACTURERS' NAMES, PART NUMBERS, OR TRADEMARKS ARE FOR INFORMATIONAL AND IDENTIFICATION PURPOSES ONLY.



GEARS AND MISCELLANEOUS PARTS

SUITABLE FOR VARIOUS DANA® (FORMERLY EATON) AXLES

NEW STAR NUMBER	REPLACEMENT FOR PART NUMBER	DESCRIPTION	APPLICATION MODEL
S-C634	113743	SHIFT HOUSING ASSEMBLY	2-SPEED
S-5691	113744	CIRCUIT BOARD ASSY.	2-SPEED
S-6058	113745	SHIFT MOTOR	2-SPEED, NEW STYLE
S-A760	113753	HARNESS & CONNECTOR	2-SPEED
S-A761	113759	SLIDER & SHAFT ASSY	2-SPEED SHIFT MOTOR
S-5692	114242	GEAR KIT	16 SERIES
S-6477	114245	GEAR KIT LESS SPIDER	16 SERIES
S-9571	114394	BEARING & SEAL KIT	DS,341,381,381P,401P
S-7686	114467	GEAR KIT	15201
S-7925	114469	GEAR KIT	DS,RS341
S-5693	114470	GEAR KIT	DS381,P,401P,18,21,22,38,380,381,402
S-8174	114474	GEAR KIT	DS440P,460P,23,26
S-6478	114479	GEAR KIT LESS SPIDER	DS381,P,401P,18,21,22,38,380,381,402
S-C410	115122	INPUT SHAFT ASSY	DS341,381,401
S-6480	115123	OUTPUT SHAFT ASSY	DS341,381,401
S-6481	115126	INPUT SHAFT ASSY	DS341,381,401P
S-6482	116568	SUPPORT CASE KIT	22221,321
S-13222	118746	GEAR KIT	15201
S-7831	118748	GEAR KIT	17,18,21,38,380,381,401,402
S-9157	118806	SLOTTED PINION NUT	DS,DT,DP341,381,401,402,451
S-9159	118807	ROLL PIN (QTY PK 10)	USE WITH 118806
S-6981	118866	AXLE SHAFT	F106
S-C052	118959	SIDE GEAR	23070S,23105S,30105S,DP,DT,RP,RT461P,485P,521P
S-D849	119393	GEAR KIT	DT,RT461
S-5366	119427	OIL SEAL	DP,DS,DT340,341,380,381,DS400P,401P,16244
S-8250	119429	OIL SEAL	DP,DS381P,DP401P,DS,DT481P
S-7207	119431	OIL SEAL	DS340,341,380,381
S-5694	119432	OIL SEAL	23121,421,481,17401,21
S-5366	119457	OIL SEAL	DP,DS,DT340,341,380,381,DS400P,401P,16244
S-9511	119594	AXLE SHAFT	22065S,G190S,M220S,M190T,M210T,21121,17421,17221,17202,17222,340SB,DT,DS341
S-8903	119595	AXLE SHAFT	DP,DS,DT,RP,RS,RT381,402
S-5318	119855	OIL SEAL	2-SPEED
S-E783	119927	AXLE SHAFT	19055S-D
S-13602	119948	SLIDING CLUTCH	DS,DP,DT440P,460P,461P,480P,485P,521P,601P,651P
S-A187	119995	HELICAL GEAR	DP,DS,DT461P,DS466P,DT521P,
S-A762	120750	SHIFT UNIT ASSY	2-SPEED SHIFT MOTOR
S-10092	121302	REPAIR KIT	DS,DT461P,521P,581P, NO COVER AND BOLTS
S-B251	121681	DIFF CASE ASSEMBLY	DP,DS,DT461,521,581
S-9970	121748	GEAR KIT	19050S,T
S-A680	121749	DIFF KIT	LESS SIDE GEARS 19050S,T
S-11196	121785	GEAR KIT	23070S,23105S,30105S,DP,DT,RP,461P,485P,521P
S-5582	122000	SHIFT KIT	2-SPEED
S-A257	122418	INPUT SHAFT	DP,DS461P,DT461P,DS466P,DT521P
S-A555	122419	OUTPUT SHAFT	DS,DT461,521,581,601,651
S-D848	122420	REPAIR KIT	DT,RT461
S-9780	126000	SIDE GEAR	19050S,T
S-9781	126001	PINION GEAR	19050S,T
S-9853	126002	SPIDER	19050S,T
S-9829	126003	WASHER	19050T
S-A563	126004	WASHER	19050T
S-9472	126009	CASE	19050T
S-B846	126152	SPIDER	DS461P,521P,581P,DP, DT461P,521P,601P,651P
S-8956	126155	NUT,INPUT SHAFT	DS461,521-581-P,DT461,521-581-P
S-B847	126180	THRUST WASHER	DP,DS,DT461P,521P,581P
S-A135	126182	PINION NUT (METRIC)	DP,DS,DT461P,DP401P,DT402P,DS402,DS404,DS466P
S-B844	126255	SLIDING CLUTCH GEAR	RP,RT461,521,601,651
S-9218	126274	AXLE SHAFT	19050T-S
S-5887	126305	ADJUSTER	23202,221,321,26221,321,44DP,DT460P
S-A465	126306	IDLER PINION	481P,DP580P,650P DT,RT461,521,581,601,651

DIFFERENTIAL



LATEST ADDITIONS TO OUR CATALOG

EXCEPT WHERE SPECIFIED, ALL PARTS SUPPLIED ARE S&S/NEWSTAR. USE OF OTHER MANUFACTURERS' NAMES, PART NUMBERS, OR TRADEMARKS ARE FOR INFORMATIONAL AND IDENTIFICATION PURPOSES ONLY.

GEARS AND MISCELLANEOUS PARTS

SUITABLE FOR VARIOUS DANA® (FORMERLY EATON) AXLES

NEW STAR NUMBER	REPLACEMENT FOR PART NUMBER	DESCRIPTION	APPLICATION MODEL
S-C388	126307	CLUTCH PLATE	23080P,T,DP,DS461P,521P,601P,651P,RP,RT461,521,601
S-A791	127051	BEARING	DS402
S-B425	127138	AXLE SHAFT	DS4461P
S-11194	127359	SPIDER	DS404
S-11193	127364	PINION GEAR	DS404
S-D474	127368	SIDE GEAR	DS404
S-B953	127386	WASHER	DS404,454,RS404,454
S-D884	127437	AXLE SHAFT	DS404,RS404
S-D885	127438	AXLE SHAFT	DS404,RS404
S-16338	127455	BOLT	DS404
S-A919	127495	HELICAL GEAR & BUSHING ASSY	DS404
S-C306	127510	SLIDING CLUTCH GEAR	DS344,404(P),454P,DD404(P),454P
S-A789	127523	PINION DRIVE GEAR	DS404,454
S-F028	127545	O-RING	DS404
S-B025	127588	OUTPUT SHAFT NUT	DS404
S-9833	127589	HEX NUT (METRIC)	PINION SHAFT 19055S,22065S,21060S,RS404,RD404
S-B140	127591	OIL SEAL	DS404
S-B141	127592	OIL SEAL	DS404
S-F083	127595	SHIM .003	DS404
S-F084	127596	SHIM .005	DS404
S-F085	127597	SHIM .010	DS404
S-F086	127598	SHIM .020	DS404
S-F087	127599	SHIM .030	DS404
S-D675	127645	SIDE GEAR	DS404
S-7872	127719	OIL SEAL, NEW STYLE	DP,DS381,DP401P,DS,DT481P
S-7207	127720	OIL SEAL	DS340,341,380,381
S-5366	127721	OIL SEAL	DP,DS,DT340,341,380,381,DS400P,401P,16244
S-9062	127783	SPIDER	DS341,381,402,451
S-B952	127785	WASHER	DS341,402,P,451P,DP,DT341,381,P,401P,402,P,451P
S-6364	128016	CLUTCH GEAR	DS,DT341,DP,DS,DT381,DT401P,50DP,34DSB
S-8241	128042	OUTPUT HELICAL GEAR	DS341,381,401
S-A794	128049	PINION METRIC NUT	DS404,23080D,S,23085D,S
S-E633	128516	AXLE SHAFT	DS454,RD404,22060S,D
S-C385	128634	CASE ASSEMBLY	DS344,404,P
S-10176	128702	THRUST WASHER	DS404,RS404
S-E035	128703	OIL SEAL	DS404
S-B954	129305	WASHER	DS404,454,RS404,454
S-F042	129594	SNAP RING	DS404
S-E120	129783	SHIFT FORK	DS404
S-14008	210180	O-RING	23080,23085,21065,DS404,454,RD404
S-8373	210508	PINION NUT	23070P,T,26085,P,T,30,35055P,RS461, 521,581/RT,RP461,521,601,651
S-9218	210512	AXLE SHAFT	19050T-S
S-9218	210628	AXLE SHAFT	19050T-S
S-A258	210724	OIL SEAL	RS461,521,581,RT,RP461,521,601,651
S-12000	210736	OIL SEAL	DS461P,521P,581P,DT,DT461P,521P,601P,651P
S-12001	210737	OIL SEAL	DS461P,521P,581P
S-8008	211319	KIT	2-SPEED BOARD & COVER W/ HDWE
S-12095	211634	COVER & SEAL ASSY.	DS341,381,402 W/O LUBE PUMP
S-E028	213176	END YOKE W/ SEAL	DS402-1.75"-34 SPLINES
S-E134	213177	END YOKE W/ SEAL	DS402-1.75"-34 SPLINES-HI ANGLE
S-C539	213179	END YOKE W/ SEAL	HI-ANGLE 2.024"-39 SPLINE-DS402
S-E125	213181	END YOKE W/ SEAL	RS402- 2.016-39 SPLINES
S-8749	213608	COMP. DIFF. ASSY.	DS340,341,380,381
S-F022	216220	OVERHAUL KIT	DS404
S-12100	216221	OVERHAUL KIT	RS404
S-A920	216226	INPUT SHAFT KIT	DS404
S-A870	216227	OUTPUT SHAFT KIT	DS404
S-13751	216228	GEAR KIT	DS404
S-E712	216229	GEAR KIT	DS404

LATEST ADDITIONS TO OUR CATALOG

EXCEPT WHERE SPECIFIED, ALL PARTS SUPPLIED ARE S&S/NEWSTAR. USE OF OTHER MANUFACTURERS' NAMES, PART NUMBERS, OR TRADEMARKS ARE FOR INFORMATIONAL AND IDENTIFICATION PURPOSES ONLY.



GEARS AND MISCELLANEOUS PARTS

SUITABLE FOR VARIOUS DANA® (FORMERLY EATON) AXLES

NEW STAR NUMBER	REPLACEMENT FOR PART NUMBER	DESCRIPTION	APPLICATION MODEL
S-C303	508652	METRIC BOLT KIT	DS404,RS404
S-F521	508653	CASE ASSEMBLY	DS404 RATIOS 2.64 TO 3.25
S-E316	508654	CASE ASSEMBLY	DS404,454 RATIOS 3.36 TO 3.90
S-E317	508655	CASE ASSEMBLY	DS404,454 RATIOS 4.11 TO 4.88
S-8174	935289	GEAR KIT	DS440P,460P,23,26
S-9698	DS-402-FSKL	REPAIR KIT	DS402
S-E110	DS-402-FSKLP	REPAIR KIT W/ PUMP	DS402
S-D678	DS-404-FSKL	REPAIR KIT	DS404
S-13708	DS-461-FSKL	REPAIR KIT / NO FORK	FRONT SECTION - DP, DT461,521,601,651,P
S-9552	RA1	BEARING & SEAL KIT	34,38,42,RP,RS,RT340,380,400
S-9553	RA1A	BEARING & SEAL KIT	34,38,RP,RT W/ CONICAL CARRIER
S-9554	RA18A	BEARING & SEAL KIT	44RS,23130,23131
S-9555	RA23D	BEARING & SEAL KIT	16444,247,344,16220 W/ 15 1/2 RING GEAR
S-9558	RA64FD	BEARING & SEAL KIT	34,38DS, W/ CONICAL CARRIER
S-9559	RA72A	BEARING & SEAL KIT	44RP,RT,19-220,221,RP,RT440,460,480
S-9571	RA196	BEARING & SEAL KIT	DS341,381,P,401,P
S-9755	RA207	BEARING & SEAL KIT	DP,DT341,381,P401P,402,P,451 P,
S-B069	RA208	BEARING & SEAL KIT	DS440P,460P,461P,521P,581P
S-A087	RA210	BEARING & SEAL KIT	DP,DT440P,DT460P,DP480P
S-B008	RA211F	BEARING & SEAL KIT	PP461P,DT461P,DP,DT485P,521P,601P,651P
S-C672	RA219R	BEARING & SEAL KIT	RP,RT461,521,601
S-9579	RA222F	BEARING & SEAL KIT	DS341,402,451 AFTER 4/6/89
S-9580	RA222R	BEARING & SEAL KIT	RS341,402,451 AFTER 4/6/89
S-B937	RA404F	BEARING & SEAL KIT	DS404
S-B938	RA404R	BEARING & SEAL KIT	RS404

DIFFERENTIAL



LATEST ADDITIONS TO OUR CATALOG

EXCEPT WHERE SPECIFIED, ALL PARTS SUPPLIED ARE S&S/NEWSTAR. USE OF OTHER MANUFACTURERS' NAMES, PART NUMBERS, OR TRADEMARKS ARE FOR INFORMATIONAL AND IDENTIFICATION PURPOSES ONLY.

TWO SPEED PARTS

SUITABLE FOR DANA® (FORMERLY EATON) AXLES

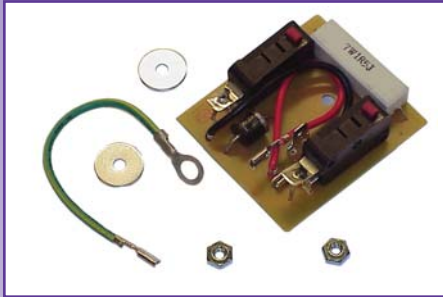

CIRCUIT BOARD

NEW STAR
NUMBER

S-5691

REPLACEMENT FOR
PART NUMBER

113744

SHIFT MOTOR

NEW STAR
NUMBER

S-6058

REPLACEMENT FOR
PART NUMBER

113745



NEW STAR
NUMBER

S-8883

REPLACEMENT FOR
PART NUMBER

40635

ELECTRIC SHIFT RETRO UNIT

NEW STAR
NUMBER

S-C634

REPLACEMENT FOR
PART NUMBER

113743



HARNESS & CONNECTOR

NEW STAR
NUMBER

S-A760

REPLACEMENT FOR
PART NUMBER

113753



TWO SPEED PARTS

SUITABLE FOR DANA® (FORMERLY EATON) AXLES



SLIDER AND SHAFT ASSY.

NEW STAR
NUMBER

S-A761

REPLACEMENT FOR
PART NUMBER

113759

ELECTRIC SHIFT UNIT W/BOOT (NO HARNESS & HARDWARE)

NEW STAR
NUMBER

S-A762

REPLACEMENT FOR
PART NUMBER

120750



CIRCUIT BOARD KIT W/ COVER & HARDWARE

NEW STAR
NUMBER

S-8008

REPLACEMENT FOR
PART NUMBER

211319



CONVENIENCE KITS

SUITABLE FOR DANA® (FORMERLY EATON) AXLES

DS402 FRONT SECTION REPAIR KIT

NEW★STAR NO. S-9698

REPLACEMENT FOR PART NUMBER: DS402PACK

APPLICATION:

DS381, 401, 402LATE

CONSISTS OF ONE EACH:

**NEW★STAR
NUMBER**

**REPLACEMENT FOR
PART NUMBER:**

S-C410	115122
S-8241	128042
S-6364	128016
S-8749	213608
S-5375	45478
S-6367	45859
S-6469	110810



DS402 FRONT SECTION REPAIR KIT

NEW★STAR NO. S-E110

REPLACEMENT FOR PART NUMBER: DS-402-FSKLP

APPLICATION:

DS381, 401, 402LATE WITH PUMP

CONSISTS OF ONE EACH:

**NEW★STAR
NUMBER**

**REPLACEMENT FOR
PART NUMBER:**

S-8241	128042
S-6364	128016
S-8749	213608
S-5375	45478
S-6367	45859
S-6469	110810
S-6481	115126



DS404 FRONT SECTION REPAIR KIT

NEW★STAR NO. S-D678

REPLACEMENT FOR PART NUMBER: DS404PACK

APPLICATION:

DS404

CONSISTS OF ONE EACH:

**NEW★STAR
NUMBER**

**REPLACEMENT FOR
PART NUMBER:**

S-A919	127495
S-C306	127510
S-D675	127645
S-C385	128634
S-A920	216226



REPLACEMENT RING GEAR AND PINION SETS

APPLICATION: FORD AXLES FOR STOCK & STREET PERFORMANCE APPLICATIONS



NEW★STAR NUMBER	REPLACEMENT FOR			RATIO	APPLICATION
	FORD NUMBER	STRANGE NUMBER	RICHMOND GEAR NUMBER		
S-8577	B7AZ-4209-E	07-890389	69-0177-1	3.89	9" - 10 BOLT
S-6027	C9OZ-4209-A	07-890350	49-0027-1	3.50	9" - 10 BOLT
S-8725	M4209D620	07-890620	69-0290-1	6.20	9" - 10 BOLT
S-9279	E4SZ-4209-A	07-875373	49-0043-1	3.73	7.5" - 10 BOLT
S-8792	E7AZ-4209-A	—	—	3.27	8.8" - 10 BOLT
S-8793	E7TZ-4209-A	—	—	3.08	8.8" - 10 BOLT
S-8466	F3TZ-4209-A	07-888373F	49-0104-1	3.73	8.8" - 10 BOLT
S-8182	E5TZ-4209-D	—	—	4.10	10.25" - 12 BOLT
S-9317	F10.25-456	—	—	4.56	10.25" - 12 BOLT

REPLACEMENT INSTALLATION KITS

APPLICATION: FORD AXLES
CONSISTING OF ALL BEARINGS, SHIMS, SLEEVE, PINION NUT, BOLTS AND GASKETS

NEW STAR NUMBER	REPLACEMENT FOR PART NUMBER	DESCRIPTION	APPLICATION
S-8468	R9AXB	INSTALLATION KIT	9"
S-8517	R88XB	INSTALLATION KIT	8.8"
S-8475	R1025XB	INSTALLATION KIT	10.25"
S-8812	—	SHIM KIT, PINION CAGE	8.8"
S-8813	—	SHIM KIT, PINION CAGE	10.25"
S-9723	—	MASTER SHIM KIT	8.8"
S-9498	—	CARRIER SHIM KIT	8.8"



REPLACEMENT BEARING AND SEAL KITS

APPLICATION: FORD AXLES

NEW STAR NUMBER	REPLACEMENT FOR PART NUMBER	APPLICATION
S-9533	RA311	8.8"
S-D585	RA311F	8.8" FRONT 1997 & LATER
S-9537	RA314	10.25"
S-9538	RA315	7.5"
S-D582	RA316	9.75" 1997 & LATER
S-D583	RA316A	9.75" 1999 & LATER
S-D584	RA317	10.25" 1999 & LATER

REPLACEMENT MISCELLANEOUS PARTS

APPLICATION: FORD AXLES

NEW STAR NUMBER	REPLACEMENT FOR PART NUMBER	DESCRIPTION	APPLICATION
S-9300	E2TZ-4676-A	OIL PINION SEAL	9"
S-9042	E7TZ-4204-C	DIFF. CASE - EMPTY	10.25"
S-9714	E7TZ-4209-BMK	MASTER KIT	8.8" - 10 BOLT 3.55
S-9177	E5TZ-4209-DMK	MASTER KIT	10.25" - 12 BOLT 4.10
S-9182	D5AZ-4216-A	BOLT, RING GEAR	8.8"
S-9183	D80Z-4216-B (F4TZ-4216-A)	BOLT, RING GEAR	9"
S-9184	E5TZ-4216-A	BOLT, RING GEAR	10.25"
S-8892	E7TZ-4234-B	AXLE SHAFT	8.8" LH - 31 SPLINE '1987' & LATER MODELS
S-9299	E8TZ-4676-B	OIL PINION SEAL	10.25"
S-9297	E8TZ-4676-C	OIL PINION SEAL	8.8"
S-9165	B7A-4662-A	CRUSH SLEEVE	9", 8.8", 10.25"
S-B624	E7TZ-4851-A	FLANGE YOKE	10.25" - 31 SPLINES
S-8590	10.25-12 BOLT	DIFF. KIT	10.25"
S-9480	8.8-12 BOLT	INTERNAL KIT	8.8" - 31 SPLINE

REPLACEMENT RING GEAR AND PINION SETS

APPLICATION: VARIOUS GM AXLES

NEW★STAR NUMBER	REPLACEMENT FOR PART NUMBER	DESCRIPTION	APPLICATION
S-8367	3717212	GEAR SET 5.83	T150
S-7232	3718101	GEAR SET 7.20	H150,170
S-7233	3886301	GEAR SET 5.83	T170

REPLACEMENT GEARS AND PINION SETS

APPLICATION: VARIOUS GM AXLES

NEW★STAR NUMBER	REPLACEMENT FOR PART NUMBER	DESCRIPTION	APPLICATION
S-6624	359339	PINION GEAR	T150,T170
S-6619	3708817	PINION GEAR	H150,170
S-6620	3708818	SIDE GEAR	H150,170
S-6623	3873573	SPIDER	T150,T170
S-6624	3873574	PINION GEAR	T150,T170
S-6625	3873576	SIDE GEAR, LH	T150,T170
S-6626	3873577	SIDE GEAR, RH	T150,T170
S-6628	3873581	IDLER PINION	T150,T170
S-6629	3874327	ANCHOR	T150,T170
S-3446	3874345	SLEEVE	T150,T170
S-9560	8873475	BEARING & SEAL KIT	T170 ALL, 150 Prior to 1983

DIFFERENTIAL



LATEST ADDITIONS TO OUR CATALOG

EXCEPT WHERE SPECIFIED, ALL PARTS SUPPLIED ARE S&S/NEWSTAR. USE OF OTHER MANUFACTURERS' NAMES, PART NUMBERS, OR TRADEMARKS ARE FOR INFORMATIONAL AND IDENTIFICATION PURPOSES ONLY.

REPLACEMENT RING GEAR AND PINION SETS

APPLICATION: VARIOUS GM AXLES



NEW★STAR NUMBER	REPLACEMENT FOR				RATIO	APPLICATION
	GM NUMBER	NEW GM NUMBER	STRANGE NUMBER	RICHMOND GEAR NUMBER		
S-7978	471871	26014192	—	—	3.73	10.5" 14 BOLT
S-8179	471872	26014193	—	—	4.10	10.5" 14 BOLT
S-8180	471873	26014194	—	—	4.56	10.5" 14 BOLT
S-8175	1258710	26041514	01-885342	49-0278-1	3.42	8.5" 10 BOLT
S-9111	471879	—	01-888373	49-0280-1	3.73	8.8" 12 BOLT

REPLACEMENT BEARING AND SEAL KITS

APPLICATION: GM AXLES

NEW★STAR NUMBER	REPLACEMENT FOR PART NUMBER	APPLICATION
S-9540	RA321	8.5"
S-D580	RA321CMK	8.5" 1999 & LATER
S-9541	RA322	8.875" TRUCK
S-9542	RA323	8.875" CAR
S-9543	RA324	9.5"
S-9544	RA325	10.5" BELOW '88
S-9545	RA325A	10.5" '88 & UP

REPLACEMENT INSTALLATION KITS

APPLICATION: GM AXLES

CONSISTING OF ALL BEARINGS, SHIMS, SLEEVE, PINION NUT, BOLTS AND GASKETS



NEW★STAR NUMBER	REPLACEMENT FOR PART NUMBER	DESCRIPTION	APPLICATION
S-8477	R625GXB	INSTALLATION KIT	7.5"
S-8536	R10FRXB	INSTALLATION KIT	8.5"
S-9232	R12RXB	INSTALLATION KIT	8.8"
S-8535	R1495XB	INSTALLATION KIT	9.5"
S-8495	R14XB	INSTALLATION KIT ('88 & BELOW)	10.5"
S-8812	SH1012	SHIM KIT, PINION CAGE	7.5", 8.5"
S-9498	SH1101	SHIM KIT, SIDE CARRIER	8.8"
S-8813	SH1102	SHIM KIT, PINION CAGE	9.5"
	-14038011		
S-8814	SH14	SHIM KIT	10.5"
S-9499	SH1104	SHIM KIT, PINION CAGE	8.8"
S-9707	SH1105	CARRIER SHIM KIT	7.5", 8.5"
S-9708	—	MASTER SHIM KIT	7.5", 8.5"
S-9713	—	MASTER SHIM KIT	8.8"

REPLACEMENT DIFFERENTIAL SIDE GEAR AND PINION SETS

APPLICATION: GM AXLES

NEW★STAR NUMBER	REPLACEMENT FOR PART NUMBER	APPLICATION
S-9036	8.5-10 BOLT (26019852)	DIFF. KIT 28 SPLINE
S-8593	8.8-12 BOLT	DIFF. KIT
S-8592	9.5-14 BOLT	DIFF. KIT

REPLACEMENT MISCELLANEOUS AXLE PARTS

APPLICATION: GM AXLES

NEW STAR NUMBER	REPLACEMENT FOR PART NUMBER	DESCRIPTION	APPLICATION - MODEL
S-9185	181056	GASKET, HOUSING	7.5"
S-9186	331421	BOLT, RING GEAR	10.5"
S-9302	458859	OIL PINION SEAL	8.5"
S-9187	458860	GASKET, HOUSING	8.5" - CAR
S-9188	644536	PINION NUT	10.5"
S-9647	1234726	CRUSH SLEEVE	8.5"
S-9295	1243465	OIL PINION SEAL	8.5"
S-9189	1260823	PINION NUT	7.5", 8.5", and 9.5"
S-9321	3924031	OIL PINION SEAL	8.8"
S-15669	3954480	CRUSH SLEEVE	8.8" (AUTO)
S-F435	3954482	CRUSH SLEEVE	8.8"
S-9190	3977387	GASKET, HOUSING	10.5"
S-9191	3993593	GASKET, HOUSING	8.5" - TRUCK
S-9325	3998513	GASKET, HOUSING	8.8"
S-9396	6258336	DIFFERENTIAL CASE	10.5" - 14 BOLT 4.10 RATIOS & BELOW
S-9395	6258340	DIFFERENTIAL CASE	10.5" - 14 BOLT 4.56 RATIOS & UP
S-9753	9785792	CRUSH SLEEVE	7.5"
S-9310	14003451	BOLT, RING GEAR	8.8"
S-9298	14012694	OIL PINION SEAL	9.5"
S-9192	14012703	BOLT, RING GEAR	9.5"
S-9301	14039587	OIL PINION SEAL	7.5", 8.5"
S-9193	14066913	BOLT, RING GEAR	7.5" and 8.5"
S-8894	14071750	AXLE SHAFT	8.8" - 12 BOLT 30 SPLINE - 6 LUG SUBURBAN PICK-UP 4X4
S-A366	14071751	AXLE SHAFT	8.8" - 12 BOLT 30 SPLINE - 5 LUG 2 WD PICK-UP
S-9296	26004811	PINION OIL SEAL	10.5"
S-8896	26010416	AXLE SHAFT	8.5" - 10 BOLT 30 SPLINE - 6 LUG 4WD - PICK-UP
S-9190	26012845	GASKET, HOUSING	10.5"
S-B824	26013313	AXLE SHAFT	8.5" - 10 BOLT LENGTH 33 5/16" - 30 SPLINES - 5 HOLE
S-9830	26013882	AXLE SHAFT	7.625" S10 & S15 - 28 SPLINE 4WD
S-9709	—	MINI INSTALLATION KIT*	8.5"
S-B085	26015584	SLIP YOKE	MIDSHIP
S-8258	26020811	FLANGE YOKE 1350 SERIES	10.5" -14 BOLT AXLES - 30 SPLINES

*CONSISTS OF SEAL, SHIMS, NUT, COLLAR, AND GASKET

LATEST ADDITIONS TO OUR CATALOG

EXCEPT WHERE SPECIFIED, ALL PARTS SUPPLIED ARE S&S/NEWSTAR. USE OF OTHER MANUFACTURERS' NAMES, PART NUMBERS, OR TRADEMARKS ARE FOR INFORMATIONAL AND IDENTIFICATION PURPOSES ONLY.



GENUINE RING GEAR AND PINION SETS

APPLICATION: VARIOUS GM AXLES

GENUINE PART NUMBER	DESCRIPTION	GENUINE PART NUMBER	DESCRIPTION
393132	PINION SHAFT BOLT	26051483	FORGED SIDE GEAR
3663696	SPIDER	26051484	PINION GEAR
3901141	REV. IDLER GEAR	26051485	SIDE GEAR
3901164	HUB	26051486	PINION GEAR
3901165	CLUTCH SLEEVE	26051487	SIDE GEAR
3977345	SIDE GEAR WASHERS	26054981	GEAR SET 3.73
3977346	PINION WASHER	26054990	4:56 GEAR SET
3984818	WASHER	26054993	GEAR SET
3988515	GEAR SET 4:10	26054996	GEAR SET 3.73
3993448	PINION GEAR	26056109	SHAFT
8672408	MAIN DRIVE GR 1 1/8"-USE 211F	26058344	3:42 GEAR SET GM 14 BOLT 9.5"
8672409	MAIN DR GEAR USE 211FFLE BRG	26060032	GEAR SET 4.11
9428890	PINION BOLT	26060033	GEAR SET 3.73
9783762	NUT-PIN.FLANGE	26060034	GEAR SET 3.42
12337937	WASHER	26060058	4:56 GEAR SET
12375622	GEAR KIT	26060061	4:11 GEAR SET
12471427	4:10 GEAR SET	26060065	3:73 GEAR SET
12471428	3:73 GEAR SET	26060068	3:42 GEAR SET
12471429	3:42 GEAR SET	26060748	DIFF CASE-NEW STYLE
12471541	PINION GEAR	26060882	YOKE
12479021	OPEN CASE	26062828	PINION GEAR-11T-3"
14012696	SIDE GEAR	26062829	SIDE GEAR
14012699	PINION WASHER	26063838	WASHER
14012702	LOCK BOLT	40000160	(OEM) THRUST WASHER-SIDE GEAR
14038087	CASE	40000278	EMPTY CASE
14039589	PINION SHAFT FOR GM 7.25" IFS	40000384	(OEM) SIDE GEAR-NEW STYLE
14039596	DIFF CASE FOR GM 7.25" IFS	40000918	SIDE GEAR-28T
14039598	NOT FOR INDV. SALE (IN KITS)	40001429	SCREW-PINION
14039599	WASHER 7.5IFS	40002211	WASHER-SIDE GEAR
14056196	PIN QUANTITY PACK 10 EA.	40002212	WASHER-PINION GEAR
14066913	BOLT, RING GEAR	40003027	NUT-PINION
15588350	WASHER	40005982	3:73 GEAR SET
15588351	WASHER	40005985	4:10 GEAR SET
26008632	3:08 GEAR SET	40005991	4:63 GEAR SET
26010481	CASE	40007237	3.42 GEAR SET
26014585	GEAR SET 4.11	40007448	CROSS PIN
26016310	4:30 GEAR SET	40007876	(OEM) DIFF. CASE
26016528	4.10 GEAR SET	40014964	WASHER-PINION
26018131	CASE	10.5-14 BOLT	INTERNAL KIT
26019418	PINION GEAR	14066913X	BOLT KIT QTY 10 (7.25/8.25IFS)
26019419	SIDE GEAR	14066913XX	BOLT KIT-QTY.12 (GM9.25" IFS)
26019829	GEAR KIT	7.25IFS	INTERNAL KIT
26019852	GEAR KIT	8.25IFS	INTERNAL KIT
26021111	SIDE GEAR RH	9.25IFS	INTERNAL KIT
26033477	CASE	9.5-14 BOLT	INTERNAL KIT
26034788	SIDE GEAR-26S	GM10B8.0-28	INTERNAL KIT
26034789	PINION GEAR GM 7.25" IFS	GM8.6GMT800	INTERNAL DIFF KIT-99-MID 2000
26035261	3:73 GEAR SET GM IFS	GM8.6GMT820	INTERNAL DIFF KIT MID 2000-CUR
26035826	GEAR SET 3.73		
26035835	GEAR SET 3.08		
26036813	GEAR SET 3.73		
26039760	GEAR SET 3.08		
26039764	3:42 GEAR SET GM 7.25" IFS		
26041321	PINION SHAFT		
26043281	2:73 GEAR SET		
26045345	GEAR SET 3.42		
26051478	PINION GEAR		
26051479	SIDE GEAR		
26051480	FORGED PINION GEAR		
26051481	RIGHT HAND SIDE GEAR		

DIFFERENTIAL



REPLACEMENT RING GEAR AND PINION SETS

APPLICATION: INTERNATIONAL TRUCK AXLES



NEW STAR NUMBER	REPLACEMENT FOR PART NUMBER	DESCRIPTION	APPLICATION - MODEL
S-6356	68907R94	GEAR SET 6.50	RA39
S-7378	69015R93	GEAR SET 7.17	RA30
S-5253	69021R93	GEAR SET 5.29	RA30
S-7377	69022R93	GEAR SET 6.17	RA30
S-7249	578793C91	GEAR SET 5.38	RA30
S-9131	597140C91	GEAR SET 5.57	M190T,M210T,M220T,M230T
S-10895	597141C91	GEAR SET 6.14	M190T,M210T,M220T,M230T
S-8606	597236C91	GEAR SET 3.55	RA351,355,472
S-7250	597237C91	GEAR SET 3.73	RA351,355,472
S-7251	597238C91	GEAR SET 3.91	RA351,355,472
S-7252	597239C91	GEAR SET 4.10	RA351,355,472
S-7253	597240C91	GEAR SET 4.44	RA351,355,472
S-7254	597241C91	GEAR SET 4.77	RA351,355,472
S-7255	597242C91	GEAR SET 5.37	RA351,355,472
S-7256	597243C91	GEAR SET 6.14	RA351,355,472
S-7257	597244C91	GEAR SET 6.57	RA351,355,472
S-7259	597248C91	GEAR SET 3.73	RA474
S-7260	597249C91	GEAR SET 3.91	RA474
S-7261	597250C91	GEAR SET 4.10	RA474
S-7262	597251C91	GEAR SET 4.44	RA474
S-7263	597252C91	GEAR SET 4.78	RA474
S-7264	597253C91	GEAR SET 5.37	RA474
S-7265	597254C91	GEAR SET 6.14	RA474
S-7266	597255C91	GEAR SET 6.57	RA474
S-7267	597256C91	GEAR SET 7.17	RA474
S-2168	891081R92	GEAR SET 4.10	RA351,355
S-C435	1665337C91	GEAR SET 3.42 FWD	N340,X380,N400
S-A346	1665338C91	GEAR SET 3.54 FWD	N340,X380,N400
S-A347	1665339C91	GEAR SET 3.73 FWD	N340,X380,N400
S-A348	1665340C91	GEAR SET 3.91 FWD	N340,X380,N400
S-A349	1665341C91	GEAR SET 4.10 FWD	N340,X380,N400
S-F038	1665344C91	GEAR SET 4.78 FWD	N340,X380,N400
S-F039	1665349C91	GEAR SET 5.63 FWD	N340,X380,N400
S-F041	1665350C91	GEAR SET 6.14 FWD	N340,X380,N400
S-A833	1665357C91	GEAR SET 3.54 RR	N175,N190,N210,N340,N380,N400
S-A992	1665358C91	GEAR SET 3.73 RR	N175,N190,N210,N340,N380,N400
S-A350	1665359C91	GEAR SET 3.91 RR	N175,N190,N210,N340,N380,N400
S-A351	1665360C91	GEAR SET 4.10 RR	N175,N190,N210,N340,N380,N400
S-A352	1665361C91	GEAR SET 4.44 RR	N175,N190,N210,N340,N380,N400
S-9447	1665363C91	GEAR SET 4.78 RR	N175,N190,N210,N340,X380,N400
S-F075	1665365C91	GEAR SET 5.11 RR	N175,N190,N210,N340,X380,N400
S-A353	1665367C91	GEAR SET 5.38 RR	N175,N190,N210,N340,N380,N400
S-F076	1665368C91	GEAR SET 5.63 RR	N175,N190,N210,N340,N380,N400
S-A354	1665369C91	GEAR SET 6.14 RR	N175,N190,N210,N340,N380,N400
S-F040	1665371C91	GEAR SET 7.17 RR	N175,N190,N210,N340,N380,N400

LATEST ADDITIONS TO OUR CATALOG

EXCEPT WHERE SPECIFIED, ALL PARTS SUPPLIED ARE S&S/NEWSTAR. USE OF OTHER MANUFACTURERS' NAMES, PART NUMBERS, OR TRADEMARKS ARE FOR INFORMATIONAL AND IDENTIFICATION PURPOSES ONLY.



REPLACEMENT GEARS AND PARTS

APPLICATION: INTERNATIONAL TRUCK AXLES

NEWSTAR NUMBER	REPLACEMENT FOR PART NUMBER	DESCRIPTION	APPLICATION - MODEL
S-6652	ST679	BEARING	RA351,355,F
S-13401	19415R1	ROLL PIN	N400
S-5100	19499R1	NUT	RA351,355,F
S-5100	26244R1	NUT	RA351,355,F
S-4353	27857R1	CASE BOLT	RA472,474,F
S-4970	68934R2	SIDE GEAR	RA39
S-4115	86233H	WASHER	RA29,30,39
S-3156	88015H	WASHER QTY PKG 4	RA30,351F,355F
S-5080	157490R1	RIVET	RA351,355,472,N400
S-4261	157494R1	WASHER	RA42,351,355
S-6359	157518R1	AXLE SHAFT	RA355
S-4194	157563R2	SIDE GEAR	RA355,472
S-3982	161042R3	PINION GEAR	RA474
S-5082	161060R1	RIVET	RA57,474
S-4018	161061R1	WASHER QTY PKG 12	RA472,474
S-4017	161064R2	WASHER	RA472,474
S-3980	161069R3	SPIDER	RA474
S-3981	161078R2	SIDE GEAR	RA57,474
S-3157	227279R1	WASHER	RA351,355,F
S-5110	227327R1	CASE BOLT	RA351,355,F
S-4569	227334R2	OUTPUT SHAFT	RA351,355,F
S-2043	227349R21	IDLER GEAR	RA351,355,F
S-5488	241278R1	WASHER QTY PKG 4	RA29,39
S-4998	241279R2	PINION GEAR	RA29,39
S-2042	243121R2	DRIVE GEAR	RA351,355
S-7208	336276R92	OIL SEAL	RA472,474,F
S-C319	344649C1	SPACER- 0.195"	REAR INPUT RA351F,355F
S-C320	344655C1	SPACER- 0.201"	RA351F,355F REAR INPUT
S-C321	344661C1	SPACER- 0.207"	REAR INPUT RA351F,355F
S-5173	371498C91	OIL SEAL	RA351,355,472,474,F
S-4700	388355C1	NUT	RA351,355,F
S-4234	396873C1	SHIM	RA472,474,F
S-2248	417834C1	HOUSING	RA351,355,F
S-3367	417854C1	SIDE GEAR	RA351,355,F
S-5848	421913C1	NUT	RA351,355,F
S-2607	436830C2	SPIDER	RA30,351F,355F
S-2351	436831C1	PINION GEAR	RA30,351F,355F
S-3929	440302C1	NUT	RA474, INPUT SHAFT ONLY
S-2044	441141C1	INPUT GEAR	RA351,355,F
S-7667	446839C1	GASKET MAKER	BLACK SILICONE
S-4894	455460C1	AXLE SHAFT	RA30
S-3331	455463C2	AXLE SHAFT	16220,16244
S-5050	463340C1	SIDE GEAR	RA29
S-3370	463346C1	WASHER	RA351,355,F
S-4533	463402C1	SIDE GEAR	RA472,474,F
S-4537	463404C93	BOTTOM CASE HALF	RA472,474,F
S-7241	463412C1	SPIDER	RA472,474,F
S-4236	463413C1	WASHER QTY PKG 4	RA472,474,F
S-4531	463414C1	SIDE GEAR	RA472,474,F
S-7243	463419C1	PINION GEAR	RA472,474,F
S-4577	463430C2	CLUTCH COLLAR	RA472,474,F
S-4582	464237C2	OUTPUT SHAFT	RA474,F
S-4583	464238C2	OUTPUT SHAFT	RA472,F
S-4908	464248C1	BEARING	RA472,474
S-3698	474015C1	HOUSING	RA351,355,F
S-4924	474517C2	GASKET ELIMINATOR	MULTIPLE APPLICATIONS

DIFFERENTIAL



LATEST ADDITIONS TO OUR CATALOG

EXCEPT WHERE SPECIFIED, ALL PARTS SUPPLIED ARE S&S/NEWSTAR. USE OF OTHER MANUFACTURERS' NAMES, PART NUMBERS, OR TRADEMARKS ARE FOR INFORMATIONAL AND IDENTIFICATION PURPOSES ONLY.

REPLACEMENT GEARS AND PARTS

APPLICATION: INTERNATIONAL TRUCK AXLES

NEW STAR NUMBER	REPLACEMENT FOR PART NUMBER	DESCRIPTION	APPLICATION - MODEL
S-7246	481107C91	IDLER GEAR	RA472,474,F
S-4541	481108C1	INPUT GEAR	RA472,474,F
S-3375	481119C2	HOUSING	RA472,474,F
S-7247	481811C1	RETAINER	RA472,474,F
S-16385	482040C1	SHIM .040"	RA472,474,F
S-16386	482041C1	SHIM .047"	RA472,474,F
S-4576	482763C1	DRIVE GEAR	RA474,F
S-4415	483442C1	DRIVE GEAR	RA472,F
S-3338	487526C1	INPUT GEAR	RA351,355,F
S-7248	492259C1	DRIVE GEAR	RA351,355,F
S-5117	493193C91	GEAR KIT	RA29
S-4660	493194C91	GEAR KIT	RA39
S-4952	493197C91	GEAR KIT	RA472
S-5348	493198C91	GEAR KIT	RA57,474
S-4812	493200C91	GEAR KIT	RA472,474,F
S-9635	493204C91	CASE ASSEMBLY	RA44,57,351,355,472 (3.74 THRU 4.44)
S-9636	493205C91	CASE ASSEMBLY	RA44,47,351,355,472 (4.78 THRU 8.17)
S-7597	493209C91	MATCHED CASE ASSY	RA472,474,F
S-13495	495024C1	RETAINING RING	N400
S-9574	499688C91	BEARING & SEAL KIT	RA57, 474 (RR) W/ INVOLUTE
S-7547	500016C1	AXLE GASKET QTY PKG 10	RA29,30,39,42,341, G175T,15201,16244
S-9575	504266C91	BEARING & SEAL KIT	RA30
S-4971	571347C1	AXLE SHAFT	RA29,30
S-9847	571348C2	AXLE SHAFT	F170S,G175T,155T,175S, J175S,N175,RA341
S-5892	571349C2	AXLE SHAFT	N175,N340,RA44,RA351,RA472
S-4972	571350C2	AXLE SHAFT	RA47,355,472
S-5136	571352C1	SIDE GEAR	RA29,39
S-4259	571353C1	SIDE GEAR	RA30
S-4257	571354C1	SIDE GEAR	RA47,472
S-4258	571355C1	SIDE GEAR	RA42
S-4256	571356C1	SIDE GEAR	RA57,474
S-4255	571357C1	SIDE GEAR	RA44
S-4974	578500C91	CASE ASSEMBLY	RA472,474,F
S-9511	578778C2	AXLE SHAFT	22065S,G190S,M220S,M190T,M210T,21121, 17421,17221,17202,17222,340SB,DT,DS341
S-D588	584278C1	SPRING	RA351/355/472/474 USED W/ SHIFT CYLINDERS
S-6660	585702C91	GEAR KIT	RA30
S-5143	585703C91	GEAR KIT	RA29,39
S-4709	585704C91	GEAR KIT	RA42
S-4732	585705C91	GEAR KIT	RA44,351
S-4876	585706C91	GEAR KIT	RA47,355,472,N400
S-5349	585707C91	GEAR KIT	RA57,474
S-5753	586049C1	MAGNETIC PLUG	RA29,30,39,42,44,47,57,351
S-A830	597105C91	GEAR KIT	M230T,G175S,M200S,220S,T,M190T,G175T,M210T
S-11764	597147C1	OIL SEAL	G155T,175S,T,M200S,210T,220S,T,230T
S-A343	597148C1	OIL SEAL	G155T,175T
S-7119	597155C1	PLANETARY PINION	M190T,220T
S-A344	597156C1	IDLER GEAR	G175T,M190T
S-10499	597157C91	CASE ASSEMBLY	G155T,175T,M190T
S-9762	597158C1	CASE BOLT	G155T,175T,M190T
S-9757	597168C1	CLUTCH PLATE	G155T,175T
S-7120	597171C1	SUN GEAR	M190T,220T
S-9173	597173C1	RETAINER, SUN GEAR	M190T,210T,220T,230T
S-15327	660433R1	SNAP RING	RA351F,355F,472F,474F
S-2048	864356R2	SPIDER	RA351,355,472

LATEST ADDITIONS TO OUR CATALOG

EXCEPT WHERE SPECIFIED, ALL PARTS SUPPLIED ARE S&S/NEWSTAR. USE OF OTHER MANUFACTURERS' NAMES, PART NUMBERS, OR TRADEMARKS ARE FOR INFORMATIONAL AND IDENTIFICATION PURPOSES ONLY.



REPLACEMENT GEARS AND PARTS

APPLICATION: INTERNATIONAL TRUCK AXLES

NEW STAR NUMBER	REPLACEMENT FOR PART NUMBER	DESCRIPTION	APPLICATION - MODEL
S-4262	864357R2	PINION GEAR	RA351,355,472
S-7268	864360R1	WASHER QTY PKG 12	RA351,355,472,F
S-7548	895478R2	AXLE GASKET QTY PKG 10	RA351R
S-7549	895493R2	AXLE GASKET QTY PKG 10	RA47,57,355,472,474
S-4974	1651264C91	CASE ASSEMBLY	RA472,474,F
S-4812	1651265C91	GEAR KIT	RA472,474,F
S-5117	1651267C91	GEAR KIT	RA29
S-4660	1651268C91	GEAR KIT	RA39
S-4952	1651271C91	GEAR KIT	RA472
S-5348	1651272C91	GEAR KIT	RA57,474
S-6660	1651273C91	GEAR KIT	RA30
S-5143	1651274C91	GEAR KIT	RA29,39
S-4709	1651275C91	GEAR KIT	RA42
S-4732	1651276C91	GEAR KIT	RA44,351
S-4876	1651277C91	GEAR KIT	RA47,355,472
S-5349	1651278C91	GEAR KIT	RA57,474
S-7208	1651280C91	OIL SEAL	N340,N400,J340S,J380S,J400S,W460S
S-5478	1651281C91	OIL SEAL	RA42,44,47,57,351R,355R,472R,474R
S-9575	1651515C91	BEARING & SEAL KIT	RA30
S-9566	1651517C91	BEARING & SEAL KIT	RA42,44,351,355,472(RR)
S-9574	1651519C91	BEARING & SEAL KIT	RA57,474 (RR) W/ INVOLUTE
S-E247	1651826C1	SPACER- 0.910"	RA57,474
S-8753	1665300C1	SIDE GEAR	N340,X380,N400
S-8756	1665307C91	INTER DIFF. ASSY.	N340,X380,N400
S-A345	1665309C91	DRIVE GEAR HELICAL ASSY.	N340,400
S-D752	1665315C1	THRUST WASHER	N340,400
S-E248	1665324C1	SPACER	N340,400
S-A580	1665325C91	GEAR KIT	N340,N400
S-8752	1665326C1	INPUT SHAFT	N340,X380,N400
S-A364	1665327C91	CASE KIT	N340,400 (3.06 THRU 4.44)
S-A365	1665328C91	CASE KIT	N340,400 (4.56 THRU 6.04)
S-A469	1665329C91	BEARING & SEAL KIT	N400 REAR
S-8757	1665332C1	SHIFT COLLAR	N340,X380,N400
S-9893	1665333C91	BEARING & SEAL KIT	N340,400
S-D594	1665334C1	POWER DIVIDER SHAFT	N340,400
S-9275	1665379C91	OUTPUT SHAFT	N340,X380,N400
S-A712	1665380C1	HELICAL DRIVE GEAR	N340,400
S-A737	1691143C2	OIL SEAL	RA44,57,474R,N175,190, 210,N340,400RR
S-9496	1691153C91	RETAINER	N340,N400
S-C005	1692964C91	INPUT SHAFT	NEW NO. FOR 1665326C91
S-8450	1694741C1	DRIVE GEAR	RA472,LATE STYLE
S-9573	1695392C91	BEARING & SEAL KIT	RA474 W/ INVOLUTE
S-9720	1696471C1	PINION NUT	G175S,G190S,G155T,G175T,M200S, M230T
S-A796	1696472C1	NUT, IDLER GEAR	RA472,474,F
S-13453	1696474C1	PINION NUT	N400,RA44,47,57,351R,355R,472,474
S-B246	1696994C1	BOLT KIT	N175,190,210,J190S,210S,G175T,190T, 220T,J340S,380S,400S,RA472
S-12106	1697352C91	BOLT KIT	RA474
S-C389	PD472	POWER DIVIDER KIT	RA472 FWD
S-9564	RA192FA	BEARING & SEAL KIT	RA351,355
S-9565	RA192FB	BEARING & SEAL KIT	RA351,355 (LATE)
S-9566	RA192RB	BEARING & SEAL KIT	RA42,44,351,355,472(RR)
S-9572	RA200F	BEARING & SEAL KIT	RA472
S-D792	RA200FA	BEARING & SEAL KIT	RA472 W/ INVOLUTE
S-9573	RA201F	BEARING & SEAL KIT	RA474 W/ INVOLUTE
S-9574	RA201R	BEARING & SEAL KIT	RA57,474 (RR) W/ INVOLUTE

DIFFERENTIAL



LATEST ADDITIONS TO OUR CATALOG

EXCEPT WHERE SPECIFIED, ALL PARTS SUPPLIED ARE S&S/NEWSTAR. USE OF OTHER MANUFACTURERS' NAMES, PART NUMBERS, OR TRADEMARKS ARE FOR INFORMATIONAL AND IDENTIFICATION PURPOSES ONLY.

REPLACEMENT GEARS AND PARTS

APPLICATION: INTERNATIONAL TRUCK AXLES

NEW★STAR NUMBER	REPLACEMENT FOR PART NUMBER	DESCRIPTION	APPLICATION - MODEL
S-9575	RA202	BEARING & SEAL KIT	RA30
S-B009	RA213	BEARING & SEAL KIT	G160,F175,G175,185,190
S-9893	RA223F	BEARING & SEAL KIT	N400
S-A469	RA223R	BEARING & SEAL KIT	N400(RR)

POWER DIVIDER KIT

NEW★STAR NO. S-C389

REPLACEMENT FOR PART NUMBER: **PD472**

AXLE MODEL:

RA472

CONSISTS OF ONE EACH:

NEW★STAR NUMBER	REPLACEMENT FOR PART NUMBER:	
S-7246	481107C91	IDLER GEAR
S-4541	481108C91	DRIVE GEAR
S-4415	483442C1	PINION DRIVE GEAR



REPLACEMENT RING GEARS AND PINION SETS

APPLICATION: VARIOUS MACK AXLES



NEW★STAR NUMBER	REPLACEMENT FOR PART NUMBER	DESCRIPTION	TOOTH COUNT	APPLICATION	REPLACEMENT FOR PAJ/EXCEL NUMBER
S-10060	24-KH-11072	GEAR SET 3.86,4.17,4.42	14X17	CPD 93,113	7535
S-E589	24-KH-11073	GEAR SET FWD 3.86,4.17,4.42 (FINE SPLINE)	14X17	CRDPC 92, 112	7534
S-3994	24-KH-1850-B	GEAR SET FWD 3.65,3.87	16X17	CRDPC 92,112	7914
S-3997	24-KH-1851-A	GEAR SET RR 3.65,3.87	16X17	CRD 93,113	7915
S-8356	24-KH-1873	GEAR SET FWD 5.55,6.34,7.00,7.13	13X21	CRDPC 92,112	7866
S-8357	24-KH-1875	GEAR SET RR 5.55,6.34,7.00,7.13	13X21	CRD 93,113	7867
S-4130	24-KH-1901	GEAR SET RR 4.64,5.02,5.32,5.73	13X19	CRD 91,113	7865
S-4129	24-KH-1902	GEAR SET FWD 4.64,5.02,5.32,5.73	13X19	CRDPC 92,112	7864
S-3996	24-KH-1908	GEAR SET FWD 4.50,4.76,5.13	13X17	CRDPC 92,112	7850
S-3999	24-KH-1910	GEAR SET RR 4.50,4.76,5.13	13X17	CRD 93,113	7900
S-6037	24-KH-1915-A	GEAR SET RR 3.86,4.17,4.42	14X17	CRD 93,113	7540
S-6038	24-KH-1917	GEAR SET FWD 3.86,4.17,4.42	14X17	CRDPC 92,112	7530
S-6038	24-KH-1917-A	GEAR SET FWD 3.86,4.17,4.42	14X17	CRDPC 92,112	7530
S-6059	24-KH-1939	GEAR SET FWD 3.65,3.87 (FINE SPLINE)	16X17	CRDPC 92,112	7916
S-6060	24-KH-1940-A	GEAR SET FWD 4.64,5.02,5.32,5.73 (FINE SPLINE)	13X19	CRDPC 92,112	7906
S-D672	24-KH-1941	GEAR SET FWD 5.88,6.34,7.00,7.13	13X21	CRDPC 92,112	7868
S-3995	24-KH-1943-B	GEAR SET FWD 3.86,4.17,4.42 (FINE SPLINE)	14X17	CRDPC 92,112	7531
S-16111	24-KH-1947	GEAR SET FWD 4.50,4.76,5.13 (FINE SPLINE)	13X17	CRDPC 92,112	7851
S-D673	24-KH-1948	GEAR SET RR 5.88,6.34,7.00,7.13	13X21	CRD 93,113	7869
S-6061	24-KH-1953-A	GEAR SET RR 4.64,5.02,5.32,5.73 (FINE SPLINE)	13X19	CRD 93,113	7907
S-6061	24-KH-1953-B	GEAR SET RR 4.64,5.02,5.32,5.73 (FINE SPLINE)	13X19	CRD 93,113	7907
S-6062	24-KH-1955	GEAR SET RR 3.65,3.87 (FINE SPLINE)	16X17	CRD 93,113	7917
S-3998	24-KH-1956-A	GEAR SET RR 3.86,4.17,4.42 (FINE SPLINE)	14X17	CRD 93,113	7541

DIFFERENTIAL



LATEST ADDITIONS TO OUR CATALOG

EXCEPT WHERE SPECIFIED, ALL PARTS SUPPLIED ARE S&S/NEWSTAR. USE OF OTHER MANUFACTURERS' NAMES, PART NUMBERS, OR TRADEMARKS ARE FOR INFORMATIONAL AND IDENTIFICATION PURPOSES ONLY.

REPLACEMENT GEARS AND MISC. PARTS

APPLICATION: VARIOUS MACK AXLES

NEW STAR NUMBER	REPLACEMENT FOR PART NUMBER	DESCRIPTION	APPLICATION - MODEL	REPLACEMENT FOR PAI/EXCEL NUMBER
S-5257	3-AX-1803-X	PINION BOLT	CRDPC 92, 112, CRD 93, 113	6060
S-7621	21-AX-360	NUT QTY PKG 10 EA.	CRDPC 92, CRD 93	5977
S-A471	25-KH-21	DIFF. KIT	CRD 92, CRD 93	2155
S-5957	56-AX-415	O-RING QTY PKG 10 EA	CRD 92	3000
S-5955	56-AX-423	O-RING QTY PKG 10 EA	CRD 93	2990
S-5956	56-AX-432	O-RING QTY PKG 10 EA	CRDP 92	2500
S-4710	88-AX-319-P2	OIL SEAL	CRDPC 92, 112	7690
S-8603	88-AX-354-P2	OIL SEAL	CRD 93, 113	7740
S-8417	579-GB-41-E	GASKET W/ SILICONE	ALL MACK 6 CYL. ENGINES	8414
S-6071	267-KC-144-A	PINION NUT	CRDPC 92, 112 (COARSE SPLINE)	2240
S-7599	267-KC-214-P2	PINION NUT	CRDPC 92, 112 (FINE SPLINE)	2241
S-4001	32-KH-228-A	SPIDER	CRDPC 92	7910
S-3990	33-KH-263-A	PINION GEAR	CRD 92, 93	7460
S-7576	34-KH-242-A	SIDE GEAR	CRDPC 112	7440
S-7576	34-KH-242-C	SIDE GEAR	CRDPC 112	7440
S-4000	34-KH-244-A	SIDE GEAR	CRDPC 92	2431
S-4000	34-KH-244-C	SIDE GEAR	CRDPC 92	2431
S-4000	34-KH-261	SIDE GEAR	CRDPC 92	2431
S-3992	37-KH-27-A	WASHER-QTY PKG OF 4	CRDPC 92, 112, CRD 93, 113	3050
S-3992	37-KH-128-A	WASHER-QTY PKG OF 4	CRDPC 92, 112, CRD 93, 113	3050
S-3992	37-KH-210	WASHER-QTY PKG OF 4	CRDPC 92, 112, CRD 93, 113	3050
S-7637	38-KH-25-C	WASHER	CRDPC 92, 112, CRD 93, 113	3040
S-7637	38-KH-215	WASHER	CRDPC 92, 112, CRD 93, 113	3040
S-7637	38-KH-218-A	WASHER	CRDPC 92, 112, CRD 93, 113	3040
S-7637	38-KH-220	WASHER	CRDPC 92, 112, CRD 93, 113	3040
S-6030	53-KH-261-B	RETAINER	CRDPC 92, 112	7220
S-13794	56-KH-433-A	SPUR PINION-17 TEETH	CRDPC 92, 112, CRD 93, 113	7964
S-7577	56-KH-3134-AP1	SPUR PINION-13 TEETH	CRDPC 92, 112, CRD 93, 113	2260
S-7577	56-KH-3134-P2	SPUR PINION-13 TEETH	CRDPC 92, 112, CRD 93, 113	2260
S-7577	56-KH-3134-P3	SPUR PINION-13 TEETH	CRDPC 92, 112, CRD 93, 113	2260
S-8952	56-KH-3136-A	SPUR PINION-14 TEETH	CRDPC 92, 112, CRD 93, 113	6890
S-4008	56-KH-3137-P1	SPUR PINION-16 TEETH	CRDPC 92, 112, CRD 93, 113	7930
S-4008	56-KH-3137-P2	SPUR PINION-16 TEETH	CRDPC 92, 112, CRD 93, 113	7930
S-4008	56-KH-3137-P3	SPUR PINION-16 TEETH	CRDPC 92, 112, CRD 93, 113	7930
S-8183	56-KH-3154-P2	SPUR PINION-17 TEETH	CRDPC 92, 112, CRD 93, 113	7961
S-8183	56-KH-3154-P3	SPUR PINION-17 TEETH	CRDPC 92, 112, CRD 93, 113	7961
S-4010	61-KH-47-AP2	BULL GEAR-55 TEETH	CRDPC 92, 112, CRD 93, 113	7920
S-7578	61-KH-47-P4	BULL GEAR-51 TEETH	CRDPC 92, 112, CRD 93, 113 FOR RATIOS 3.65,4.17,4.50,5.02	2080
S-9420	61-KH-47-BP7 (61-KH-47-P8) (61-KH-47-AP7)	BULL GEAR-51 TEETH	CRDPC 92, 112, CRD 93, 113 FOR RATIOS 5.13,5.73,6.34,6.45, 7.49,8.24,9.02,9.15,9.59	6790
S-7634	61-KH-47-P10	BULL GEAR-54 TEETH	CRDP 92 FOR RATIOS 3.86,4.64,6.06	7971
S-7634	61-KH-47-P11	BULL GEAR-54 TEETH	CRDP 92 FOR RATIOS 3.86,4.64,6.06	7971
S-4002	90-KH-253-B	THRU SHAFT	CRDPC 92, 112	2300
S-9419	90-KH-411	THRU SHAFT	CRD 92, 112	2295
S-11922	97-KH-21	CLUTCH GEAR	CRDPC 92, 112	7841
S-7633	31-KN-44	OUTER CAM W/ LOCKOUT	CRDPC 92, 112	2381
S-3987	31-KN-47	OUTER CAM	CRDPC 92, 112 (FINE SPLINE)	2382
S-9247	31-KN-48	OUTER CAM W/ LOCKOUT	CRDPC 92, 112 (FINE SPLINE)	2383
S-3993	31-KN-355	OUTER CAM	CRDPC 92, 112	2380
S-3988	32-KN-38	INNER CAM	CRD 92, 93	2390
S-3988	32-KN-230-A	INNER CAM	CRD 92, 93	2390
S-4318	33-KN-381	OUTER CAGE	CRDPC 92, 112	2420

LATEST ADDITIONS TO OUR CATALOG

EXCEPT WHERE SPECIFIED, ALL PARTS SUPPLIED ARE S&S/NEWSTAR. USE OF OTHER MANUFACTURERS' NAMES, PART NUMBERS, OR TRADEMARKS ARE FOR INFORMATIONAL AND IDENTIFICATION PURPOSES ONLY.



REPLACEMENT GEARS AND MISC. PARTS

APPLICATION: VARIOUS MACK AXLES

NEW★STAR NUMBER	REPLACEMENT FOR PART NUMBER	DESCRIPTION	APPLICATION - MODEL	REPLACEMENT FOR PAI/EXCEL NUMBER
S-4006	33-KN-411	CAGE	CRDPC 92, 112 (FINE SPLINE)	2422
S-3989	30-KNA-12	WEDGE SET	CRD 92, 93	1230
S-9576	205-SP-71	BEARING & SEAL KIT	CRD 93, 113	7141
S-9577	205-SP-72	BEARING & SEAL KIT	CRDLP 92, CRDPC 112	7121
S-A470	_____	DIFF. KIT	CRDPC 112, 113	2156

DIFFERENTIAL

ARE YOU AWARE **NEW★STAR** NOW
OFFERS REBUILD KITS FOR MOST
POPULAR MERITOR WORLD AXLES?

SEE PAGES 118-119



REPLACEMENT AXLE SHAFTS

SUITABLE FOR ARVIN MERITOR, DANA®, DANA® (FORMERLY EATON), GM, FORD AND INTERNATIONAL TRUCK AXLES

NEW STAR NUMBER	REPLACEMENT FOR PART NUMBER	INDUSTRY NUMBER	APPLICATION	SPLINE/O.D.	LENGTH	T-TAPER/S-STRAIGHT NO. OF BOLT HOLES/SIZES
S-3330	38208	892	18120,18220,38D	16 - 2.125	39 3/4"	S 8 - 49/64"
S-6359	43981	983	18202,18222,RA192	20 - 2.093	39 5/8"	S 8 - 49/64"
S-6360	43982	989L	18202,18222,18322	20 - 2.093	42 1/16"	S 8 - 49/64"
S-1712	43983	989R	18202,18222,18322	20 - 2.093	37"	S 8 - 49/64"
S-6361	44006	984L	RA146,17202	16 - 1.980	43"	S 8 - 41/64"
S-6362	44007	984R	RA146,17202	16 - 1.980	38"	S 8 - 41/64"
S-3116	56980	749	34DS,17120,17220	16 - 1.975	40 3/4"	T12 - 17/32"
S-3330	56981	1052	38DP,RP,DS,RS	16 - 2.125	40 1/8"	S 8 - 49/64"
S-6371	58975	1053	16244	16 - 1.875	38 7/16"	T 8 - 33/64"
S-6377	62165	1049	17200,220,34DS	16 - 1.980	41 5/16"	T12 - 9/16"
S-6378	62166	1087	38D,18120,220	16 - 2.125	41 5/16"	T 8 - 41/64"
S-3330	64130	1063	38DP,38RP,38DS,38RS	16 - 2.120	40 1/8"	S 8 - 49/64"
S-6381	65360	1054	15200	19 - 1.770	38 3/16"	T 8 - 29/64"
S-6393	79005	1128	18,23,26,44,480	22 - 2.298	40 7/8"	S 8 - 41/64"
S-6378	81216	1083	18220,38RS	16 - 2.125	41 11/16"	T 8 - 41/64"
S-6980	110880	1137	15200	34 - 1.750	38 3/16"	T 8 - 29/64"
S-6472	110882	1134	34D,D340,341,17221	39 - 2.000	40 7/8"	T12 - 17/32"
S-6473	110884	1135	18,22,38,380,381	41 - 2.100	41 1/2"	T 8 - 41/64"
S-A748	110885	1136	23,26,H172	36 - 2.312	41 1/2"	T 8 - 41/64"
S-6474	110886	1140	17220,34,340,341	39 - 2.000	41 5/16"	T12 - 17/32"
S-8436	110888	—	DS,RS-381,402	41 - 2.100	41 5/16"	S 8 - 41/64"
S-F124	110889	1215	DS,RS-461	36 - 2.062	40 7/8"	S 8 - 33/64"
S-F125	111544	1141	15040S,T	34 - 1.850	38 3/4"	T 8 - 33/64"
S-9733	113645	1139	16620	36 - 1.850	40 9/16"	T12 - 17/32"
S-6981	118866	1167	13020,15020	34 - 1.750	38 1/4"	T 8 - 5/8"
S-9511	119594	1150	17220,341	39 - 2.000	41"	S 8 - 41/64"
S-8903	119595	1151	18220,22220,381	41 - 2.100	40 3/4"	S 8 - 49/64"
S-E783	119927	—	19055S-D	39 - 2.000	40 29/32"	T 12 - 3/4"
S-B425	127138	—	DS461P	—	41"	—
S-D884	127437	1226	DS404,RS404	41 - 2.100	38 31/32"	S 8 - 5/8"
S-D885	127438	1227	DS404,RS404	41 - 2.100	43 5/16"	S 8 - 5/8"
S-E633	128516	—	DS454,RS404,22060S	41 - 2.100	38 31/32"	T 8 - .948"
S-9218	210512	1202	19050T-S	36 - 1.840	41 9/32"	T 12 - 17/32"
S-8892	E77Z-4234-B	5435B	8.8" FORD	31 - 1 21/64	32"	S 5 - 5/8"
S-8894	14071750	PA5383	8.8" GM	30 - 1 19/64	30 1/2"	S 6 - 7/16"
S-A366	14071751	PA5569	8.8" GM	30 - 1 19/64	31 5/16"	S 5 - 7/16"
S-8896	26010416	PA5532	8.5" GM	30 - 1 19/94	32"	S 6 - 5/8"
S-B824	26013313	PA5561	8.5" GM	1.274	33 5/16"	S 5 - 5/8"
S-9830	26013882	PA5566	7.625" GM - 4WD	28 - 1 3/16	28	S 5 - 1/2"
S-6359	157518R2	983	RA355	20 - 2.093	39 5/8"	S 8 - 49/64"
S-4894	455460C1	1103	RA30	16 - 1.750	38 5/8"	S 8 - 37/64"
S-3331	455463C2	1100	16220,244	16 - 1.875	39 1/2"	S 8 - 37/64"
S-4971	571347C1	1163	RA29,30	36 - 1.850	39 1/8"	S 8 - 37/64"
S-9847	571348C2	1154	G155T,175T, N175,J175S,F170S,RA341	36 - 1.850	39 7/8"	S 8 - 37/64"
S-5892	571349C2	1161	N175,340,RA44,351,472	39 - 2	40 5/8"	S 8 - 41/64"
S-4972	571350C2	1156	RA47,355,472	41 - 2.100	40 3/16"	S 8 - 49/64"
S-A704	577504C1	1152L	18202,22,302,22	41 - 2.125	42 3/4"	S 8 - 49/64"
S-A705	577505C1	1152R	18202,22,302,22	41 - 2.125	37 3/4"	S 8 - 49/64"
S-8903	577506C1	1151	18220,22220,381	41 - 2.100	40 3/4"	S 8 - 49/64"
S-9511	578778C1	1150	17220,341	39 - 2.000	41"	S 8 - 41/64"
S-6968	3202-R-3268	1043	SQHD	22 - 2.125	40 9/16"	T 8 - 41/64"
S-10183	3202-A-3459	1042	SSH D	23 - 2.250	38 7/16"	T 8 - 47/64"
S-6970	3202-X-3508	1037	R170	24 - 2.375	40 11/16"	T 8 - 41/64"
S-6972	3202-L-6356	1101S	SQHP	41 - 2.100	38 3/8"	T 8 - 41/64"

LATEST ADDITIONS TO OUR CATALOG

EXCEPT WHERE SPECIFIED, ALL PARTS SUPPLIED ARE S&S/NEWSTAR. USE OF OTHER MANUFACTURERS' NAMES, PART NUMBERS, OR TRADEMARKS ARE FOR INFORMATIONAL AND IDENTIFICATION PURPOSES ONLY.



REPLACEMENT AXLE SHAFTS

SUITABLE FOR ARVIN MERITOR, DANA®, DANA® (FORMERLY EATON), GM, FORD AND INTERNATIONAL TRUCK AXLES

NEW STAR NUMBER	REPLACEMENT FOR PART NUMBER	INDUSTRY NUMBER	APPLICATION	SPLINE/O.D.	LENGTH	T-TAPER/S-STRAIGHT NO. OF BOLT HOLES/SIZES
S-6973	3202-N-6358	1101L	SQHP	41 - 2.100	42 3/8"	T 8 - 41/64"
S-6974	3202-X-6472	1028	SLHD	21 - 2.000	40 5/16"	T 12 - 33/64"
S-6975	3202-L-6564	1024	SQHD	22 - 2.125	39 3/16"	S 8 - 49/64"
S-6977	3202-T-6728	1126L	SSHD	24 - 2.370	43 3/16"	T 8 - 41/64"
S-6978	3202-U-6729	1126S	SSHD	24 - 2.370	38"	T 8 - 41/64"
S-6980	3202-P-7816	1110	F106	34 - 1.750	38 3/8"	T 8 - 29/64"
S-D845	3202-U-7977	—	SSHD,RS-23-157, R255,U340	24 - 2.375	42 1/2"	S 8 - 25/32"
S-D846	3202-V-7978	—	SSHD,RS-23-157,R255,U340	24 - 2.375	37 21/64"	S 8 - 25/32"
S-6981	3202-Q-8389	1172	F106	34 - 1.750	38 1/4"	T 8 - 5/8"
S-12037	3202-H-8666	1187	RS-23-180,185,186	46 - 2.350	43"	T 8 - 47/64"
S-11747	3202-B-8816	1184	160,161 & 164	46 - 2.350	44 1/8"	T 8 - 47/64"
S-11916	3202-Q-8805	1183	23-160	46 - 2.350	37 5/16"	T 8 - 47/64"
SA738	3202-J-8902	1175R	RS-17-220	36 - 1.850	41 35/64"	T 12 - 17/32"
SA739	3202-L-8904	1175L	RS-17-220	36 - 1.850	40 9/32"	T 12 - 17/32"
S-9422	3202-W-8915	1180	21230	39 - 2	41"	T 8 - 41/64"
S-12038	3202-Y-8917	1188	RS-32-240	41 - 2.100	41 1/8"	T 8 - 47/64"
S-9422	3202-Q-8935	1181	21230	39 - 2	40 5/16"	T 8 - 41/64"
S-D890	3202-E-9001	1174R	RS-13-120,15-120, 15-125,15-210	34 - 1.750	38 39/64"	T 8 - 33/64"
S-D889	3202-F-9002	1174L	RS-13-120,15-120, 15-125,15-210	34 - 1.750	40 7/16"	T 8 - 33/64"
S-D888	3202-F-9340	1191	20-145,21-145	41 - 2.100	37 1/4"	T 8 - 41/64"
S-D887	3202-G-9341	1192	20-145,21-145	41 - 2.100	43 1/4"	T 8 - 41/64"
S-D886	3202-H-9342	1190	RD-RP-20-145,22-145, RR-20-145,22	41 - 2.100	43 1/4"	T 8 - 41/64"
S-11848	3202-S-9483	—	RS-20-145	41 - 2.100	38.04"	S 8 - 41/64"
S-9831	43651-1	—	80	37 - 1.60	37 5/8"	S 8 - 5/8"

DIFFERENTIAL



REPLACEMENT DIFFERENTIAL BEARING, SEAL & GASKET KITS

NEW STAR NUMBER	REPLACEMENT FOR INDUSTRY NUMBER	REPLACEMENT FOR PART NUMBER	DESCRIPTION
S-9552	RA1	99051	DANA@(FORMERLY EATON)34,38,42 RP,RS,RT340,380,400,17,18 SERIES
S-9553	RA1A	99041	DANA@(FORMERLY EATON) 34,38,RP,RT W/ CONICAL CARRIER
S-9706	RA9R	KIT-4025	MERITOR LHR,QHR 1 3/16" PINION W/ RATIOS ABOVE 4.63
S-9705	RA9RB	KIT-4010	MERITOR LHR,QHR 1 3/8" PINION W/ RATIOS ABOVE 4.63
		KIT-1915	
S-9779	RA9RC	KIT-1916	MERITOR LHR,QHR W/ RATIOS 4.63 & BELOW
		KIT-4005	W/ 1 3/8" PINION
S-9554	RA18E	99096	DANA@(FORMERLY EATON) 44RS,23130,23131
S-9555	RA23D	99050	DANA@(FORMERLY EATON) 16244,247,344,16220 W/ 15 1/2" RING GEAR
S-9556	RA24	99048	15200-1, 15300-1
S-9557	RA50	KIT-1924	MERITOR R170,SW170
		KIT-4110	
S-9558	RA64FD	99044	DANA@(FORMERLY EATON) 34,38DS, W/ CONICAL CARRIER
S-9559	RA72A	107670	DANA@(FORMERLY EATON) 44RP,RT,19-220,221,RP,RT440,460,480
S-9560	RA170	8873475	GM T170 ALL, 150 PRIOR TO 1983
S-9561	RA172FB	KIT-1923	MERITOR,SSH D W/ INVOLUTE
		KIT-4080	
S-9562	RA172R	KIT-1922	MERITOR,SHR,R SERIES,PR
		KIT-4105	
S-9563	RA191R	450083C93	F155S, 170S
S-9564	RA192FA	————	INTERNATIONAL RA351,355
S-9565	RA192FB	1651522C91	INTERNATIONAL RA351,355 (LATE)
S-9566	RA192RB	1651517C91	INTERNATIONAL RA42,44,351,355,472 (RR)
S-9567	RA193	99045	DANA@(FORMERLY EATON) DP,DS,DT 340,380,400
S-9568	RA194RA	KIT-1976	MERITOR,SQAR W/ 2"-39 SPLINE
		KIT-4045	
S-9569	RA194RB	KIT-4065	MERITOR,SLR,SQR
S-9570	RA194F	KIT-1912	MERITOR,SQHP,SL,SQ100
		KIT-4035	
S-9571	RA196	114394	DANA@(FORMERLY EATON) DS,341,381,381P,401P
S-9572	RA200F	472KS113	INTERNATIONAL RA472 W/ INVOLUTE
S-D792	RA200FA	————	RA472 W/ INVOLUTE SPLINES-LATE DESIGN
S-9573	RA201F	1695392C91	INTERNATIONAL RA474 W/ INVOLUTE
S-9574	RA201R	499688C91	INTERNATIONAL RA57,474 (RR) W/ INVOLUTE
S-9575	RA202	504266C91	INTERNATIONAL RA30
S-9576	RA205	205-SP-71	MACK CRD93,113
S-9577	RA206	205-SP-72	MACK CRDLP92,CRDPC,112
		205-SP-73	
S-9755	RA207	115125	DANA@(FORMERLY EATON) DP,DT341,381P,401P,402P,451P
S-B069	RA208	118109	DANA@(FORMERLY EATON) DS440P,460P,461P,521P,581P
S-A087	RA210	————	DANA@(FORMERLY EATON) DP440P,DT440P,DT460P,DP480P
S-B008	RA211F	————	DANA@ DS,DT461
S-9578	RA217F	KIT-4395	MERITOR RD,RP-17-145,20-145,22-145,34-145,40-145,44-145
S-A574	RA217R	KIT-4400	MERITOR RR-17-145,20-145,22-145,RS-21-145,RT-34-145,40-145,44-145
S-9839	RA218	KIT-4340	MERITOR RS-13-120,15-120
S-C672	RA219R	————	MERITOR RP,RT461,521,601
S-9579	RA222F	211222	DANA@(FORMERLY EATON) DS341,402,451 AFTER 4/6/89
S-9580	RA222R	211223	DANA@(FORMERLY EATON) RS341,402,451 AFTER 4/6/89
S-9893	RA223F	1665-333-C91	INTERNATIONAL N400
S-A469	RA223R	1665-329-C91	INTERNATIONAL N400 REAR
S-A575	RA224	————	MERITOR RR-20-145,RS-21-145,RT-40-145
S-9530	RA303	————	CHRYSLER 8.25",8.375"
S-9531	RA304	————	CHRYSLER 9.25"
S-9533	RA311	————	FORD 8.8"
S-D585	RA311F	————	FORD 8.8" FRONT-1997 AND LATER
S-9537	RA314	————	FORD 10.25"
S-9538	RA315	————	FORD 7.5"
S-D582	RA316	————	FORD 9.75" 1997 AND LATER

LATEST ADDITIONS TO OUR CATALOG

EXCEPT WHERE SPECIFIED, ALL PARTS SUPPLIED ARE S&S/NEWSTAR. USE OF OTHER MANUFACTURERS' NAMES, PART NUMBERS, OR TRADEMARKS ARE FOR INFORMATIONAL AND IDENTIFICATION PURPOSES ONLY.



REPLACEMENT DIFFERENTIAL BEARING, SEAL & GASKET KITS

NEW STAR NUMBER	REPLACEMENT FOR INDUSTRY NUMBER	REPLACEMENT FOR PART NUMBER	DESCRIPTION
S-D583	RA316A	—	FORD 9.75" 1999 AND LATER
S-D584	RA317	—	FORD 10.25" 1999 AND LATER
S-9540	RA321	—	GM 8.5"
S-D580	RA321CMK	—	GM 8.5"- 1999 AND LATER
S-9541	RA322	—	GM 8.875" LATE
S-9542	RA323	—	GM 8.875" EARLY
S-9543	RA324	—	GM 9.5"
S-9544	RA325	—	GM 10.5" EARLY
S-9545	RA325A	—	GM 10.5" LATE
S-9546	RA331	—	DANA® 60
S-9547	RA332	—	DANA® 70
S-9549	RA334	—	DANA® 30AF
S-D579	RA334TJ	—	DANA® MODEL 30-1997 AND LATER
S-D578	RA336	—	DANA® 50IFS-1980 AND LATER
S-C104	RA337	—	DANA® MODEL 80
S-B937	RA404F	216234	DANA®(FORMERLY EATON) DS404
S-B938	RA404R	216248	RS404
S-13939	RA411F	2500194C91	S400S
S-9582	RA900F	KIT-1913	MERITOR SLHD,SQHD
		KIT-4000	
S-C545	RA4390	KIT-4390	MERITOR RS-21-145,RT-40-145,44-145 AFTER 11/93
S-C546	RA4396	KIT-4396	RT-34-145, 40-145,44-145 AFTER 11/93
S-C547	RA4405	KIT-4405	RT-40-145,44-145 BEFORE 11/93
S-C548	RA4406	KIT-4406	RT-44-145 AFTER 11/93
S-C549	RA4415	KIT-4415	RS-23-160,23-161,26-160,46-160,52-160
S-F245	RA4420	KIT-4420	RT-46-160,52-160
S-C550	RA4423	KIT-4423	RT-46-140,52-160
S-C551	RA4426	KIT-4426	RS-23-160,23-161,26-160,RT-46-160,52-160
S-C552	RA4428	KIT-4428	RS-23-160,23-161,26-160,46-160,52-160
S-C553	RA4435	KIT-4435	RS-23-180,RT-48-180,52-180,58-180

DIFFERENTIAL



LATEST ADDITIONS TO OUR CATALOG

EXCEPT WHERE SPECIFIED, ALL PARTS SUPPLIED ARE S&S/NEWSTAR. USE OF OTHER MANUFACTURERS' NAMES, PART NUMBERS, OR TRADEMARKS ARE FOR INFORMATIONAL AND IDENTIFICATION PURPOSES ONLY.

REPLACEMENT DIFFERENTIAL MASTER BEARING, SEAL & GASKET KITS

REPLACEMENT INSTALLATION KITS CONSISTING OF ALL NEEDED BEARINGS, SHIMS, SEALS, SLEEVE, PINION NUT, BOLTS and GASKETS

NEW STAR NUMBER	REPLACEMENT NUMBER	REPLACEMENT FOR TIMKEN NUMBER	DESCRIPTION
S-8682	RA60	TS60R	60 DANA®
S-8683	RA70	TS70R	70 DANA®
S-8468	R9AXB	TF931R	9" FORD
S-8517	R88XB	TF88R	8.8" FORD
S-8475	R1025XB	TF1025R	10.25" FORD
S-8477	R625GXB	TGM75R	7.5" GM
S-8536	R10FRXB	TGM85R	8.5" GM
S-9232	R12RXB	TGM878R	8.8" GM
S-8535	R1495XB	TGM95R	9.5" GM
S-8495	R14XB	TGM105R	10.5" GM

LOOKING FOR WAYS TO PROMOTE PRODUCT?

NEW STAR OFFERS POINT OF PURCHASE (P.O.P) DISPLAYS AS SHOWN BELOW.

ASK YOUR SALES REP. FOR MORE INFORMATION.



BEARINGS

BEARINGS FOR LIGHT, MEDIUM & HEAVY DUTY TRANSMISSION & AXLE APPLICATIONS



CYLINDRICAL BEARING ASSEMBLIES

NEW★STAR NUMBER	REPLACEMENT FOR INDUSTRY NUMBER	REPLACEMENT FOR PART NUMBER
S-A001	118L	81548 5566504 1228-Z-260
S-12072	203FF	_____
S-12073	204FF	_____
S-12074	205FF	_____
S-5504	205SS	FP62052RS2 ST-518
S-F491	206FF	453879R91
S-13439	207	_____
S-D953	208L	_____
S-A004	211B	1228-V-204
S-D991	305SS	_____
S-A008	306DDL.5	_____
S-5940	306SS	ST-623 FP63062RS2
S-A012	306SSL.5	46AX534 , 46AX540
S-A013	308L	81519 81531
S-A014	308L1	_____
S-A015	N309L	227080
S-14073	1207L	92321
S-A016	N1211L	907993
S-A018	1212SLV	81504
S-A019	1308L	81031
S-13521	1309L	81022
S-A020	1310L	81052 1228-A-26
S-13221	1311L	81012
S-C034	1310SLV	81057
S-C100	7211HFL	550988
S-C101	7211HL	550989
S-C031	BS226539V	4304080
S-C030	BS500052V	4302712
S-C032	BS500192S	4304598
S-C102	F208323	550991
S-A022	MA1209EL	67-AX-291, 46584
S-11966	MG1212RUMW3	4301417

LATEST ADDITIONS TO OUR CATALOG

EXCEPT WHERE SPECIFIED, ALL PARTS SUPPLIED ARE S&S/NEWSTAR. USE OF OTHER MANUFACTURERS' NAMES, PART NUMBERS, OR TRADEMARKS ARE FOR INFORMATIONAL AND IDENTIFICATION PURPOSES ONLY.



BEARINGS

BEARINGS FOR LIGHT, MEDIUM & HEAVY DUTY TRANSMISSION & AXLE APPLICATIONS

CYLINDRICAL BEARING ASSEMBLIES

NEW STAR NUMBER	REPLACEMENT FOR INDUSTRY NUMBER	REPLACEMENT FOR PART NUMBER
S-A023	MSN1211REX	20899
S-A024	MR1307EL	8879
S-A025	MU1307TM	1228-F-136
S-A026	MUS1307TM	67-AX-210, 129175, 15828
S-A027	MU1308TV	14366
S-A791	MUSB7307UM	127051
S-A028	MU1308UM	1228-X-154
S-C032	MS1309GEXR	19551, 4304598
S-C026	MU61307GUM	4300828
S-C028	NP656227/NP896049	4301851
S-A031	RU1570UM	1228-F-552, 401HD108
S-A032	R1581TV	—
S-C632	RU9008UM	1228-B-1042

NEEDLE BEARING AND RACE ASSEMBLIES

NEW STAR NUMBER	REPLACEMENT FOR INDUSTRY NUMBER	REPLACEMENT FOR PART NUMBER
S-F218	F81205	550932
S-A037	FA35688	235382
		96828
S-9986	JB53851	497584C1
S-11979	Q8308	488847C1
S-11978	Q8371	497585C1
S-11980	RA53421	487869C1
S-A038	WJ162116	550886, 15045

TAPERED ROLLER BEARINGS

NEW STAR NUMBER	REPLACEMENT FOR INDUSTRY NUMBER	REPLACEMENT FOR PART NUMBER
S-A039	382A	142223
S-D993	382S	—
S-D994	387A	—
S-A040	387AS	9412408
S-11869	392	496535C1
S-D997	395	—
S-A041	453X	BB-1239-A
S-A042	469	EOTZ-1244-A
S-A043	493	9803, GGA-HA-101
S-E118	495	GGA-HB-101
S-A044	497	27813
S-16461	552A	1008912
S-13793	555S	GGA-HB-104
S-E272	576	—
S-D985	593	—
S-D985	594	—
S-E875	2065	581499

LATEST ADDITIONS TO OUR CATALOG

EXCEPT WHERE SPECIFIED, ALL PARTS SUPPLIED ARE S&S/NEWSTAR. USE OF OTHER MANUFACTURERS' NAMES, PART NUMBERS, OR TRADEMARKS ARE FOR INFORMATIONAL AND IDENTIFICATION PURPOSES ONLY.



BEARINGS

BEARINGS FOR LIGHT, MEDIUM & HEAVY DUTY TRANSMISSION & AXLE APPLICATIONS

TAPERED ROLLER BEARINGS

NEW STAR NUMBER	REPLACEMENT FOR INDUSTRY NUMBER	REPLACEMENT FOR PART NUMBER
S-D956	2135	7529018
S-D988	2759	—
S-D716	2924	706751
S-C526	3782	1008586
S-D995	3920	64AX13
S-D996	3925	—
S-4601	3979	91136 , 550612
S-D709	11520	—
S-D708	11590	—
S-E717	14131	—
S-E718	14276	—
S-D711	18520	—
S-D710	18590	—
S-D576	23100	705436
S-D577	23256	706845
S-F000	24721	—
S-E999	24780	—
S-13441	25520	550375
S-13442	25580	550182
S-10468	25821	550228
S-D712	25877	550183
S-D989	28521	—
S-D990	28580	237227
S-D715	28622	706873
S-D714	28682	705472
S-13520	28921	—
S-C594	28985	—
S-B848	29620	110811
S-A047	29630	127536
S-A048	29675	110812
S-F224	31594	710787
S-A049	31597	—
S-D718	33891	—
S-E038	45220	711123
S-16152	45285A	5557003
S-5237	47678	ST2112
S-A050	47820	550277
S-A051	47890	550273
S-A052	55200C	12496
S-11512	55212C	127535
S-A053	55437	12495
S-10518	56425	27817
S-10517	56650	27816
S-A054	72200C	45460, 119231
S-A055	72212C	14218
S-A650	72218C	85439
S-A056	72225C	—
S-6654	72487	14217, FP72487
S-11917	A-1400	1677057C91
S-E918	A2892	15260
S-13518	A3071	14367
S-F450	FWA1830	14287
S-A058	M88010	B7A-4616-A
S-A059	M88048	B7A-4621-A



LATEST ADDITIONS TO OUR CATALOG

EXCEPT WHERE SPECIFIED, ALL PARTS SUPPLIED ARE S&S/NEWSTAR. USE OF OTHER MANUFACTURERS' NAMES, PART NUMBERS, OR TRADEMARKS ARE FOR INFORMATIONAL AND IDENTIFICATION PURPOSES ONLY.

BEARINGS

BEARINGS FOR LIGHT, MEDIUM & HEAVY DUTY TRANSMISSION & AXLE APPLICATIONS

TAPERED ROLLER BEARINGS

NEW★STAR NUMBER	REPLACEMENT FOR INDUSTRY NUMBER	REPLACEMENT FOR PART NUMBER
S-A062	JLM104910	550899
S-A063	JLM104949	565905
S-F476	LM501310	64AX292
S-A064	LM501314	C6TZ-4222-A
S-A065	LM501349	B7A-4221-A
S-A066	JLM506811	—
S-A067	JLM506849A	—
S-A068	JM511910	98388, 550929
S-11492	JM511945	—
S-A069	JM511946	98387, 550930
S-13443	LM603011	—
S-A070	LM603012	D9AZ-4222-A
S-A071	LM603049	B7A-4221-B
S-A072	JLM710910	630695C1, 390HA100
S-A073	JLM710949C	630694C1, 390HB101
S-A074	H715311	FPH715311
S-A075	H715334	1228T592
S-A076	H715343	FPH715343
S-A077	JM716610	—
S-A078	JM716649	—
S-A079	M802011	C7AZ-4628-A, 1314774 C7AZ-4630-A, GGA-HA-109
S-A080	M802048	1314773 C7AZ-4630-A, GGA-HB-106
S-A081	HM803110	457337
S-D998	HM803146	—
S-A082	HM803149	9426883
S-D999	HM804810	—
S-A083	HM807010	35502, 64AX237, 401HA100
S-E001	HM807044	—
S-A084	HM807049	110846, 62AX439
S-E002	HM813810	113869
S-E003	HM813843	—
S-E008	HM88610	—
S-E009	HM88649	—
S-E010	HM89210	—
S-E011	HM89249	—
S-E012	HM89410	—
S-E013	HM89449	—

WHEEL BEARINGS

MULTIPLE MEDIUM AND HEAVY DUTY APPLICATIONS



THRU HARDENED STEEL - ALLOWS THE BEARING TO HAVE A BETTER LOAD CAPACITY AND IS LESS LIKELY TO FRACTURE UNDER SHOCK LOADS.

PHOSPHATE COATED CAGE - IS SPECIALLY ENGINEERED TO PREVENT CORROSION OF THE CAGE AND CONTAINS LUBRICATING PROPERTIES WHICH HELP PREVENT FRICTION BETWEEN THE CAGE AND ROLLERS.

SUPERIOR MICROFINISH ON ROLLERS AND RUNWAYS - REDUCES HEAT AND PROVIDES LONGER LIFE.

ISO 9001 CERTIFIED.

OEM APPROVED AND QUALITY CERTIFIED.

BEARINGS

NEW★STAR NUMBER	REPLACEMENT FOR PART NUMBER
S-A303	572
S-A304	580
S-A305	592A
S-A306	594A
S-A307	598A
S-A308	653
S-A309	663
S-C525	3720
S-C526	3782
S-D715	28622
S-D714	28682
S-A310	39520
S-A311	39590
S-E038	45220
S-A050	47820
S-A051	47890
S-A074	H715311
S-A075	H715334
S-A076	H715343
S-A312	HM212011
S-A313	HM212047
S-A314	HM212049
S-A315	HM218210
S-A316	HM218248
S-A317	HM518410
S-A318	HM518445

NEW★STAR NUMBER	REPLACEMENT FOR SET NUMBER
S-13216	SET 401 580/572
S-13217	SET 403 594A/592A
S-15371	SET 404 592A/598A
S-15372	SET 405 653/663
S-13218	SET 406 3782/3720
S-16170	SET 407 28622/28682
S-16171	SET 408 39500/39590
S-15375	SET 411 47620/47686
S-15376	SET 412 HM212011/HM212047
S-13219	SET 413 HM212049/HM212011
S-13220	SET 414 HM218248/HM218210
S-15377	SET 415 HM518410/HM518445
S-15378	SET 417 47820/47890
S-15379	SET 418 H715311/H715334
S-16550	SET 420 H715345/H715311

LATEST ADDITIONS TO OUR CATALOG

EXCEPT WHERE SPECIFIED, ALL PARTS SUPPLIED ARE S&S/NEWSTAR. USE OF OTHER MANUFACTURERS' NAMES, PART NUMBERS, OR TRADEMARKS ARE FOR INFORMATIONAL AND IDENTIFICATION PURPOSES ONLY.



REPLACEMENT OIL SEALS

APPLICATION: C/R AND NATIONAL



NEW STAR NUMBER	REPLACEMENT FOR INDUSTRY NUMBER	REPLACEMENT FOR PART NUMBER
S-9295	2043	19273
S-9296	2286	21955
S-9297	3604	18190
S-9298	3896	19314
S-5234	3905	—
	(TRIPLE LIP SEAL)	
S-9299	4278	18024
S-10379	4624V	—
S-E014	4876N	—
S-9300	7044NA	18264
S-9321	8460N	17190
S-9301	8610	15305
S-9302	8622	19277
S-9303	9316	18991
S-5366	9773	26373
S-4728	35009N	27452, 415960
S-7199	35949N	29273, 476500N
S-B435	4562V	30163
S-A941	4544V	—
S-A942	100494	—
S-D978	412015V	—
S-7205	415009	27470
S-7208	415013N	29925
S-9704	415027	6950
S-9222	415082	—
S-F307	415086	30055
S-8604	415146	415991N
S-8603	415272N	—
S-4710	415322N	27295, 417484, 475322
S-4366	415983N	37330
S-D545	417484	—
S-D979	455379V	—
S-A928	470625V	—
S-A936	471271	—
S-A720	473274N	4561V
	(TRIPLE LIP SEAL)	
S-7207	475003N	26220
S-8250	475012N	—
S-A630	476023N	29872, 415281, 417349
S-11764	477163N	070HH139
S-5478	710008	30148
S-A935	710211	—
S-5694	712937	29471
S-4528	713750	—
S-13369	714655	—
S-A947	KIT-5389	MERITOR TRANSMISSIONS

ADDITIONAL CATALOGS AVAILABLE

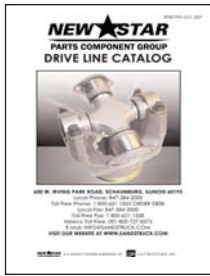

DRIVELINE COMPONENTS

INCLUDING: SLIP YOKES
END YOKES
CENTER BEARINGS
STRAP KITS
UNIVERSAL JOINTS



AIR / HYDRAULIC SYSTEMS COMPONENTS

INCLUDING: AIR BRAKE VALVES
SPRINGBRAKES
WHEEL END PARTS
CALIPERS
TRANSMISSION AIR VALVES
EMERGENCY BRAKE SHOES

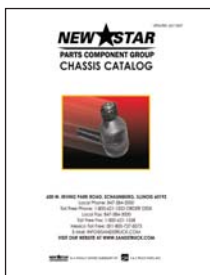

CHASSIS COMPONENTS

INCLUDING: TIE ROD ENDS
KING PIN KITS
DRAG LINKS
SPRING PINS
SHACKLES
BUSHINGS

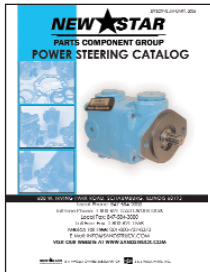

STEERING COMPONENTS

INCLUDING: POWER STEERING PUMPS
PUMP MASTER SEAL KITS
STEERING GEAR BOXES
GEARBOX MASTER SEAL KITS
GEARBOX SECTOR SHAFTS, BUSHINGS

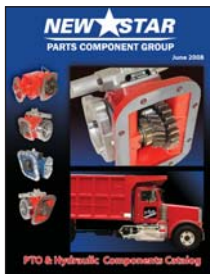

PTO COMPONENTS

INCLUDING: COMPLETE PTO ASSEMBLIES
DUMP PUMPS
PTO DRIVELINE COMPONENTS
CABLES
CONTROL VALVES

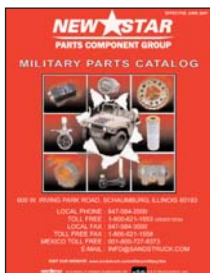

MILITARY COMPONENTS

INCLUDING: ELECTRICAL COMPONENTS
BRAKE COMPONENTS
CLUTCH COMPONENTS
EXHAUST COMPONENT
SUSPENSION COMPONENTS



S & S WARRANTY

All Drive Train Components covered in this catalog are warranted for one (1) year / 100,000 miles from installation, or 18 months after purchase from S & S Truck Parts, Inc., whichever comes first. We warrant all new parts against defective material or workmanship when such parts are used in appropriate applications. We will NOT extend this warranty to parts where failure or damage was caused by misapplication, accident, or abuse.

Unless otherwise stated, authorization from your salesperson is required to initiate any return for warranty. If our examination shows the parts to be defective, we will replace such parts free of charge. This warranty extends solely to replacement of defective parts; we disclaim liability for labor and/or special or consequential damages of any nature.

If it is necessary to return any parts under this warranty, the buyer agrees to wait for settlement of his claim before any deductions are made in payments to S & S. Any expenses incurred without the consent of S & S will be disallowed.

NEW STAR

PARTS COMPONENT GROUP

Established in 1954, S & S Truck Parts, Inc. is one of the largest independent suppliers of replacement truck parts in the world. Traditionally known as a drive train gear specialist, S&S has aggressively expanded its product range with the **NEW STAR** PARTS COMPONENT GROUP

Under the **NEW STAR** label, S&S supplies many of the fastest-moving parts and components in the following categories: Powertrain, Transmission, Differential, Chassis, Drive Line, Hydraulic, PTO, Power Steering, and Air Brake Parts.



S & S Truck Parts, Inc.

USA

Corporate Headquarters
600 W. Irving Park Road
Schaumburg, Illinois 60193
Local Phone : 847-584-2000
Toll Free: 1-800-621-1553 Order Desk
Local Fax : 847-584-3000
Toll Free Fax : 1-800-621-1558
Mexico Toll Free :001-800-727-8373

5320 Departure Drive
Raleigh, NC 27616
Toll Free: 1-800-334-7058
Toll Free Fax : 1-919-872-2836

Canada

6460 Kestrel Road
Mississauga, Ontario
L5T 1Z7
Local Phone : 905-564-7100
Toll Free: 1-800-363-4148
Local Fax : 905-564-3485

19272 - 96th Ave. Unit #15
Surrey, British Columbia
V4N 4C1
Local Phone : 604-882-2577
Toll Free: 1-800-665-4327
Local Fax : 604-882-3898

176 Creditstone Road, Unit 10
Concord, Ontario
L4K 4H7
Local Phone : 905-761-1399
Toll Free: 1-800-363-4148
Local Fax : 905-761-0698

16210 - 114 Avenue
Edmonton, Alberta
T5M 2Z5
Local Phone : 780-454-1010
Toll Free: 1-800-665-4327
Local Fax : 780-454-1555

Visit our website at www.sandstruck.com E-mail Address : info@sandstruck.com

AMERICAN EXPRESS, MASTERCARD AND VISA ACCEPTED



NEW STAR

IS A WHOLLY OWNED SUBSIDIARY OF S & S TRUCK PARTS, INC.