

FRAMES, FRAME KITS

14

SANTEE FRAMES



Santee 250 Chopper Frames with Single or Dual Downtubes

Santee® has built another beautiful frame in the latest style popularized by designers like Jesse James and Rick Doss. These frames are made from 1 3/8" diameter DOM tubing for strength, and have a 43 degree neck angle for the raked out look you're after. Use 6 degree triple trees to bring the rake and trail back to the happy spot. Santee's signature axle plates are more than strong enough to hold up the 250-series tire. The dual downtube frame looks large and in charge while the single downtube makes a bold statement. All frames come with 1" offset kit and axle. Frames have no tank mounts so you can use any of the popular designer tanks on the market today, and will accept all 5-and 6-speed transmissions. Most of the swingarm frames come with TÜV approval!

- 650052** Single downtube swingarm frame with 43° rake, 6" downtube stretch, 4" backbone stretch and no tank mounts (TÜV approved)..... \$2,999.99
- 650053** Dual downtube swingarm frame with 43° rake, 6" downtube stretch, 4" backbone stretch and no tank mounts (TÜV approved)..... \$2,999.99
- 650050** Single downtube rigid frame with 43° rake, 6" downtube stretch, 4" backbone stretch and no tank mounts \$2,199.99



Santee® 250 Frame Kits

Create the ultimate fat tired bike. Santee® frame kits come with everything you need to get your project started. They're designed to accept Avon's 'Super-Wide' 250 x 18" rear tire (CC #1012093) and may also be used with Metzler's 240 x 18" tire. They have all the features you've come to expect from Santee® including custom rear axle plates, boxed-in steering heads, and are designed to accept standard oil tanks. The engine and transmission mounts have a 3/4" offset that permits the use 230 to 250-series tires when using a 1 1/2"-wide rear belt. Frame kits include axle, primary spacer kit and tranny plate. Fender struts for rigid and swingarm frames are available separately.

250 Swingarm Frame Kits with TÜV

- 95112** Stock 30° rake, 0" downtube stretch, 0" backbone stretch, with 'flatside' tank mounts \$2,699.99
- 95123** 35° rake, 0" downtube stretch, 3" backbone stretch, with 'flatside' tank mounts \$2,799.99



Chica Style Gooseneck Rigid Frames by Santee®

These frames bring you the best of both worlds. Wide tail sections permit the use of today's wide series tires with full 1 1/2"-wide rear belts while the classic 38 degree Gooseneck provides old school chopper styling. Frames have fully machined axle plates, and accepts standard oil tanks.

- 170377** 38° rake frame with no tank mounts for up to 180-series tire \$1,799.99



Gooseneck frame as featured on Brass Knuckle!

FRAMES - FRAME KITS

Chica Style Gooseneck Swingarm Frames by Santee®

Frames accept any Big Twin engine (except Twin Cam 88° engines) and the wider-than-stock swingarms permit the use of up to 200-series tires with a 1 1/2"-wide rear belt. The 38 degree Gooseneck gives these frames a vintage chopper look.

- Smooth rear axle adjuster blocks
- Accept most Original Equipment or aftermarket accessories, and late 1987-up rear brake calipers and master cylinders
- Take early-style coil brackets (1948-early 1982)
- Require custom fender struts and 8 1/2"-wide rear fenders (not included)
- Constructed from 1 1/8"-diameter 1020 alloy steel tubing and use early bearing cups and bearings
- 4-speed or 5-speed transmissions may be installed with the appropriate mounting plate
- Include rear axle and swingarm pivot shaft with bearings

- 170379** 38° rake frame with no tank mounts for up to 180-series tire \$1,499.99
- 650054** 38° rake frame with no tank mounts for up to 200-series tire \$1,499.99

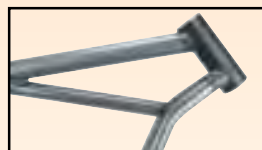

CUSTOM CHROME
WELD SERVICE



Santee® 200 Single Downtube Chopper Frames

These Santee single downtube frames feature the same quality, strength and great style, like our popular Santee 250 Chopper frames! Which gives us yet another opportunity to offer a unique custom frame that will satisfy your desire to customize. These frames are available in rigid or swingarm versions without tank mounts that provide you with endless opportunities to use any of the popular designer tanks we have to offer. Speaking of designer tanks, a rigid frame with tank mounts made exclusively for our Jesse James 'Villain' tank (CC #88120) is also available for another attractive custom idea!

- Made from 1 3/8"-diameter DOM tubing for maximum strength
- Accept up to 200-series tires for a brawny appearance
- Include 1" offset kit and axle for 5- or 6-speed transmissions

- 650048** Rigid frame with 40° rake, 6" downtube stretch, 4" backbone stretch and no tank mounts \$1,599.99

- 695040** Rigid frame with 40° rake, 6" downtube stretch, 4" backbone stretch and tank mounts for Jesse James 'Villain' tank \$1,599.99



CUSTOM CHROME
WELD SERVICE



650048



95400



95402



95401



95403

SANTEE



'D&D' 180 Frame Kits by Santee®

Get 'Down and Dirty' with these economically-priced frames by Santee®.

Chopper-Style

Ride high with these 34° rake frame kits. Add a set of apehangers and hit the road. The backbones are stretched 2 1/2", and the downtubes are stretched 3 3/4".

- 95400** Swingarm frame kit with TÜV \$1,249.99
- 95401** Rigid frame kit \$1,499.99

Stretched-Style

For those who like it a bit tamer, these frames feature a 35° rake and the backbones are stretched 3" with 0" stretch in the downtubes.

- 95402** Swingarm frame kit with TÜV \$1,249.99
- 95403** Rigid frame kit \$949.99



U.S. Patent #6,098,736

'Wide Drive' Frame and Swingarm Kits with TÜV

As Santee's engineers were developing the all-new Wide Drive swingarm system, they didn't neglect to address the needs of the committed ground-up builder. To create perhaps the ultimate foundation for a super-wide Softail®-based custom, they combined the popular Low Glide™ stock replacement frame (CC #95037) with the new Wide Drive swingarm kit. These frames accept up to a 200-series tire when built using 1 1/2"-wide belt drives, and accept most Big Twin engines (except Twin Cam 88° engines) including strokers. They also take any 1991 thru 1999 5-speed or 6-speed transmission for Softail® models and come complete with an offset transmission plate, alternator spacer, extended sprocket shaft kit, axle and pulley spacer, and a plastic splash guard.

95145 For drivetrain and components from 1991 thru 1999 Softail® models..... **\$1,699.99**



95039

Santee® Low Glide™ Frames and Swingarms

If you're after a stock look that's as easy to build as bolting on parts, choose our Low Glide™ frame. If you're after a more radical custom look with one of those really-wide rear tires, pick one of our Low Glide Custom™ frames.

Low Glide™ Stock Replacement Frame with TÜV

Stock-style frame kit accepts most Original Equipment or aftermarket accessories, with brackets and tabs for the coil, belt guard, late 1987 thru 1999 rear brake caliper and master cylinder, 'flatside' gas tanks, oil tank, shock absorbers and 1986 thru 1999 fender struts. There is also a mounting loop provided on the right front downtube for 1987 thru 1991 oil filter housings. Everything bolts in place like on stock frames. Frames have 1"-diameter 1020 mild steel tubing with a stock 32° rake, no stretch, and the swingarm is stock width with clearance for belt or chain drive. The steering head uses stock bearings and cups. With correct inner and outer primaries and transmission mounting plate, 4-speed, 5-speed or 6-speed transmissions can be installed. Include rear axle and swingarm pivot shaft with bearings.

95039 Frame and swingarm kit with TÜV **\$1,349.99**

95037 Replacement frame ONLY (no swingarm) **\$1,599.99**

Low Glide™ Stock Replacement Swingarm

May be used as a stock replacement for the Original Equipment unit. Fits all 5-speed Softail® models from 1986 thru 1999.

95044 Swingarm pivot bearing and retaining clip for all Softail® models from 1984 thru 1999 (repl. OEM 9076) **\$19.99**

17289 1/4"-offset driveline offset kit (permits the use of a 1/2"-wider rear tire) **\$85.99**

Accessories for Low Glide™ Frames

Here are some items to finish a hot custom bike.

Bearings and Cups

12263 Chrome bearing cups (pair) **\$25.99**

12264 Timken bearing (sold each) **\$9.99**

'Flatside' Gas Tanks

15298 5 gallon..... **\$199.99**

15294 6 gallon..... **\$179.99**

15600 5 gallon tanks with custom flush mount screw-top caps... **\$369.99**

25550 Gas tank mounting kit..... **\$49.99**



Santee® Disc Brake Fat Bob Rigid Frames for 4-Speed Belt Drive Big Twins

Wider, more versatile 4-speed rigid frames accept any Big Twin engine except Twin Cam 88° (including strokers and Evolution® motors) and use either chain or factory rear-belt final drive. They accept stock disc brake wheels from 1973 thru 1983 with the included chrome axle. Frames have a 33° neck rake angle (3° over stock) with a 2" front leg stretch. Oil tanks that fit include CC #'s 12576, 12600, 12601, 12603, 12581, 12582 and 12585.

Note: These frames will not accept Original Equipment-style rear fenders however, they may be used in conjunction with custom flat or Fat Bob fenders. Some of the oil tanks listed above require that a Mousetrap clutch actuator is used. The axle kit will work with these frames only and will not work as a stock replacement.

- 95009** Fat Bob rigid frame with mounts for 'flatside' Fat Bob tanks **\$1,149.99**



Santee® Juice/Disc Rigid Frames for 4-Speed Big Twins

Frames accept any Big Twin engine except Twin Cam 88° (including strokers and Evolution® motors) with chain final drives and 4-speed transmissions. They use any stock hydraulic drum or disc brake wheel setup from 1958 thru 1983 with the included chrome axle. Frames have a 33° neck rake angle (3° over stock) with a 2" front leg stretch. Oil tanks that fit include CC #'s 12576, 12600, 12601, 12603, 12581, 12582 and 12585. Frames include a Manufacturer's Statement of Origin (MSO) for registration.

Note: These frames will not accept Original Equipment-style rear fenders however, they may be used with custom flat or Fat Bob fenders. Axle kit works with this frame only.

- 08914** Frame with mounts for pre-1984 Fat Bob tanks **\$1,049.99**
- 95008** Frame with mounts for 'flatside' Fat Bob tanks **\$1,049.99**
- 08917** Frame with a 38° neck angle but without tank mounts.. **\$1,049.99**



Santee® Straight Leg Rigid Frames for 4-Speed Big Twins

These high-quality frames are available in two different versions that will accommodate any Big Twin engine except Twin Cam 88° including strokers or Evolution® motors, with 4-speed transmissions and chain final drives. All necks have a stock (30°) rake and no stretch in the front down tubes. Each frame requires the use of a special axle (see below). Every frame has Fat Bob tank mounts welded in place for pre-1984 tanks. Oil tanks that will fit these frames include CC #'s 12576, 12600, 12603, 08940, 12585, 12581, 12582 and 12583. Each frame includes a Manufacturer's Statement of Origin (MSO) for registration requirements.

- 08905** Mechanical brake frame (shown) **\$1,199.99**
- 08903** Disc brake frame **\$1,149.99**

SANTEE - PAUGHCO RIGID FRAMES

FRAMES - FRAME KITS



Santee® Wishbone Rigid Frames for 4-Speed Big Twins

High-quality frames accommodate any Big Twin engine except Twin Cam 88° including strokers and Evolution® motors, with 4-speed transmissions and chain final drives. Necks have a stock (30°) rake and no stretch in the front downtubes, and come with a chrome axle. Oil tanks for these frames include CC #s 12576, 12600, 12603, 08940, 12585, 12581, 12582 and 12583. Each frame includes a Manufacturer's Statement of Origin (MSO).

- 08897** Disc brake frame with mounts for pre-1984 Fat Bob tanks. \$1,099.99



Santee® Mechanical Brake Fat Bob Rigid Frame for Sportster® Models

Sleek-styled custom rigid frame for 1957 thru 1981 Sportster® engines and mechanical rear brakes (requires CC #95015 axle). Each frame features a 33° neck rake angle (3° over stock) and a 2 1/2" front leg stretch, which means the bike will handle and look good with a moderately longer front end. Includes a kickstand tab and rider's footpeg bar that can be welded wherever they work best. Oil tanks for this frame include CC #s 12572 and 12581. There is a Manufacturer's Statement of Origin (MSO) included with each frame.

- 95004** Complete frame kit. \$959.99

Chopper Style Sportster® Rigid Frames by Paughco

Designed to let you put any Sportster engine from 1957 to present in a cool lookin' chopper style frame! These "Chopper" style rigid frames feature 40 degree rake and 1 1/2" to 2 1/4" down tube stretch depending on model. Set up for final chain or belt drive and disc brakes. Accept Big Twin style 1" neck stems which let you choose from our wide variety of springers, girders or glide style front ends. No tank mounts so you can use any of our custom gas tanks. Frames accept up to a 130 series tire using chain drive or a conventional rear belt drive. Axle must be purchased separately. Must use #632247 oil tank with these frames and either #632249 battery box kit for kickstart applications or #632250 for electric start applications. Made in USA by Paughco.

- 632239** Chopper style rigid frame. XL's 1957-76 \$799.99
- 632240** Chopper style rigid frame. XL's 1977-85 \$829.99
- 632241** Chopper style rigid frame. XL's 1986 up \$829.99
- 632237** Axle for standard width Swedish & Chopper style XL frames. \$92.99

Oil Tanks for XL Rigid Frames by Paughco

This oil tank is for use with the "Swedish" & "Chopper" style rigid Sportster frames manufactured by Paughco. Drain plug sold separately. Made in USA by Paughco.

- 632247** Oil tank for use w/Paughco XL rigid frames. \$149.99
- 632248** Oil tank drain plug. \$4.99

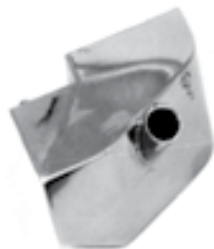



Bolt-On Hardtail for Sportster® Models

A bolt-on unit lengthens the wheelbase by 4 1/2" and lowers the bike 4". The oil tank to use with this frame is a CC #12599

08892 For Sportster® models with mechanical rear brakes from 1957 thru 1978..... **\$209.99**



Weld-On Hardtail for Big Twins

A quick and easy method of converting swingarm frames to rigid. It has the same wheelbase and ride height as stock. Oil tanks for this hardtail include CC #s 12601, 12571, 12603, 12600, 12581, 12582 and 12585. CC #12554 chain guard should also be used.

08893 Fits hydraulic drum brake 4-speed swingarm frames from 1958 thru 1972..... **\$199.99**



Weld-On Hardtail for Sportster® Models

Fits early Sportster® models with mechanical rear brakes. It forms an almost-perfect straight line with the frame backbone, and lengthens the motorcycle by 4" and lowers it 4". The oil tank to use with this frame is a CC #12599.

08889 Fits Sportster® models from 1957 thru 1978..... **\$209.99**



Küryakyn Swingarm Cover Kit with Lighted Phantom Covers

Includes four easy-to-install covers for the tubular sections of the swingarm, a pair of sleek, upper swingarm covers, and a pair of 'Phantom' axle covers dressed with rear facing red LEDs. The LEDs are single circuit, which means they function like a single filament bulb. They can be wired to operate as auxiliary running lights or turn signals or brake lights.

609981 Complete kit for Softail® Deuce™ models from 2000 thru 2005..... **\$195.99**

Note: Will only fit if Original Equipment 'Shotgun' exhaust has been replaced with a staggered dual or 2-into-1 exhaust system. Phantom covers are not DOT approved nor are they intended to replace stock turn signals or taillights.



Chrome Rear Frame Inserts for Softail® Models

Decorative, stamped-steel inserts are American-made and feature exceptional chrome-plating and a unique style all their own. They fit into the recesses in the rear frame sections of Softail® models and are held firmly in place with double-sided foam tape. Set of four pieces.

13600 Fit 5-speed Softail® models from 1986 thru 2006 (except Fat Boy® and Deuce™ models from 2000 to present)... **\$16.99**

- INDEX
- APPAREL
- SEATS & BAGS
- FOOT CONTROLS
- HAND CONTROLS
- LIGHTING
- ELECTRICAL
- EXHAUST
- INTAKE
- ENGINE
- GASKETS
- TRANNY & CLUTCH
- DRIVELINE
- WHEELS, TIRES & BRAKES
- FRAMES
- FORKS & SHOCKS
- SHEET-METAL
- GAUGES
- CHEMICALS
- GENERAL
- CROSS REFERENCE

FRAME - SWINGARM COVERS

Chrome Swingarm Pivot Bolt Covers from Designs by Novello

- CNC-Machined from 6061-T6 billet aluminum
- Chrome-plated finish
- Fits 2000-2007 Softail® models
- Sold in pairs

- 650890** Warrior pivot bolt covers \$64.99
650891 Smooth pivot bolt covers \$64.99
650892 Ball milled pivot bolt covers \$64.99



650890



650891



650892



Chrome Swingarm Pivot Bolt Covers for Softail® Models

These covers are held in place with set screws and look great when installed in conjunction with CC #28266 chrome rear frame covers. They fit all Softail® models from 1984 thru 1999 (except Fat Boy® and FLSTN models). Sold in pairs.

- 14317** Replaces OEM 43897-86 \$10.99



Chrome Swingarm Covers for Dyna Glide Models

Chrome-plated machined aluminum covers really add a nice custom touch to any Dyna Glide model from 1991 thru 2000. Made in USA.

- 47209** Left and right set \$75.99



Chrome Rear Frame Covers for Softail® Models

Dress up the rear section of your Softail®. Made of chrome plastic installs in minutes with silicone adhesive included (sold in pairs).

- 78054** Fits all Softail® models except Fat Boy® and FLSTN models from 1986 thru 1999 \$44.99

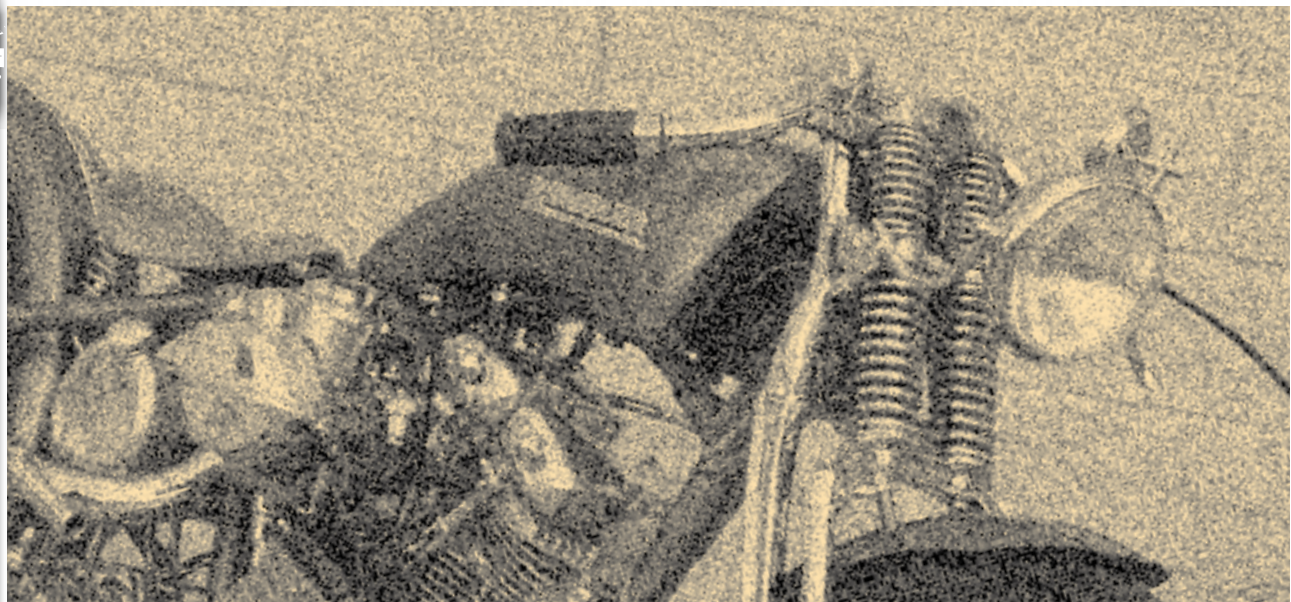

NEW



Flush Mounted Pivot Shaft for Late Softail® Models by Adjure

The design team at Adjure has come up with this new flush mounted stainless steel pivot shaft to give your bike a custom look without having to modify or machine your frame. Fits all Softail® models from 2000 thru 2007.

600095 Complete kit \$114.99



Stainless Steel Splash Guard by Pro-One™

The perfect replacement for the stock plastic part for a custom look.

65429 Fits 5-speed Softail® models from 1986 thru 1999 \$35.99



Chrome Swingarm Pivot Bolts for Softail® Models

Chrome hex head swingarm pivot bolts. Grade 8 bolts measure 3/4"-16 x 3"-long. Sold in pairs.

84378 Fit Softail® models from 1984 thru 1999 \$19.99

Swingarm Pivot Bolt Spacers for Softail® Models

Fit Softail® models from 1987 thru 1999.

84602 Pack of 10 \$24.99

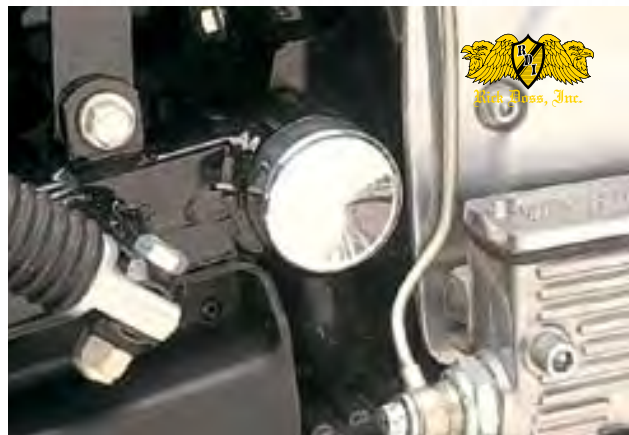

Chrome Pivot Bolt Cover for Late Sportster® Models

Fits over the exposed head of the swingarm pivot bolt on all Sportster® models from 1982 thru 2003. It features chrome-plated die-cast construction and is held firmly in place by a sockethead screw.

14318 Sold each \$5.99



95044



75497



75498



32905

Swingarm Pivot Components

Manufactured from high-quality materials for all factory and aftermarket swingarms. Sold each.

For Softail® Models from 1986 thru 1999

95044 Bearing and retaining clip (repl. OEM 9076) \$19.99
84379 Chrome sockethead pivot bolt set (repl. OEM 4961) \$24.99

For Dyna Glide Models

38022 Bushing kit for all models from 1991 thru 2006 \$94.99
38023 Left spacer ONLY (repl. OEMs 47495-90, 47496-90) \$18.99
38024 Right spacer ONLY (repl. OEM 47499-90) \$19.99
38025 Bushing ONLY (repl. OEM 47624-90A) \$11.99
38026 Washer ONLY (repl. OEM 47565-90) \$6.99
38027 Bearing ONLY (repl. OEM 47082-81) also fits Sportster® models from 1982 thru 2003 \$79.99
38028 Dust shield (repl. OEM 41585-90) \$5.99

For 5-Speed Rubber-Mount Models (except Dyna Glide Models)

75497 Rubber isolator ONLY for models from 1986 to present (repl. OEM 47564-86) \$52.99
75498 Rubber isolator ONLY for models from 1982 thru 1985 (repl. OEMs 47553-79A, 47564-82) \$99.99
38027 Bearing ONLY (repl. OEM 47082-81) \$79.99



Swingarm Repair Bolt

Repair stripped threads in Original Equipment cast frames with this self-tapping swingarm pivot bolt (+.025" oversize threads). Made in the USA.

31109 Fits 4-speed Big Twins from 1958 thru 1984 \$39.99

Note: Use hand tools ONLY to install.



Swingarm Bumpers

For stock replacement or custom applications. Replaces OEM 11451, and fit all Softail® models from 1985 thru 1999.

Original Equipment Bumpers

These are Original Equipment parts.

75190 Pack of 10 \$42.99
75191 Sold each \$5.99

Aftermarket Bumpers

695002 Sold each \$4.99

WIDE DRIVE KITS

NEW



'Brute 200' Wide Drive Kits for Touring Models by Reno Cycle Worx

This kit from Reno Cycle Worx, Ltd. drastically improves the looks, stability, performance, handling and overall "coolness" of your Bagger. They have engineered a better product than the other kits on the market. This kit does NOT require removal and replacement of the transmission main shaft nor does it require any primary spacing (maintain stock weight balance) making this truly a "bolt-on" wide tire kit. The bags remain in stock fender location so you could still split lanes with ease. Kits include: black powder coated swingarm, chrome inner primary, transmission pulley, rear pulley, final drive belt, rear fender, and all necessary brackets and hardware for an easy install.

- 610480** Fits FLHT/X, FLHR and FLTR models from 2007 to present \$3,495.00
- 610481** Fits FLHT/X, FLHR and FLTR models from 2002 thru 2006 \$3,495.00
- 610482** Fits FLHT/X, FLHR and FLTR models from 1980 thru 2001 \$3,495.00

Note: Installation of this kit will require the use of an Avon 200mm rear tire. Due to clearance issues Metzler 200mm tires will not work. Always make sure to check for adequate fender to tire clearance before operation.

FRAMES - FRAME KITS



NEW



RevTech® Chassis Stabilizer

Looking for a way to stop the wobbling, weaving, and rear steering on your Touring model? The RevTech® Chassis Stabilizer utilizes a swingarm pivot anchor to cure these problems. So you can feel confident leaning your Bagger into the corners with a RevTech® Chassis Stabilizer under your Bagger. Fits FLH/FLT models from 1995 to present.

- 668100** Satin Finish \$399.99
- 668101** Black Anodized Finish .. \$414.99



1/4" Offset Driveline Kit

In addition to a chrome primary spacer this kit includes a chrome transmission plate, bolts, O-rings, sprocket shaft spacer and rear pulley spacer. Permits the use of 1/2" wider tires in a stock chassis.

17289 Fits Softail® models from 1986 thru 1999 \$85.99



Engine-to-Primary Spacers

These aluminum spacers fit between the engine and inner primary to permit the use of the latest extra-wide rear tires with custom frame applications. from \$35.99 to \$99.99

Raw Finish	Chrome	
17287	17282	1/4" offset
n/a	17442	3/8" offset
17288	17283	1/2" offset
n/a	17443	3/4" offset
95148	17284	1" offset
17270	17529	1 1/2" offset
n/a	17444	45mm offset

Compensating Sprocket Assemblies

Replace your worn out Original Equipment unit with one of these complete assemblies.

Complete Assemblies

Each assembly includes shaft extension, cover with springs, sliding cam, engine nut and sprocket.

- 14241** 25-tooth for all Big Twin models from 1994 to present \$109.99
- 14249** Same as CC #14241 with 1" offset \$129.99
- 14235** 24-tooth for Softail models from 1991 thru 1993. \$109.99

14236 Same as CC #14235 with 1" offset \$129.99

14238 24-tooth for Softail® models from 1985 thru 1990. \$109.99

14231 24-tooth for 5-speed rubber-mount models from 1985 thru 1990 \$99.99

Cover Assemblies with Springs

Fit most models from 1985 to present.

14233 Fits 5-speed rubber-mount models from 1985 thru 1990 (repl. OEM 40267-85) \$41.99

14240 Fits Softail® models from 1985 thru 1990 (repl. OEM 40384-83A) \$35.99

14237 Fits all Big Twin models from 1991 thru 2005 (repl. OEM 40384-91) \$39.99

Compensating Sprocket Components

Restore your compensating sprocket to peak performance. Fit most Big Twins with primary chains from 1970 to present.

Sliding Cams for Big Twins

12222 Fits most models from 1970 thru 1983 (repl. OEM 40299-70) \$26.99

12764 Fits all models from 1985 thru 2005 (repl. OEM 40299-83A) \$25.99

Sprocket Nut for Big Twins from 1970 thru 1990

12112 Stock length-(repl. OEM 40392-70) \$12.99

14246 1/2" extended (repl. OEM 40392-70) \$19.99

14245 1" extended (repl. OEM 40392-70) \$19.99

Sprocket Nut for Big Twins from 1991 thru 2005

12078 Stock length (repl. OEM 40392-91) \$8.99

14248 1/2" extended (repl. OEM 40392-91) \$19.99

14247 1" extended (repl. OEM 40392-91) \$19.99

14771 1 1/2" extended (repl. OEM 40392-91) \$18.99

14198 45mm (1 3/4") extended \$17.99

Compensating Sprockets for Big Twins from Late 1970 thru 1986

12218 22-tooth (repl. OEM 40280-70) \$64.99

12232 23-tooth (repl. OEM 40282-70) \$57.99

12233 24-tooth (repl. OEM 40275-70) \$57.99

Compensating Sprockets for Big Twins from 1985 to Present

14234 24-tooth for Softail® models 1991 thru 1993 and 5-speed rubber-mount models from 1985 thru 1990 (repl. OEM 40269-85A) \$49.99

14242 25-tooth for all Big Twins from 1994 to present (repl. OEM 40308-94) \$49.99

Sprocket Shaft Extensions

For 4-speed Big Twins from late 1970 thru 1983, 5-speed Big Twins from 1980-early 1984 and Softail® models from 1984 thru 1990 (repl. OEM 40375-70).

20306 Stock length (imported) \$41.99

080075 1/2" extended (American-made) \$69.99

For Softail® models from 1991 thru 1999 and 5-speed rubber-mount Big Twin models from 1985 thru 1990 (repl. OEM 40266-85).

14232 Stock length (imported) \$28.99

14244 1/2" extended (imported) \$35.99

080076 1/2" extended (American-made) \$69.99

14243 1" extended (imported) \$35.99

95150 1" extended (American-made) \$74.99

14772 1 1/2" extended (imported) \$37.99

14196 45mm (1 3/4") extended (imported) \$39.99

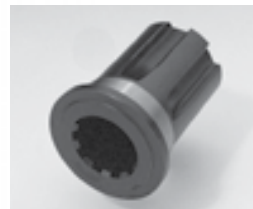
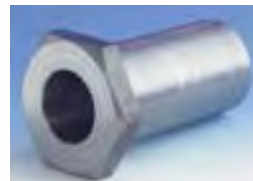

- INDEX
- APPAREL
- SEATS & BAGS
- FOOT CONTROLS
- HAND CONTROLS
- LIGHTING
- ELECTRICAL
- EXHAUST
- INTAKE
- ENGINE
- GASKETS
- TRANNY & CLUTCH
- DRIVELINE
- WHEELS, TIRES & BRAKES
- FRAMES
- FORKS & SHOCKS
- SHEET-METAL
- GAUGES
- CHEMICALS
- GENERAL
- CROSS REFERENCE

WIDE DRIVE CHASSIS ACCESSORIES



Offset Transmission Mounting Plates

These transmission mounting plates for Softail® models have a 1-inch offset to make assembly of Wide Drive swingarm or extra-wide rigid-framed customs a snap. The hot set up for building that extra-wide ride.

17285	Chrome	\$22.99
17286	Raw steel	\$18.99

Primary/Transmission Offset Kits by Primo

Now you can offset the transmission and primary allowing the use of a super-wide rear tire with these convenient offset kits!

- Kits use an extra length transmission mainshaft and sprocket shaft extension to move the primary drive components to the left either 25mm or 45mm
- Includes primary spacer ring, crankshaft extender and nut, extra length transmission mainshaft, extra length main drive 5th gear with needle bearing and seal, extra wide pulley spacer, extra length clutch pushrod, jackshaft extended (for 25mm kit only), front bearing support (for 45mm kit only) primary-to-transmission spacers and all necessary mounting hardware
- Wide swingarm and fender struts may be required for some applications
- Fit Evolution® and Twin Cam 88® Dyna Glide and Softail® models from 1991 thru 2005

667513	25mm (1") offset primary kit	\$759.99
667514	45mm (1.77") offset primary kit (includes front bearing support)	\$1,099.99



Doss Switch Mount Housing

This ignition key switch housing is intended to be welded to your frame.

62344	Fits custom applications	\$32.99
--------------	--------------------------------	----------------

Note: Must use CC #12286 ignition switch.



Primo Offset Front Pulley Inserts

Permits custom motorcycle builders the freedom to offset transmission allowing the use of wider rear wheel/tire assemblies. Offset inserts are available for Primo front pulleys. Special nuts and flanges (outside guide) are required. The 2.5" inserts fit Brute III front pulleys, the 3.5" inserts fit Brute IV pulleys. **From \$35.99 to \$99.99**

Inserts

Offset	2.5" dia.	3.5" dia.	Motor Nut
0.50"	86145	86150	86156
1.00"	86146	86151	86157
1.25"	86147	86152	86158
1.50"	86148	86153	86159
2.00"	n/a	86154	86160

86144	Outside guide for offset pulleys	\$14.99
86155	Special motor nut washer	\$4.99

Top Motor Mount Spacer Kits

Don't forget to space that top motor mount properly after you widened the driveline. Each of these kits includes the required hardware and the spacer listed below.

38061	Raw steel 3/8"-thick spacer kit	\$19.99
38062	Raw steel 5/8"-thick spacer kit	\$19.99
38060	Raw steel 1"-thick spacer kit (for 200 to 230-series tires)	\$19.99

FRAMES - FRAME KITS

NEW

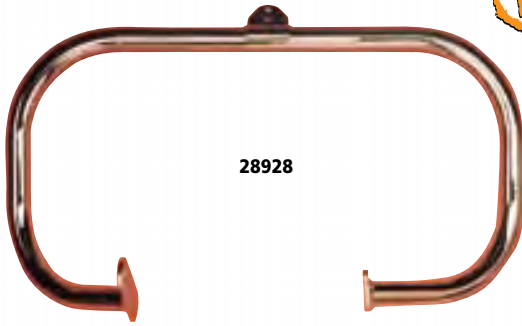

28928

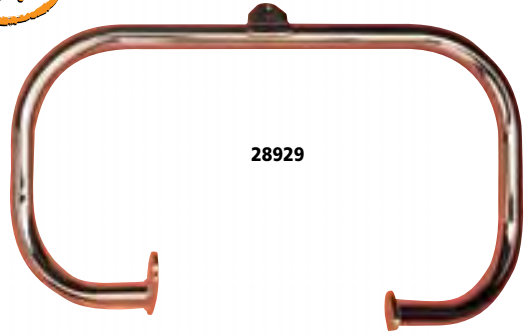

28929

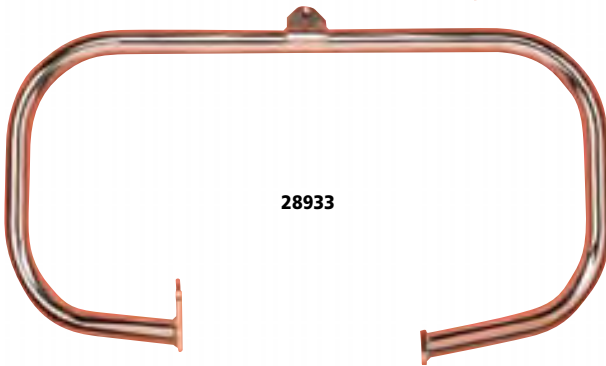

28933

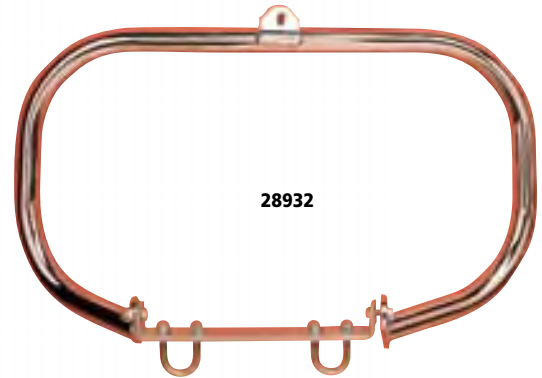

28932



28935



28934



28930

'OIS' Chrome Highway Bars

American-made reproductions of Original Equipment bars have flawless chrome-plating and are made from high-strength tubing with heavy-duty 1/4" steel plate mounts welded to the tubing to insure a perfect fit.

Front 1 1/4"-Diameter Highway Bars

- 609620** Fits FL Softail® models from 2000 to present\$149.99
- 28933** Fits FL Softail® models from 1986 thru 1999 (repl. OEM 49004-90).....\$145.99
- 609621** Fits FX Softail® models from 2000 to present.....\$179.99
- 28932** Fits FX Softail® models from 1984 thru 1999 and 4-speed FX models from 1972 thru 1986 (repl. OEM 49016-72D)\$155.99
- 609622** Fits Dyna Wide Glide® models from 1993 thru 2005\$209.99
- 609623** Fits all Dyna Glide models (except Dyna Wide Glide® models) from 1991 thru 2005\$169.99
- 609624** Fits all Sportster® models from late 1984 thru 2003.....\$189.99
- 28935** Fits Touring models from 1988 thru 1996 (repl. OEM 49184-88).....\$165.99
- 28929** Fits 4-speed FL models from late 1979 thru 1984 (repl. OEM 49040-79)\$109.99
- 28928** Fits 4-speed FL models with swingarm frames from 1958-early 1979 (repl. OEM 49038-58B).....\$124.99

Rear Highway Bars

- 28930** Fits 4-speed chain drive FL models from late 1967 thru 1984 (repl. OEM 49137-67B) 7/8" tubing.....\$129.99
- 28934** Fits Softail® models from 1986 thru 1999 (except 1990 thru 1999 FL Softail® models – see note) repl. OEM 49158-89B (1" tubing).....\$179.99

Note: 1990 thru 1999 FLTC models require the installation of CC #28927 Bracket Kit to replace the Original Equipment brackets which attach the saddlebag support frame to the footpeg bolt. Additionally, neither of CC's chrome toolbox kits may be installed because of contact with the saddlebag support frame.

Warning: These reproduction Highway Bars are for cosmetic use only and will not provide leg or vehicle protection in the event of a low-speed fall. They are not made nor intended to provide protection from bodily injury in a collision with an automobile or any other object.

HIGHWAY BARS

NEW

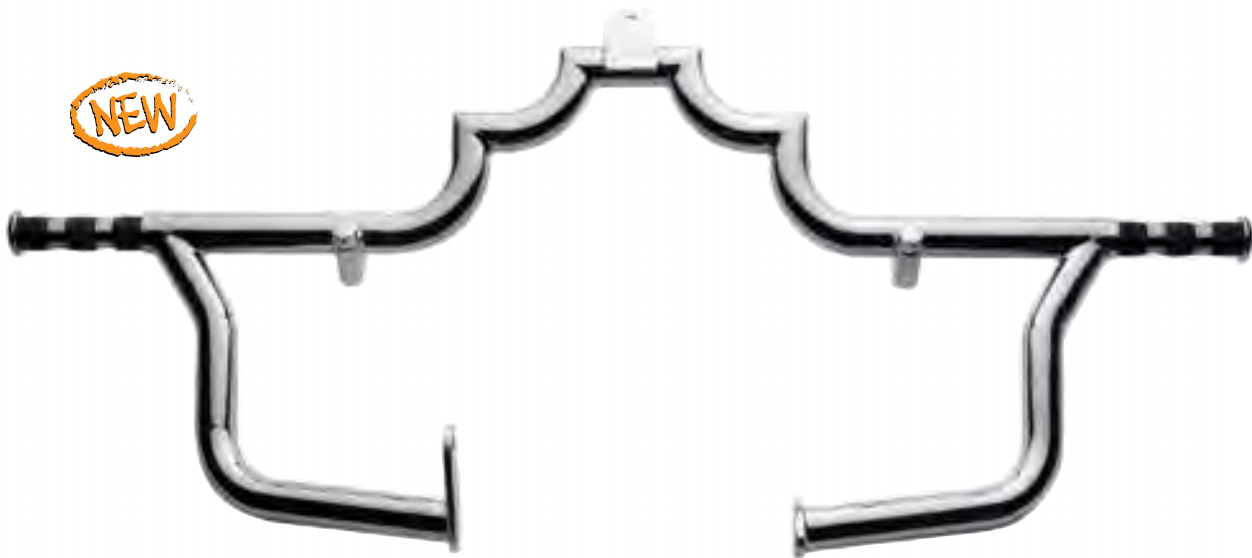

Phantom Highway Bars with Pop-Out Pegs by JBN Custom

- Chrome-plated 1 1/4" tubing
- Combination engine guard and highway peg is engineered with the rider's comfort in mind
- Spring loaded pegs pop out with the push of a button
- Easy installation with included hardware

610600	Fits all Touring models from 1997 to present (except FLTR)	\$279.99
610601	Fits all FL Softail® models from 1986 thru 1999	\$279.99
610602	Fits all FL Softail® models from 2000 to present	\$279.99

Note: Always check to make sure there is adequate ground clearance on motorcycles that have been lowered.

31607



31416



Khrome Werks® Chrome Highway Bars for FL Softail® Models

Heavy gauge, 1" diameter steel tubing. For that classic 50's look. Front bar kit includes a special oil cooler relocation bracket. All necessary mounting hardware included. Front bar kits available with or without highway peg mounts. Made in USA.

- 31607** Front highway bar for FL Softail® models from 1986 thru 1999 **\$159.99**
- 31416** Rear highway bar for all FL Softail® models from 1986 to present (except Fat Boy® models). Also works well in conjunction with our Khrome Werks® Trailer Hitch for Softail® models from 1986 to present (CC #31414) **\$179.99**

Warning: These highway bars are for cosmetic use only and will not provide leg or vehicle protection in the event of a low speed fall. They are not made nor intended to provide protection from bodily injury in a collision with an automobile or any other object.

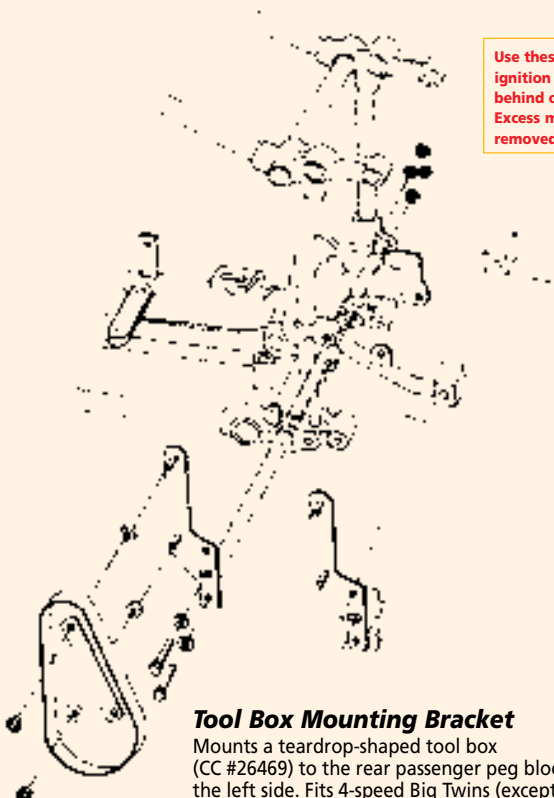

Use these holes if ignition switch is behind oil tank. Excess may be removed.

Tool Box Mounting Bracket

Mounts a teardrop-shaped tool box (CC #26469) to the rear passenger peg block on the left side. Fits 4-speed Big Twins (except Softail® models) from 1977 thru 1986. The stock passenger pegs may be turned upside down or relocated to the bottom stock stud as on earlier models.

26525 Bracket only \$34.99



Teardrop Tool Boxes

Our popular chrome reproductions of the Original Equipment 'teardrop' tool box used from 1940 thru 1959 are available in two different versions, with your choice of the old-style lock or a more modern, conventional tumblers lock for improved security.

26457 Tool box with conventional tumbler lock \$49.99

26474 Replacement key for old-style lock (sold in pairs) \$4.49

Colony Tool Box Mounting Kit

36183 A complete hardware kit for mounting the tool box on models from 1936 thru 1961 \$17.99

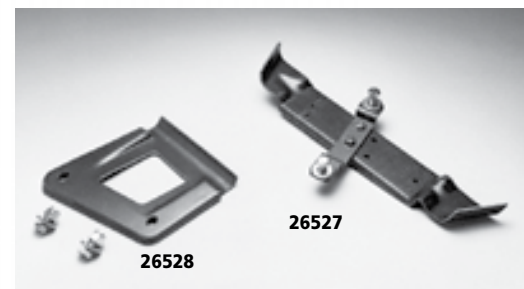

Tool Box Mounting Brackets

Original-style weld-on mounting brackets to mount CC reproduction tool boxes on vintage models. This bracket will work on stock as well as most custom rigid frames.

26527 1937 thru 1952 bracket. Mounts either the square or teardrop (CC #26469) tool box \$31.99

26528 1953 thru 1957 bracket. Mounts the teardrop shape (CC #26469) tool box only \$29.99



Teardrop Toolboxes for Softail® Models

Add a classic touch to your Softail® model with a chrome-plated replica of the toolbox used from 1940 thru 1959. The chrome-plated mounting brackets are held by the fender support bolts and passenger footrest. Left-side kit is ideal for Fat Boy® and FLSTN models because of the shotgun exhaust. Fit Softail® models from 1984 thru 1999 (except 1990-up Heritage Softail® Classic models).

09767 Left-side kit \$79.99



Nylon Tool Pouch

Removable toolbox insert fits stock and reproduction teardrop toolboxes on Big Twins from 1940 thru 1959. Made of 1000 denier nylon with water-resistant urethane coating and double-stitched with nylon thread. Tools not included.

29088 Nylon tool pouch \$15.99

KICKSTANDS - ANGLE PLATES



28209



28208



Pro-One™ Kickstand Angle Plate for Softail® Models

Lowered bikes can make Original Equipment side stands nearly useless, leaving a bike precariously balanced when parked. This clever design restores the correct angle to the kickstand to support the bike safely.

65303 Fits all Softail® models from 1984 thru 1999 \$19.99

'Burly' Kickstand Angle Plates by White Bros.

Correct the kickstand angle of modified bikes before they fall over. Billet aluminum angle plates mount under the kickstand to quickly provide a stable and aggressive look when parked. Includes hardware and shims.

28207 For lowered Softail® models from 1984 thru 1999 \$79.99

28208 For improved kickstand angle on Touring models from 1993 thru 2007 \$79.99

28209 For lowered Touring models from 1993 thru 2007 \$79.99



Ness 1" Lowered Kickstands

- A must when lowering your bike
- Available for both Touring and Softail® models
- Chrome-plated forged steel



631098 Fits 1984-2006 Softail® models \$79.99

631100 Fits 2007 to present Softail® models \$79.99

631099 Fits 2007 to present Touring models \$79.99



Ness Custom Kickstand Kit

- Works with lowered bikes
- Chrome steel mount
- Designed for 4-Speed Big Twin and Softail® model frames from 1941-1999 and FXR models
- Kit includes the necessary hardware and chrome-plated spring
- Replacement kickstand includes the kickstand arm, spacer and spring

631097 Complete kickstand kit \$212.99

631096 Replacement kickstand \$86.99



631094



631095

Ness Hidden Spring Kickstand Kits

- The ultimate in custom kickstands for your lowered application
- Features internal spring loaded ball bearing lock for a cleaner look and optimum functionality
- The telescopic chrome kickstands are adjustable in height by 1 inch
- Mounting brackets are machined from polished stainless steel to eliminate chrome wear in high contact areas
- All of these kits feature a hidden ball bearing design return spring for positive stock feel and retaining clean look

631094 Telescopic kickstand for 1984-1999 Softail®, 4-speed Big Twins and custom applications \$199.99

631095 Rad II kickstand for 1984-1999 Softail®, 4-speed Big Twins and custom applications \$249.99