



World's Finest Products For Harley-Davidsons™

PRODUCT LINE FOR  
Buell® Motorcycles  
SPECIAL



[WWW.CUSTOM-CHROME-EUROPE.COM](http://WWW.CUSTOM-CHROME-EUROPE.COM)



**Mounting Kit**

**LSL Aluminum Frame Sliders for Buell® XB9/XB12 Models**

These kits are made of CNC-machined aluminum and are available your choice of 5 different colors/finishes for the pads. They fit Buell XB9/XB12 models to protect important parts in case of a crash. The inner ring is replaceable. Mounting kit and pads are sold separately.

**Mounting Kit**

**687650** Fits all XB9/XB12 models

**Pads**

- 687651** Silver
- 687652** Titan
- 687653** Black
- 687654** Chrome
- 687655** Carbon



**LSL Swingarm Protectors for Buell® XB9/XB12 Models**

Mounted at the end of the rear axle to protect the oil bag in the swingarm of XB9 and XB12 models, in the event of a crash.

- 687656** Silver
- 687657** Titanium
- 687658** Black



**LSL Superbike Kit with TÜV for Buell® XB9/XB12 Models**

Superbike conversion kit with aluminum upper triple tree, brake line and all required hardware for installation. Improved handling and a better riding position (in conjunction with LSL Super-bike handlebar) is the result. Handlebar is not included.

**687634** Superbike conversion kit



**LSL Steering Damper with TÜV for Buell® XB9/XB12 Models**

High-quality steering dampener made in Germany by LSL. Adjustable in 7 steps with eloxated aluminum housing. Includes mounting kit.

**687635** Steering dampener kit



**LSL 7/8" Street Handlebars with TÜV for Buell® Models**

The Street Bar is an aggressively-styled handlebar with a low rise. Available in stainless steel or aluminum. Measure 32"-wide (81cm) x 1.75"-tall (4.5cm).

- 687643** Aluminum – silver
- 687644** Aluminum – titanium
- 687645** Aluminum – gold
- 687638** Stainless steel – chrome
- 687639** Stainless steel – flat black



**LSL 7/8" Superbike Handlebars with TÜV for Buell® Models**

Classic Handlebar for a comfortable riding position. Available in stainless steel or aluminum. Measure 30.75"-wide (78cm) x 4.75"-tall (12cm).

- 687640** Aluminum – silver
- 687641** Aluminum – titanium
- 687642** Aluminum – gold
- 687636** Stainless steel – chrome
- 687637** Stainless steel – flat black

**LSL Footpegs for Buell® XB 9/XB 12 Models**

Superbly styled with a sporty look. Made of high-quality aluminum. Knurled design to provide excellent grip. Comes with male mount adapter to mount the pegs rear or for the driver. No modification required, fits to the OEM location.



**Footpegs**

- 687661** Silver
- 687662** Titanium
- 687663** Black anodized

**Male Mounts**

- 687659** Front
- 687660** Rear



**LSL Bar Sliders for Buell® XB9/XB12 Models**

These bar sliders come with a black plastic inner protector. They're intended for use with 7/8"-diameter aluminum or stainless steel handlebars. Sold in pairs.

**Bar Sliders for Aluminum Handlebars**

- 687646** Silver
- 687647** Titanium
- 687648** Black
- 687649** Chromed stainless steel

**Bar Sliders for Steel Handlebars**

- 687669** Silver
- 687670** Titanium
- 687671** Black
- 687672** Chromed stainless steel



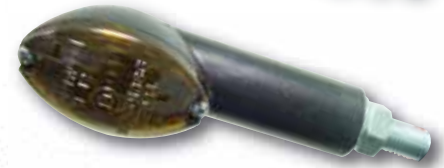

**LED Turn Signals**

- ABS housing
- Clear lens
- E-Mark
- Sold each
- Measure: A=58mm, B=28mm



- 1002574** Carbon Fiber look – left
- 1000032** Carbon Fiber look – right
- 1002575** Black – left
- 1000033** Black – right
- 1002576** Chrome – left
- 1000034** Chrome – right

**Short Cateye Turn Signals**

- ABS housing
- Clear lens
- E-Mark
- Sold each
- Measure: A=66mm, B=28mm



- 1002612** Carbon Fiber look – left
- 1002613** Carbon Fiber look – right
- 1002614** Black – left
- 1002615** Black – right
- 1002616** Chrome – left
- 1002617** Chrome – right

**Long Cateye Turn Signals**

- ABS housing
- Clear lens
- E-Mark
- Sold each
- Measure: A=82mm, B=28mm



- 1002618** Carbon Fiber look – left
- 1002619** Carbon Fiber look – right
- 1002620** Black – left
- 1002621** Black – right
- 1002622** Chrome – left
- 1002623** Chrome – right



**LED Turn Signals**

- ABS housing
- Clear lens
- E-Mark
- Sold each
- Measure: A=63mm, B=28mm



- 1002586** Carbon Fiber look
- 1002587** Black
- 1002588** Chrome

**LED Turn Signals**

- ABS housing
- Clear lens
- E-Mark
- Sold each
- Measure: A=70mm, B=30mm



- 1002591** Carbon Fiber look
- 1002590** Black
- 1002592** Chrome

**LED Turn Signals**

- ABS housing
- Clear lens
- E-Mark
- Sold each
- Measure: A=86mm, B=28mm



- 1002594** Carbon Fiber look
- 1002593** Black
- 1002595** Chrome

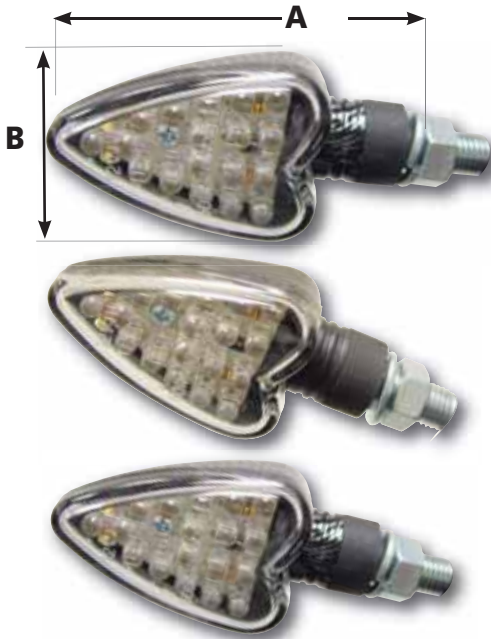

**LED Turn Signals**

- ABS housing
- Clear lens
- E-Mark
- Sold each
- Measure: A=70mm, B=36mm



- 1002632** Carbon Fiber look
- 1002631** Black
- 1002633** Chrome



**LED Turn Signals**

- ABS housing
- Clear lens
- E-Mark
- Sold each
- Measurements: A=86mm, B=36mm



- 1002583** Carbon Fiber look
- 1002584** Black
- 1002585** Chrome



**LED Turn Signals**

- ABS housing
- Clear lens
- E-Mark
- Sold each
- Measure: A=48mm, B=17mm



- 1002580** Carbon Fiber look
- 1002581** Chrome
- 1002582** Black



**LED Turn Signals**

- ABS housing
- Clear lens
- E-Mark
- Sold each
- Measure: A=88mm, B=36mm



- 1002629** Carbon Fiber look
- 1002628** Black
- 1002630** Chrome



**LED Turn Signals**

- ABS housing
- Clear lens
- E-Mark
- Sold each
- Measure: A=106mm, B=34mm



- 1002640** Black
- 1002641** Chrome
- 1002642** Carbon Fiber look

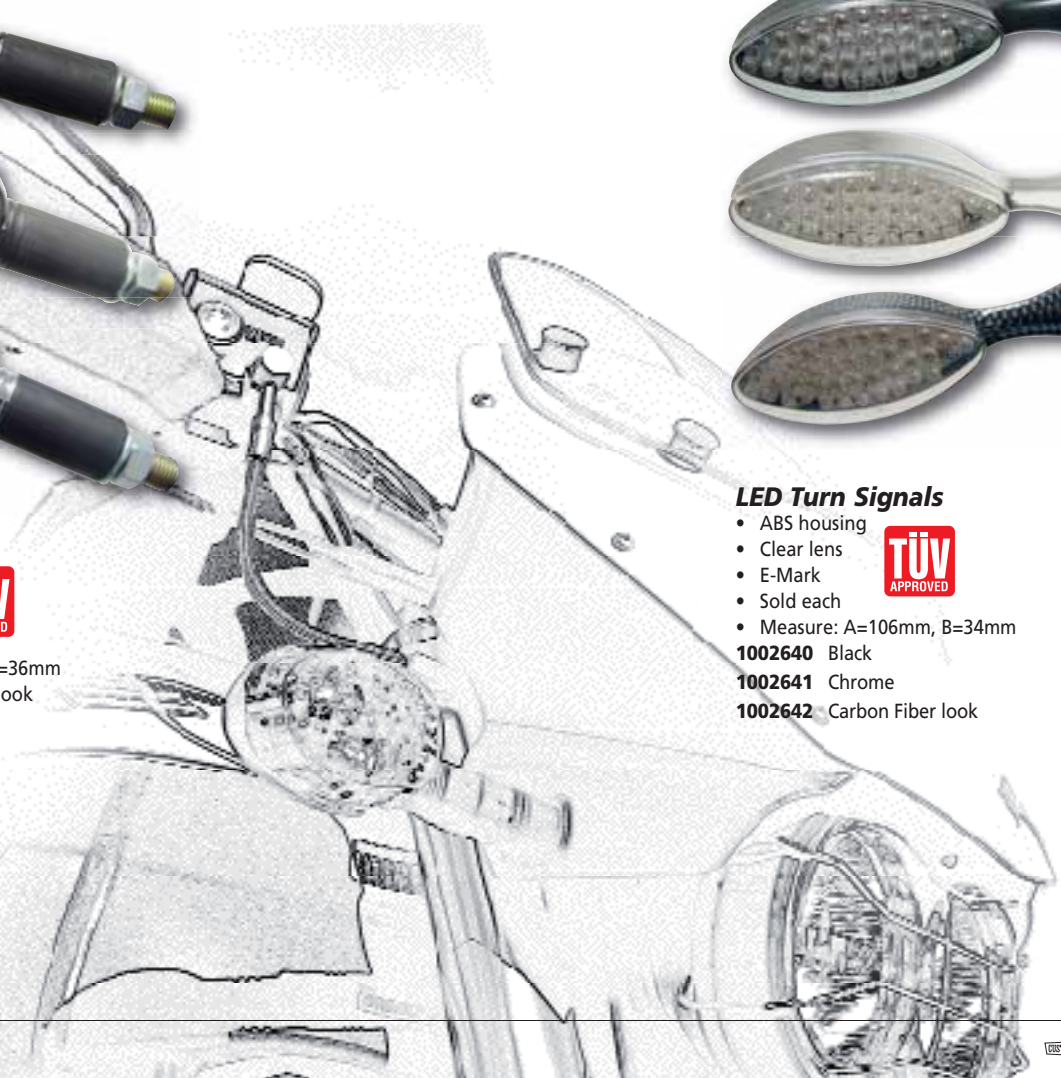



**Yuasa®**

**Big Boar Odyssey®(10)**

Models	Application	Yuasa®			High Performance Maintenance Free		Big Boar Odyssey®(10)	
		Conventional	Yumicron	Yumicron CX	Maintenance Free	Maintenance Free	Maintenance Free	Drycell®
Buell®	X1, S3, S3T & M2	—	—	—	2831560 (8)	2831668 (8)	618892	59860
Models	S2, S2T, RR1200, RS1200, RSS1200 and RR1000	—	—	2831465	2831565 (8)	2831667 (8)	618893	59860
	S1	—	—	—	2831489 (6)(8)	—	—	59860 (3)
	2000 to Present XB9R, XB9S, XB12R, XB12S	—	—	—	2831489 (8)	—	—	—

(2) Part is smaller than OEM battery.

(3) Shim pad required on lower battery tray.

(4) Terminals extend above battery casing and may require cutting of battery box cover for proper installation.

(5) Battery mounts on its side and cables must be rerouted.

(6) Must use adapter kit available from Buell®.

(7) Battery Tender or similar type auto-cutoff battery charger must be used with this product or warranty is void.

(8) Ground Freight Only

(9) May require use of cover/spacer kit (CC #2831629)

(10) When charging Odyssey batteries CC #15285 (on page 6.73) should be used.



MODEL	YEAR	V	AH	REFERENZ/TYPE	VARTA		MOTOCCELL	
					PART #	TYPE	PART #	TYPE
<b>BUELL</b>								
RR 1000	87-	12	18	YTX20-BS	686616	LF	693318	W
M2 Cyclone	97-02	12	18	YTX20L-BS	686615	LF	693319	W
RR 1200	88-90	12	18	YTX20-BS	686616	LF	693318	W
RS 1200	89-93	12	18	YTX20-BS	686616	LF	693318	W
RSS 1200	91-93	12	18	YTX20-BS	686616	LF	693318	W
S1 Lightning	96-99	12	12	YTX14-BS	1000461	LF	693314	W
S2, S2T Thunderbolt	94-96	12	18	YTX20-BS	686616	LF	693318	W
S3, S3T, Thunderbolt	97-02	12	18	YTX20L-BS	686615	LF	693319	W
X1 Lightning	99-02	12	18	YTX20L-BS	686615	LF	693319	W
Blast	00-03	12	12	YTX14-BS	1000461	LF	693314	W
XB9R Firebolt	02-03	12	12	YTX14-BS	1000461	LF	693314	W
XB9S Lightning	02-03	12	12	YTX14-BS	1000461	LF	693314	W

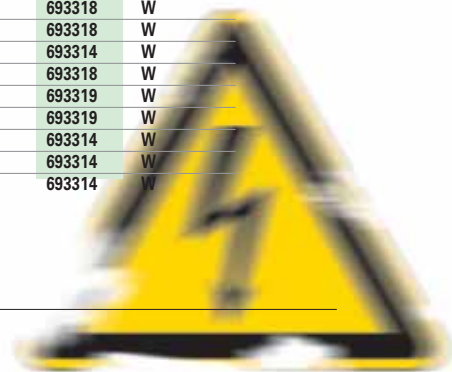



**Standard Spark Plugs**

			Accel® U-Groove			Autolite Standard			Champion Copper Plus		
Size	Model	OEM	Qty	Accel #	Part #	Qty	Autolite #	Part #	Qty	Champion #	Part #
1200cc	Buell® models 1988-03	6R12	2	2418	22016 . . . .	4	4164	22183 . . . .	8	RA8HC	22122

**Premium Spark Plugs**

			Accel® CycleLite™ Platinum			Autolite Finewire Platinum			NGK Iridium IX®		
Size	Model	OEM	Qty	Accel #	Part #	Qty	Autolite #	Part #	Qty	NGK #	Part #
1200cc	Buell® models 1988-up	6R12	2	Y2418P	22023 . . . .	2	MP4164	22161 . . . .	4	DCPR7EIX	3126046 . . .

Note: NGK Iridium IX® spark plugs are priced each, but sold in boxes of 4.... please order accordingly.

**NGK Standard Spark Plugs**

NGK is the leader in motorcycle spark plugs, with spark plugs for virtually every motorcycle. The "Standard" spark plug is considered the workhorse at the heart of smooth-running engines around the world.

- OEM approved
- Triple-gasket sealing process
- Consistent performance
- Spark plug of choice in millions of motorcycles
- Specified by more motorcycle manufacturers than any other spark plug company
- Priced each, but sold in boxes.... please order accordingly



Size	Model	Qty	NGK #	Part #
1200cc	Buell® models 1988-up	10	DCPR7E	3123932



**Accel® '300+' Plug Wire Sets**

8.8mm core has 300% greater current capacity than most other 'high-performance' ignition wires, yet still suppresses radio frequency interference that electronic ignition systems demand.

**23825** Fits all Buell® models from 1996 thru 1998

**23826** Fits all Buell® models from 1999 thru 2003





**D&D Full Systems for Buell® Models**

Gain up to 25% more power with these hot designs from D&D. 30 years of race tuning experience ensure the highest performance available for your Buell® motorcycle.

**For Buell® X-1, M-2, S-3 and S-3T Models**

**5495018** Polished stainless steel finish head pipes with black powder coated muffler

**5495019** Faux Ti finish head pipes with black powder coated muffler

**For Buell® XB9R, XB9XS Models**

**5495030** Black ceramic slip-on



5495018



5495018



5495030



**Sebring Mufflers with EGIABE for Buell® XB9R and XB12R Models**

Come complete with easy-to-remove baffles. Made of stainless steel and include EG/ABE certificate (with baffles in use ONLY). Built with two mufflers for the left and right sides of the bike and come ready to slip onto the stock headpipes with the included bracket.

**686895** Fits Buell® XB9R Firebolt™ and XB9S Lightning® models from 2003 to present

**686896** Fits Buell® XB12R Firebolt™ and XB12S Lightning® models from 2004 to present









**Mikuni 'HSR42' and 'HSR45' Smoothbore Carburetors and Kits**

Improve starting, rideability, power and torque. The adjustable accelerator pump and smoothbore design combine to give a big increase in air flow over the earlier 'HS40' for excellent throttle response in any riding situation. Other features include a two-piece throttle slide that rolls on stainless roller bearings, a lighter throttle return spring, a low-speed air screw, and an enlarged needle valve and float bowl. All kits are specifically designed for each application.

**HSR42 'Easy' Carburetor Kits**

High-performance kits mount to stock intake manifold and include the carburetor, adapters, air cleaner cover (where necessary), and detailed installation/tuning manuals.

**23406** Fits 1200cc Sportster® and carbureted Buell® models from 1994 thru 2003 (requires aftermarket high-performance air cleaner assembly)



**Dynojet Tuner Kits for Keihin 'CV' Carburetors**

Eliminates flat spots in Keihin constant velocity (CV) carburetors. Permits easy tuning of the carbs on stock motors as well as motors with performance cams and exhausts. Each kit includes instructions, a selection of main jets, a needle jet, an adjustable needle with spacers and circlips, a spring, and drill bits.

**615832** Fits Buell® Cyclone® models from 1999 thru 2002

**Mikuni 'HSR42' and 'HS40' Smoothbore Carburetor Kits with TÜV Approval**

Complete carburetor kits for a variety of Evolution® Big Twin and Sportster® models from 1985 to present. The HSR42 kits are Mikuni's popular "Easy" kits which re-use your Original Equipment manifold, cables and air cleaner through the use of an adapter. The HS40 kits are the "Total" kits which include everything necessary for installing them on an engine.

HSR42	HS40	Application
<b>85080</b>	n/a	Fits all Buell® models from 1996 thru 2002

**RevTech® Digital Fuel Optimizer**



The Red run is a stock EFI Road Glide. The Blue run is with a Power Commander installed. The Green run is with the DFO added.

**RevTech® Stealth DFO XB Models**

The Stealth DFO has OEM-style connectors for an effortless installation.

**601203**



shown for reference only

**K&N Replacement Air Filters**

These world renowned filters combine unsurpassed air flow and dirt-trapping performance. Made with pleated gauze and designed to be washed and reused twenty five of times. Use the K&N Recharger kit to keep performance going virtually forever.

Description	Replaces OEM #	K&N
Fits all Buell® models with carburetors (except Blast® models) from 1996 thru 2000	29239-96Y	22165
Fits Buell® XB95, XB12S, XB9R and XB12R models from 2002 to present		5560005



**Forcewinder XR2 Air Intake System**

All the features of the regular Forcewinder XR, with the added benefit of a head breather kit. Available with polished, or black elbow.

**For Fuel Injected Buell® Models from 1998 thru 2001**

**681008** Gloss Black elbow

**681009** Crinkle Black elbow

**For Carbureted Buell® Models**

**647401** Polished elbow

**For Fuel Injected Buell® Models from 1998 thru 2001**

**47963** Polished elbow





RACEWAY



Standard

Big Axle

**JIMS® 'Big Axle' Powerglide™ Tappets**

All-new design improves tappet reliability by eliminating the inner bearing race. Simplifying the design of the tappet increases the wall thickness of the roller by 27%, and provides a 36% increase in the size of the tappet axle. The result is a tappet with twice the strength and stability of the stock design. Sold each.

**For Evolution® Big Twin Models from 1984 thru 1999 and Evolution® Sportster® and Buell® Models from 1986 thru 1990**

Hydraulic tappets compatible with the Original Equipment tappet blocks.

**20732** Standard (repl. OEM 18523-86)

**20733** .005" oversize



**Crane® Hydraulic Roller Tappets**

Increase the performance of your valvetrain with this new tappet design. Made from high-strength steel alloy that is precision-machined on CNC equipment and heat-treated for strength and wear-resistance. Components are computer-matched and measured to tolerances of microns for more precise oil metering and improved oil control, permitting the valvetrain to reliably perform up to 500 RPM higher than stock tappets. Sold each.

**20257** Fits Evolution® Sportster® and Buell® models from 1991 thru 1999



**JIMS® 'Powerglide™' Hydraulic Tappets**

Designed for high-performance. Won't collapse at high RPM. The performance of a solid lifter combined with full compensation for heat expansion. These tappets are coated with a special dicronite DL-5 coating, and hand-fitted to achieve a running fit of .0002" to eliminate hydraulic tappet collapse.

**For Twin Cam 88® Models from 1999 to Present, and Sportster® and Buell® Models from 2000 to Present**

**22351** Standard .8425" O.D. (sold each)



**JIMS® Hydrosolid Tappets**

Safely add more horsepower to your higher RPM levels with the simple installation of Hydrosolids. Use with any cam be it solid or hydraulic, and receive 3 to 6 more usable horsepower from about 5600 RPM, to the safest RPM level possible for your valve train. Hydrosolids have a built in anti pump-up device, so the tappets will not pump-up, preventing valve contact. Sold each.

**For Twin Cam 88® Models from 1999 to Present and Sportster® and Buell® Models from 2000 thru 2003**

**22306** Standard .8425" O.D. (repl. OEM 18538-99)

**22350** Long .8425" O.D. 1/4" longer than standard





**Andrews Adjustable Pushrods for Evolution® Engines**

The aluminum pushrods are lighter and quieter while the chromemoly pushrods are more rigid and provide more strength. All pushrods are the same diameter as stock and fit all Evolution® Big Twin and Sportster® models from 1984 thru 2003.

**For 5-Speed Sportster® and Buell® Models from 1991 thru 2003**  
**24595** Chromemoly

**JIMS® Titanium Pushrods**

The latest in valvetrain technology specially made for the high demand of reducing reciprocating weight in the V-Twin valvetrain.

- Features pushrod adjuster that screws thread directly into main body with no inserts required, 24 pitch thread, 3/8" ball-end rocker, oil through ball ends and gun drilled titanium bar stock
- Pushrod installation does not require disassembly of top end or removal of cam
- Machined out of special titanium alloy
- Weighs only 67 grams but is as strong as chromemoly!

**671013** Fits Evolution® Sportster® and carbureted Buell® models from 1991 thru 2003



**Andrews Cam Kits for Evolution® Sportster® and Buell® Models**

These are the most popular cam kits for Evolution® Sportster® and Buell® models that Andrews sells. Fit all 883cc thru 1200cc models from 1986 thru 1999.

**'V2' and 'N2' Cams and Cam Kits**

Bolt-in cams for stock 883cc-1200cc engines with extra power from 2000-6000 RPM. Stock springs and hydraulic lifters are recommended. Can be used with stock pushrods. Available kitted with the cams and four adjustable aluminum push-rods, or the cams are available by themselves.

**24207** 'N2' Cams ONLY (1991 thru 1999 models)

**'V4' and 'N4' Cams and Cam Kits**

Street/drags: For stock or modified 883cc-1200cc engines. Has a slightly higher idle speed, but produces power from 2500-6500 RPM. Stock springs and hydraulic lifters are recommended. Can be used with stock pushrods. Available kitted with the cams, four adjustable chromemoly pushrods and a set of titanium upper spring collars, or the cams are available by themselves.

**24208** 'N4' Cams ONLY (1991 thru 1999 models)

**'V6' and 'N6' Cams**

For modified 1200cc engines and high-compression pistons up to 80". These cams produce power from 2500-6500 RPM. Stock springs and lifters are recommended. Can be used with stock pushrods.

**23913** 'N6' Cams ONLY (1991 thru 1999 models)

**'V8' and 'N8' Cams**

For modified 1100cc-1200cc and stroked 883cc engines. Produces great mid-range power from 2000-6000 RPM. Stock springs and hydraulic lifters recommended. Can be used with stock pushrods.

**23915** 'N8' Cams ONLY (1991 thru 1999 models)

**'V80' and 'N80' Cams**

For highly-modified 61"-77" engines with at least 10.5:1 high-compression pistons and head work. These cams produce power beyond 6500 RPM. Hydraulic lifters and good-quality adjust-able pushrods are recommended. Hi-lift valve springs and collars (CC #24198, #24199) must be used.

**23917** 'N80' Cams ONLY (1991 thru 1999 models)





**For 1200cc Evolution® Sportster® and Buell® Models from 1988 thru 2003**

Designed for use with stock heads, but not with 101hp Thunderstorm™ heads. Use stock piston rings (see page 9.29).

**3 1/2" Bore with 3 13/16" Stroke and 9:1 Compression**

**47078** +.010" oversize

**47079** +.020" oversize

**3 1/2" Bore with 3 13/16" Stroke and 10.5:1 Compression**

**47253** Standard

**47254** +.010" oversize

**47255** +.020" oversize

**For 1200cc Evolution® Sportster® and Buell® Models with Thunderstorm™ Cylinder Heads from 1988 thru 2003**

Designed for use with 1998 thru 2002 Buell® Thunderstorm™ cylinder heads. Use stock piston rings (see page 9.29).

**3 1/2" Bore with 3 13/16" Stroke and 10:1 Compression**

**47265** Standard

**47266** +.010" oversize

**47267** +.020" oversize

**3 3/4"-Bore Piston Kits for Evolution® Sportster® and Buell® Models from 1986 thru 2003**

These kits were designed for use with stock 1200cc Sportster® and Buell® cylinder heads (not Screamin' Eagle® or Thunderstorm™ heads) and will increase the engine size to 84 cu. in. The crankcases must be bored to accept larger cylinders.

**3 3/4" Bore with 3 13/16" Stroke and 9.5:1 Compression**

**47272** Standard



**JE Forged Piston Kits**

JE Pistons are CAD-designed and fully CNC-machined. Made of the finest aircraft quality 2618 extruded billet aluminum. JE Pistons, Inc. is QS-9000 approved to insure superior quality control through the entire manufacturing process. All kits include two pistons, wrist pins and circlips.

**For Buell® Models with Thunderstorm Heads**

**3 1/2" Bore with 3 13/16" Stroke and 10:1 Compression**

**49578** +.005" oversize

## Throttle Cables

Description	Replaces OEM #	Black Vinyl		Braided Stainless Steel		Armor Coat Braided Steel		Sterling Chromite II™	
		Std. Length	Over Length	Std. Length	Over Length	Std. Length	Over Length	Std. Length	Over Length
<b>For Buell® Models</b>									
Blast® P3 2000 to present	NO307.KA	685010				685015			
Cyclone® M2 1997-1998	56429-96Y	685012							
Cyclone® M2 1999-2002	NO307.KA	685010				685015			
Cyclone® M2 Low 2001-2002	NO307.KA	685010				685015			
Lightning® S1 1996-1998	56429-96Y	685012							
Lightning® X1 1999-2002	NO307.KA	685010				685015			
Thunderbolt™ S2 1994-1996	56324-81C	28125	27892 (+6")			41607		45100	45101 (+6")
Thunderbolt™ S3 1997-1998	56429-96Y	685012							
Thunderbolt™ S3 1999-2001	NO307.KA	685010				685015			
Thunderbolt™ S3T 1997-1998	56429-96Y	685012							
Thunderbolt™ S3T 2000-2002	NO307.KA	685010				685015			
White Lightning S1W 1998	56429-96Y	685012							

## Throttle Cables

Description	Replaces OEM #	Black Vinyl		Braided Stainless Steel		Armor Coat Braided Steel		Sterling Chromite II™	
		Std. Length	Over Length	Std. Length	Over Length	Std. Length	Over Length	Std. Length	Over Length
<b>For Buell® Models</b>									
Blast® 2000 to present	NO308.KA	685011				685016			
Cyclone® M2 1997-1998	56430-96Y	685013							
Cyclone® M2 1999-2002	NO308.KA	685011				685016			
Cyclone® M2 Low 2001-2002	NO308.KA	685011				685016			
Lightning® S1 1996-1998	56430-96Y	685013							
Lightning® X1 1999-2002	NO308.KA	685011				685016			
Thunderbolt™ S2 1994-1996	56323-81C (33")	28124	27891 (+6")		14681 (+6")	41605	41606 (+6")	45120	45121 (+6")
Thunderbolt™ S3 1997-1998	56430-96Y	685013							
Thunderbolt™ S3 1999-2001	NO308.KA	685011				685016			
Thunderbolt™ S3T 1997-1998	56430-96Y	685013							
Thunderbolt™ S3T 2000-2002	NO308.KA	685011				685016			
White Lightning S1W 1998	56430-96Y	685013							

## Throttle Cables

Description	Replaces OEM #	Terminator Black Vinyl		Armor Coat Braided Steel		Sterling Chromite II™ Braided Steel	
		Std. Length	Over Length	Std. Length	Over Length	Std. Length	Over Length
<b>For Buell® Models</b>							
S2 1995	38619-86A (54")			13937	14698 (+6")		
Cyclone® M2/M2 Low 1997-2002	38656-96Y					45180	45181 (+6")
Lightning® S1 1996-1998	38656-96Y						
Lightning® X1 1999-2002	38656-96Y						
Thunderbolt™ S3/S3T 1997-2002	38656-96Y						

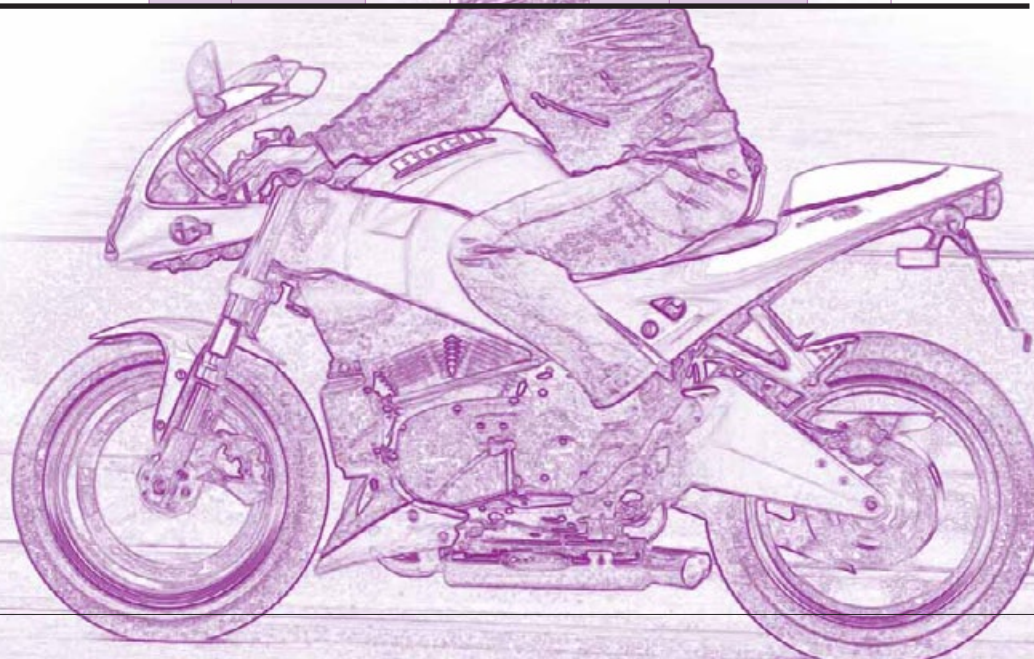



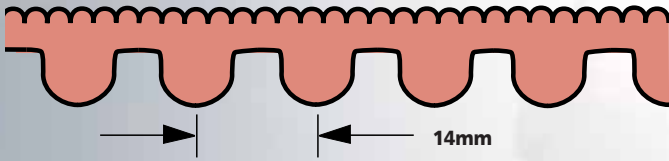

**14mm Gates HTD® Poly Chain® Drive Belts**  
**43117** 1 1/8"-wide, 128-teeth

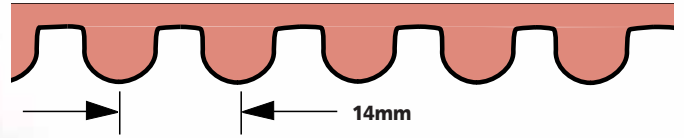

**14mm Dayco™ 'Panther' Ultra Cord® Drive Belts**  
**42753** 1 1/8"-wide, 128-teeth

**Tires**



**Dunlop D208GP High-Performance Sport Radial Tires for Buell® Models**

- Race-tire compound and track-going profiles give the D208GP unparalleled grip, excellent drive out of corners, exceptional steering response and superior on-the-track handling
- New construction delivers increased bump absorption for a smooth ride and offers a more "forgiving" nature that allows to change lines through corners as needed
- Jointless Band construction in the rear tire yields "bolt-on" performance right off the shelf with minimal set-up
- D208GP tread pattern is identical to the D208GP national championship-winning tire and provides maximum footprint area and superior cornering grip

**Front Tire**  
**1361144** 120/70ZR x 17" Blackwall

**Rear Tire**  
**1361145** 180/55ZR x 17" Blackwall



# GALFER

## Galfer Brake Pads Street-Front for Buell Models

### Organic Street & Off-Road "G 1054"

1007977 M2 CYCLONE, S3 THUNDERBOLT, X1 LIGHTNING

1007998 SPECIAL M2 CYCLONE

### Sinter/Yellow - GP & Street "G 1375"

1008392 M2 CYCLONE and S3 THUNDERBOLT

1008392 X1 LIGHTNING

### Organic/Purple - Street & Off-Road "G 1651"

1008206 M2 CYCLONE and S3 THUNDERBOLT, X1 LIGHTNING

1008225 SPECIAL M2 CYCLONE

## Galfer Brake Pads Street-Rear for Buell Models

### Organic Street & Off-Road "G 1054"

1007898 M2 CYCLONE, S3 THUNDERBOLT, SPECIAL M2 CYCLONE, X1 LIGHTNING

### Sinter/Yellow - Street & Off-Road "G 1370 & G 1371"

1008419 M2 CYCLONE, S3 THUNDERBOLT, SPECIAL M2 CYCLONE, X1 LIGHTNING

### Organic/Purple - Street & Off-Road "G 1651"

1008130 M2 CYCLONE, S3 THUNDERBOLT, SPECIAL M2 CYCLONE, X1 LIGHTNING



### G 1651/purple

- Semi-metallic High Performance compound
- Used in OE specially in 4-piston calipers
- Powerful and progressive brake feel
- No fade
- Minimal noise
- Minimal loss of efficiency in wet conditions
- Low wear
- No wear of disc
- Use front and rear in sport bikes

### G 1370 & 1371/yellow

- Sintered metall compound
- Progressive brake performance and feel
- No fade
- Minimal noise
- Minimal loss of efficiency in wet conditions
- Low wear
- No wear of disc
- Use: Front and rear in street models

### G 1054/black

- Semi-metallic compound
- Compound of choice for most of our OEM accounts
- Progressive brake performance and feel
- No fade
- Minimal noise
- Minimal loss of efficiency in wet conditions
- Low wear
- No wear of disc
- TÜV approved ABE Nr. 60811
- Use: Front and rear wheels all motorcycles

### G 1375/Yellow

- Sintered metal compound high performance
- Powerful and progressive brake feel
- No fade
- Minimal noise
- Minimal loss of efficiency in wet conditions
- Low wear
- No wear of disc
- Use: Front, sport bikes

## Galfer Wave® Brakedisc Street Front

### DC W

1007820 M2 CYCLONE, S3 THUNDERBOLT, SPECIAL M2 CYCLONE, X1 LIGHTNING

## Galfer Wave® Brakedisc Street Rear

### DF W

1007822 M2 CYCLONE, S3 THUNDERBOLT, SPECIAL M2 CYCLONE, X1 LIGHTNING

### DC W

Full floating Wave® discs with aluminum center carrier



### DF W

Bolt on, non-floating Wave® brake disc





**Brake Pads Street**

**Brake Pads/Front**

**Brake Pads/Rear**

Buell® models		ORGANIC	SINTER	Ferodo	ORGANIC	SINTER	Ferodo
all models	1994 - 1997	4541753		FDB 847	4541357	4541358	FDB 314
all models	1998 - 2002	4542681	4542683	FDB2036	4541297	4542361	FDB 531
Blast® 500	2000 - 2001	4541237	4544073	FDB 664	4541297	4542361	FDB 531
XB9R	2002 -		4544035	FDB2145	4541297	4542361	FDB 531
XB9S / XB9SX 984	2003 -		4544035	FDB2145	4541297	4542361	FDB 531
XB12R	2004 -		4544035	FDB2145	4541297	4542361	FDB 531
XB12S	2004 -		4544035	FDB2145	4541297	4542361	FDB 531

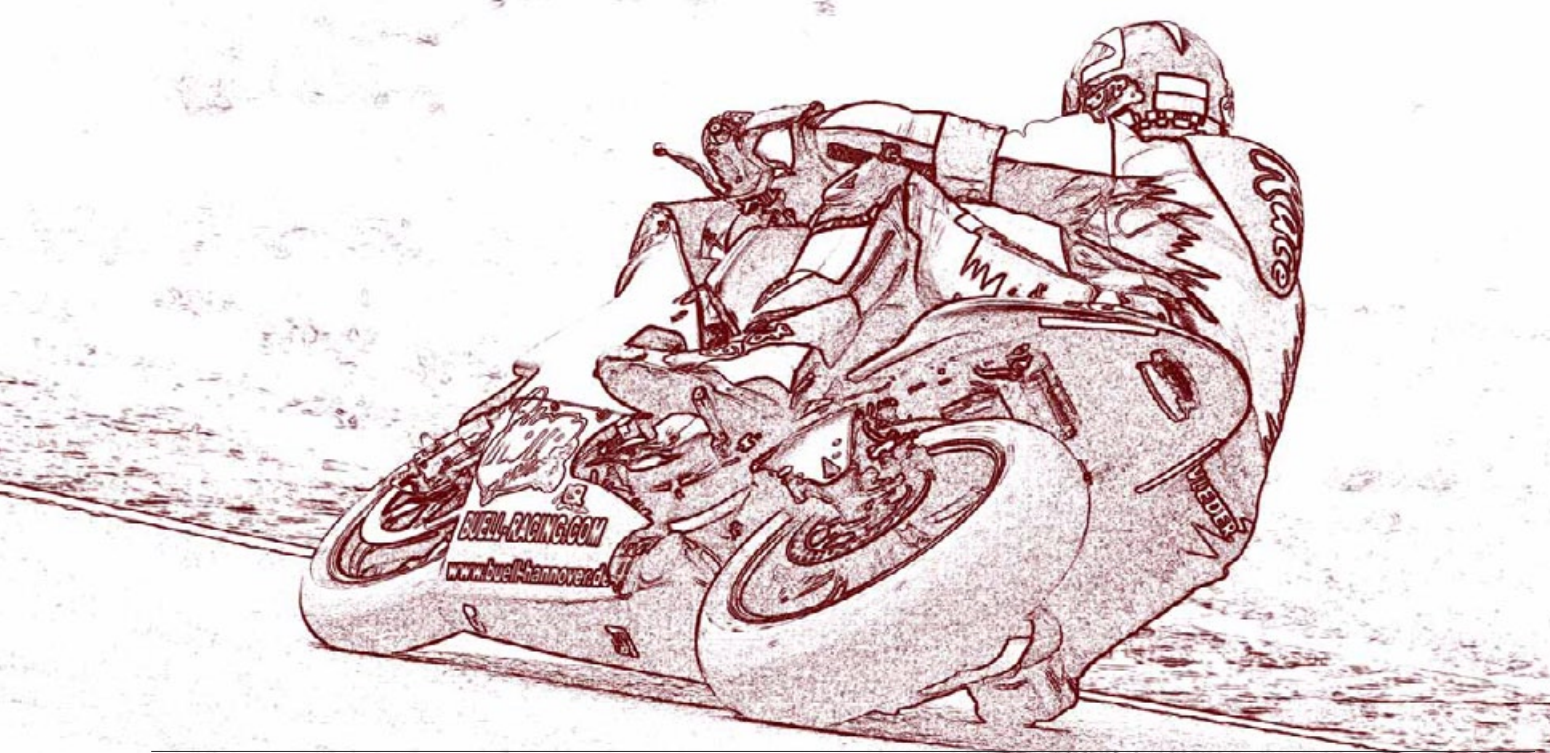



**Racing Wheel Stand Front/Rear**

For all two-wheeler assembly works. Safe - also without assistance! Hoisting device with stable lever construction, indispensable with motorcycles without center stand. Height and width individually adjustable and gold-zinc plated. Inclusive double role set! Special adapters are to be taken from the lower table.

**Scope of supply:**

- 1x basic carrier (complete)
- 2x front jack universal (pair)
- 1x double role set (complete)
- 1x hand lever (extension)
- 1x small parts (screws etc..)

**1002990** Racing Wheel Stand front 'round bends'

**Front adaptor**

**1002992** Radially-adaptor

**1002991** Neck-adaptor

**Special-location bolt**

**1005700** 13,0mm

**1005701** 15,6mm

**1005702** 16,6mm

**1005703** 17,8mm

**1005704** 21mm

**1005705** 23mm

**1005706** 24mm

**1005707** 27mm long

**1005708** 27mm short



Racing Wheel Stand Front/Rear

**Racing wheel stand rear**

· Scope of supply:

- 1x basic carrier (complete)
- 2x role set (complete)
- 1x hand lever (extension)
- 1x small parts (screws etc..)

**1002499** Racing Wheel Stand rear 'round bends'

**Rear adaptor**

**1002486** Racing adaptor M6 pair complete

**1002487** Racing adaptor M8 pair complete

**1002488** Racing adaptor M10x1,25 pair

**1002489** Racing adaptor M12x1,25 pair

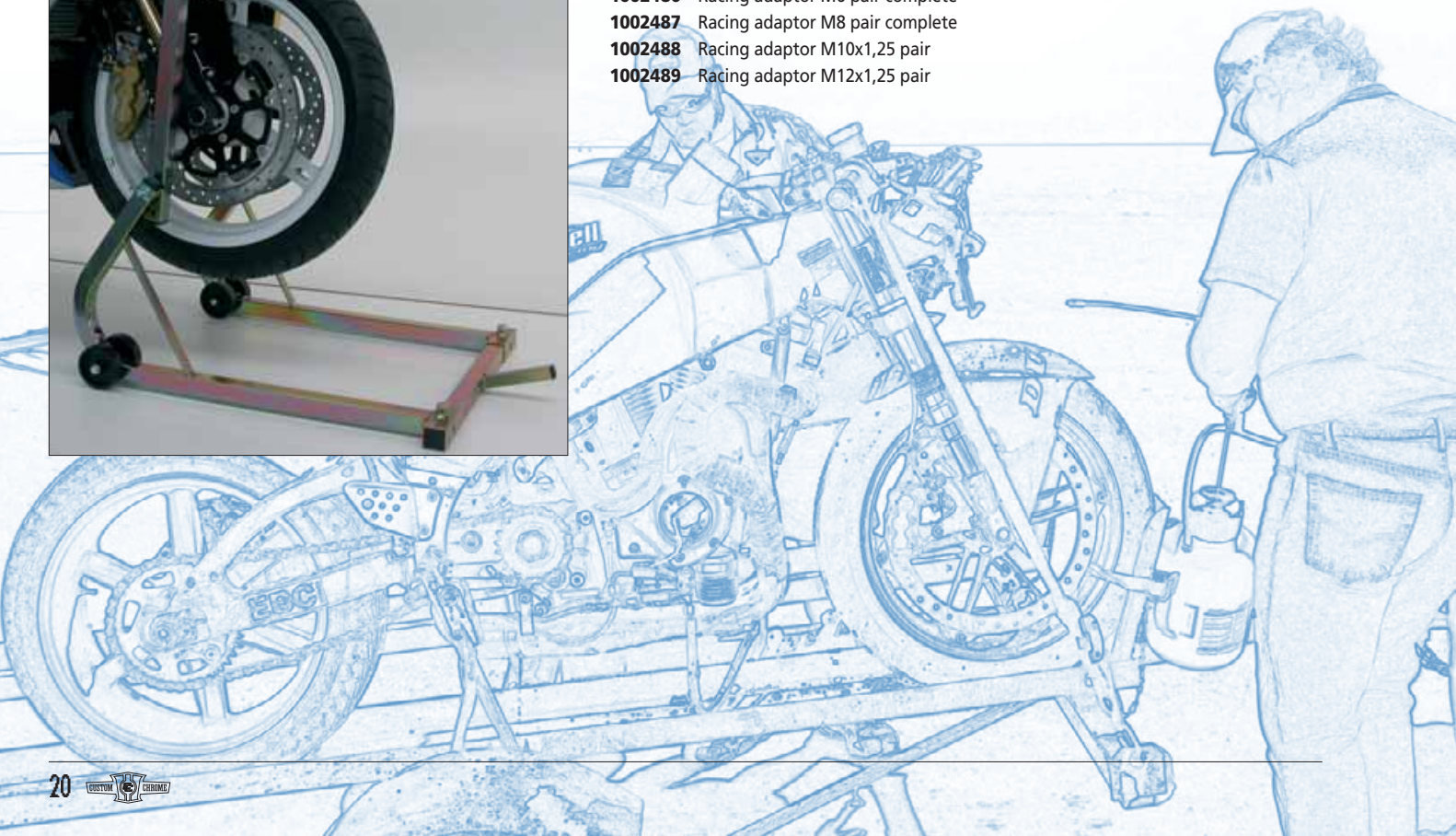



**Three-In-One Truing Stand by K&L Supply**

Make the most of your workspace! This tool allows you to perform the following tasks all at one location, using one fixture.

- Build and true laced wheels
- Balance spoke and cast wheels
- Check for runout (cranks, fork tubes)
- Requires optional dial gauge (sold separately)

**400341** Three in one truing stand

For the past thirty-five years, Custom Chrome and Chrome Specialties, independent companies and divisions of Global Motorsport Group, Inc., have been committed to serving the needs of the Harley-Davidson® rider. Global Motorsport Group's goal has been, and will continue to be, providing the very best and most innovative products possible.

With the exception of the Harley-Davidson Original Equipment parts (indicated by this symbol ) , none of the other products appearing in this catalog are licensed, manufactured, sponsored or endorsed by Harley-Davidson, Inc. Use of the word Harley-Davidson, various model names and designations, and OEM part numbers are provided solely for reference and application information, and there is no affiliation between Harley-Davidson, Inc. and Global Motorsport Group, Inc.

The words: Blast, Buell, Cyclone, Disc Glide, Electra Glide, Evolution, Fat Boy, Firebolt, HD, H-D, Harley, Harley-Davidson, Heritage Softail, Heritage Springer, Hugger, Lightning, Low Rider, Night Train, Revolution, Road Glide, Road King, Screamin' Eagle, Softail, Sport Glide, Sportster, Springer Softail, Sturgis, Super Glide, T-Sport, Tour-Pak, Tour Glide, Twin Cam 88, Ultra Classic, Wide Glide and V-Rod are registered trademarks of H-D Michigan, Inc., of Ann Arbor, Michigan

The words: Bad Boy, Deuce, Duo-Glide, Hydra-Glide and Thunderbolt are trademarks of H-D Michigan, Inc., of Ann Arbor, Michigan

The following model designations for Harley-Davidson motorcycles are used in this catalog for reference only: EL, FL, FLH, FLHC, FLHF, FLHR, FLHRI, FLHRCI, FLHRS, FLHRSI, FLHRSEI, FLHRSEI2, FLHS, FLHT, FLHTC, FLHTCI, FLHTCU, FLHTCUI, FLHTI, FLHTCSE, FLHX, FLST, FLSTC, FLSTCI, FLSTF, FLSTFI, FLSTN, FLSTS, FLSTSI, FLT, FLTC, FLTCU, FLTCUI, FLTR, FLTRI, FLTRSEI, FLTRSEI2, FX, FXB, FXD, FXDI, FXDB, FXDC, FXDG, FXDL, FXDLI, FXDS-Conv., FXDWG, FXDWGI, FXDWG2, FXDWG3, FXDX, FXDXI, FXDXT, FXE, FXEF, FXLR, FXR, FXR2, FXR3, FXR4, FXRC, FXRD, FXRDG, FXRP, FXRS, FXRSE, FXRS-Conv., FXRS-SP, FXRT, FXS, FXSB, FXST, FXSTB, FXSTBI, FXSTC, FXSTD, FXSTDI, FXSTDSEI, FXSTDSE2, FXSTI, FXSTS, FXSTSB, FXSTSI, FXWVG, GE, K, KH, M2, S1, S1W, S2, S2T, S3, S3T, VRSCA, VRSCB, WL, WLA, X1, X1W, XB9R, XB9S, XB12R, XB12S, XL, XL 53C, XL 883, XL 883C, XL 883R, XL 1200C, XL 1200R, XL 1200S, XLCH, XLCR, XLH, XLH 883, XLH 1100, XLH 1200, XLR, XLS, XLT, XLX, XLX-61 and XR-1000.

The words: C.C. Rider, CCI Europe, Chrome Gear, Chrome Gear Quality Riding Gear by Custom Chrome, Chrome Specialties, Custom Chrome, Dyno Power, Inferno, Motor Factory, Premium, RevTech, Santee, Streetware For Those Who Dare, Tour Ease, The Dealers Edge, and The Edge are registered trade-marks of Global Motorsport Group, Inc., Morgan Hill, California, U.S.A.

The words: Black Diamond, Brake Max, Bullskins, CCI, Custom Chrome, Duo Seal, Dyno-Kote, Eagle Goggles, HR3, Highway One, Longneck, Low Glide Custom, Low Glide, Mirage, On Time, Pony Express, Power Ring, Pro Spark, Regency, RevPro, RevTech Pure, Speedlamp, Sport Bob, Streetware, Texas Saddles, Tribal Iron, Trim Tail and Vibra-Kushion are trademarks of Global Motorsport Group, Inc., Morgan Hill, California, U.S.A.

The Design Marks: Bullskins, C.C. Rider, CCI bar and shield, Custom Chrome, Chrome Gear Quality Riding Gear by Custom Chrome, Chrome Specialties, Dallas Premium Leather, Donnie Smith Design, Inferno, Motor Factory, Mirage, Premium, RevTech, Santee Made in U.S.A., and V-Twin Engine design are registered trademarks of Global Motorsport Group, Inc., Morgan Hill, California, U.S.A.

The Design Marks: HR3 World's Finest Bike Kits, and Streetware For Those Who Dare are trademarks of Global Motorsport Group, Inc., Morgan Hill, California, U.S.A.

All other brand names or trademarks or registered trademarks used in this catalog are the property of their respective holders.

**WARRANTY AND LIABILITY LIMITATIONS**

Except as may be expressly set forth in the product invoice, Global Motorsport Group, Inc. makes no representations or warranties as to any of its products, express or implied, including without limitation any warranties of merchantability or fitness for a particular purpose, under Section 2314 or 2315 of the California Uniform Commercial Code or otherwise.

Motorcycles can be dangerous. Global Motorsport Group, Inc. has no control over the usage of any part. Custom Chrome and Chrome Specialties expects the Dealer and the Dealer's customers to exercise good judgment as to the proper selection, installation, use and maintenance of any parts. Custom Chrome and Chrome Specialties assume no responsibility for damage or injury of any kind because of the misuse or the improper application of any parts in any way by any person.

Custom Chrome and Chrome Specialties shall not be liable for any indirect or consequential damages whatsoever.

**APPLICATION INFORMATION**

To the best of our knowledge, all of the photos and application information contained herein are accurate as of the date this catalog was approved for printing (December, 2005). Please check with your Custom Chrome or Chrome Specialties Dealer or Account Representative for verification of the latest 2005 model year applications.



This symbol appearing throughout our catalog signifies that the specified items are high-performance exhaust, carburetor, ignition or engine components and are not legal for sale or use on pollution or noise controlled motor vehicles (except those used in organized and sanctioned racing or competition events) when the installation of same would be in violation of state or federal laws or regulations governing noise or emission standards.



This symbol appearing throughout our catalog signifies that the specified items are high-performance exhaust, carburetor or engine components that are legal for sale or use in all 50 states.



This symbol appearing throughout our catalog signifies that the specified items are Harley-Davidson Original Equipment parts and are only available for purchase in the United States of America.



This symbol appearing throughout our catalog signifies that the specified items are only available for purchase from Custom Chrome Europe.



This symbol appearing throughout our catalog signifies that the manufacturer has received TÜV approval for the specified items.



This symbol appearing throughout our catalog signifies that Custom Chrome Europe has received TÜV approval for the specified items.



This symbol appearing throughout our catalog signifies that Custom Chrome Europe has received TÜV approval for some components included in kits.

© Copyright 1982-2007 by Global Motorsport Group, Inc. All rights reserved. No part of this publication may be reproduced, stored in a retrieval system, or transmitted, in any form or by any means, electronic, mechanical, photocopying, recording, or otherwise, without the prior written permission of the publisher.



World's Finest Products For Harley-Davidsons™



Custom Chrome Europe  
Planiger Strasse 154

55543 Bad Kreuznach - Germany  
[www.custom-chrome-europe.com](http://www.custom-chrome-europe.com)

[info@customchrome.de](mailto:info@customchrome.de)

Fax: +49 (0) 671 / 88888-100  
Phone: +49 (0) 671 / 88888- 0

