

Wood working machines for the craftsman and do-it-yourselfer

Main catalogue 04/2006

New

Material stand
Scroll saw
Band saw
Circular saw
Planing
Turning
Grinding
dust collectors
Accessories

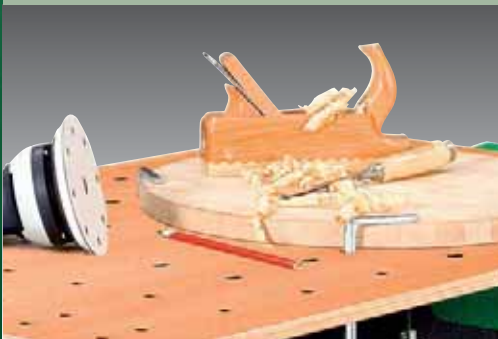

New !

For the beginners in the wood working.

HOLZSTAR offers a modern range of wood working machines for beginners to the ambitious do-it-yourselfer and craftsmen .

In this catalogue you will find machines for different applications, e.g. model making, interior fittings, cabinet making, the building site, the manufacturing of toys and handicrafts and many more.

Our target is to facilitate your working with our products in order that you will have lots of joy with the results.

Due to our specialist's networking you will find your partner on site, guarantying you an optimum advice, support and "After-Sales-Service". Of course, our advice and service team will be at your disposal at any time.

A comparison in price among really equal and comparable products will give you the certainty that it is the right way to choose a product of the HOLZSTAR range which will bare comparison with any competitive product regarding the ease of use, the equipment, the quality technique and the price-performance ratio.

www.holzstar-maschinen.de

Kilian Stürmer
Manager



All devices listed in this catalogue fulfil the legal regulations, standards and guidelines, which are valid in the European Union.



Wet-dry grinder	Page
NTS 251	4 - 7

Material stand	
UWT 3200	8 - 9

Band saws	
HBS 251	10 - 11
HBS 312-2	10 - 11
HBS 351-2	10 - 11

HBS 473	12
---------------	----

Material stand	
MS 2 R	13
MS 1 R	13
MS 1 K	13

Scroll saws	
DKS 501-1	14 - 15
DKS 501-2	14 - 15
DKS 501 Vario	14 - 15

Table circular saw	
TKS 315 Pro	16 - 17



Belt sanding machines and sand grinders	
BTS 150	18 - 19
BTS 250	18 - 19

Surface planing machine	Page
AH 150	20

Thickening machine	
DH 250	21

Surface planing and thickening machine	
ADH 260	22 - 23

Work benches	
HB 1600	24 - 25
HB 2005	24 - 25

Accessories for work benches	24 - 25
------------------------------------	---------

Shop equipment	
Tool box	26
Tool cabinet	26
Shutter cabinet	26
Folding work bench	26

Wood turning lathes	
DB 450	27

DB 900	28 - 29
DB 1100	28 - 29

Dust collectos	
SAA 1001	30
SAA 2003	30
SAA 3003	30

Accessories for suction plants	30
--------------------------------------	----



Wet-dry-grinder

HOLZSTAR NTS 251 - Universally applicable wet-dry-grinder to grind metal, glass, stones and other materials.

Arguments which will convince you:

- perfect for your home, do-it-yourselfers and craftsmen
- for wet and dry grinding
- lots of holders for different tools are available
- it can be used on the height-adjustable clip holding fixtures of other manufactures
- specially developed, water-resistant grinding wheel for a long tool-life
- due to the little speed of only 90 1/min in connection with water, no heat will be generated during the grinding process, which could affect the hardness of the tools
- lockable ON-OFF switch with emergency-stop button
- including leather stropping disk, universal holder and angle setting gauge
- easy-to-transport
- registration of design



Fig. illustrates the default scope of delivery



Fig. NTS 251 with optional rotary table

Model	NTS 251
Item No	590 2251
€ plus VAT	249,00

Technical data	
Grindstone - dimensions	max. Ø 250 x 50 mm
Stropping disk - dimensions	max. Ø 220 x 30 mm
Speed	90 1/min
Dimensions	340 x 280 x 460 mm
Engine output 50 Hz / 230 V	200 w
Net weight	16 kg



Example for application: Grinding of plane iron 90°



Example for application: Grinding of shaping iron 90°

Accessories	Item No	€ plus VAT
■ Rotary table	591 0255	49,00
■ Grindstone Ø 245 x 50 mm	591 0251	79,00
■ Leather stropping disk Ø 220 x 30 mm	591 0252	29,00

New

The optional turning table:

The optional turning table allows grinding and sharpening of the cutter edges from one side only. The grinder can simply be turned round after loosening the locking device.



Arguments which will convince you...

New



Practical, integrated drawer to store accessories and holding fixtures.

New



The holding clamp can be positioned against the cutting edge for grinding as required. The extra-wide holding clamp allows working on both disks simultaneously.

The integrated water tank:



The water tank can be easily removed for filling. Rapid and simple, without tools.

Angle setting gauge registration of design



The 3 steps to set the angles perfectly:



Step 1: Controlling and determining the cutting edge angle.



Step 2: Setting the measured cutting edge angle.



Step 3: Setting the appropriate clamp height for the cutting edge angle.



By default equipped with a lockable emergency-stop switch

New



The height of the holding clamp can be easily and precisely adjusted with a tangent screw.

Accessories NTS 251



Grinding of shaping irons 45°
(Mounting device item No 380 0015)



Grinding at an angle from 0 to 30°
(Item No 380 0038)



Grinding of cutting tools
(Mounting device item No 380 0018)



Grinding of gouges
(Item No 380 0021)



Grinding of round lames
(Item No 380 0032)



Slide rail holding device
(Item No 380 0026)



Grinding device 45°
(Item No 380 0015)



Multiple grinding device, adjustable
from 0 to 30° (Item No 380 0038)



Grinding device for axes/cutting tools, etc.
(Item No 380 0018)

Accessories	Item No	€ plus VAT
Device to grind tools 45°	380 0015	16,00
Device for axes / cutting tools, etc.	380 0018	23,50
Kit of devices for gouges	380 0021	45,00
Device for machine plane iron	380 0024	45,00
Device for knives	380 0027	28,50
Device for round lames	380 0032	12,90
Multiple grinding device, from 0 to 30°	380 0038	21,50
Slide rail for grinding device	380 0026	28,50
Trimming diamond with holding device	380 0029	52,00
Trimming grindstone rough/fine	380 0030	19,00





Grinding of axes
(Mounting device item No 380 0018)



Grinding of cutting irons
(Mounting device item No 380 0024)



Grinding unit for knives
(Item No 380 0027)



Trimming the grindstone
(Item No 380 0029)



Preparing the grindstone
(rough/fine) (Item No 380 0030)



Sliding rail for the base holder
(Item No 380 0026)



Grinding device for cutting irons
(Item No 380 0024)



Grinding device for knives
(Item No 380 0027)



Kit of devices for gouges
(Item No 380 0021)

New



Grinding device for round lames
(Item No 380 0032)



Trimming grindstone
(Item No 380 0030)



Trimming diamond and holder
(Item No 380 0029)

Material stand

HOLZSTAR Roller conveyer UWT 3200 - Universal working table and roller conveyer with quick clamping system.

Arguments, which convince you:

- universally applicable for circular cross-cut saws, belt sanding machines, cutting-out saws, etc.
- designed to guide longer workpieces
- minimum installation time
- space-saving with retractable stands
- fitting strip with rapid fixture
- height-adjustable role rests
- support arm infinitely extractable on both sides up to max. 3200 mm
- assembly and adjustment without tools
- stable aluminium steel construction
- high capability of bearing up to 225 kg



Fig. shows standard scope of delivery

Perfect to cut long workpieces into length. The retooling can be performed in a simple and easy way by quick-set clamping.

Model	UWT 3200	MS 1 K	MS 1 R	MS 2 R
Item No	590 0020	590 0004	590 0003	590 0002
€ plus VAT	169,00	39,95	36,95	22,95
Technical data				
Min./max. height of support	850 / 1000 mm	700 / 1150 mm	700 / 1150 mm	650 / 1150 mm
Max. width	3200 mm	390 mm	390 mm	285 mm
Dimensions in mm	1600 x 600 x 850	135 x 500 x 810	135 x 500 x 810	125 x 130 x 600 mm
Weight	30 kg	10 kg	10 kg	5 kg

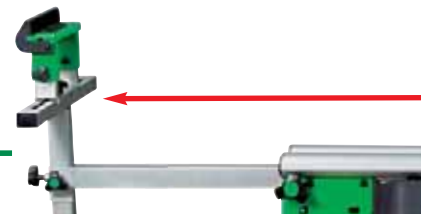

Accessories



Working place light fixture on clamping bar
Item No 590 0023, € 19,90 plus VAT



Additional clamping bar kit (2 pcs)
Item No. 590 0022, € 17,90 plus VAT



Additional roller block kit (2 pcs.)
Item No 590 0025, € 15,90 plus VAT



Vice with quick clamping
Item No 590 0024, € 29,90 plus VAT

Stand for lateral extract with clamping screw
Item No 590 0026,
€ 19,90 plus VAT



max. 3200 mm

Quick clamping



The support rail can be positioned, shifted or detached simply and easily with a quick clamping system.

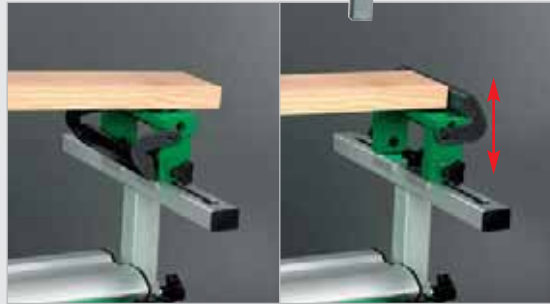

The roller blocks are equipped serially with a folding up limit stop each. Perfect for easy cutting into lengths.



The roller blocks are height- and cross adjustable. They can be extracted up to 500 mm.

Universal use

The UWT can be universally used as material stand, holding stand or work bench. A working plate made of Multiplex can be fixed simply and rapidly on the clamping bars.



Optionally available:
Working plate 140 x 80 cm
Multiplex/ beech 19 mm
Item No 590 0019;
€ 299,- plus VAT



Perfect as a support to cut long workpieces into lengths. (the illustration shows a metal coping saw)

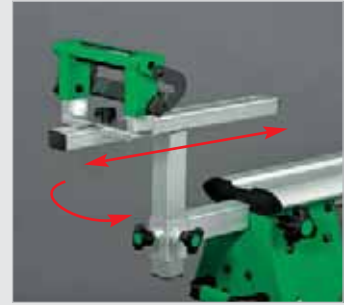

The roller block holding shackle can also be used in turned position.



Example for application as a supply aid for thicknessing machines.



Three integrated 230 V sockets on the operator's side.

Optional



Vice with quick clamping to fix workpieces.
Item No 590 0024, € 29,90 plus VAT

Optional



Use of clamping bars as additional roller blocks. Further clamping bars or roller blocks are available as accessories.



The integrated depository for keys, screws, etc.

Foldaway space-saving for transport and storage.

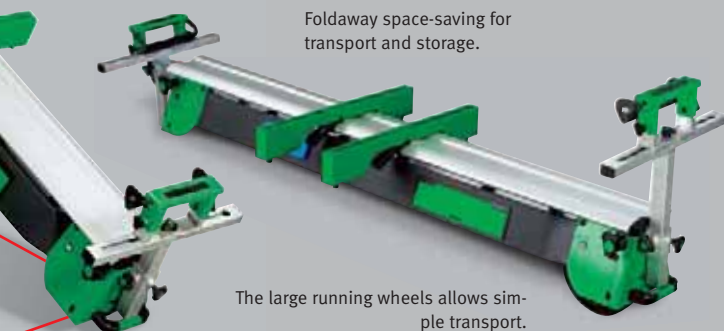

The large running wheels allows simple transport.



MS 1 K
with ball support e.g. for plates. Also allows lateral moves.

MS 1 R
with role support. Universally applicable.

MS 2 R
with role support. Small type.

Band saws

HOLZSTAR band saws HBS 251, HBS 312-2, HBS 351-2

Compact band saws of professional type for the demanding model maker and do-it-yourselfer.

Arguments which will convince you:

- wrap-resistant welding construction
- safe saw cuts in wood, plastic material and NE metal which do not run off centre
- aluminium longitudinal stop with excenter quick clamping and scale
- precise sawing table made of grey cast iron with grinded surface, inclinable from 0-45° with scale
- precise 3-roller saw band guide, serial top and bottom
- flywheels running precisely on bearings made of aluminium diecast with special leggings for higher lifetime of the saw band
- high-performance motor
- the machine is switched off via a safety switch when opening the gate and additionally unintended starting-up is being avoided.



HBS 251 of standard type with optional angular stop



HBS 351-2 of standard type with optional angular stop



HBS 312-2 with optional angular stop and stand



Model	HBS 251	HBS 312-2	HBS 351-2
Item No	590 0251	590 0331	590 0351
€ plus VAT	219,00	399,00	469,00
Technical data			
Max. cutting width	245 mm	305 mm	345 mm
Max. cutting height	120 mm	180 mm	200 mm
Cutting speed	11,6 m/sec.	6,2/13,3 m/sec.	7,3/15 m/sec.
Saw blade length	1790 mm	2240 mm	2490 mm
Table size	290 x 290 mm	480 x 400 mm	548 x 400 mm
Motor power 50 Hz	350 W / 230 V	750 W / 230 V	1000 W / 230 V
Dimensions	420 x 330 x 880 mm	465 x 360 x 1060 mm	520 x 380 x 1155 mm
Net weight	32 kg	65 kg	70 kg

Angular stop HBS 251

Angular stop HBS 312-2 / HBS 351-2

Accessories	Item No	€ plus VAT
Angular stop for HBS 251	591 0810	19,90
Angular stop for HBS 312-2 / HBS 351-2	591 0814	24,90
Stand for HBS 251	591 0813	29,90
Stand for HBS 312-2	591 0811	39,90
Stand for HBS 351-2	591 0812	39,90



HBS 312-2 interior- and rear view with inclined saw table.

Standard type:

- incl. saw band
- aluminium parallel stop



Saw bands for HBS 251	Quality	Item No	€ plus VAT
6,0 x 0,36 x 1790 mm / 6 tpi* for wood - curve cut	Swedish steel	516 2506	14,90
12,0 x 0,36 x 1790 mm / 6 tpi* for wood - straight cuts	Swedish steel	516 2512	14,90
3,0 x 0,65 x 1790 mm / 14 tpi* for plastic material, NE metals	Alloy	516 3203	13,90
6,0 x 0,65 x 1790 mm / 14 tpi* for plastic material, NE metals	Alloy	516 3206	13,90
Saw bands for HBS 312-2			
6,0 x 0,5 x 2240 mm / 4 tpi* for wood - curve cuts	Swedish steel	516 3106	17,90
12,0 x 0,5 x 2240 mm / 5 tpi* for wood - straight cuts	Swedish steel	516 3112	17,90
15,0 x 0,5 x 2240 mm / 5 tpi* for wood - straight cuts	Swedish steel	516 3115	17,90
3,0 x 0,65 x 2240 mm / 14 tpi* for plastic material, NE metals	Alloy	516 3213	16,90
6,0 x 0,65 x 2240 mm / 14 tpi* for plastic material, NE metals	Alloy	516 3216	16,90
Saw bands for HBS 351-2			
6,0 x 0,5 x 2490 mm / 4 tpi* for wood - curve cuts	Swedish steel	516 3706	18,90
12,0 x 0,5 x 2490 mm / 5 tpi* for wood - straight cuts	Swedish steel	516 3712	18,90
15,0 x 0,5 x 2490 mm / 5 tpi* for wood - straight cuts	Swedish steel	516 3715	18,90
3,0 x 0,65 x 2490 mm / 14 tpi* for plastic material, NE metals	Alloy	516 3223	17,90
6,0 x 0,65 x 2490 mm / 14 tpi* for plastic material, NE metals	Alloy	516 3226	17,90

*teeth per inch

Arguments which will convince you...



A 3-roller saw band guide top and bottom with little friction, precise and easily adjustable.



The aluminium parallel stop with excenter quick clamping can be shifted easily and precisely. The pre-set value can be read off easily by means of an integrated magnifying lens together with a millimetre scale



The 2-level speed adjustment is performed manually by simple displacing the belt on the HBS312-2 and HBS351-2. A chip brush provides for free running surfaces of the driving wheels.



The grey cast iron saw table is positioned on balance seat. The table inclination can be set infinitely from 0-45°. A scale shows set inclination degree.

HOLZSTAR band saw HBS 473

Large band saw of professional type for the do-i-yourselfer and craftsman.

Arguments which will convince you:

- wrap-resistant housing made of steel plate
- safe saw cuts in wood, plastic material and NE metal which do not run off centre
- simple and rapid relaxing of the saw band with an excenter rapid clamping lever, it is not necessary to change the basic settings of the tension
- serial with two cutting speeds
- Cast table, inclinable up to 45°
- serial aluminium longitudinal stop
- when opening the gate, the machine will be switched off by a safety switch which also prevents from unintended starting-up



Arguments which will convince you...



The aluminium parallel stop with excenter quick clamping can be shifted easily and precisely. Easy readable millimetre scale with integrated magnifying lens.



Precision 3-roller band saw blade guide serial top and bottom. Little friction, precise and easily adjustable.



Integrated display of the saw band tension for the different saw blade widths. Readable from outside through a sight window which is integrated into the gate.

Model	HBS 473
Item No	590 0473
€ plus VAT	1.149,00

Technical data	
Max. cutting width	465 mm
Max. cutting height	285 mm
Cutting speed	460 / 980 m/min.
Saw blade length	3455 mm
Precision guide	top/bottom
Table size	535 x 485 mm
Saw table inclination	-10° - +45°
Engine power 50 Hz	1,5 kW / 400 V
Dimensions	2000 x 800 x 490 mm
Net weight	146 kg

Accessories	Quality	Item No	€ plus VAT
Angular stop HBS 473		591 0814	24,90
Saw bands HBS 473 for wood			
6,0 x 0,5 x 3455 mm / 4 tpi* curve cuts	SWS*	516 3806	27,90
10,0 x 0,5 x 3455 mm / 5 tpi* straight cuts	SWS*	516 3810	27,90
15,0 x 0,5 x 3455 mm / 5 tpi* straight cuts	SWS*	516 3815	27,90
20,0 x 0,5 x 3455 mm / 6 tpi* straight cuts	SWS*	516 3820	32,90
25,0 x 0,5 x 3455 mm / 6 tpi* straight cuts	SWS*	516 3825	37,90
Saw bands HBS 473 for plastic material, NE metals			
3,0 x 0,65 x 3455 mm / 14 tpi*	Alloy	516 3233	19,90
6,0 x 0,65 x 3455 mm / 14 tpi*	Alloy	516 3236	19,90

*teeth per inch; Swedish steel



HOLZSTAR Material stand MS 1 R, MS 2 R and MS 2 K

Stable helpers in the shop. Foldaway space-saving.

Arguments which will convince you:

- universally applicable for band saws, circular saws, wood working machines
- perfect to support long, bulky or heavy workpieces for feed and removal
- foldable type, this way specially space-saving and easy-to-transport
- infinitely height-adjustable
- stable galvanized steel roles

Universally
applicable
foldaway
space-saving



MS 1 K

with ball support for e.g. plates. Also allows lateral moves



MS 1 R

with role support.
Universally applicable.



MS 2 R

with role support.
Small type.

Model	MS 1 K	MS 1 R	MS 2 R
Item No	590 0004	590 0003	590 0002
€ plus VAT	39,95	36,95	22,95
Technical data			
Width of support	390 mm	390 mm	285 mm
Min./max. height	700 / 1150 mm	700 / 1150 mm	650 / 1150 mm
Dimensions	135 x 500 x 810 mm	135 x 500 x 810 mm	125 x 130 x 600 mm
Net weight	10 kg	10 kg	5 kg



Scroll saws

HOLZSTAR scroll saw DKS 501-1, DKS 501-2 and DKS 501 Vario - perfect for all craft work model making and other miter saw working. Vario type with infinitely variable adjustment of strokes.

Arguments which will convince you:

- universally applicable for mold making, precision mechanic, model making, manufacturing of toys, designers, architects, schools, apprentice shops, craftsmen and do-it-yourselfers
- to work soft woods (< 50 mm), plastic materials (< 30 mm) or NE metals (< 10 mm) or similar materials
- the large throat of 406 mm also allows working of large workpieces
- the robust cast construction guarantees smooth and vibration-free running
- the integrated adjustable dust blower device removes dust particles of the cutting line when sawing
- saw blade quick-action system allows the rapid changing of saw blade
- the transparent saw blade protection provides for optimum safety and can be adjusted individually
- cast table inclinable from -45° to +15° with angular scale for miter cuts
- integrated suck off nozzle
- Vario type with infinitely variable number of strokes from 400-1600 1/min.
- compact size therewith applicable for any work bench or working surface



DKS 501 Vario



DKS 501 Vario



Model	DKS 501-1	DKS 501-2	DKS 501 Vario
Item No	590 0501	590 0502	590 0500
€ plus VAT	99,00	119,00	149,00

Technical data			
Max. cutting depth	50 mm	50 mm	50 mm
Throat	406 mm	406 mm	406 mm
Length of saw blade	133 mm	133 mm	133 mm
Number of strokes	1440 /min	920/1440 /min	400-1600 /min
Table size	380 x 250 mm	380 x 250 mm	380 x 250 mm
Engine power	125 W / 230 V	125 W / 230 V	125 W / 230 V
Dimensions mm	600 x 300 x 310	600 x 300 x 310	600 x 300 x 310
Suck off nozzle- Ø	mm	mm	mm
Net weight	13 kg	13 kg	13 kg



Perfect to work at a millimetre range. Due to the saw blade quick-action system the changing from outside cuts to inside cuts can be performed within seconds. The serial dust blowing device with a flexible hose provides for free view onto the cutting line.

Scroll saws

of different types with one-, two speed drive and infinitely variable adjustment of strokes

The saw blade guide is also height-adjustable and can therefore be adapted individually to any workpiece. Therewith maximum safety for the user can be guaranteed.

The transparent saw blade protection is height-adjustable and provides for an optimum protection as well as for free view. The saw blade is completely protected. The saw blade guide is also height-adjustable.



Vario type with infinitely variable adjustment of strokes with a turning knob at the front of the machine. With integrated suck off nozzle to be connected to an external suction plant.

Arguments which will convince you...



The large planed cast table can be inclined from -45° to +15°. The set inclination can be read off the scale.



The saw blade can be changed in a few seconds by means of a quick-action lever without changing the basic settings of the saw blade tension.



Freely oscillating saw blade seat for standard saw blades with cross pin.



Different types of the scroll saw DKS 501 are available. The illustration here shows the switch of the DKS 501-2 with two speeds for the lift of stroke.



Saw blade	t/cm	pu	Item No	€ plus VAT
1) for wood, plastic material, gypsum 3,0 x 0,25 mm	10	6 pcs.	591 1628	6,90/pack
2) for wood 6,0 x 0,40 mm	6	6 pcs.	591 1660	6,90/pack
3) for metal 6,0 x 0,40 mm	12	6 pcs.	591 1661	6,90/pack

Scope of delivery:
1 saw blade 3,0 x 0,25 mm (10) for wood, plastic material and gypsum

Circular saw benches

HOLZSTAR circular saw bench TKS 315 Pro

Universally applicable for completion of the interior, furniture construction or as a circular saw on construction sites.

Arguments which will convince you:

- largely dimensioned machine table made of steel, serially galvanized against corrosion
- serial with ball bearing carriage and limit stop for miter stop (adjustable from -45° to +45°)
- the serial cable elongation can also be mounted at the right as a table broadening
- saw blade turning from 0-45°, precise, exact to degree and easily adjustable over the handwheel and scale
- The saw blade height adjustment is also performed over handwheel at the user front
- large aluminium parallel stop with excenter quick gripping
- high-performance industrial motor with brake appropriate for continuous operation
- thanks to the high-performance motor you can also easily work hard wood
- incl. saw blade hood with integrated suck off connection
- large central suck off connection Ø 100 mm
- incl. HM saw blade Ø 315 mm / 36 Z
- easy movable due to serial rollers and foldaway transport handles
- lockable switch plug combination



TKS 315 Pro (400 V)
Illustration with serial cable elongation, sliding carriage with miter stop and two aluminium limit stops



The foldaway feet and the quick-action screws allow rapid folding without tools for the transport or space-saving storage of the machine.

Model	TKS 315 Pro
Item No (230 V)	590 3251
€ plus VAT	449,00
Item No (400 V)	590 3253
€ plus VAT	449,00
Technical data	
Max. saw blade-Ø	315 mm
Max. cutting height 90°/45°	90/50 mm
Saw blade inclination	0-45°
Table dimensions	800 x 550 mm
Table height	810 mm
Speed	2800 min ⁻¹
Engine power 50 Hz	(230V) 2,2 kW / (400V) 2,8 kW
Dimensions	2000 x 1360 x 1000 mm
Net weight	44 kg



The serial rollers together with the foldaway transport handles allow easy and rapid moving of the machine.



Sliding carriage with miter limit stop adjustable from -45° to +45° with quick clamping lever



The parallel limit stop allows to edge-plane boards, separating cuts, chamfer and angular cuts



TKS 315 Pro (400 V)
with optional table broadening



Accessories	Item No	€ plus VAT
Cutting replacement circular saw blade 28 teeth, Ø 315 mm	526 3128	39,00
Additional table broadening at the right	591 3251	39,00
Aluminium profile for miter stop	591 0315	9,95

Scope of delivery:

- Sliding carriage
- Rollers
- Table elongation
- Parallel limit stop
- Saw blade protective hood with hose

Arguments which will convince you...



Parallel limit stop with excenter quick gripping, precise and easily adjustable with the scale.



The saw unit is easily slewable with a handwheel from 0 to 45°



Precise and easy-running height adjustment and inclination of the saw unit with easy-t-handle handwheels. The stable suspension of the saw unit at the front and rear allows precise cuts.



Lockable switch-plug combination with emergency-stop button. TKS 315 Pro is available with 230 volts or 400 volts.

Belt sanding machine and disc sander

HOLZSTAR belt sanding machine and disc sander BTS 150 and BTS 250 - universally applicable for deburring, surface and contour grinding. Perfect for the model maker and do-it-yourselfer.

Arguments which will convince you:

- appropriate for all materials and shapes
- twist-free machine housing made of a steel grey cast iron construction
- sanding belt unit infinitely inclinable from 0 to 90°, it can be used horizontally and vertically
- double controlled, slewable working table infinitely variable from 0-45°
- rapid and simple replacement of the sanding belt with the quick-action device, tools are not required for the assembly
- integrated suck off nozzle to be connected to an external suction plant
- incl. sanding belt and grinding wheel



BTS 150
with serial miter stop

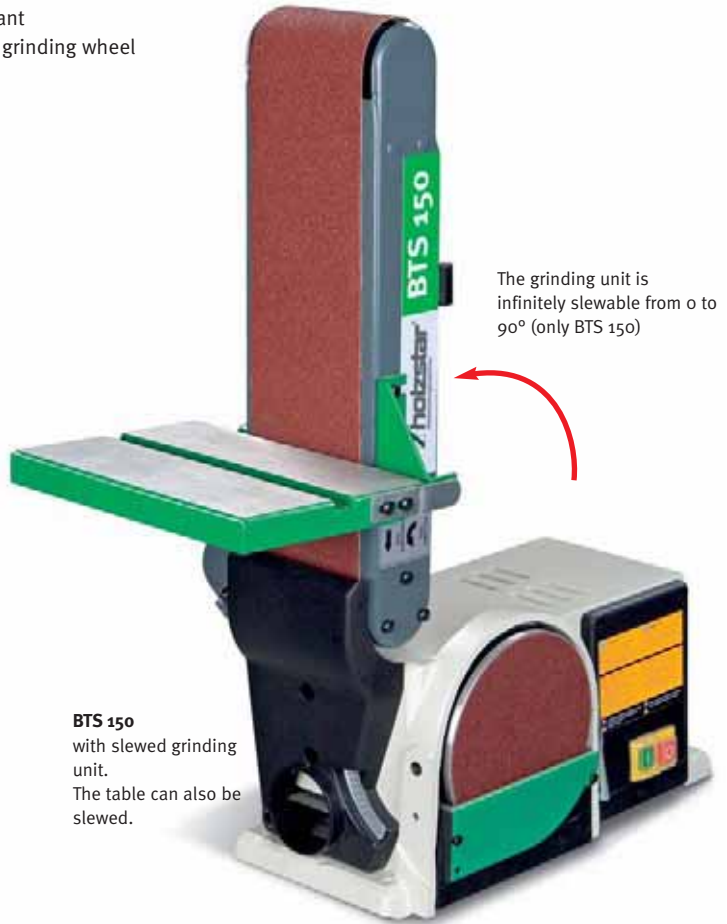

BTS 150
with slewed grinding unit.
The table can also be slewed.

The grinding unit is infinitely slewable from 0 to 90° (only BTS 150)



To grind longitudinal edges, entering edges, curves, miters as well as plane surfaces at a right angle. To work soft and hard wood.

Model	BTS 150	BTS 250
Item No	590 4150	590 4250
€ plus VAT	129,00	349,00
Technical data		
Sanding band size	915 x 100 mm	1220 x 150 mm
Disc size	150 mm	250 mm
Table size	150 x 230 mm	360 x 200 mm
Speed	2.850 r/min.	1.440 r/min.
Dimensions	560 x 270 x 300 mm	720 x 410 x 440 mm
Engine power 50 Hz	250 W / 230 V	800 W / 230 V
Net weight	17 kg	47 kg



Large grinding disc to grind curves and radiuses.

The BTS 250 is equipped with a large aluminium working table. The working tables are be laterally controlled for higher stability.

The serial limit stop can be used for grinding with slewed grinding unit as a grinding table.

The replacement of the sanding belt is performed rapid and easy with the quick gripping system.

The BTS 250 is additionally equipped with handy handles.

BTS 250
with optional substructure
(Item No. 591 4250)

Arguments which will convince you...



The stable working table is slewable from 0 to 45°. The preset slewing can be read off a scale.



The grinding tables of the BTS 150 and BTS 250 are being laterally controlled to provide a higher stability.



With an integrated suck off nozzle to connect it to an external suction plant



BTS 250 with lockable emergency-stop to prevent it from unauthorised use.

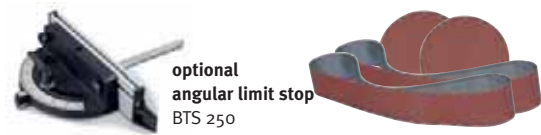

optional
angular limit stop
BTS 250

Accessories	Item No	PU	€ plus VAT
Substructure for BTS 250	591 4250		47,50
Angular stop for BTS 250	591 0814		24,90
Sanding belts BTS 250 (1.220 x 150 mm)			
- grind 60	591 1206 (PU 10)		4,90 / pcs.
- grind 80	591 1208 (PU 10)		4,90 / pcs.
- grind 100	591 1210 (PU 10)		4,90 / pcs.
- grind 120	591 1212 (PU 10)		4,90 / pcs.
- grind 180	591 1218 (PU 10)		4,90 / pcs.
Grinding disc and Velcro seat BTS 250			
- grind 60 Velcro	591 2506 (PU 10)		1,10 / pcs.
- grind 80 Velcro	591 2508 (PU 10)		1,10 / pcs.
- grind 100 Velcro	591 2510 (PU 10)		1,10 / pcs.
- grind 120 Velcro	591 2512 (PU 10)		1,10 / pcs.
- grind 150 Velcro	591 2515 (PU 10)		1,10 / pcs.
- Velcro seat	591 2501		7,40

Accessories	Item No	VPE	€ plus VAT
Sanding belts BTS 150 (915 x 100 mm)			
- grind 60	591 1006 (PU 10)		2,90 / pcs.
- grind 80	591 1008 (PU 10)		2,90 / pcs.
- grind 100	591 1010 (PU 10)		2,90 / pcs.
- grind 120	591 1012 (PU 10)		2,90 / pcs.
- grind 150	591 1015 (PU 10)		2,90 / pcs.
Grinding disc and Velcro seat BTS 150			
- grind 60 Velcro	591 1506 (PU 10)		0,99 / pcs.
- grind 80 Velcro	591 1508 (PU 10)		0,99 / pcs.
- grind 100 Velcro	591 1510 (PU 10)		0,99 / pcs.
- grind 120 Velcro	591 1512 (PU 10)		0,99 / pcs.
- grind 150 Velcro	591 1515 (PU 10)		0,99 / pcs.
- Velcro seat	591 1001		2,99

HOLZSTAR surface planing machine AH 150 - compact surface planing machine, universally applicable in the shop or on the construction site.

Arguments which will convince you:

- perfect for the do-it-yourselfer and for the hobbyist
- to dress massive wood, blanks, small boards and ledges
- to manufacture plane surfaces, rectangular or angular
- easily applicable at any place, e.g. to chamfer
- for exact, angular dressing of raw workpieces and woods
- simple and precise adjusting of the chipping of up to 3 mm
- cutter spindle with 2 HSS cutting knives
- easy adjustable aluminium dressing limit stop, inclinable from -45° to +45°
- large working tables (700 x 155 mm) made of highly ripped aluminium diecasting
- adjustable protective cover for grinding spindle
- high-performance 230 volt motor
- integrated suck off nozzle for chips
- lockable emergency-stop button



Model	AH 150
Item No	590 3150
€ plus VAT	199,00

Technical data	
Dimensions of working table	156 x 700 mm
Planing width	156 mm
Max. chipping	3 mm
Length of working table	330 mm
Planing spindle-Ø	50 mm
Number of cutting knives	2
Speed	9000 1/min
Inclination of the limit stop	-45° - +45°
Engine power 50 Hz	1280 W / 230 V
Dimensions	700 x 330 x 205 mm
Weight	18 kg

Scope of delivery:

- Surface planing limit stop
- Cover for planing shafts
- 2 sliding guides
- Setting gauge for cutting knives

Accessories	Item No	€ plus VAT
Spare cutting knife	591 3150	19,50

Arguments which will convince you...



The aluminium dressing limit stop is laterally inclinable by 45°. The preset inclination can easily be read off the scale.



The adjustment of the chipping is performed with the setscrew below the dressing table. The set chipping height can be read off the scale.



The adjustment of the cutting knife is performed with the included setting gauge for cutting knives.



The protective cover for the planing shaft can be variably adjusted in height and width.

HOLZSTAR thicknessing machine DH 250

Compact, portable thicknessing machine for the do-i-yourselfer and craftsmen

Arguments which will convince you:

- perfect for exact planing of soft wood, massive wood, boards, planks and ledges
- portable, this way applicable at any place
- grinded working table made of steel
- foldaway table elongation with roles, this way, space-saving storage
- easy and precise height-adjustment of the planing unit with a crank and scale
- cutter shaft with 2 HSS cutting knives
- quadruple planing unit run on bearings
- automatic workpiece advance (8 m/min.)
- one each rubberised auger and extraction roller for gentle workpiece advance
- chipping adjustable of up to 2,5 mm
- powerful 230 volt motor with 1,5 kW
- integrated chip suck off hood
- easy transport due to integrated recessed grips



Model	DH 250
Item No	590 3250
€ plus VAT	339,00
Technical data	
Min. planing length	127 mm
Max. planing width	254 mm
Min./max. working height	7/153 mm
Max. chipping	2,5 mm
Advance speed	8 m/min
Cutter shaft-Ø	50 mm
Number of cutters	2
Speed	8000 1/min
Engine power 50 Hz	230 V/1,5 kW
Dimensions	580 x 558 x 463 mm
Weight	30 kg



Accessories	Item No	€ plus VAT
Spare cutting knife	591 3250	29,50

Arguments which will convince you...



The planing unit can be adjusted exactly to the required height with a crank together with a millimetre scale at the front of the machine.



Connection to an external suction plant with the integrated suck off nozzle.



The cutting knives are adjusted with the setting gauge for cutting knives which is included in the delivery.



ON/OFF switch with dust cap and low-voltage protection.

Combination of a surface planing and thicknessing machine

HOLZSTAR surface planing thicknessing machine ADH 260

With a planing width of 260 mm and including substructure.

Arguments which will convince you:

- space saving, perfect for the ambitious do-it-yourselfer and hobbyist
- for dressing of massive wood, boards, planks and ledges
- thicknessing machine for exact, angular planing of smooth surfaces
- simple and precise adjustment of the chipping of up to 3,0 mm
- automatic workpiece advance (5 m/min.)
- toothed steel draw-in roller for even and constant taking-in of the wood
- a rubberised pull-out roller protects the surface when thicknessing
- easy adjustable aluminium dressing limit stop, inclinable from 90° to +45°
- largely dimensioned dressing tables made of ripped aluminium diecast
- cutter shaft with 2 HSS cutting knives
- large thicknessing table made of grey cast iron with grinded surface, quadruple running on bearings
- lockable emergency-stop
- powerful 230 volt motor with 2,0 kW
- integrated, repluggable chip suction hood



ADH 260
Standard type
with rollers

Model	ADH 260
Item No	590 3260
€ plus VAT	769,00
Technical data	
Dimensions dressing table	1030 x 280 mm
Thicknessing table dimensions	260 x 400 mm
Max. working width	260 mm
Max. chipping	3 mm
Cutter spindle-Ø	63 mm
Number of cutting knives	2
Speed of planing shaft	6.500 1/min
Advance speed	5 m/min.
Speed	2.800 1/min
Engine power 50 Hz	2,0 kW / 230 V
Weight	66 kg



The serial rollers with two steering rollers allow easy transport. To move the machine simply step on the roller bow by which the rollers are pushed downward. With a spring clip the rollers return to normal position.

The table height-adjustment is simply and easily performed with a crank.

The repluggable suction hood is used for dressing and thickening.



ADH 260
retooled for
thicknessing



Recommendation of Accessories -
HOLZSTAR
Material stand

Accessories	Item No	€ plus VAT
Spare cutting knife PU 2 pcs.	591 3260	27,90

Arguments which will convince you...



The draw-in rollers running on springs prevent from formation of prints on the wood. The thickening table is guided on four columns.



Automatic, even advance with return stroke protection. The toothed draw-in roller allows to draw-in the wood constantly.

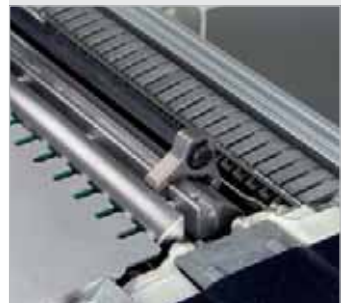

The adjustment of the cutting knife is performed with the setting gauge for cutting knives.



The aluminium dressing limit stop can be inclined by 45°. The set inclination can easily read of a scale.

Original HOLZKRAFT® joiner's benches for craftsmen HB 1600 / HB 2005

Professional type

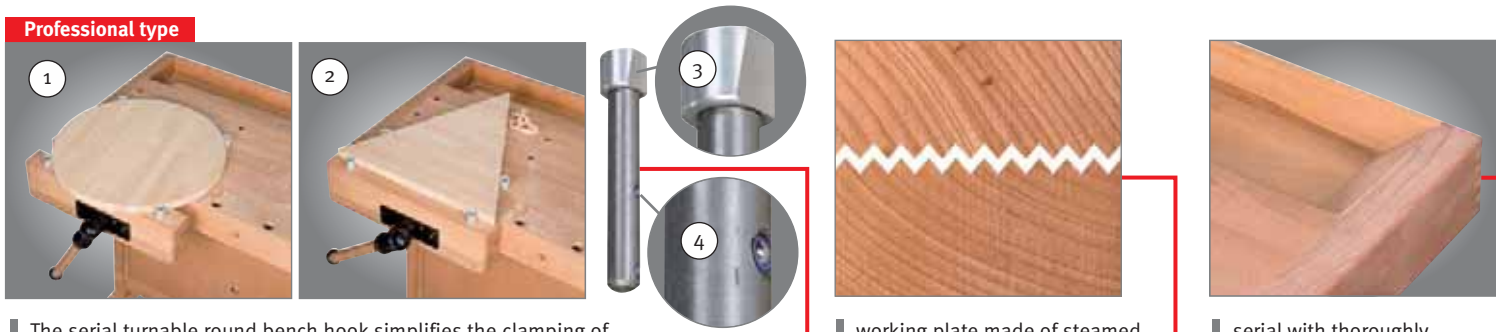

- The serial turnable round bench hook simplifies the clamping of different types of workpieces (illustration 1 + 2).
- The grip holders are made of aluminium. This prevents from damaging your workpieces in case of accidental touching.
- The lateral inclined clamping surface of the round holders press the workpiece uniformly downward towards the working plate when clamping (illustration 3).
- With the adjustable pressure elements (4) the round bench hooks can be positioned at different heights.

■ working plate made of steamed massive beech wood with toothed glueing for best possible solidity of the wood bonding

■ serial with thoroughly processed tool drawer, all important edges are rounded
 ■ the surface is oiled environmental-friendly

Professional type



■ as wood is working in different ways a shrinking groove at this position will prevent from pressing off the bench hook ledge (HB 2005)

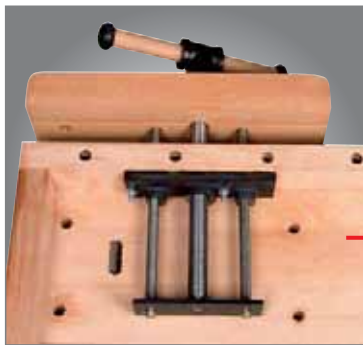

- French front and rear tongs for HB 1600
- French front tongs (and German rear tongs) for HB 2005
- two cylinder rods are guided precisely and stable in a heavy cast part parallelly
- with easy-running, largely-dimensioned trapezoidal thread spindle



- HB 2005 with serial equipment
- pedestal without joints with screwed follow-up threaded rods
- notches mountable on 2 different heights for the installation of optional substructure cabinets

Standard type



- HB 1600 serial with standard storage shelf

Professional type



- HB 2005 with optionally mounted tiltable drawer



- kit of wheel chocks HB 2005 for 94 cm working height; Item No 510 2113; € 28,90 plus VAT / pair

Model	HB 1600
Item No	510 1160
€ plus VAT	425,00
Technical data	
Length	1600 mm
Width	600 mm
Thickness of plate	30 mm
Working height	820 mm
Weight	80 kg
Scope of delivery	2 bench hooks 1 drawer

Model	HB 2005
Item No	510 2005
€ plus VAT	649,00
Technical data	
Length	2000 mm
Width	650 mm
Thickness of plate	110/50 mm
Working height	820 mm
Weight	125 kg
Scope of delivery	2 short and long each 1 drawer

Professional type



■ additional bench hook holes for HB 2005 at the front side for further clamping options (fig. with optional bench aid)

NEW



■ German rear tongs (only for HB 2005)
 ■ with new clearance-free adjustable guide made of steel on U-shaped steel profiles
 ■ with easy-running trapezoidal thread spindle



NEW !
 + improved type
 + round bench hooks
 + all important edges rounded
 + round bench hook holes at the front side
 + optional accessories
 + surface oiled environmental-friendly

Professional accessories



■ Option "tilted drawer" serial with tool holder.

Accessories	Item No	€ plus VAT
■ Front tongs HB 2005	052 5005	129,00
■ Rear tongs HB 2005	052 5006	145,00
■ Round bench hook kit long	052 5007	59,00
■ Round bench hook kit short	052 5010	39,00
■ Wrench for tongs HB 2005	052 5013	19,00
■ Front/Rear tongs HB 1600	052 5012	75,00
■ Wrench for tongs HB 1600	052 5011	19,00

■ Bench aid Item No 510 1190; € 39,00 plus VAT

Optional accessories



■ Storage shelf to be inserted in the pedestal of the HB 2005
 Dimensions: 1195 x 480 mm Item No 510 2117; € 45,00 plus VAT



■ Drawer cabinet with 3 drawers appropriate for HB 2005, lockable, Dimensions: 740 x 450 x 480 mm Item No 510 2111; € 189,00 plus VAT



■ Built-in cupboard, 4 drawers, 2 doors for HB 2005, lockable, Dimensions: 1195 x 460 x 480 mm Item No 510 2116; € 199,00 plus VAT



■ Tilted drawer with tool holders appropriate for HB 2005, lockable, Dimensions: 1195 x 450 x 480 mm Item No 510 2110; € 295,00 plus VAT



■ Bench aid for assembly on HB 2005; Item No 510 2112; € 29,00 plus VAT

HOLZKRAFT assembly toolbox - made of robust Multiplex plates for the daily use on construction sites.

- perfect for construction sites as an assembly toolbox; also applicable as tool cupboard
- space-saving well arranged tool storage
- easy-to-transport with transport rollers and extractable handle
- can also be moved open as both rollers are fixed to the body
- with two drawers
- lockable

Technical data

- Length: 650
- Width: 330
- Height: 400
- Material: Multiplex
- Weight: 13 kg

Toolbox

Selling price plus VAT

229,-

Item No 510 1300



NEW
Now with rollers & handy handle



HOLZKRAFT tool cupboard

- space-saving, well arranged tool storage
- stable type, body made of massive beech wood
- doors made of beech scale board
- with two extractable drawers
- lockable

Tool cupboard

Selling price plus VAT

229,-

Item No 510 1200

Technical data

- Length: 700 mm
- Width: 250 mm
- Height: 830 mm
- Material: beech wood



Fig. with a sample of tool set components

HOLZKRAFT shutter cabinet -

universally applicable.

- easy movable with largely-dimensioned running wheels and 2 steering rollers
- working plate made of massive dammed beech (red beech), toothed glueing
- 1 drawer with limit stop
- lockable

NEW

Technical data for shutter cabinet

- Depth of working plate: 690 mm
- Width of working plate: 800 mm
- Thickness of working plate: 40 mm
- Working height: 950 mm
- Inner dimensions of drawer: 580 x 90 mm



Shutter cabinet

Selling price plus VAT

429,-

Item No 510 2114

Foldaway work bench KWB 1000

- rapid and simple assembly and disassembly due to toggle catch
- foldaway, this way, only little space is required
- stable and firm steel tube frame
- non-splintering due to circumferential edge protection
- surface-treated and coated

Technical data for KWB 1000

- Depth of working plate: 700 mm
- Width of working plate: 1000 mm
- Thickness of working plate: 30 mm
- Working height: 830 mm
- Weight: 36 kg



KWB 1000

Selling price plus VAT

219,-

Item No 390 0030

HOLZSTAR small wood turning lathe DB 450

Compact type for the hobbyist and for the professional.

Arguments which will convince you:

- the twist-free grey cast iron engine bed provides for high smoothness of running and accuracy
- tailstock and spindle stock are also made of stable grey cast iron
- incl. easy-to-adjust tool rest
- optional with a distance between centres of 1000 mm
- tailstock (lift 50 mm) - serial with follow lathe centre
- tailstock spindle sleeve with a hole to machine long workpieces
- speed adjustment, 4 speeds with V-belt
- very quiet and smooth running

Very quiet !

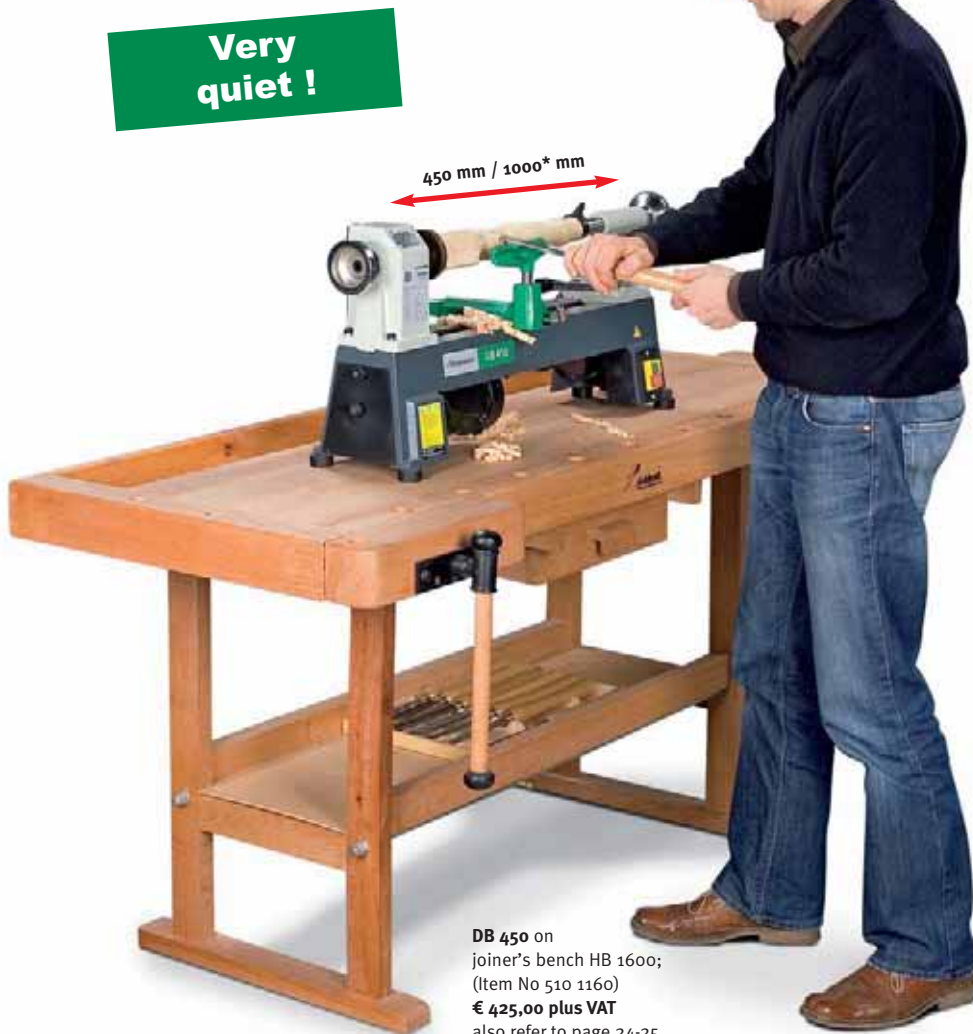

DB 450 on joiner's bench HB 1600; (Item No 510 1160)
€ 425,00 plus VAT
also refer to page 24-25

Arguments which will convince you...



With window on the V-belt pulley to control the selected speed. Easy shifting of the V-belt with the chuck lever.



The tailstock made of grey cast iron is rapidly and easily fixed with a clamping lever. The adjustment of the centre sleeve is performed with a handwheel.



8-piece turning chisel kit (Item No 593 1011)
€ 69,00 plus VAT

Model	DB 450
Item No	592 0450
€ plus VAT	199,00
Technical data	
Max. turning-Ø	254 mm
Bed height	127 mm
Distance between centres	450 / 1000* mm
Spindle head thread	1" x 8 TPI
Speed	500-3150 1/min
Speed levels	4
Engine power 50 Hz	370 W / 230 V
Morse cone	MT 2
Dimensions	820 x 300 x 430 mm
Weight	38 kg

* optional with bed elongation accessory Item No 592 0451

CE built according to CE guidelines



DB 450 with standard equipment



DB 450 with optional bed elongation (Item No 592 0451) for distance between centres of 1000 mm,
€ 59,00 plus VAT

Wood turning lathes

HOLZSTAR wood turning lathes DB 900 and DB 1100

Wood turning lathes with variable speed regulation for the hobbyist and for the professional.

Arguments which will convince you:

- the twist-free greycast iron engine bed provides for high smoothness in running and accuracy
- tailstock and spindle stock are also made of stable grey cast iron
- wide, easy-to-adjust tool rest
- tailstock with quick-action lever and handwheel
- tailstock (lift 50 mm) serial with follow lathe centre
- tailstock centre sleeve with a hole to machine long workpieces
- variable speed regulation from 500 to 2000 1/min. with digital speed display
- the tailstock is slewable at 180°
- perfect for turning of large diameters
- lockable emergency-stop



DB 900
Serial equipment



DB 1100
Serial equipment



Optional copying equipment
for DB 900 and DB 1100

Model	DB 900	DB 1100
Item No	592 0900	592 1100
€ plus VAT	349,00	499,00
Technical data		
Max. turning-Ø	306 mm	358 mm
Bed height	153 mm	179 mm
Distance between centres	900 mm	1100 mm
Spindle head thread	1" x 8 TPI	1" x 8 TPI
Speeds	500 - 2000 1/min	500 - 2000 1/min
Speed levels	variable, 10 levels	variable, 10 levels
Engine power 50 Hz	550 W / 1~ 50 Hz	750 W / 1~ 50 Hz
Morse cone	MT 2	MT 2
Dimensions	1380 x 330 x 370 mm	1620 x 340 x 430 mm
Weight	80 kg	92 kg

Scope of delivery DB 900

- Face plate Ø 15 cm
- follow tailstock centre
- Machine substructure
- Quadruple face dog

Scope of delivery DB 1100

- Face plate Ø 15 cm
- follow tailstock centre
- Machine substructure
- Quadruple face dog

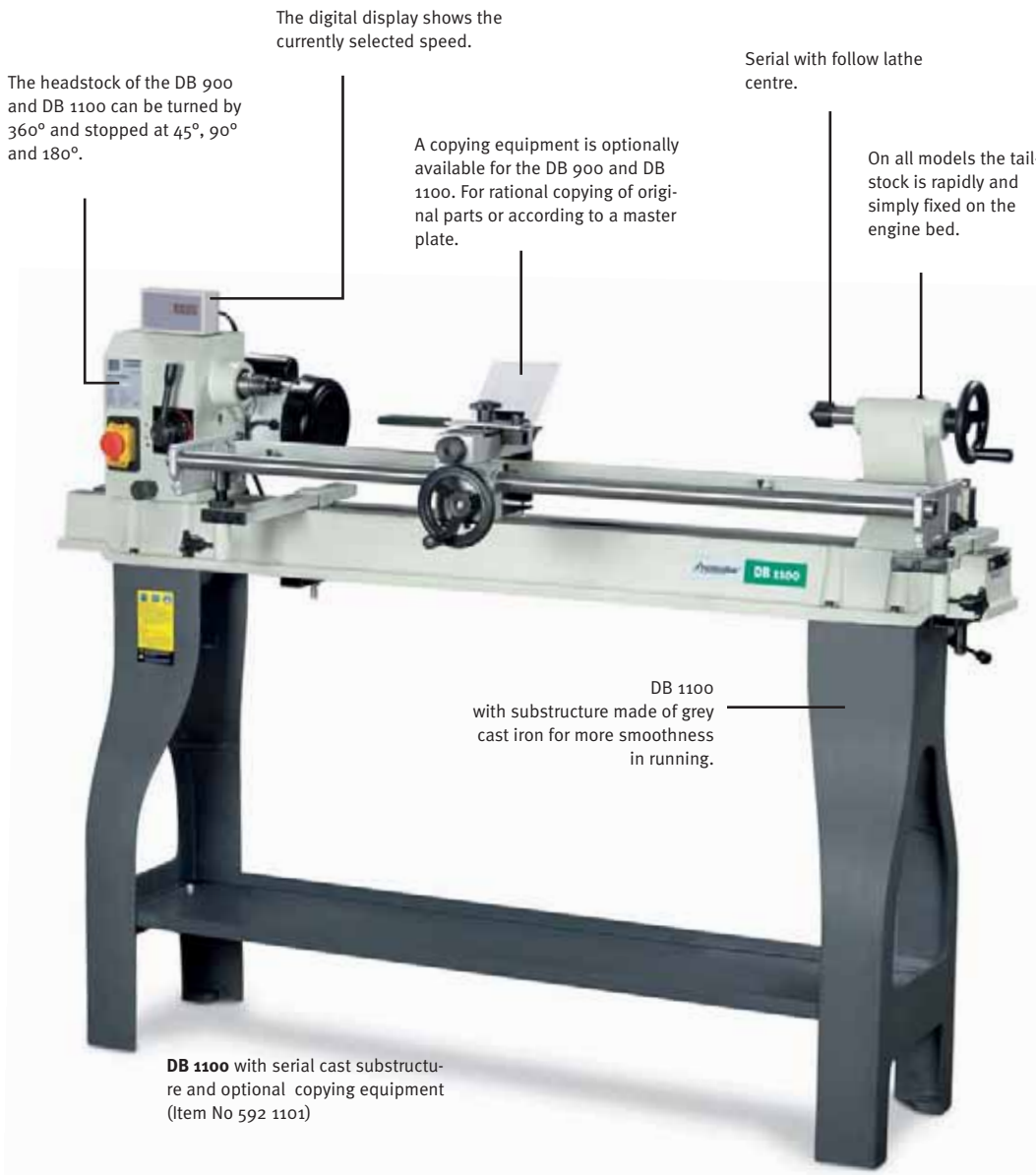

Arguments which will convince you...



Variable speed regulation from 500 to 2.000 1/min. over V-belt and adjustable cone discs.



The required speed can be adjusted rapidly and easily over a lever at the operator's side.



For any turning of workpieces in cross-bar operation which are larger than the gauge for bore holes of the bench you can tilt the spindle stock. The bed elongation together with the repluggable manual tool rests allow maximum flexibility.



The headstock of the DB 1100 can additionally be shifted laterally and it can be stopped at the position of the machine bed.



Turning chisel kit
8-piece



4-jaw chuck kit 1
Ø 100 mm
with screw inserts



4-jaw chucks kit 2
Ø 100 mm with replaceable
jaws and screw insert



4-jaw chuck
Ø 150 mm



steady rest optional
for DB 900
or DB 1100

Accessories	Item No	€ plus VAT
Copying equipment DB 900	592 0901	99,00
Copying equipment DB 1100	592 1101	99,00
8-piece turning chisel kit	593 1011	69,00
1) 4-jaw chuck kit 1 Ø 100 mm*	593 1021	59,00
2) 4-jaw chuck kit 2 Ø 100 mm*	593 1023	89,00
3) 4-jaw chuck Ø 150 mm*	593 1020	25,00
4) Steady rest DB 900	593 1050	29,00
4) Steady rest DB 1100	593 1030	29,00

*for DB 900 and DB 1100

HOLZSTAR suction plants for chips SAA 1001, SAA 2003, SAA 3003 for more performance of the wood working machines and the health of the user.

Arguments which will convince you:

- for milling, planing and drilling chips (no dust)
- ventilator made of metal, of blade shape for enhanced suction performance
- stable construction made of massive steel plate, no fragile plastic material
- low static loading compared to any plastic material constructions
- high suction performance and very quiet
- easy movable with steering rollers
- perfect price-performance ratio



SAA 1001



SAA 2003



SAA 3003

Model	SAA 1001	SAA 2003	SAA 3003
Item No	592 2101	592 2203	592 2303
€ plus VAT	189,00	289,00	399,00

Technical data			
Suction performance	850 m ³ /h	2.553 m ³ /h	3.910 m ³ /h
Nozzle inlet	Ø 100 mm	Ø 125 mm	Ø 150 mm
Nozzle outlet	1 x Ø 100 mm	2 x Ø 100 mm	3 x Ø 100 mm
Power supply	230 V / 1~ 50 Hz	400 V / 3~ 50 Hz	400 V / 3~ 50 Hz
Engine power	750 watts	1.500 watts	2.200 watts
Weight	30 kg	47 kg	59 kg



Polyurethan flexible hose, transparent with spiral, flame resistant, available at lengths of 2,5 / 5,0 / 7,5 and 10,0 m

Dimensions	Item No	€ plus VAT
■ Ø 38 mm	514 2441	10,25 / m
■ Ø 60 mm	514 2445	16,40 / m
■ Ø 80 mm	514 2442	10,25 / m
■ Ø 100 mm	514 2443	14,85 / m
■ Ø 120 mm	514 2444	16,40 / m



Exhaust hose, 2,5 m transparent with spiral

Dimensions	Item No	€ plus VAT
■ Ø 100 mm/2,5 m	514 2401	19,95



Floor cleaning kit 1

- for all suction plants
- including high-quality 2,5 m spiral hose, suction tube, floor nozzle with roles, handle and 2 brackets

Model	BRS 1
Item No	514 8100
€ plus VAT	155,00

Automatic starting for suction plants

- when the wood working machine is being switched on, the suction plant will automatically start with a delay of 2-3 sec., the additional switching on of the suction plant is omitted
- when switching the working machine off, the suction plant will run for about 3-4 sec. longer.
- the remaining dust will be sucked off after switching off the working machine according to the Ordinance on Hazardous Substances
- additional protection of overload of the mains fuse when switching on



Model	ALA 2	ALA 10
Item No	512 1501	512 1502
€ plus VAT	59,00	139,00

Technical data		
Machine power supply-	1x230 V	1x400V/16A 1x230V
Suck off power supply	1x230 V	1x400V/16A 1x230V
Power supply 50-60Hz	230 V/16 A	400 V/16 A
Max. connection power	-	4,0 kW
	with 4 m. line cord	400 V/16 A CE plug

More machines for wood working?

holzkraft[®]
Holzbearbeitungsmaschinen

Wood working machines and accessories for professionals and ambitious craftsmen.



Please select from our range of products of more than 100 different wood working machines in multiple combinations, **panel sizing machines, planing machines, spindle moulding machines, automatic advances, grinding machines, suction plants, joiner's benches, saws for firewood, wood splitters and the corresponding accessories.**

www.holzkraft-maschinen.de

Are you interested in further products?



www.holzkraft-maschinen.de



www.optimum-maschinen.de

www.quantum-maschinen.de



www.aircraft-kompressoren.de



www.schweisskraft.de



www.metallkraft-maschinen.de



www.unicraft.de

- Any existing price lists will become void at the moment of publication of this price catalogue.
- All prices are without engagement, in €, plus the legally applicable VAT.
- All prices are plus dispatch, transport and unloading charges.
- We do not take any liability for misprints, errors or incorrect presentation.
- We reserve the right of technical and optical changes.
- The delivery is performed exclusively according to our terms of delivery and payment.
- The illustrations sometimes show optional accessories
- The items shall be sold by our specialist dealers.
- The merchandise shall remain the property of the company until full payment of the sale price.
- Our ownership reservation shall remain valid upon third-party resale.
- In the commercial sector, the legal terms of warranty shall apply.
- No part of this catalogue may be reproduced and reprinted, in any form whatsoever, without our written authorisation.

Sales Germany:

HOLZSTAR Holzbearbeitungsmaschinen

Dr.-Robert-Pfleger-Str. 26
D-96103 Hallstadt/Bamberg
Phone. (09 51) 96 555 - 0
Fax (09 51) 96 555 - 55
email: info@holzstar-maschinen.de

Sales Austria:

AIRCRAFT Kompressorenbau GmbH
Oberham 31 · A- 4921 Hohenzell
Phone.: ++43 (0) 77 52 - 70 929-0
Fax : ++43 (0) 77 52 - 70 929-99
e-mail: info@aircraft.at
www.aircraft.at

Your specialist supplier:

www.holzstar-maschinen.de