

SL EEK LIFE

PHOTO FEDERICO CEDRONE. STYLING CANDIDA ZANELLI.
PAG 136/141 STYLING MICHELE PASINI.

—

IMMAGINI DI UN INTERNO BORGHESE: UNO SPAZIO CON LA PROPRIA STORIA, VISSUTO CON STILE CONTEMPORANEO. FRA ESSENZIALITÀ DI FORME ED ELEGANZA DEI MATERIALI, UN'INTERPRETAZIONE DEL CLASSICO CHE PREDILIGE RAFFINATI CONTRASTI CROMATICI, NEL VALORE DELLA SEMPLICITÀ.
IMAGES OF A BURGEOIS INTERIOR: A SPACE WITH ITS OWN STORY, A CONTEMPORARY STYLE. ESSENTIALITY OF SHAPES AND ELEGANCE OF MATERIALS, AN REFINED INTERPRETATION OF THE CLASSIC.





IN QUESTA PAGINA E NELLA PRECEDENTE: SINTESI CON CASSETTONI A TERRA WENGÈ', PENSILI CON STRUTTURA WENGÈ' E ANTE VETRO SERIGRAFATO CENERE. POLTRONA ATOLLO RIVESTITA IN TESSUTO SFODERABILE, POUF DUNE RIVESTIMENTO IN TESSUTO SFODERABILE. SOTTO: DIVANO ATOLLO RIVESTITO IN TESSUTO SFODERABILE, LIBRERIA WALL SYSTEM E TAVOLINO YARD WENGÈ'.
 PREVIOUS AND THIS PAGE: SINTESI COMPOSITION WITH CHEST OF DRAWER IN WENGÈ, HANGING CABINETS WITH STRUCTURE IN WENGÈ AND DOORS IN GLASS WITH CENERE SERIGRAPHY. ATOLLO ARMCHAIR COVERED IN REMOVABLE FABRIC, DUNE POUF COVERED IN REMOVABLE FABRIC. BELOW: ATOLLO SOFA COVERED IN REMOVABLE FABRIC. WALL SYSTEM BOOKCASE AND YARD COFFEE TABLE IN WENGÈ.



IN QUESTA PAGINA: LIBRERIA WALL SYSTEM WENGÈ. POUF PLAY IN TESSUTO. LA VERSATILITÀ DEL SISTEMA WALL SYSTEM CONSENTE DI FORMULARE SOLUZIONI EVOLUTE, DOVE LE COMPOSIZIONI CONTRIBUISCONO A DEFINIRE L'ARCHITETTURA DEGLI AMBIENTI.
THIS PAGE: WALL SYSTEM BOOKCASE IN WENGE. POUF PLAY IN FABRIC. THE VERSATILITY OF WALL SYSTEM ALLOWS FANTASTIC SOLUTIONS TO BE CREATED. THESE COMPOSITIONS DEFINE THE ARCHITECTURE OF THE SPACE.





IN QUESTA PAGINA E NELLA PRECEDENTE: CUCINA MATRIX, ANTE LACCATO BIANCO LUCIDO. TOP IN PIETRA BOHUSTAR CON PROFILO SALVAGOCCIA IN DOPPIO SPESSORE: 184 E 52 MM. SCHIENALE IN PIETRA BOHUSTAR. LA VERSATILITÀ PROGETTUALE DEL SISTEMA MATRIX CONSENTE DI REALIZZARE COMPOSIZIONI CON PIANI DI LAVORO DI DIVERSO SPESSORE, PERFETTAMENTE INTEGRATI.
PREVIOUS AND THIS PAGE: MATRIX KITCHEN, WHITE GLOSSY LACQUERED DOORS. COUNTERTOP IN BOHUSTAR STONE WITH NO-DRIP EDGE IN DOUBLE THICKNESS: 7 2/8" AND 2 1/8". BACKSPLASH IN BOHUSTAR STONE. THE VERSATILITY OF THE MATRIX SYSTEM ALLOWS FOR WORKTOPS OF DIFFERENT DEPTHS TO BE PERFECTLY INTEGRATED.



IN QUESTA PAGINA: CUCINA MATRIX, ANTE LACCATO BIANCO LUCIDO. TOP IN PIETRA BOHUSTAR CON PROFILO SALVAGOCCIA IN DOPPIO SPESSORE: 184 E 52 MM. SCHIENALE IN PIETRA BOHUSTAR. CAPPA BOX E PENSILI ATTREZZATI CON CANALINA LUMINOSA.

IN THIS PAGE: MATRIX KITCHEN, WHITE GLOSSY LACQUERED DOORS. COUNTERTOP IN BOHUSTAR STONE WITH NO-DRIP EDGE IN DOUBLE THICKNESS: 7 2/8" AND 2 1/8". BACKSPLASH IN BOHUSTAR STONE. BOX HOOD. UPPER UNITS EQUIPPED WITH LIGHTING CHANNEL.





NELLA PAGINA PRECEDENTE: TAVOLO ASTRID WENGÈ, SEDIE FLIP WENGÈ E TESSUTO. A DESTRA: MADIA TEIA WENGÈ CON QUATTRO ANTE BATTENTI. SOTTO: SEDIA FLIP IN WENGÈ E TESSUTO.
 PREVIOUS PAGE: ASTRID TABLE IN WENGE, FLIP CHAIRS IN WENGE AND FABRIC. ON THE RIGHT: TEIA SIDEBOARD IN WENGE WITH FOUR LEAF DOORS. UNDER: FLIP CHAIR IN WENGE AND FABRIC.



MADIA TEIA WENGÈ CON CASSETTO E VANI GIORNO, POGGIPIEDI FLIP WENGÈ E TESSUTO. LA COLLEZIONE TEIA COMPRENDE CONTENITORI BASSI E ALTI, DISPONIBILI IN UN'AMPIA VARIETÀ DI CONFIGURAZIONI CON ANTE BATTENTI, CASSETTI E VANI A GIORNO. TEIA SIDEBORD IN WENGE WITH DRAWER AND OPEN SPACES, FLIP FOOT-REST WENGE AND FABRIC. TEIA COLLECTION IS COMPOSED OF LOW AND TALL CONTAINERS, AVAILABLE IN MANY DIFFERENT SHAPES.







AND
FTER



IN QUESTA PAGINA E NELLA PRECEDENTE: LETTO ASTRO WENGÈ E TESTATA TESSUTO, BIANCHERIA COORDINATA IN LINO. COMODINI E CASSETTIERA ASTRO WENGÈ, POLTRONCINA E POGGIAPIEDI FLIP WENGÈ E TESSUTO. PREVIOUS AND THIS PAGE: ASTRO BED IN WENGÈ WITH HEADBOARD IN FABRIC, COORDINATED BED LINEN. ASTRO NIGHT TABLES AND CHEST OF DRAWERS IN WENGÈ, FLIP ARMCHAIR AND FOOT-REST IN WENGÈ AND FABRIC.



IN QUESTA PAGINA E NELLA PRECEDENTE: CABINA ARMADIO UBIK MELAMINA WENGÈ, POUF PLAY TESSUTO. IL PROGETTO UBIK OFFRE UN'ECCEZIONALE VARIETÀ DI ATTREZZATURE E ACCESSORI, LIBERAMENTE POSIZIONABILI: UNA CONCEZIONE DELLA CABINA ARMADIO COME STANZA DEDICATA ALL'ORDINE E ADATTABILE AD OGNI ESIGENZA PERSONALE.

PREVIOUS AND THIS PAGE: UBIK WALK-IN CLOSET IN MELAMINE WENGE, POUF PLAY IN FABRIC. THE UBIK PROJECT OFFERS AN EXCEPTIONAL VARIETY OF ELEMENTS WHICH CAN BE FREELY POSITIONED. THE WALK-IN CLOSET BECOMES A ROOM DEDICATED TO ORGANISATION AND ADAPTABLE TO ANY PERSONAL NEED.



RED PASS ION

PHOTO FEDERICO CEDRONE. STYLING PATRIZIA CANTARELLA.
PAG 164/169 STYLING CANDIDA ZANELLI.

UNA CASA CHE RIUNISCE OGGETTI, STORIE, ESPERIENZE, IN PIENO STILE CONTEMPORANEO. COLORI SATURI, FORME ESSENZIALI E PROPOSTE COMPOSITIVE EVOLUTE PER UN PROGETTO D'ARREDO COMPLETO, BASATO SU UN'IDEA DI ABITARE SEMPRE PIÙ PERSONALE.
HOME AS A COLLECTION OF OBJECTS, STORIES, EXPERIENCES. A TRUE CONTEMPORARY STYLE, RICH COLORS, ESSENTIAL SHAPES AND DIFFERENT PROPOSALS CREATE A TOTAL LIVING STYLE WITH PERSONALITY AND INDIVIDUALITY.







IN QUESTA PAGINA E NELLA PRECEDENTE: COMPOSIZIONE WALL SYSTEM WENGÈ, ANTE SLIM LACCATO LUCIDO CORDA, VANO CENTRALE DOTATO DI ILLUMINAZIONE, SPORTELLO PASSACAVI INCASSATO E ATTREZZATO CON PORTA CD/DVD IN ALLUMINIO. TAVOLINI ARTONE WENGÈ. A FIANCO E NELLA PAGINA SEGUENTE: DIVANO SHANGAI RIVESTITO IN TESSUTO SFODERABILE. TAVOLINO YARD WENGÈ.
PREVIOUS AND THIS PAGE: WALL SYSTEM BOOKCASE IN WENGE, SLIM DOORS CORDA GLOSSY LACQUERED, CENTRAL SPACE WITH LIGHT, WIRES BUILT-IN DOOR EQUIPPED WITH CD/DVD SHELVES IN ALUMINIUM. ARTONE COFFEE TABLES IN WENGE. ON THE SIDE AND IN THE FOLLOWING PAGE: SHANGAI SOFA COVERED IN REMOVABLE FABRIC. YARD COFFEE TABLE IN WENGE.

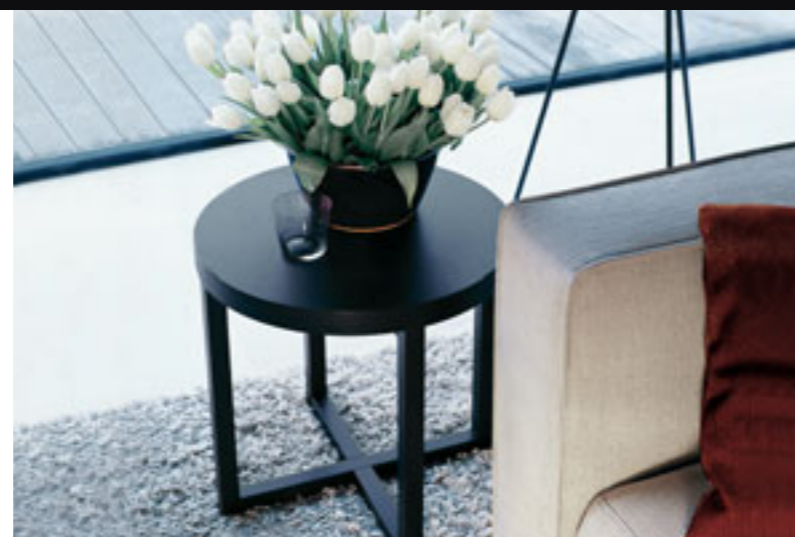



CUCINA MATRIX CON ISOLA CON ANTE E VANI A GIORNO WENGÈ. TOP IN ACCIAIO, DOPPIO SPESSORE 80 MM E 20 MM. SGABELLI CON SEDUTA WENGÈ E STRUTTURA ACCIAIO. BOISERIE WENGÈ, FRIGORIFERI E WINE COOLERS IN ACCIAIO. ANTE SCORREVOLI CLOSE, TELAIO ALLUMINIO ANODIZZATO NERO E CRISTALLO TRASPARENTE. MATRIX KITCHEN ISLAND WITH DOORS AND LIVING SPACES WENGE. COUNTERTOP IN STAINLESS STEEL OF DOUBLE THICKNESS 3 1/8" AND 6/8". STOOLS WITH SEAT IN WENGE AND STRUCTURE IN STEEL. BACK PANELS IN WENGE, REFRIGERATORS AND WINE COOLERS IN STAINLESS STEEL. CLOSE SLIDING DOORS BY POLIFORM, FRAME IN BLACK ALUMINIUM AND TRANSPARENT GLASS.







IN QUESTA PAGINA E NELLA PRECEDENTE: CUCINA MATRIX CON ISOLA CON ANTE E VANI A GIORNO WENGÈ. TOP IN ACCIAIO, DOPPIO SPESSORE 80 MM E 20 MM. CAPP A PIATTA AD ISOLA. COLONNE CON ANTE LACCATO LUCIDO CORDA. SGABELLI CON SEDUTA WENGÈ E STRUTTURA ACCIAIO. BOISERIE WENGÈ, FRIGORIFERI E WINE COOLERS IN ACCIAIO. ANTE SCORREVOLI CLOSE, TELAIO ALLUMINIO ANODIZZATO NERO E CRISTALLO TRASPARENTE. PREVIOUS AND THIS PAGE: MATRIX KITCHEN ISLAND WITH DOORS AND LIVING SPACES WENGÈ. COUNTERTOP IN STAINLESS STEEL OF DOUBLE THICKNESS 3 1/8" AND 6/8". PIATTA HOOD ABOVE ISLAND. TALL UNITS WITH DOORS IN CORDA GLOSSY LACQUER. STOOLS WITH SEAT IN WENGÈ AND STRUCTURE IN STEEL. BACK PANELS IN WENGÈ, REFRIGERATORS AND WINE COOLERS IN STAINLESS STEEL. CLOSE SLIDING DOORS, FRAME IN BLACK ALUMINIUM AND TRANSPARENT GLASS.

MADIA SLIM LACCATO LUCIDO CORDA. TAVOLO ARTONE DUE WENGÈ, SEDIE VALENTINA WENGÈ E TESSUTO. LA COLLEZIONE SLIM COMPRENDE MADIE ALTE E BASSE CHE OFFRONO DIVERSE POSSIBILITÀ DI CONFIGURAZIONE. LA MASSIMA ESSENZIALITÀ È LA CARATTERISTICA ESTETICA DEI CONTENITORI SLIM, SOTTOLINEATA DALL'ASSENZA DELLE MANIGLIE.

SLIM SIDEBOARD CORDA GLOSSY LACQUERED. ARTONE DUE TABLE IN WENGE, VALENTINA CHAIR IN WENGE AND FABRIC. THE SLIM COLLECTION OFFERS TALL AND LOW SIDEBOARDS WHICH OFFER DIFFERENT LOOKS. THE KEY AESTHETICAL CHARACTERISTIC OF SLIM CONTAINERS IS A SEAMLESS APPEARANCE UNDERLINED BY THE LACK OF HANDLES.





IN QUESTA PAGINA: TAVOLO ARTONE DUE WENGÉ, SEDIE VALENTINA WENGÉ
E TESSUTO.
THIS PAGE: ARTONE DUE TABLE IN WENGE, VALENTINA CHAIR IN WENGE
AND FABRIC.



IN QUESTA PAGINA: CASSETTIERA TEO WENGÈ. NELLA PAGINA SUCCESSIVA: LETTO TEO RIVESTITO COMPLETAMENTE IN PELLE, BIANCHERIA COORDINATA IN LINO. COMODINI TEO WENGÈ. IL LETTO TEO È DISPONIBILE ANCHE IN LEGNO, LACCATO OPPURE RIVESTITO IN TESSUTO O CUIOIO.
THIS PAGE: TEO CHEST OF DRAWERS IN WENGE. FOLLOWING PAGE: TEO BED COMPLETELY COVERED IN LEATHER, COORDINATED BED LINEN. TEO NIGHT TABLES IN WENGE. TEO BED IS ALSO AVAILABLE IN WOOD, LACQUERED COLOURS OR UPHOLSTERED IN FABRIC OR HIDE.





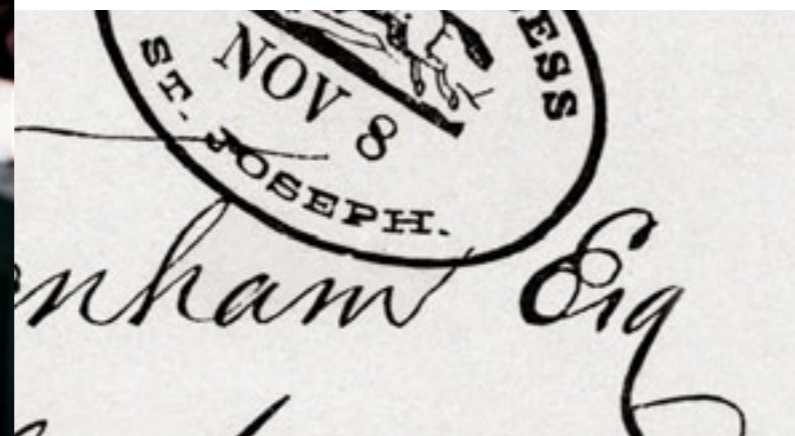

IN QUESTA PAGINA: CABINA ARMADIO UBIK IN MELAMINA WENGÈ, POLTRONCINA FLIP WENGÈ E TESSUTO. A DESTRA: LETTO TEO RIVESTITO IN PELLE. NELLA PAGINA SEGUENTE: ARMADIO SENZAFINE NEW ENTRY APERTURA BATTENTE ANTE LACCATO LUCIDO CORDA. POLTRONCINA E POGGIAPIEDI FLIP WENGÈ E TESSUTO.
THIS PAGE: UBIK WALK-IN CLOSET IN MELAMINE WENGÈ, FLIP ARMCHAIR IN WENGÈ AND FABRIC. ON THE RIGHT: TEO BED COVERED IN LEATHER. FOLLOWING PAGE: SENZAFINE NEW ENTRY WARDROBE CORDA GLOSSY LACQUERED LEAF DOORS. FLIP ARMCHAIR AND FOOT-REST IN WENGÈ AND FABRIC.



WALL SYSTEM PAG. 7-8-9-10-102-104-134-159-161 DESIGN CR&S POLIFORM.

SISTEMA componibile a spalle portanti e ripiani disponibile in 7 altezze, 5 larghezze e 2 profondità. L'AMPIA modularità consente al sistema di adattarsi ad ogni situazione architettonica, anche la più complessa. Il sistema è caratterizzato dai fianchi e dai ripiani di spessore mm 35, che ne sottolineano la solidità formale e il rigore geometrico. Ante in legno o vetro, con apertura battente, scorrevole o a ribalta; cassetti in legno, attrezzature per vani a giorno.

SOLUZIONI SPECIALI TAGLI A MISURA IN LARGHEZZA, ALTEZZA E PROFONDITÀ; LE FASCE DI TAMPONAMENTO ORIZZONTALI E VERTICALI; I CAMBI DI PROFONDITÀ; LE SOLUZIONI ANGOLARI: POSSIBILITÀ CHE CONFERMANO L'ECCEZIONALE FLESSIBILITÀ DEL SISTEMA WALL SYSTEM, IN GRADO DI ADATTARSI AD OGNI SPAZIO.

WALL SYSTEM AVAILABLE IN 7 DIFFERENT HEIGHTS, 5 WIDTHS AND 2 DEPTHS. THIS FREESTANDING MODULAR SYSTEM IS ADAPTABLE TO EVEN THE MOST COMPLEX ARCHITECTURAL CONFIGURATION. WALL SYSTEM IS CHARACTERIZED BY VERTICAL PANELS AND SHELVES OF 1 1/2" WHICH UNDERLINE THE SOLIDITY OF SHAPES AND THE GEOMETRY. WOODEN OR GLASS DOORS, LEAF, SLIDING OR FLAP OPENING; WOODEN DRAWERS, EQUIPMENTS FOR OPEN SPACES.

SPECIAL SOLUTIONS THE AVAILABILITY OF CUSTOM CUTS IN HEIGHT, DEPTH AND WIDTH PLUS THE ABILITY TO COMBINE DIFFERENT DEPTHS WITH STANDARD HORIZONTAL, VERTICAL AND ANGULAR FILLERS CONFIRM THE ADAPTABILITY OF THE WALL SYSTEM.

	320 12 5/8"	471 18 1/2"	640 25 1/4"	978 38 1/2"	1316 51 3/4"	
2673						105 1/4"
2299						90 1/2"
1925						75 3/4"
1551						61 1/8"
1177						46 3/8"
803						31 5/8"
429						16 7/8"
320 416						12 1/2" 16 3/8"

PER OTTENERE LA LARGHEZZA TOTALE, ALLA SOMMA DELLA LARGHEZZA DEI RIPIANI AGGIUNGERE MM 35 PER OGNI SPALLA PORTANTE.

TO OBTAIN THE TOTAL WIDTH, ADD TO THE TOTAL SHELVES 35 MM 1 1/2" FOR EACH SIDE PANEL.

FINITURE STRUTTURA
WENGÉ, NOCE C., 25 VARIANTI DI COLORE PER IL LACCATO OPACO E LUCIDO.

FINITURE FACCIATE E ELEMENTI SPECIALI
WENGÉ, NOCE C., 20 VETRI, 25 VARIANTI DI COLORE PER IL LACCATO OPACO E LUCIDO.

FINISHING STRUCTURE
WENGE, WALNUT C., 25 COLOURS FOR MAT LACQUERING AND GLOSSY LACQUERING.

FINISHING DOORS AND SPECIAL ELEMENTS
WENGE, WALNUT C., 20 GLASSES, 25 COLOURS FOR MAT LACQUERING AND GLOSSY LACQUERING.



WALL SYSTEM CON STRUTTURA, PIANO SCRITTOIO, CASSETTI SLIM E ANTE SLIM A RIBALTA LACCATO OPACO BIANCO. POUF PLAY RIVESTITI IN TESSUTO SFODERABILE. POLTRONA BALI RIVESTITA IN TESSUTO. TAVOLINO VULCANO LACCATO OPACO PRATO.

WALL SYSTEM WITH STRUCTURE, WRITING DESK, SLIM DRAWERS AND SLIM FLAP DOORS WHITE MAT LACQUERED. POUF PLAY COVERED IN REMOVABLE FABRIC. BALI ARMCHAIR COVERED IN FABRIC. VULCANO COFFEE TABLE MAT LACQUERED.



WALL SYSTEM LACCATO BIANCO. INSERTI ATTREZZATI LACCATO OPACO GRAFITE. TAVOLO TREVÌ LACCATO OPACO OCEANO. SEDIE STRIP VERSIONE GIREVOLE SU RUOTE, SCOCCA IN PLASTICA E CUSCINO IN TESSUTO. POUF PLAY RIVESTITO IN TESSUTO SFODERABILE.

WALL SYSTEM WHITE MAT LACQUERED. EQUIPPED INSERTS GRAFITE MAT LACQUERED. TREVÌ TABLE OCEANO MAT LACQUERED. STRIP CHAIRS WITH WHEELS, PLASTIC REVOLVING BASE AND CUSHION IN FABRIC. POUF PLAY COVERED IN REMOVABLE FABRIC.



WALL SYSTEM STRUTTURA, SCHIENALI E CASSETTO BASIC WENGÉ. ANTE SLIM BATTENTI LACCATO LUCIDO BIANCO. ANTA BOX SCORREVOLE IN VETRO EXTRACHIARO LUCIDO BIANCO. POLTRONA ATOLLO E POUF PLAY RIVESTITI IN TESSUTO SFODERABILE. TAVOLINO TRIDENTE LACCATO NERO OPACO.

WALL SYSTEM STRUCTURE, BACK PANELS AND BASIC DRAWER IN WENGE. SLIM LEAF DOORS WHITE GLOSSY LACQUERED. BOX SLIDING DOOR IN EXTRALIGHT WHITE GLOSSY GLASS. ATOLLO ARMCHAIR AND PLAY POUF COVERED IN REMOVABLE FABRIC. TRIDENTE COFFEE TABLE BLACK MAT LACQUERED.



WALL SYSTEM STRUTTURA, SCHIENALE PORTANTE E CONTENITORI A TERRA WENGÉ. ANTE SLIM BATTENTI LACCATO LUCIDO VISIONE. POLTRONCINE CAMILLA STRUTTURA WENGÉ, RIVESTIMENTO IN PELLE. POUF PLAY RIVESTITO IN TESSUTO SFODERABILE.

WALL SYSTEM WITH STRUCTURE, BEARING BACK PANEL AND FLOOR CONTAINERS IN WENGE. SLIM LEAF DOORS VISIONE GLOSSY LACQUERED. CAMILLA ARMCHAIRS WITH STRUCTURE IN WENGE AND COVERING IN LEATHER. POUF PLAY COVERED IN REMOVABLE FABRIC.



WALL SYSTEM CON STRUTTURA, SCHIENALE PORTANTE E CONTENITORI A TERRA FINITURA WENGÉ, ANTA SCORREVOLE FRAME VETRO FUMÉ E TELAIO WENGÉ. POLTRONA SNAKE RIVESTITA IN PELLE INVECCHIATA.

WALL SYSTEM WITH STRUCTURE, BEARING BACK PANEL AND FLOOR CONTAINER IN WENGE. FRAME SLIDING DOOR IN FUMÉ GLASS AND FRAME IN WENGE. SNAKE ARMCHAIR COVERED IN AGED LEATHER.

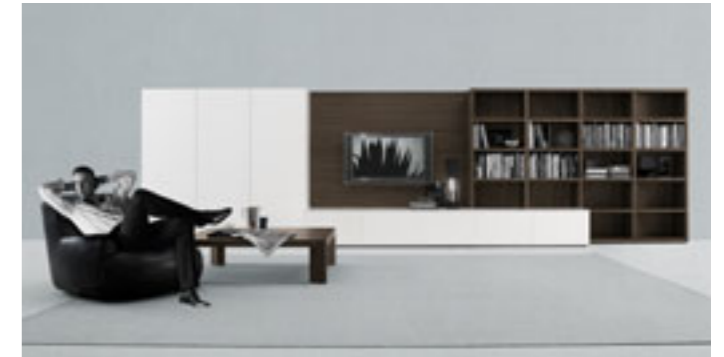

WALL SYSTEM CON VANI A GIORNO, SCHIENALI E BOISERIE NOCE C. ELEMENTI SPORGENTI A TERRA CON CASSETTI LACCATO LUCIDO BIANCO. CONTENITORI VERTICALI CON ANTE SLIM LACCATO LUCIDO BIANCO. POLTRONA BUG RIVESTITA IN PELLE. TAVOLINO ZEUS NOCE C.

WALL SYSTEM WITH OPEN SPACES, BACK PANELS AND BOISERIE IN WALNUT C. FLOOR PROJECTING ELEMENTS WITH DRAWERS WHITE GLOSSY LACQUERED. BUG ARMCHAIR COVERED IN LEATHER. ZEUS COFFEE TABLE IN WALNUT C.



WALL SYSTEM CON STRUTTURA LACCATO OPACO BIANCO. ANTA BOX SCORREVOLE VETRO BIANCO LUCIDO. INSERTI ATTREZZATI NOCE C. POLTRONCINA E POGGIAPIEDI FLIP NOCE C. E TESSUTO.

WALL SYSTEM WITH STRUCTURE WHITE MAT LACQUERED. BOX SLIDING DOOR WHITE GLOSSY GLASS. EQUIPPED INSERTS IN WALNUT C. FLIP ARMCHAIR AND FOOT-REST IN WALNUT C. AND FABRIC.



WALL SYSTEM CON STRUTTURA LACCATO LUCIDO VISIONE. ANTE SLIM BATTENTI LACCATO LUCIDO VISIONE. INSERTI ATTREZZATI WENGÉ. POLTRONA BUG RIVESTITA IN TESSUTO SFODERABILE.

WALL SYSTEM WITH STRUCTURE VISIONE GLOSSY LACQUERED. SLIM LEAF DOORS VISIONE GLOSSY LACQUERED. EQUIPPED INSERTS IN WENGE. BUG ARMCHAIR COVERED IN REMOVABLE FABRIC.

SINTESI PAG. 40-42-71-72-108-110-130-132 DESIGN CARLO COLOMBO.

SINTESI È UN PROGRAMMA COMPONIBILE BASATO SUL LIBERO ACCOSTAMENTO DI ELEMENTI A TERRA E A PARETE: PANCHE, CONTENITORI CON ANTE O CASSETTI, PENSILI, MENSOLE E BOISERIE, A CUI SI INTEGRANO CONTENITORI "FREE-STANDING".

FINITURE 2 ESSENZE, NOCE C. E WENGÈ. 25 VARIANTI DI COLORE PER IL LACCATO OPACO E LUCIDO, 8 COLORI VETRO LUCIDO, 8 COLORI VETRO SATINATO, 2 COLORI VETRO SERIGRAFATO, VETRO RIFLETTENTE BLU.

SINTESI A MODULAR SYSTEM DESIGNED FOR A CONTEMPORARY LIVING ROOM ENVIRONMENT. IT ALLOWS FOR UNLIMITED AND ORIGINAL COMPOSITIONS BASED ON FREESTANDING AND WALL MOUNTED CABINETS, LOW BENCHES, SHELVES, WALL PANELS, AS WELL AS A SIDEBBOARD WITH DOOR AND/OR DRAWERS.

FINISHING 2 WOODS, WALNUT C. AND WENGÈ. 25 COLOURS FOR MAT LACQUERING AND GLOSSY LACQUERING, 8 COLOURS GLOSSY GLASS, 8 COLOURS MAT GLASS, 2 COLOURS SERIGRAPHED GLASS, REFLECTING GLASS BLU.

LARGHEZZE / WIDTHS

600 MM
23 5/8"

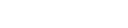
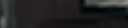
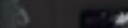
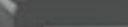
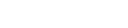
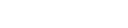

900 MM
35 7/16"

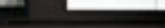
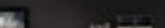
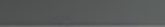

1200 MM
47 1/4"

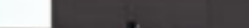

1800 MM
70 7/8"

**PANCA**

PROFONDITÀ MM 602
ALTEZZA MM 123

CASSETTONE A TERRA

ANTA RIBALTA O CASSETTO
PROFONDITÀ MM 602
ALTEZZA MM 335

MADIA

ANTE BATTENTI E CASSETTONE
CON CASSETTO INTERNO
PROFONDITÀ MM 602
ALTEZZA MM 485

MENSOLONE SOSPESO

CON SCHIENALE A TERRA
PROFONDITÀ MM 642
ALTEZZA MM 635

MENSOLONE SCRITTOIO

CON SCHIENALE A TERRA
PROFONDITÀ MM 642
ALTEZZA MM 735

CASSETTONE SOSPESO

CON SCHIENALE A TERRA
PROFONDITÀ MM 642
ALTEZZA MM 635

PANNELLATURA CON MENSOLE

MENSOLE IN STRATIFICATO
O ALLUMINIO
PROFONDITÀ MM 279
ALTEZZA MM 600 1/2 MENSOLE
ALTEZZA MM 900 2/3 MENSOLE
ALTEZZA MM 1200 3/4 MENSOLE

BENCH

DEPTH 23 11/16"
HEIGHT 4 13/16"

CHEST OF DRAWERS

FLIP OPENING DOOR OR DRAWER
DEPTH 23 11/16"
HEIGHT 13 3/16"

SIDEBBOARD

LEAF DOORS AND DRAWER COM-
PLETE OF SMALL INNER DRAWER
DEPTH 23 11/16"
HEIGHT 19 1/8"

HANGING BIG SHELF

WITH BACK PANEL TO THE FLOOR
DEPTH 25 1/4"
HEIGHT 25"

HANGING SHELF WRITING DESK

WITH BACK PANEL TO THE FLOOR
DEPTH 25 1/4"
HEIGHT 28 15/16"

HANGING CHEST OF DRAWERS

WITH BACK PANEL TO THE FLOOR
DEPTH 25 1/4"
HEIGHT 25"

WALL PANEL WITH SHELVES

STRATIFIED OR ALUMINIUM
SHELVES
DEPTH 11"
HEIGHT 23 5/8" 1/2 SHELVES
HEIGHT 35 7/16" 2/3 SHELVES
HEIGHT 47 1/4" 3/4 SHELVES

LARGHEZZE / WIDTHS

600 MM
23 5/8"

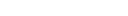
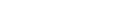
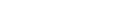
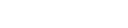

900 MM
35 7/16"



1200 MM
47 1/4"

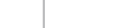

1800 MM
70 7/8"



POLIFORM SPA
 VIA DEGLI ARTIGIANI, 51
 LURAGO D'ERBA (CO) ITALY
 TEL +39/031695401
 FAX +39/031695444
 INFO.VARENNA@POLIFORM.IT
 WWW.POLIFORM.IT

Varenna
 Poliform

HIGH QUALITY SYSTEM VARENNA È LA DIVISIONE POLIFORM DEDICATA ALLA PRODUZIONE DELLE CUCINE. UNA REALTÀ AZIENDALE DOTATA DI UN GRANDE PATRIMONIO DI ESPERIENZA E DI UN KNOW-HOW SPECIFICO, CHE HA FATTO DELLA COSTANTE RICERCA DELLA QUALITÀ IL PROPRIO METODO DI LAVORO. REALIZZARE CUCINE SIGNIFICA LAVORARE CON MOLTI MATERIALI, DIVERSISSIMI FRA DI LORO: DAL LEGNO ALL'ACCIAIO, PASSANDO PER IL MARMO, L'ALLUMINIO E UNA SERIE DI MODERNI COMPOSTI SINTETICI. SELEZIONANDO I MIGLIORI FORNITORI E UTILIZZANDO UNICAMENTE COMPONENTI SOTTOPOSTI AI PIÙ SEVERI COLLAUDI, VARENNA GARANTISCE LA MASSIMA AFFIDABILITÀ, SICUREZZA E DURATA NEL TEMPO DELLE PROPRIE CUCINE.

HIGH QUALITY SYSTEM VARENNA IS THE BRAND OF POLIFORM DEDICATED TO THE KITCHENS. THANKS TO ITS LARGE EXPERIENCE AND SPECIFIC KNOW-HOW VARENNA HAS MADE OF THE CONSTANT SEARCH OF THE QUALITY THE METHOD OF ITS JOB. TO PRODUCE A KITCHEN IT IS NECESSARY TO WORK WITH MANY DIFFERENT MATERIALS: FROM WOOD TO STEEL, FROM MARBLE TO ALUMINIUM, INCLUDING SOME MODERN SYNTHETIC COMPOUNDS. SELECTING THE BEST SUPPLIERS AND USING ONLY MATERIALS SUBMITTED TO THE MOST STRICTLY TESTS VARENNA GUARANTEES THE RELIABILITY, SAFETY AND LASTINGNESS OF ITS KITCHENS.



LA QUALITÀ DELLA PRODUZIONE

OGNI CUCINA VARENNA È UNICA, PERCHÉ VIENE PRODOTTA SU ORDINAZIONE PER OGNI SINGOLO CLIENTE. IN QUESTO MODO È POSSIBILE ASSICURARE LA PERFETTA OMOGENEITÀ DI VENATURE E COLORE IN OGNI MATERIALE, DAI LEGNI ALLE PIETRE. INOLTRE QUESTO METODO CONSENTE UN'ECCELLENTI LIBERTÀ DI PERSONALIZZARE OGNI COMPOSIZIONE. SCEGLIENDO UNA PROPOSTA VARENNA AVRETE LA SICUREZZA DI ACQUISTARE UNA CUCINA PRODOTTA APPOSITAMENTE PER VOI, CON LE DIMENSIONI, LE FINITURE, LE SOLUZIONI FUNZIONALI CHE VOI AVETE SCELTO.

THE QUALITY OF THE PRODUCTION EVERY VARENNA KITCHEN IS UNIQUE, TAILOR MADE FOR EACH SINGLE CUSTOMER. IN THIS WAY WE COULD GUARANTEE THE PERFECT HOMOGENEITY OF VEINS AND COLOURS IN EVERY MATERIALS, FROM WOOD TO STEEL. AT THE SAME TIME THIS KIND OF WORKING ALLOWS AN EXCEPTIONAL POSSIBILITY OF PERSONALIZATION FOR EACH SINGLE COMPOSITION. CHOOSE A VARENNA KITCHEN MEANS BUY A KITCHEN MADE FOR YOU, WITH DIMENSIONS, FINISHINGS AND FUNCTIONAL SOLUTIONS SELECTED BY YOU.

L'AFFIDABILITÀ NEL TEMPO

LE GUIDE DEI CASSETTI SONO COLLAUDATE PER UNA PORTATA DI 30 KG LA COPPIA (CIRCA 700 POSATE) E PER 100.000 CICLI DI APERTURA E CHIUSURA. LE CERNIERE DELLE ANTE SONO TESTATE PER 200.000 APERTURE: COME APRIRE UNA CREDENZA PER OTTO VOLTE AL GIORNO, TUTTI I GIORNI, PER 68 ANNI. LE GUIDE DEGLI ESTRATTORI HANNO UNA PORTATA DI 50 KG LA COPPIA, EQUIVALENTE A CIRCA 8 CONFEZIONI DA 6 BOTTIGLIE D'ACQUA DA 1,5 LITRI.

A TIMELESS FIDELITY THE DRAWERS ARE TESTED FOR A CAPACITY OF 30 KG (APPROXIMATELY 700 CUTLERY PIECES) AND FOR 100.000 CYCLES OF OPENING AND CLOSING. THE HINGES OF THE DOORS ARE TESTED FOR 200 000 OPENINGS: TO PUT IN CONTEXT IT IS THE EQUIVALENT OF OPENING ONE SIDEBOARD FOR EIGHT TIMES PER DAY, EVERY DAY, FOR 68 YEARS. THE DEEP PAN DRAWERS HAVE A CAPACITY OF 50 KG, WHICH IS EQUIVALENT TO 8 BOXES OF 6 WATER BOTTLES OF 1,5 LITERS.

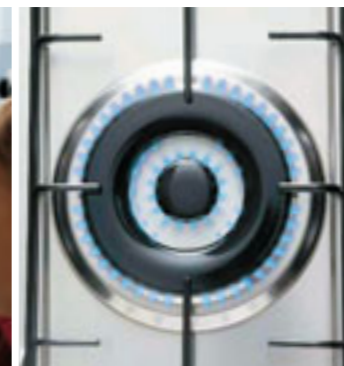
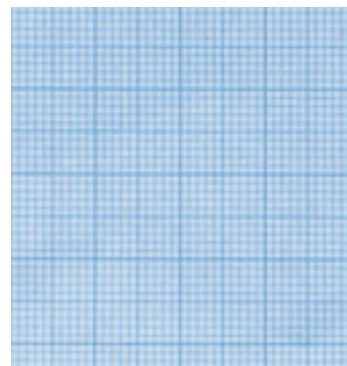

LA QUALITÀ DEL PROGETTO

LA COLLEZIONE VARENNA, FRUTTO DELLA COLLABORAZIONE CON ALCUNI DEI PIÙ PRESTIGIOSI DESIGNER ITALIANI E INTERNAZIONALI, È UN SISTEMA COMPONENTIBILE: OGNI CUCINA PUÒ ESSERE REALIZZATA IN TUTTE LE VARIANTI DIMENSIONALI. LE BASI PREVEDONO BEN 8 LARGHEZZE, DA MM 150 A 1200. CON UNA SIMILE VERSATILITÀ, OGNI MODELLO PUÒ ADATTARSI AD OGNI ESIGENZA DI SPAZIO. INOLTRE, TUTTE LE PROPOSTE VARENNA POSSONO ESSERE REALIZZATE "SU MISURA", OVVERO ESATTAMENTE SECONDO LE MISURE DELL'AMBIENTE A CUI LA CUCINA È DESTINATA.

THE QUALITY OF THE PLAN EVERY VARENNA KITCHEN REFLECTS CREATIVITY AND FUNCTIONALITY. IT IS THE PRODUCT OF THE COLLABORATION OF PRESTIGIOUS ITALIAN AND INTERNATIONAL DESIGNERS. THE COLLECTION IS CHARACTERIZED BY A COMPONENT SYSTEM: ALL KITCHENS ARE BESPOKE, THE BASES COME IN 8 DIFFERENT WIDTHS, FROM 6" TO 47 1/4". WITH A SIMILAR VERSATILITY, UNITS WILL FIT TO ALL REQUIREMENTS.

LA QUALITÀ DEL MADE IN ITALY

OGNI CUCINA VARENNA VIENE REALIZZATA IN ITALIA, RISULTATO DI UN NETWORK CHE COMPRENDE I MIGLIORI FORNITORI EUROPEI ED INTERNAZIONALI. MA A RENDERE VARENNA UN ESEMPIO DI "MADE IN ITALY" AL 100% SONO I SUOI VALORI: LA CREATIVITÀ SENZA LIMITI; LA TRADIZIONE NEL MONDO DEL MOBILE CHE RISALE AL 1942, E CHE SI TRADUCE IN UN'ESPERIENZA E UN KNOW-HOW SPECIFICI; LA QUALITÀ CHE È NATURALE PER UN'AZIENDA CHE SI CONFRONTA CONTINUAMENTE CON IL PROPRIO PUBBLICO E LE SUE ESIGENZE.

THE QUALITY OF THE MADE IN ITALY VARENNA KITCHENS ARE PRODUCED IN ITALY, WITH THE COLLABORATION OF THE BEST EUROPEAN AND INTERNATIONAL MATERIALS. THE LIMITLESS CREATIVITY, THE EXPERIENCE IN THE FURNITURE SECTOR SINCE 1942 AND THE SPECIFIC KNOW-HOW, REFLECT AT 100% THE "MADE IN ITALY" PHILOSOPHY.

GLI ELETTRODOMESTICI

DAI FORNI AI PIANI COTTURA, DALLE LAVASTOVIGLIE AI FRIGOCONGELATORI: VARENNA NON SI LIMITA A PROPORRE LE MIGLIORI MARCHE, MA PER OGNUNA OFFRE UN'AMPIA SCELTA DI MODELLI, DALLE SOLUZIONI BASIC A QUELLE PIÙ EVOLUTE. CON PARTICOLARE ATTENZIONE AGLI ELETTRODOMESTICI PIÙ SICURI, ANCHE PER I BAMBINI, E A BASSO CONSUMO ENERGETICO (CLASSE A). LA VERSATILITÀ DEL SISTEMA È TALE DA CONSENTIRE L'INSERIMENTO IN OGNI CUCINA DELLA QUASI TOTALITÀ DELLE PROPOSTE PRESENTI SUL MERCATO.

THE APPLIANCES VARENNA OFFERS A WIDE RANGE OF APPLIANCES OF THE BEST BRANDS. HOBBS, OVENS, DISHWASHERS AND FRIDGES ARE AVAILABLE IN DIFFERENT MODELS WHICH MEET BASIC AND SOPHISTICATED REQUIREMENTS. VARENNA PAYS PARTICULAR ATTENTION FOR A SAFE ENVIRONMENT FOR CHILDREN AND PROMOTES LOW ENERGY CONSUMPTION (CLASS A). THE VERSATILITY OF THE SYSTEM ALLOWS YOU TO USE NEARLY ANY APPLIANCE IN THE MARKET.

LA QUALITÀ ACCESSIBILE

OGNI CUCINA VARENNA È UN PRODOTTO DI ALTA QUALITÀ ESTETICA E FUNZIONALE, CREATO PER GARANTIRE LA MASSIMA AFFIDABILITÀ NEL TEMPO. QUESTE CARATTERISTICHE TROVANO RISCOSAMENTO IN UN VALORE ECONOMICO ASSOLUTAMENTE EQUILIBRATO, ACCESSIBILE A TUTTI. VARENNA OFFRE INFATTI LA POSSIBILITÀ DI ACQUISTARE IMMEDIATAMENTE LE PROPRIE PROPOSTE ATTRAVERSO FORME DI FINANZIAMENTO PERSONALIZZATO. POTRETE SCOPRIRE TUTTE LE SOLUZIONI PRESSO I PUNTI VENDITA VARENNA.

THE ACCESSIBLE QUALITY EVERY VARENNA KITCHEN IS PRODUCED WITH HIGH AESTHETIC AND FUNCTIONAL STANDARDS TO GUARANTEE A LONG-LASTING FIDELITY AND "OFFER A VALUE FOR MONEY" KITCHEN.



ALEA PAG. 16/21
DESIGN PAOLO PIVA
E CR&S VARENNA.

VOLUMI GEOMETRICI, MASSIMA SEMPLICITÀ, SUPERFICI CHE VALORIZZANO MATERIALI E FINITURE. UN PROGETTO CHE RIDUCE OGNI ELEMENTO ALLA SUA FORMA ESSENZIALE.

GEOMETRIC UNITS, MAXIMUM SIMPLICITY, HIGHLIGHTING THE VALUE OF MATERIALS AND FINISHES. A PROJECT THAT CONFINES EVERY ELEMENT TO ITS FORM AND FUNCTION.



MATRIX PAG. 47/50-80/84-136/140-164/169
DESIGN PAOLO PIVA
E CR&S VARENNA.

PROGETTO PRIMARIO. VOLUMI DI FORTE SPESSORE, FORME PURE PER UNA CUCINA DALLO STILE RIGOROSO. MASSIMA VERSATILITÀ COMPOSITIVA PER CREARE SOLUZIONI ESCLUSIVE.

PROJECT OBJECTIVE: BOLD LINES WITHIN A PURE FORM FOR A RIGOROUS STYLE OF KITCHEN WITH MAXIMUM VERSATILITY CREATING A UNIQUE AND INDIVIDUAL SOLUTION.



MINIMAL
DESIGN CR&S VARENNA.

RIGOROSA NELL'ESTETICA, RICCHISSIMA NELLA VARIETÀ DI MATERIALI E FINITURE. SOLUZIONI COMPOSITIVE EVOLUTE, CARATTERIZZATE DALLA MANIGLIA INTEGRATA NELL'ANTA.

RIGOROUS ESTHETICS, ONE MATERIAL, ONE FINISH WITH AN INTEGRATED HANDLE IN THE DOOR TO CREATE THE ULTIMATE PURE SOLUTION.



YOUNG PAG. 112-114-116
DESIGN CARLO COLOMBO
E CR&S VARENNA.

SEMPLICE, ESSENZIALE, CONTEMPORANEA. YOUNG È LA PROPOSTA BASIC DELLA COLLEZIONE VARENNA. UNA CUCINA IMMEDIATA, APERTA AD OGNI INTERPRETAZIONE.

SIMPLE, ESSENTIAL, CONTEMPORARY. YOUNG IS THE PURE AND BASIC VARENNA SOLUTION. A KITCHEN SUITED TO ALL INTERPRETATIONS.



MY PLANET
DESIGN CR&S VARENNA.

LA CUCINA INTERPRETA IL DESIDERIO DIFFUSO DI PRATICITÀ E LEGGEREZZA. UNA SENSAZIONE SUGGERITA DA NUOVI COMPONENTI COME LE MANIGLIE E I TOP DI VARI SPESSORI, DALL'USO DELLA LUCE SUI PANNELLI ATTREZZATI, DALLE FINITURE WHITE E DARK PINE.

SOLUZIONI TECNICAMENTE EVOLUTE E COMPONENTI DAL DESIGN ESSENZIALE CHE GARANTISCONO, ANCHE IN CUCINE DI DIMENSIONI CONTENUTE, RISULTATI COMPOSITIVI ORIGINALI.



MY PLANET: THIS KITCHEN INTERPRETS THE WIDESPREAD DESIRE FOR PRACTICALITY AND ELEGANCE. A SENSATION SUGGESTED BY NEW COMPONENTS SUCH AS HANDLES AND COUNTERTOPS OF VARIOUS THICKNESSES, THE USE OF LIGHT EQUIPPED PANELS AND WHITE AND DARK PINE FINISHES.

TECHNICALLY EVOLVED SOLUTIONS AND FUNDAMENTAL DESIGN COMPONENTS THAT GUARANTEE ORIGINAL COMPOSITIONS FOR EVEN THE SMALLEST OF KITCHENS.



CRETA
DESIGN CARLO COLOMBO.

FINITURE: STRUTTURA LACCATO OPACO COLORI, WENGÉ E NOCE C.; SEDUTA E SCHIENALE TESSUTO E PELLE SFODERABILI.

DIMENSIONI MM:
L 450 P 410 H 880

FINISHING: STRUCTURE IN MAT LACQUERED COLOURS, WENGE AND WALNUT C.; SEAT AND BACK IN REMOVABLE FABRIC AND LEATHER.

DIMENSIONS IN:
W 17 3/4" D 16 1/4" H 34 5/8"



CRETA DUE PAG. 17-18-20
DESIGN CARLO COLOMBO.

FINITURE: SEDUTA E SCHIENALE IMBOTTITI E RIVESTIMENTO IN TESSUTO SFODERABILE CON FONDO PIEGA. GAMBE: LACCATO OPACO COLORI, WENGÉ E NOCE C.

DIMENSIONI MM:
L 450 P 410 H 880

FINISHING: UPHOLSTERED SEAT AND BACKREST REMOVABLE COVERING WITH FOLDS. LEGS: IN MAT LACQUERED COLOURS, WENGE AND WALNUT C.

DIMENSIONS IN:
W 17 3/4" D 16 1/4" H 34 5/8"



FLY DUE
DESIGN CARLO COLOMBO.

FINITURE: COMPLETAMENTE IMBOTTITA E RIVESTITA IN TESSUTO E PELLE SFODERABILI.

DIMENSIONI MM:
L 480 P 560 H 795

FINISHING: TOTALLY UPHOLSTERED AND COVERED IN REMOVABLE FABRIC AND LEATHER.

DIMENSIONS IN:
W 19" D 22" H 31 1/4"



FLY TRE
DESIGN CARLO COLOMBO.

FINITURE: COMPLETAMENTE IMBOTTITA E RIVESTITA IN TESSUTO E PELLE SFODERABILI.

DIMENSIONI MM:
L 510 P 550 H 850

FINISHING: TOTALLY UPHOLSTERED AND COVERED IN REMOVABLE FABRIC AND LEATHER.

DIMENSIONS IN:
W 20" D 21 3/4" H 33 7/16"



VALENTINA PAG. 170-173
DESIGN CARLO COLOMBO.

FINITURE: STRUTTURA IN FRASSINO TINTO WENGÉ E NOCE C.; SEDUTA E SCHIENALE TESSUTO E PELLE.

DIMENSIONI MM:
L 510 P 550 H 766

FINISHING: STRUCTURE IN WENGE DYED ASH AND WALNUT C.; SEAT AND BACK IN FABRIC AND LEATHER.

DIMENSIONS IN:
W 20" D 21 3/4" H 30 1/4"



VALENTINA DUE
DESIGN CARLO COLOMBO.

FINITURE: STRUTTURA IN FRASSINO TINTO WENGÉ E NOCE C.; SEDUTA TESSUTO E PELLE, SCHIENALE PAGLIA.

DIMENSIONI MM:
L 510 P 550 H 766

FINISHING: STRUCTURE IN WENGE DYED ASH AND WALNUT C.; SEAT IN FABRIC AND LEATHER, BACK IN STRAW.

DIMENSIONS IN:
W 20" D 21 3/4" H 30 1/4"



SCACCHI
DESIGN PAOLO PIVA.

FINITURE: WENGÉ CON SEDUTA IN TESSUTO; IN PELLE COMPLETAMENTE RIVESTITA.

DIMENSIONI MM:
L 465 P 450 H 860

FINISHING: WENGE WITH SEAT IN FABRIC; LEATHER, IN LEATHER IS COMPLETELY UPHOLSTERED.

DIMENSIONS IN:
W 18 1/4" D 17 3/4" H 33 3/4"



FLIP PAG. 143-144
DESIGN CARLO COLOMBO.

FINITURE: LACCATO OPACO PORO APERTO COLORI, FRASSINO TINTO WENGÉ E NOCE C.; SEDUTA IMBOTTITA E RIVESTITA IN TESSUTO E PELLE.

DIMENSIONI MM:
SEDIA
L 480 P 580 H 765
SEDIA CON BRACCIOLI
L 545 P 580 H 765

FINISHING: OPEN PORE MAT LACQUERED COLOURS, WENGE DYED ASH AND WALNUT C.; UPHOLSTERED SEAT WITH FABRIC OR LEATHER.

DIMENSIONS IN:
CHAIR
W 18 7/8" D 22 13/16" H 30 1/8"
CHAIR WITH ARMS
W 21 7/16" D 22 13/16" H 30 1/8"



VELVET PAG. 74-77-79
DESIGN CR&S POLIFORM.

FINITURE: SEDUTA E SCHIENALE
TESSUTO E PELLE SFODERABILI.
GAMBE WENGÉ E NOCE C.

DIMENSIONI MM:
SEDIA
L 575 P 590 H 770
SEDIA CON BRACCIOLI
L 575 P 590 H 770



FINISHING: SEAT AND BACK IN
REMOVABLE FABRIC AND LEATHER.
LEGS IN WENGÉ AND WALNUT C.

DIMENSIONS IN:
CHAIR
W 22 5/8" D 23 1/4" H 30 5/16"
CHAIR WITH ARMS
W 22 5/8" D 23 1/4" H 30 5/16"



MANTA PAG. 12-15
DESIGN RODRIGO TORRES.

FINITURE: COMPLETAMENTE
RIVESTITA IN PELLE.

DIMENSIONI MM:
SEDIA
L 520 P 530 H 770
SEDIA CON BRACCIOLI
L 570 P 550 H 770



FINISHING: COMPLETELY COVERED
IN LEATHER.

DIMENSIONS IN:
CHAIR
W 20 1/2" D 20 7/8" H 30 5/16"
CHAIR WITH ARMS
W 22 1/2" D 21 3/4" H 30 5/16"



STRIP PAG. 112-114-119-121
DESIGN CARLO COLOMBO.

FINITURE: SCOCCA IN PLASTICA
NEI COLORI BIANCO E NERO;
CUSCINO TESSUTO E PELLE
SFODERABILI. DISPONIBILE IN TRE
VERSIONI: CON BASE GIREVOLE A
RAZZE CON E SENZA RUOTE, IN
METALLO VERNICIATO BIANCO E
NERO O CON STRUTTURA IN
TUBOLARE METALLICO CROMATO.

DIMENSIONI MM:
L 600 P 570 H 720



FINISHING: BODY PLASTIC IN
WHITE AND BLACK;
CUSHION IN REMOVABLE FABRIC
AND LEATHER. AVAILABLE IN THREE
VERSIONS: WITH REVOLVING BASE
WITH OR WITHOUT WHEELS IN
VARNISHED METAL WHITE AND
BLACK OR WITH STRUCTURE IN
CHROMED METAL TUBULAR.

DIMENSIONS IN:
W 23 1/2" D 22 1/2" H 28 1/4"



STRIP IN PELLE PAG. 83
DESIGN CARLO COLOMBO.

FINITURE: SCOCCA IN PELLE .
DISPONIBILE IN TRE VERSIONI:
CON BASE GIREVOLE A RAZZE
CON E SENZA RUOTE,
IN METALLO VERNICIATO BIANCO E
NERO O CON STRUTTURA IN
TUBOLARE METALLICO CROMATO.

DIMENSIONI MM:
L 600 P 570 H 720



STRIP IN LEATHER. FINISHING:
BODY LEATHER. AVAILABLE IN
THREE VERSIONS: WITH REVOLVING
BASE WITH OR WITHOUT WHEELS
IN VARNISHED METAL WHITE AND
BLACK OR WITH STRUCTURE IN
CHROMED METAL TUBULAR.

DIMENSIONS IN:
W 23 1/2" D 22 1/2" H 28 1/4"



SWEET PAG. 53-55
DESIGN STUDIO KAIROS.

FINITURE: STRUTTURA
IN METALLO CROMATO;
SEDUTA E SCHIENALE TESSUTO
SFODERABILE E PELLE.

DIMENSIONI MM:
L 460 P 530 H 750

FINISHING: STRUCTURE IN
CHROMED METAL; SEAT AND BACK
IN REMOVABLE FABRIC AND
LEATHER.

DIMENSIONS IN:
W 18 1/8" D 20 7/8" H 29 1/2"



BB
DESIGN RICCARDO BLUMER
E MATTEO BORGHI.

FINITURE: COMPLETAMENTE
RIVESTITA IN CUOIO.

DIMENSIONI MM:
L 490 P 580 H 767

FINISHING: COMPLETELY COVERED
IN HIDE LEATHER.

DIMENSIONS IN:
W 19 5/16" D 22 13/16" H 30 3/16"



S60



S61



S60B



S61B

NEX
DESIGN MARIO MAZZER.

FINITURE STRUTTURA: S60, S60B
E S64 IN TUBOLARE DI FERRO
CROMATO;
S61 E S61B IN TONDINO DI FERRO
CROMATO O ACCIAIO INOX.
SEDUTA E SCHIENALE IN LEGNO
FINITURA WENGÉ; IN MATERIALE
PLASTICO NEI COLORI BIANCO 01,
CANAPA 35 E GRAFITE 04,
DISPONIBILE ANCHE RIVESTITA
NON SFODERABILE IN TESSUTO
E PELLE.

DIMENSIONI MM:
S60-S60B
L 500 P 535 H 740
S61-S61B
L 500 P 505 H 740
S64
L 510 P 505 H 950

FINISHING STRUCTURE: S60, S60B
AND S64 IN TUBULAR CHROMED
METAL;
S61 AND S61B IN CHROMED METAL
ROUND BAR OR INOX STEEL.
SEAT AND BACK IN WOOD,
FINISHING WENGÉ; IN PLASTIC
MATERIAL, COLOURS WHITE 01,
CANAPA 35 AND GRAFITE 04,
AVAILABLE ALSO COVERED
IN NOT REMOVABLE FABRIC
OR LEATHER.

DIMENSIONS IN:
S60-S60B
W 19 3/4" D 21 1/16" H 29 1/4"
S61-S61B
W 19 3/4" D 19 7/8" H 29 1/4"
S64
W 20 1/16" D 19 7/8" H 29 1/4"

S64





DOLMEN
DESIGN CARLO COLOMBO.

TAVOLO ALLUNGABILE.
FINITURE: LACCATO OPACO
COLORI, WENGÉ E NOCE C.

DIMENSIONI MM:
1900/2500 x 900 H 740

EXTENSIBLE TABLE.
FINISHING: MAT LACQUERED
COLOURS, WENGE AND WALNUT C.

DIMENSIONS IN:
74 3/4"/98 1/2" x 35 1/2" H 29 1/4"



DOLMEN DUE
DESIGN CARLO COLOMBO.

TAVOLO VERSIONE FISSA.
FINITURE: LACCATO OPACO
COLORI, WENGÉ E NOCE C.,
PIANO DISPONIBILE ANCHE
IN VETRO E PIETRA.

DIMENSIONI MM:
1500 x 1500 H 740
2200 x 1100 H 740

FIXED TABLE.
FINISHING: MAT LACQUERED
COLOURS, WENGE AND
WALNUT C., TOP AVAILABLE
ALSO IN GLASS AND STONE.

DIMENSIONS IN:
59 1/16" x 59 1/16" H 29 1/4"
86 1/2" x 43 5/16" H 29 1/4"



TAGLIO PAG. 12-13
DESIGN EMMANUEL GALLINA.

TAVOLO ALLUNGABILE.
FINITURE: WENGÉ E NOCE C.

DIMENSIONI MM:
1900/2530 x 950 H 740

EXTENSIBLE TABLE.
FINISHING: WENGE AND WALNUT C.

DIMENSIONS IN:
74 3/4"/99 5/8" x 37 1/2" H 29 1/4"



ZEUS PAG. 18-20-74-77-79
DESIGN VINCENT VAN DUYSSEN.

FINITURE: WENGÉ E NOCE C.

DIMENSIONI MM:
1800 x 1800 H 740
2200 x 1080 H 740
2700 x 1080 H 740

FINISHING: WENGE AND WALNUT C.

DIMENSIONS IN:
70 7/8" x 70 7/8" H 29 1/4"
86 1/2" x 42 1/2" H 29 1/4"
106 5/16" x 42 1/2" H 29 1/4"



MASTER
DESIGN CR&S POLIFORM.

TAVOLO ALLUNGABILE.
FINITURE: LACCATO OPACO
COLORI, WENGÉ E NOCE C.

DIMENSIONI MM:
1000/1760 x 1000 H 740
1550/2200 x 860 H 740
1800/2450 x 860 H 740

EXTENSIBLE TABLE.
FINISHING: MAT LACQUERED
COLOURS, WENGE AND WALNUT C.

DIMENSIONS IN:
39 1/4"/69 5/16" x 39 1/4" H 29 1/4"
61"/86 1/2" x 33 3/4" H 29 1/4"
70 3/4"/96 1/2" x 33 3/4" H 29 1/4"



MASTER DUE
DESIGN CR&S POLIFORM.

TAVOLO ALLUNGABILE.
FINITURE: LACCATO OPACO
COLORI, WENGÉ E NOCE C.

DIMENSIONI MM:
1000/1760 x 1000 H 740
1550/2200 x 860 H 740
1800/2450 x 860 H 740

EXTENSIBLE TABLE.
FINISHING: MAT LACQUERED
COLOURS, WENGE AND WALNUT C.

DIMENSIONS IN:
39 1/4"/69 5/16" x 39 1/4" H 29 1/4"
61"/86 1/2" x 33 3/4" H 29 1/4"
70 3/4"/96 1/2" x 33 3/4" H 29 1/4"



ASTRID PAG. 143-144
DESIGN ROBERTO LAZZERONI.

FINITURE: WENGÉ.

DIMENSIONI MM:
2400 x 1000 H 740

BASE CONICA
Ø 1250 H 740
Ø 1500 H 740

FINISHING: WENGE.

DIMENSIONS IN:
94 1/2" x 39 3/8" H 29 1/4"

CONE-SHAPED BASE
Ø 49 1/4" H 29 1/4"
Ø 59 1/16" H 29 1/4"





EASY PAG. 53-55
DESIGN CARLO COLOMBO.

FINITURE: LACCATO OPACO
COLORI, LACCATO LUCIDO
COLORI, WENGÉ E NOCE C.;
STRUTTURA IN PIATTO
DI FERRO CROMATO.

DIMENSIONI MM:
2200 x 950 H 740
2600 x 1000 H 740

FINISHING: MAT LACQUERED
COLOURS, GLOSSY LACQUERED
COLOURS, WENGE AND WALNUT
C.; FRAME IN CHROMED PLATE
STEEL.

DIMENSIONS IN:
86 1/2" x 37 1/2" H 29 1/4"
102 1/4" x 39 1/4" H 29 1/4"



ARTONE DUE PAG. 170-173
DESIGN PAOLO PIVA.

FINITURE: LACCATO OPACO
COLORI, WENGÉ E NOCE C.

DIMENSIONI MM:
2200 x 950 H 730
2600 x 1000 H 730

FINISHING: MAT LACQUERED
COLOURS, WENGE AND WALNUT C.

DIMENSIONS IN:
86 1/2" x 37 1/2" H 28 3/4"
102 1/4" x 39 1/4" H 28 3/4"



TREVI PAG. 113-114-119
DESIGN ROBERTO BARBIERI.

FINITURE: PIANO LACCATO OPACO
COLORI E IN VERSIONE
ANTIGRAFFIO NEI COLORI
BIANCO 01, CANAPA 35
E GRAFITE 04;
GAMBE IN ALLUMINIO BRILL,
LACCATO OPACO COLORI
E IN VERSIONE ANTIGRAFFIO.

DIMENSIONI MM:
900 x 900 H 740
1250 x 1250 H 740
1400 x 800 H 740
1800 x 900 H 740

FINISHING: TOP IN MAT
LACQUERED COLOURS
AND IN ANTISCRATCH VERSION IN
COLOURS WHITE 01, CANAPA 35
AND GRAFITE 04;
LEGS IN ALUMINIUM BRILL,
MAT LACQUERED COLOURS
AND IN ANTISCRATCH VERSION.

DIMENSIONS IN:
35 7/16" x 35 7/16" H 29 1/4"
49 3/16" x 49 3/16" H 29 1/4"
55 1/8" x 31 1/2" H 29 1/4"
70 7/8" x 35 7/16" H 29 1/4"



MADRAS
DESIGN CARLO COLOMBO.

FINITURE: LACCATO OPACO
COLORI E IN VERSIONE
ANTIGRAFFIO NEI COLORI BIANCO
01, CANAPA 35 E GRAFITE 04.
PIANO DISPONIBILE ANCHE IN
MARMO BIANCO CARRARA E
GRANITO NERO ASSOLUTO.

DIMENSIONI MM:
2100 x 1000 H 740
Ø 1250 H 740



FINISHING: MAT LACQUERED
COLOURS AND IN ANTISCRATCH
VERSION IN COLOURS WHITE 01,
CANAPA 35 AND GRAFITE 04.
TOP AVAILABLE ALSO IN WHITE
CARRARA MARBLE AND ABSOLUTE
BLACK GRANITE.

DIMENSIONS IN:
82 11/16" x 39 3/8" H 29 1/4"
Ø 49 3/16" H 29 1/4"



LINK PAG. 53-119
DESIGN CARLO COLOMBO.

FINITURE: LACCATO OPACO
COLORI, LACCATO LUCIDO
COLORI, WENGÉ E NOCE C.

DIMENSIONI MM:
2 ANTE SCORREVOLI COMPLANARI
L 2340 P 540 H 638
4 ANTE BATTENTI
L 2490 P 540 H 638
CON BASAMENTO H 660

FINISHING: MAT LACQUERED
COLOURS, GLOSSY LACQUERED
COLOURS, WENGE AND WALNUT C.

DIMENSIONS IN:
2 COPLANAR SLIDING DOORS
W 92 1/8" D 21 1/4" H 25 1/8"
4 LEAF DOORS
W 98" D 21 1/4" H 25 1/8"
WITH LEGS H 26"

MAX
DESIGN PAOLO PIVA.

FINITURE: LACCATO
OPACO COLORI, LACCATO
LUCIDO COLORI, WENGÉ
E NOCE C.

DIMENSIONI MM:
L 2300 P 600 H 550
CON ZOCCOLO H 475

FINISHING: MAT LACQUERED
COLOURS, GLOSSY
LACQUERED COLOURS, WENGE
AND WALNUT C.

DIMENSIONS IN:
W 90 1/2" D 23 1/2" H 21 5/8"
WITH PLINTH H 18 3/4"



TEIA PAG. 12-15-144
DESIGN STUDIO KAIROS.

FINITURE: LACCATO
OPACO COLORI, LACCATO
LUCIDO COLORI, WENGÉ
E NOCE C.

DIMENSIONI MM:
4 ANTE BATTENTI APERTURA 180°
L 2457 P 629 H 570
2 ANTE BATTENTI APERTURA 180°,
1 CASSETTO, VANO GIORNO
L 2457 P 629 H 570

FINISHING: MAT LACQUERED
COLOURS, GLOSSY
LACQUERED COLOURS, WENGE
AND WALNUT C.

DIMENSIONS IN:
4 LEAF DOORS OPENING 180°
W 94 3/4" D 24 3/4" H 22 7/16"
2 LEAF DOORS OPENING 180°,
1 DRAWER, OPEN SPACE
W 94 3/4" D 24 3/4" H 22 7/16"



DIMENSIONI MM:
2 ANTE BATTENTI APERTURA 180°,
3 CASSETTI
L 1970 P 500 H 850
2 ANTE BATTENTI APERTURA 180°,
L 1089 P 500 H 1000

DIMENSIONS IN:
2 LEAF DOORS OPENING 180°,
3 DRAWERS
W 77 9/16" D 19 11/16" H 33 7/16"
2 LEAF DOORS OPENING 180°,
W 42 7/8" D 19 11/16" H 39 3/8"



SLIM PAG. 170
DESIGN PAOLO PIVA.

FINITURE: LACCATO OPACO
COLORI, LACCATO LUCIDO COLORI
E WENGÉ.

DIMENSIONI MM:
3 ANTE BATTENTI
L 2085 P 540 H 640
4 ANTE BATTENTI
L 2770 P 540 H 640
SLIM ALTA 4 ANTE BATTENTI
L 1400 P 540 H 1188
CON PIEDINI H 725
SLIM ALTA CON PIEDINI H 1273

FINISHING: MAT LACQUERED
COLOURS, GLOSSY LACQUERED
COLOURS AND WENGE.

DIMENSIONS IN:
3 LEAF DOORS
W 82 1/8" D 21 1/4" H 25 1/4"
4 LEAF DOORS
W 109" D 21 1/4" H 25 1/4"
TALL SLIM 4 LEAF DOORS
W 55 1/8" D 21 1/4" H 46 3/4"
WITH LEGS H 28 1/2"
TALL SLIM WITH LEGS H 50 1/8"



TEIA PAG. 67-68-79-146
DESIGN STUDIO KAIROS.

FINITURE: LACCATO
OPACO COLORI, LACCATO
LUCIDO COLORI, WENGÉ
E NOCE C.

DIMENSIONI MM:
1 CASSETTO, 2 RIPIANI
L 1089 P 500 H 1550
2 ANTE VETRO FUMÉ
E 3 RIPIANI INTERNI
L 1089 P 500 H 1550
1 CASSETTO, 2 ANTE
E 1 RIPIANO INTERNO
L 1089 P 500 H 1550

FINISHING: MAT LACQUERED
COLOURS, GLOSSY
LACQUERED COLOURS, WENGE
AND WALNUT C.

DIMENSIONS IN:
1 DRAWER, 2 SHELVES
W 42 7/8" D 19 11/16" H 61"
2 FUMÉ GLASS DOORS
AND 3 INNER SHELVES
W 42 7/8" D 19 11/16" H 61"
1 DRAWER, 2 DOORS
AND 1 INNER SHELF
W 42 7/8" D 19 11/16" H 61"



DUNE PAG. 4-6-8-10-22
DESIGN CARLO COLOMBO.

STRUTTURA: POLIURETANO FLESSIBILE STAMPATO CON INSERTI IN POLIURETANO ESPANSO A QUOTE DIFFERENZIALI. IMBOTTITURA SEDUTA: POLIURETANO ESPANSO A QUOTE DIFFERENZIALI. PRERIVESTIMENTO VERSIONE OVATTA: OVATTA DI POLIESTERE ACCOPPIATA.

PRERIVESTIMENTO VERSIONE PIUMA: PARTI IN TELA COTONE CON INTERNO IN PIUMA E PARTI IN OVATTA DI POLIESTERE ACCOPPIATA. PIEDI: SCIVOLI IN MATERIALE PLASTICO. RIVESTIMENTO FINALE TESATO: SFODERABILE IN TESSUTO E NON SFODERABILE IN PELLE. CUSCINATURA: IN PIUMA, SFODERABILE IN TESSUTO E PELLE, CON PRERIVESTIMENTO IN COTONE.

STRUCTURE:FLEXIBLE PRINTED POLYURETHANE WITH PARTS IN POLYURETHANE OF DIFFERENT DENSITIES. SEAT PADDING: FOAMED POLYURETHANE OF DIFFERENT DENSITIES. PRE-COVERING PADDING VERSION: POLYESTER PADDING. PRE-COVERING FEATHER VERSION: PARTS IN COTTON CLOTH WITH FEATHER INSIDE AND PARTS IN POLYESTER PADDING.

FEET: CHUTES IN PLASTIC MATERIAL. FINAL OUTSTRETCHED COVERING: REMOVABLE IN FABRIC AND NON-REMOVABLE IN LEATHER. CUSHIONS: IN FEATHER, REMOVABLE IN FABRIC AND LEATHER WITH PRE-COVERING IN COTTON.

DIVANI FISSI SOFAS

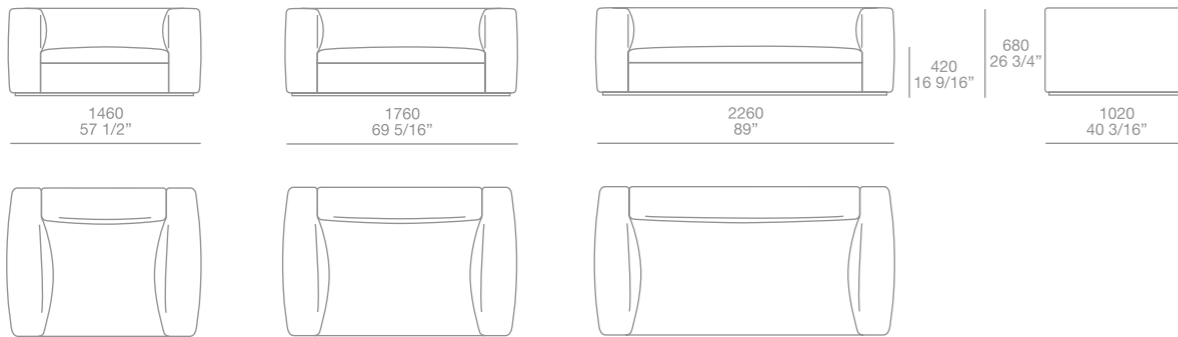

POLTRONA ARMCHAIR

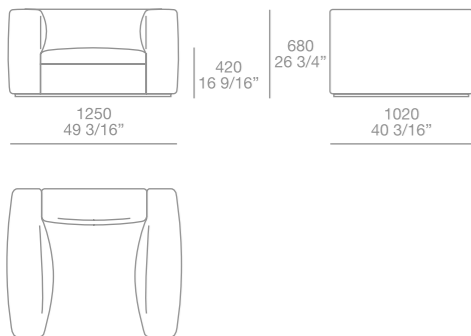

POUF

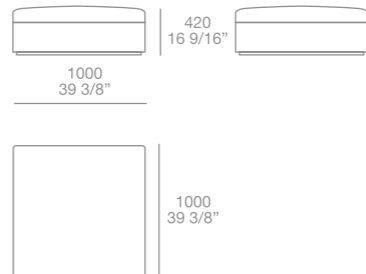

TERMINALI SX-DX
END UNITS LEFT-RIGHT

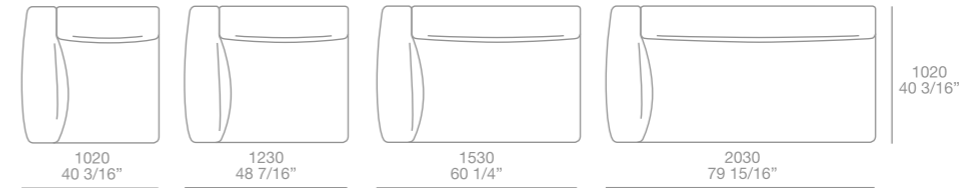

TERMINALI PENISOLA SX-DX
CHAISE LONGUE END UNITS LEFT-RIGHT

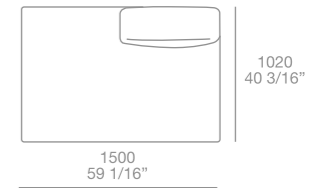

CENTRALI O TERMINALI SENZA BRACCIOLO SX-DX
UNITS OR END UNITS WITHOUT LEFT-RIGHT ARM

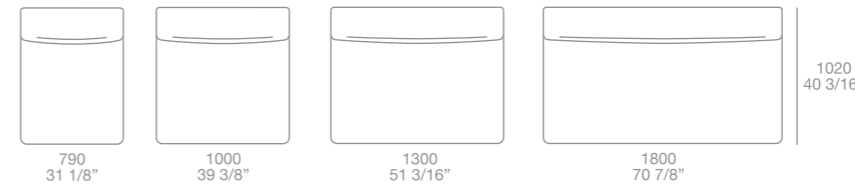

POUF



ANGOLI DX-SX
CORNERS RIGHT-LEFT

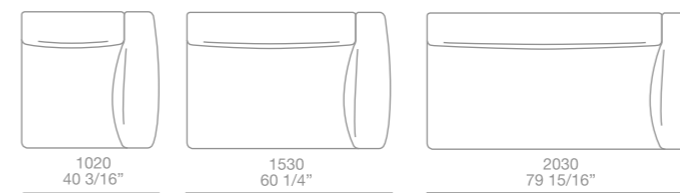

CHAISE LONGUE SX-DX
LEFT-RIGHT

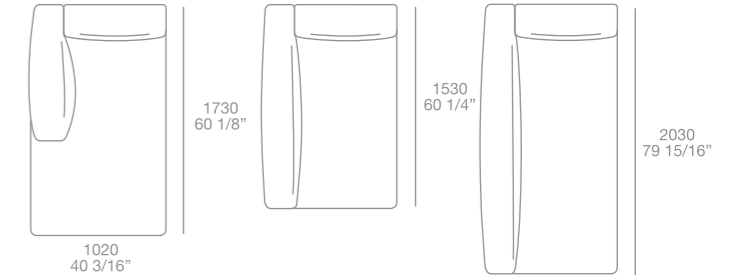

TERMINALI ANGOLARE SX-DX
END UNITS LEFT-RIGHT

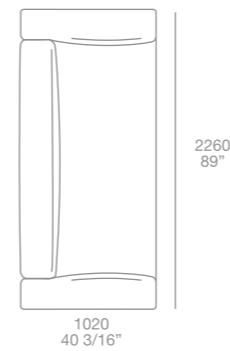

CUSCINI
CUSHIONS

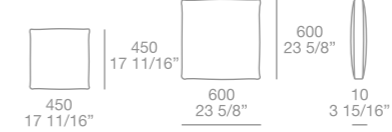



SHANGAI PAG. 41-42-44-159-162
DESIGN CARLO COLOMBO.

SISTEMA DI DIVANI FISSI E
COMPONIBILI.
STRUTTURA: LEGNO E DERIVATI.
IMBOTTITURA STRUTTURA, SEDUTA
E SCHIENALE: POLIURETANO
ESPANSO A QUOTE
DIFFERENZIATE.
PRERIVESTIMENTO: OVATTA DI
POLIESTERE ACCOPPIATA.
PIEDI: SCIVOLI IN MATERIALE
PLASTICO.

BASAMENTO: ALLUMINIO BRILL.
RIVESTIMENTO FINALE TESSATO:
SFODERABILE IN TESSUTO E NON
SFODERABILE IN PELLE.
CUSCINATURA: IN PIUMA,
SFODERABILE IN TESSUTO E
PELLE, CON PRERIVESTIMENTO
IN COTONE.

SOFAS AND SECTIONAL SOFAS
SYSTEM.
STRUCTURE: WOOD AND WOOD
BY-PRODUCTS.
PADDING: FOAMED POLYURETHANE
OF DIFFERENT DENSITIES.
PRE-COVERING: POLYESTER
PADDING.
FEET: CHUTES IN PLASTIC
MATERIAL.

BASEMENT: BRILL ALUMINIUM.
FINAL OUTSTRETCHED COVERING:
REMOVABLE
IN FABRIC AND NON-REMOVABLE IN
LEATHER.
CUSHIONS: IN FEATHER,
REMOVABLE IN FABRIC AND
LEATHER, WITH COTTON PRE-
COVERING.

**DIVANI FISSI
SOFAS**

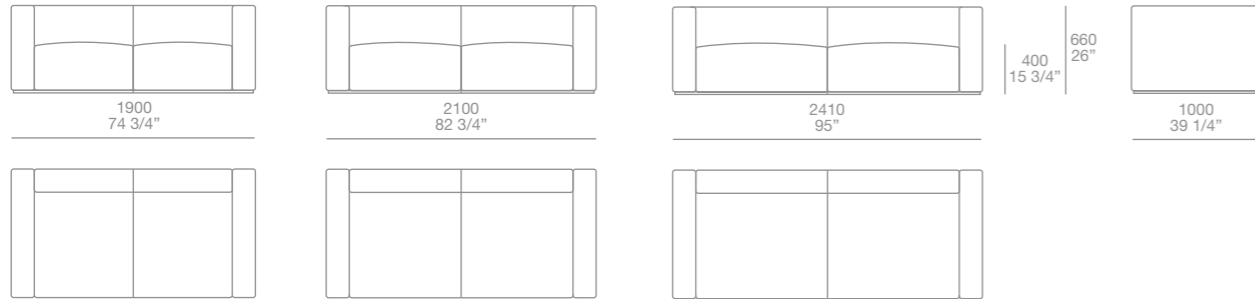

**POLTRONA
ARMCHAIR**

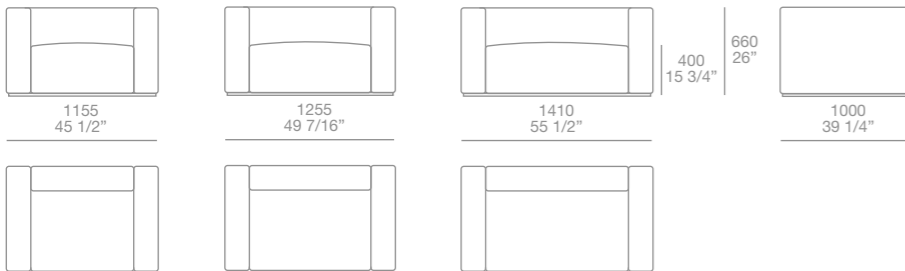

**POLTRONCINA
SMALL ARMCHAIR**

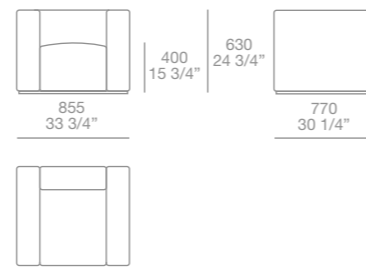

**CUSCINI
CUSHIONS**

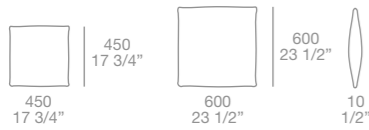

POUF

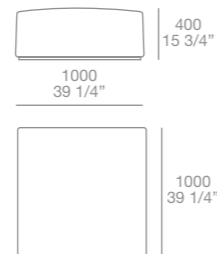

**TERMINALI SX-DX
END UNITS LEFT-RIGHT**

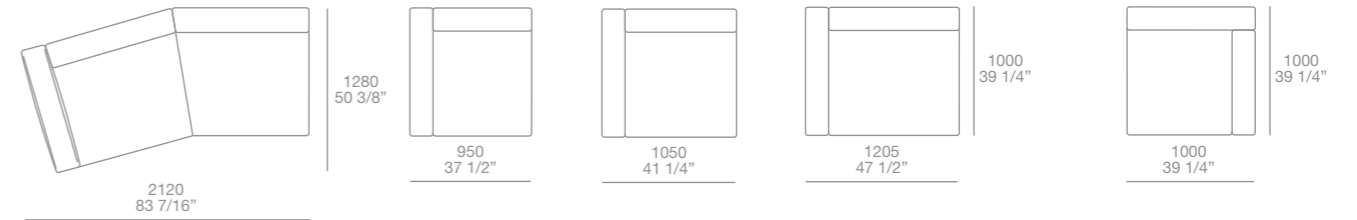

**ANGOLO
CORNER**

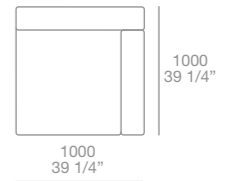

**CENTRALI O TERMINALI SENZA BRACCIOLO SX-DX
UNITS OR END UNITS WITHOUT LEFT-RIGHT ARM**



**CHAISE LONGUE SX-DX
LEFT-RIGHT**

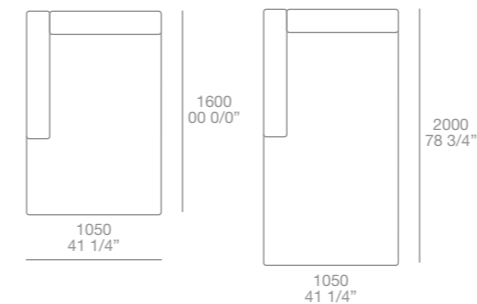

POUF

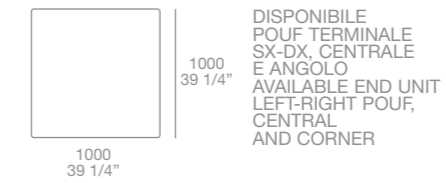

DISPONIBILE
POUF TERMINALE
SX-DX, CENTRALE
E ANGOLO
AVAILABLE END UNIT
LEFT-RIGHT POUF,
CENTRAL
AND CORNER



CANYON PAG. 67-68-70-79
DESIGN PAOLA NAVONE.

SISTEMA DI DIVANI FISSI E
COMPONIBILI.
STRUTTURA: LEGNO E DERIVATI.
IMBOTTITURA STRUTTURA, SEDUTA
E SCHIENALE: POLIURETANO
ESPANSO A QUOTE
DIFFERENZIATE.
PRERIVESTIMENTO: OVATTA DI
POLIESTERE ACCOPPIATA.
PIEDI: SCIVOLI IN MATERIALE
PLASTICO.

RIVESTIMENTO FINALE TESATO:
SFODERABILE IN TESSUTO E
NON SFODERABILE IN PELLE.
CUSCINATURA: IN PIUMA,
SFODERABILE IN TESSUTO E
PELLE, CON PRERIVESTIMENTO IN
COTONE.

SOFAS AND SECTIONAL SOFAS
SYSTEM.
STRUCTURE: WOOD AND WOOD
BY-PRODUCTS.
STRUCTURE, SEAT AND BACK
PADDING: FOAMED POLYURETHAN
OF DIFFERENT DENSITIES.
PRE-COVERING: POLYESTER
PADDING.
FEET: CHUTES IN PLASTIC
MATERIAL.

FINAL OUTSTRETCHED COVERING:
REMOVABLE IN FABRIC AND
NON-REMOVABLE IN LEATHER.
CUSHIONS: IN FEATHER,
REMOVABLE IN FABRIC AND
LEATHER, WITH COTTON
PRE-COVERING.

DIVANI FISSI
SOFAS

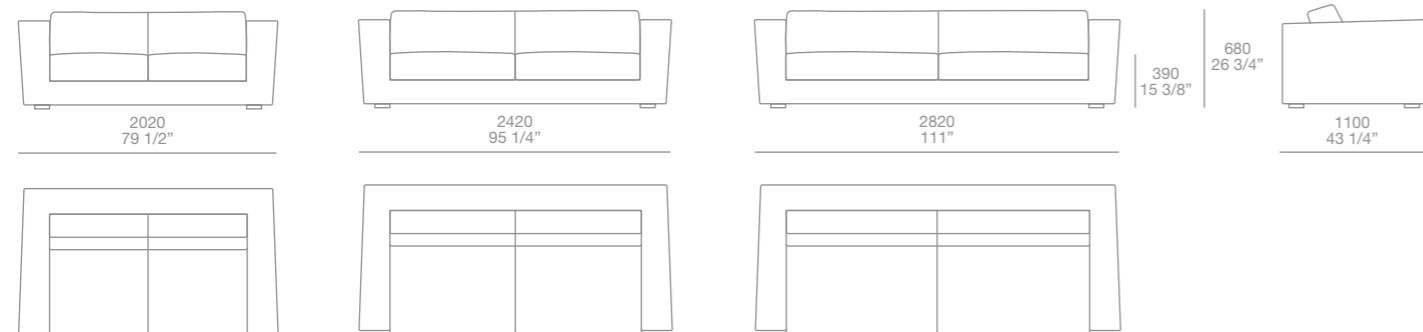

POLTRONA
ARMCHAIR

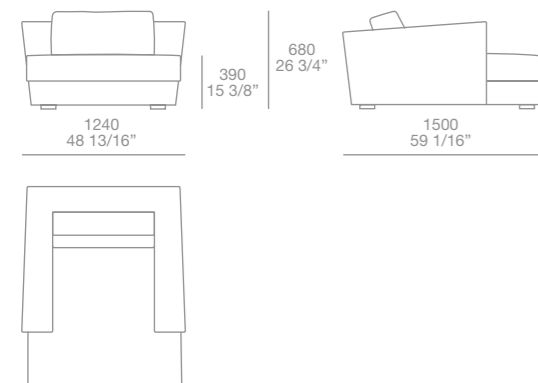

CUSCINI
CUSHIONS

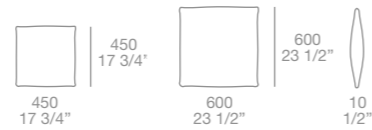

TERMINALI SX-DX
END UNITS LEFT-RIGHT

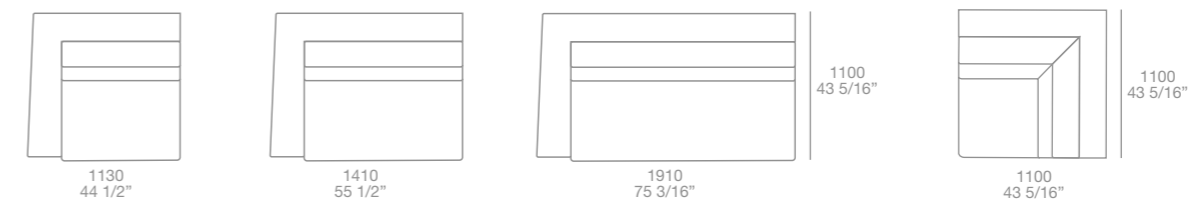

ANGOLO
CORNER

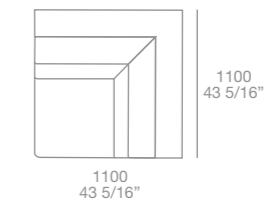

CENTRALI
UNITS



CHAISE LONGUE SX-DX
LEFT-RIGHT

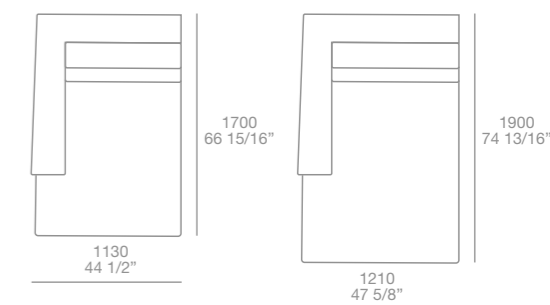

POUF

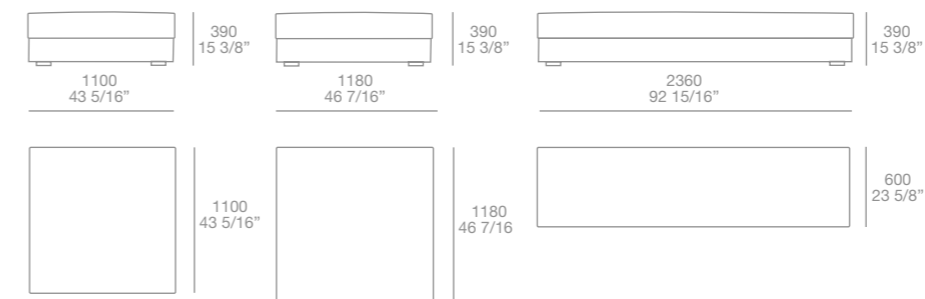



AIRPORT PAG. 103-104
DESIGN PAOLA NAVONE.

DIVANI DISPONIBILI CON O SENZA CUSCINI SCHIENALE NELLE 3 DIMENSIONI. STRUTTURA: LEGNO E DERIVATI. IMBOTTITURA STRUTTURA, SEDUTA E SCHIENALE: POLIURETANO ESPANSO A QUOTE DIFFERENZiate. PRERIVESTIMENTO: OVATTA DI POLIESTERE ACCOPPIATA.

PIEDI: SCIVOLI IN MATERIALE PLASTICO. RIVESTIMENTO FINALE NON TESATO: SFODERABILE IN TESSUTO. CUCITURA: DOPPIA OVERLOCK. CUSCINATURA: IN PIUMA, SFODERABILE IN TESSUTO, CON PRERIVESTIMENTO IN COTONE.

SOFAS AVAILABLE WITH OR WITHOUT BACK CUSHION IN THREE DIMENSIONS. STRUCTURE: WOOD AND WOOD BY-PRODUCTS. PADDING OF STRUCTURE, SEAT AND BACK: FOAMED POLYURETHANE OF DIFFERENT DENSITIES. PRE-COVERING: POLYESTER PADDING.

FEET: PLASTIC MATERIAL. FINAL NOT OUTSTRETCHED COVERING: REMOVABLE IN FABRIC. SEWING: DOUBLE OVERLOCK. CUSHIONS: IN FEATHER, REMOVABLE IN FABRIC, WITH COTTON PRE-COVERING.

DIVANI FISSI
SOFAS

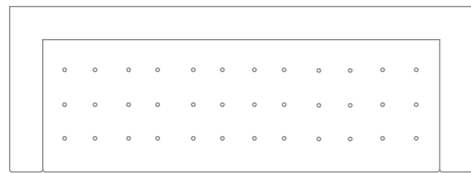
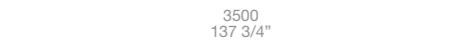
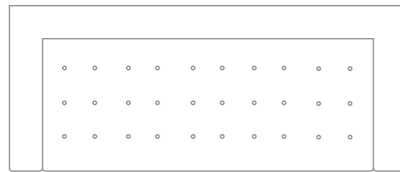
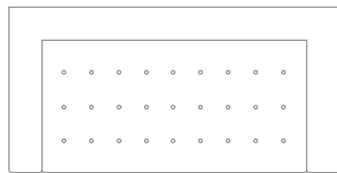
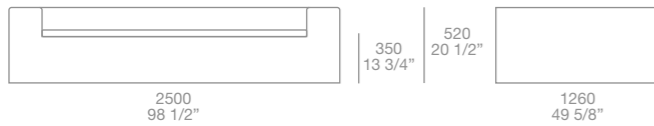

ATOLLO PAG. 131-132
DESIGN PAOLA NAVONE.

STRUTTURA: LEGNO E DERIVATI. IMBOTTITURA STRUTTURA, SEDUTA E SCHIENALE: POLIURETANO ESPANSO A QUOTE DIFFERENZiate. PRERIVESTIMENTO: OVATTA DI POLIESTERE ACCOPPIATA. PIEDI: SCIVOLI IN MATERIALE PLASTICO. RIVESTIMENTO FINALE TESATO: SFODERABILE IN TESSUTO E NON SFODERABILE IN PELLE.

RIVESTIMENTO FINALE NON TESATO: SFODERABILE IN TESSUTO. CUCITURA: DOPPIA OVERLOCK SOLO PER RIVESTIMENTO IN TESSUTO. CUSCINATURA: IN PIUMA, SFODERABILE IN TESSUTO, CON PRERIVESTIMENTO IN COTONE.

STRUCTURE: WOOD AND WOOD BY-PRODUCTS. STRUCTURE, SEAT AND BACK PADDING: FOAMED POLYURETHANE OF DIFFERENT DENSITIES. PRE-COVERING: POLYESTER PADDING. FEET: CHUTES IN PLASTIC MATERIAL. FINAL OUTSTRETCHED COVERING: REMOVABLE IN FABRIC AND NON-REMOVABLE IN LEATHER.

FINAL NOT OUTSTRETCHED COVERING: REMOVABLE IN FABRIC. SEWING: DOUBLE OVERLOCK ONLY FOR FABRIC COVERING. CUSHIONS: IN FEATHER, REMOVABLE IN FABRIC, WITH COTTON PRE-COVERING.

DIVANI FISSI
SOFAS

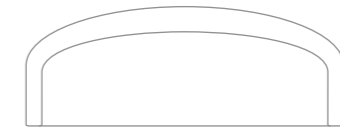
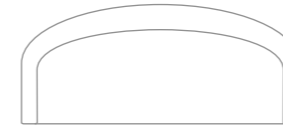
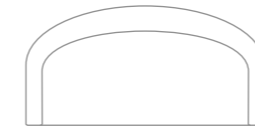
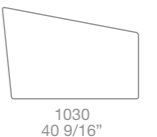
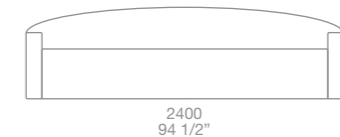
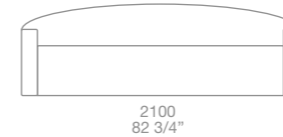
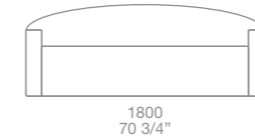

POLTRONA
ARMCHAIR

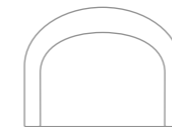
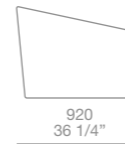
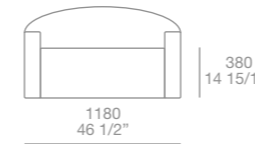

POUF



POUF

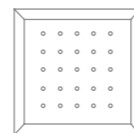

CUSCINI
CUSHIONS

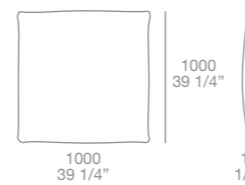
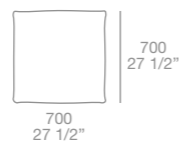

CUSCINI
CUSHIONS

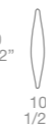



BALI PAG. 107
DESIGN CARLO COLOMBO.

FINITURE: BASAMENTO IN METALLO CROMATO.
RIVESTIMENTO FINALE TESATO: SFODERABILE IN TESSUTO E NON SFODERABILE IN PELLE.

DIMENSIONI MM:
POLTRONA
L 820 P 880 H 710
POGGIAPIEDI
L 730 P 600 H 360



FINISHING: BASE IN CHROMED METAL.
FINAL OUTSTRETCHED COVERING: REMOVABLE IN FABRIC AND NON-REMOVABLE IN LEATHER.

DIMENSIONS IN:
ARMCHAIR
W 32 1/4" D 34 5/8" H 27 15/16"
FOOT-REST
W 28 3/4" D 23 5/8" H 14 3/16"



SNAKE PAG. 4-6-8-10-41-42
DESIGN ROBERTO LAZZERONI.

STRUTTURA: POLIURETANO FLESSIBILE STAMPATO.
PRERIVESTIMENTO: OVATTA DI POLIESTERE ACCOPPIATA.
RIVESTIMENTO FINALE TESATO: NON SFODERABILE IN PELLE.
PIASTRA GIREVOLE: METALLO VERNICIATO.

DIMENSIONI MM:
POLTRONA
L 650 P 860 H 780
POGGIAPIEDI
L 650 P 550 H 375

STRUCTURE: FLEXIBLE PRINTED POLYURETHANE.
PRE-COVERING: POLYESTER PADDING.
FINAL OUTSTRETCHED COVERING: NON-REMOVABLE IN LEATHER.
REVOLVING PLATE: VARNISHED METAL.

DIMENSIONS IN:
ARMCHAIR
W 25 9/16" D 33 7/8" H 30 11/16"
FOOT-REST
W 25 9/16" D 21 5/8" H 14 3/4"



FLIP PAG. 146-148-154-179-181
DESIGN CARLO COLOMBO.

FINITURE: LACCATO OPACO PORO APERTO COLORI, FRASSINO TINTO WENGÉ E NOCE C.; SEDUTA IMBOTTITA.
RIVESTIMENTO FINALE TESATO: NON SFODERABILE IN TESSUTO E PELLE.

DIMENSIONI MM:
POLTRONCINA
L 630 P 680 H 665
POGGIAPIEDI
L 590 P 380 H 370



FINISHING: OPEN PORE MAT LACQUERED COLOURS, WENGE AND WALNUT C. DYED ASH; UPHOLSTERED SEAT. FINAL OUTSTRETCHED COVERING: NON-REMOVABLE IN FABRIC AND LEATHER.

DIMENSIONS IN:
SMALL ARMCHAIR
W 24 13/16" D 26 3/4" H 26 3/16"
FOOT-REST
W 23 1/4" D 14 15/16" H 14 9/16"



CAMILLA PAG. 86-87
DESIGN CR&S POLIFORM.

FINITURE: FRASSINO TINTO WENGÉ E NOCE C. RIVESTIMENTO FINALE TESATO: SFODERABILE IN TESSUTO E PELLE.

DIMENSIONI MM:
L 715 P 785 H 760



FINISHING: WENGE AND WALNUT C. DYED ASH. FINAL OUTSTRETCHED COVERING: REMOVABLE IN FABRIC AND LEATHER.

DIMENSIONS IN:
W 28 1/4" D 31" H 30"



BUG PAG. 24-37
DESIGN PAOLA NAVONE.

STRUTTURA: POLIURETANO FLESSIBILE STAMPATO CON PARTI IN POLIURETANO ESPANSO A QUOTE DIFFERENZIALI.
PRERIVESTIMENTO: OVATTA DI POLIESTERE ACCOPPIATA.
PIEDI: SCIVOLI IN MATERIALE PLASTICO.
RIVESTIMENTO FINALE TESATO: SFODERABILE IN TESSUTO E NON SFODERABILE IN PELLE.

DIMENSIONI MM:
L 905 P 1100 H 730

STRUCTURE: FLEXIBLE PRINTED POLYURETHANE WITH ELEMENTS IN FOAMED POLYURETHANE OF DIFFERENT DENSITIES.
PRE-COVERING: POLYESTER PADDING.
FEET: PLASTIC MATERIAL.
FINAL OUTSTRETCHED COVERING: REMOVABLE IN FABRIC AND NON-REMOVABLE IN LEATHER.

DIMENSIONS IN:
W 35 5/8" D 43 5/16" H 28 3/4"



PLAY SEDUTE IMBOTTITE
PAG. 66-86-99-108-118-123-134-153
DESIGN VITTORIO PRATO.

FINITURE: RIVESTIMENTO FINALE TESATO: SFODERABILE IN TESSUTO E NON SFODERABILE IN PELLE.
RIVESTIMENTO FINALE CON FONDO PIEGA: SFODERABILE IN TESSUTO E PELLE.

DIMENSIONI MM:
L 400 P 400 H 400
L 1200 P 1200 H 300
Ø 1200 H 300

PADDED CHAIRS. FINISHING: FINAL OUTSTRETCHED COVERING: REMOVABLE IN FABRIC AND NON-REMOVABLE IN LEATHER. FINAL COVERING WITH FOLDS: REMOVABLE IN FABRIC AND LEATHER.

DIMENSIONS IN:
W 15 3/4" D 15 3/4" H 15 3/4"
W 47 1/4" D 47 1/4" H 11 3/4"
Ø 47 1/4" H 11 3/4"



ARTONE PAG. 44-159
DESIGN PAOLO PIVA.

FINITURE: LACCATO OPACO
COLORI, LACCATO LUCIDO
COLORI E WENGÉ.
PIEDINI IN ACCIAIO INOX.

DIMENSIONI MM:
1000 x 1000 H 184
1200 x 1200 H 184
1400 x 700 H 184

FINISHING: MAT LACQUERED
COLOURS, GLOSSY LACQUERED
COLOURS AND WENGE.
FEET IN STAINLESS STEEL.

DIMENSIONS IN:
39 3/8" x 39 3/8" H 7 1/4"
47 1/4" x 47 1/4" H 7 1/4"
55" x 27 1/2" H 7 1/4"



ZEUS PAG. 67-70
DESIGN VINCENT VAN DUYSSEN.

FINITURE: WENGÉ E NOCE C.

DIMENSIONI MM:
1200 x 1200 H 355
1590 x 1590 H 355

FINISHING: WENGE AND WALNUT C.

DIMENSIONS IN:
47 1/4" x 47 1/4" H 14"
62 5/8" x 62 5/8" H 14"



YARD PAG. 4-6-92-95-127-132-161
DESIGN PAOLO PIVA.

STRUTTURA E PIANO IN ESSENZA,
FINITURA WENGÉ E NOCE C.
STRUTTURA IN METALLO
CROMATO, FINITURE PIANO:
LACCATO OPACO COLORI,
LACCATO LUCIDO COLORI, WENGÉ,
NOCE C. E CUIOIO.

DIMENSIONI MM:
485 x 485 H 485
Ø 485 H 485
1200 x 1200 H 295
Ø 1200 H 295

STRUCTURE AND TOP IN WOOD,
FINISHING WENGE AND WALNUT C.
STRUCTURE IN CHROMED METAL,
TOP FINISHING: MAT LACQUERED
COLOURS, GLOSSY LACQUERED
COLOURS, WENGE, WALNUT C.
AND SADDLE HIDE.

DIMENSIONS IN:
19" x 19" H 19"
Ø 19" H 19"
47 1/4" x 47 1/4" H 11 5/8"
Ø 47 1/4" H 11 5/8"

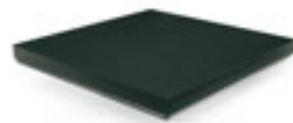

SHANGAI
DESIGN CARLO COLOMBO.

FINITURE: LACCATO OPACO
COLORI, LACCATO LUCIDO COLORI
E WENGÉ.
BASE IN ALLUMINIO BRILL.

DIMENSIONI MM:
1000 x 1000 H 110

FINISHING: MAT LACQUERED
COLOURS, GLOSSY LACQUERED
COLOURS AND WENGE.
BASE IN ALUMINIUM BRILL.

DIMENSIONS IN:
39 3/8" x 39 3/8" H 4 5/16"



TRIDENTE
DESIGN EMMANUEL GALLINA.

FINITURE: LACCATO OPACO
COLORI, WENGÉ E NOCE C.

DIMENSIONI MM:
450 x 370 H 285
520 x 420 H 480
670 x 550 H 423
1560 x 920 H 330

FINISHING: MAT LACQUERED
COLOURS, WENGE AND WALNUT C.

DIMENSIONS IN:
17 3/4" x 14 9/16" H 11 1/4"
20 1/2" x 16 9/16" H 18 7/8"
26 3/8" x 21 3/4" H 16 5/8"
61 7/16" x 36 1/4" H 13"



TREVI
DESIGN ROBERTO BARBIERI.

FINITURE: PIANO LACCATO OPACO
COLORI E IN VERSIONE
ANTIGRAFFIO NEI COLORI
BIANCO 01, CANAPA 35
E GRAFITE 04;
GAMBE IN ALLUMINIO BRILL,
LACCATO OPACO COLORI
E IN VERSIONE ANTIGRAFFIO.

DIMENSIONI MM:
900 x 900 H 236
1250 x 1250 H 236
1400 x 800 H 236
1800 x 900 H 236

FINISHING: TOP IN MAT
LACQUERED COLOURS AND IN
ANTISCRATCH VERSION IN
COLOURS WHITE 01, CANAPA 35
AND GRAFITE 04;
LEGS IN ALUMINIUM BRILL,
MAT LACQUERED COLOURS
AND IN ANTISCRATCH VERSION.

DIMENSIONS IN:
35 7/16" x 35 7/16" H 9 5/16"
49 3/16" x 49 3/16" H 9 5/16"
55 1/8" x 31 1/2" H 9 5/16"
70 7/8" x 35 7/16" H 9 5/16"



DOMINO
DESIGN CARLO COLOMBO.

FINITURE: LACCATO OPACO
COLORI E PVC LUCIDO BIANCO O
NERO; STRUTTURA IN METALLO
CROMATO.

DIMENSIONI MM:
Ø 997 H 320
Ø 485 H 485

FINISHING: MAT LACQUERED
COLOURS AND WHITE AND BLACK
GLOSSY PVC; STRUCTURE IN
CHROMED METAL.

DIMENSIONS IN:
Ø 39 1/4" H 12 1/2"
Ø 19" H 19"



VULCANO PAG. 41-42-103-104-107
DESIGN PAOLA NAVONE.

FINITURE: LACCATO OPACO
COLORI E LACCATO LUCIDO
COLORI.

DIMENSIONI MM:
600 x 400 H 570

FINISHING: MAT LACQUERED
COLOURS AND GLOSSY
LACQUERED COLOURS.

DIMENSIONS IN:
23 1/2" x 15 3/4" H 22 1/2"

DAMA
DESIGN CR&S POLIFORM.

FINITURE: NOCE C. E CEDRO.

DIMENSIONI MM:
Ø 340 H 450

FINISHING: WALNUT C. AND CEDAR.

DIMENSIONS IN:
Ø 13 3/8" H 17 11/16"

SENZAFINE UN SISTEMA ARMADI E UNA CABINA ARMADIO PROGETTATI CON UNA MODULARITÀ EVOLUTA, IN GRADO DI INSERIRSI IN OGNI SPAZIO. LA CABINA ARMADIO È CARATTERIZZATA DAI FIANCHI DI SPESSORE MM 35, CHE NE SOTTOLINEANO LA SOLIDITÀ FORMALE E IL RIGORE GEOMETRICO. DALLE ANTE PIÙ SEMPLICI E MINIMALI A QUELLE DALLA CARATTERIZZAZIONE ESTETICA PIÙ MARCATA, CON BORDI O TELAI. TRE APERTURE, BATTENTE, LIBRO E SCORREVOLE; UN'ATTREZZATURA INTERNA COMPLETA, PENSATA PER CONSENTIRE DI IMMAGINARE UN ORDINE SEMPRE PIÙ INDIVIDUALE.

FINITURE LA STRUTTURA E L'ATTREZZATURA DEL SISTEMA SENZAFINE SONO DISPONIBILI IN MELAMINA NEI COLORI: BIANCO TXT, CORDA TXT, ROVERE, WENGÉ E NOCE C. LAVABILE, DI FACILE MANUTENZIONE, RESISTENTE ALL'UMIDITÀ E AI GRAFFI: L'IMPIANTO STRUTTURALE DI OGNI ARMADIO SENZAFINE È PENSATO PER GARANTIRE SOLIDITÀ E COMPLETA AFFIDABILITÀ NEL TEMPO.

SENZAFINE A WARDROBES SYSTEM AND A WALK IN CLOSET WITH A MODERN MODULARITY, ADAPTABLE TO ANY SPACE. THE WALK IN CLOSET IS CHARACTERIZED BY VERTICAL PANELS OF 1 1/2" WHICH UNDERLINE THE SOLIDITY OF SHAPES AND THE GEOMETRY. FROM THE MORE SYMPLE AND MINIMAL DOORS TO THE ONE CHARACTERISED BY MORE PARTICULAR AESTHETIC, WITH EDGES OR FRAMES. THREE OPENINGS: LEAF, FOLDING AND SLIDING DOOR. THE COMPLETE INSIDE EQUIPMENT HAS BEEN DESIGNED TO PERSONALIZE THE SPACE ORGANISATION AS INDIVIDUALLY AS POSSIBLE.

FINISHING THE STRUCTURE AND THE EQUIPMENT OF SENZAFINE SYSTEM ARE AVAILABLE IN THE FOLLOWING COLOURS OF MELAMINE: WHITE TXT, CORDA TXT, OAK, WENGE AND WALNUT C. CAN BE EASILY CLEANED AND MAINTAINED, IT IS RESISTANT TO HUMIDITY AND TO SCRATCHES: THE STRUCTURE OF EACH SENZAFINE WARDROBE IS CONCEIVED TO GRANT SOLIDITY AND RELIABILITY FOR LONG TIME.

THE STRUCTURE AND THE EQUIPMENT OF SENZAFINE SYSTEM ARE AVAILABLE IN THE FOLLOWING COLOURS OF MELAMINE: WHITE TXT, CORDA TXT, OAK, WENGE AND WALNUT C.

SENZAFINE CABINA ARMADIO/WALK-IN CLOSET PAG. 24-28-30

	402 15 13/16"	483 19"	644 25 1/4"	805 31 11/16"	966 38"	1288 50 3/4"	1500 59 1/16"	
2910								114 1/2"
2590								102"
2430								95 3/4"
2270								89 1/4"
1950								76 3/4"
1598								63"
1278								50 1/4"
958								37 3/4"
638								25"
318								12 1/2"
BATTENTE-LIBRO/LEAF-FOLDING	614							24 1/8"
SCORREVOLE/SLIDING	652							25 5/8"

ARMADI SENZAFINE
PER OTTENERE LA LARGHEZZA TOTALE, ALLA SOMMA DELLE COLONNE AGGIUNGERE MM 25 PER IL FIANCO LATERALE.

CABINA ARMADIO SENZAFINE
PER OTTENERE LA LARGHEZZA TOTALE, ALLA SOMMA DELLE COLONNE AGGIUNGERE MM 35 PER IL FIANCO LATERALE E MM 10 PER OGNI ALTRO FIANCO PRESENTE.

SENZAFINE WARDROBE
TO OBTAIN THE TOTAL WIDTH, ADD TO THE TOTAL COLUMNS 1" FOR THE LATERAL SIDE.

SENZAFINE WALK-IN CLOSET
TO OBTAIN THE TOTAL WIDTH, ADD TO THE TOTAL COLUMNS 1 1/2" FOR THE LATERAL SIDE AND 1/2" FOR ANY OTHER VERTICAL PANEL OF THE CLOSET.

SOLUZIONI SPECIALI.
IL SISTEMA PREVEDE TAGLI A MISURA IN LARGHEZZA, ALTEZZA E PROFONDITÀ; FASCE DI TAMPONAMENTO ORIZZONTALI E VERTICALI; CAMBI DI PROFONDITÀ; COMPOSIZIONI A PONTE; PASSAGGI PORTA; ELEMENTI TERMINALI.
IL PROGRAMMA PERMETTE DI RISOLVERE AL MEGLIO LE SITUAZIONI D'ANGOLO.

SPECIAL SOLUTIONS.
THE SYSTEM PROVIDES CUTS ON MEASURE IN WIDTH, HEIGHT AND DEPTH; HORIZONTAL AND VERTICAL FILLER; CHANGES IN DEPTH; BRIDGE WARDROBES; DOOR PASSAGES; END WARDROBES.
THE SYSTEM ALLOWS TO SOLVE THE CORNER SITUATIONS IN THE BEST WAY.



NEW ENTRY PAG. 181
DESIGN CR&S POLIFORM.

APERTURE: BATTENTE, LIBRO, SCORREVOLE E CASSETTI.
FINITURE ANTA: LACCATO OPACO COLORI, LACCATO LUCIDO COLORI, WENGÉ, NOCE C. E ROVERE LACCATO OPACO COLORI A PORO APERTO.
FINITURA WENGÉ, NOCE C. E ROVERE LACCATO OPACO COLORI A PORO APERTO SOLO NELLE ALTEZZE MM 1950-2270-2430-2590.

OPENINGS: LEAF, FOLDING AND SLIDING DOOR AND DRAWERS.
DOOR FINISHING: MAT LACQUERED COLOURS, GLOSSY LACQUERED COLOURS, WENGE, WALNUT C AND COLOURS MAT LACQUERED OAK IN OPEN PORE.
WENGE, WALNUT C AND COLOURS MAT LACQUERED OAK IN OPEN PORE FINISHING ONLY FOR THE HEIGHT: 76 3/4" - 89 1/4" - 95 3/4" 102".



CLUB
DESIGN CR&S POLIFORM.

APERTURE: BATTENTE, LIBRO, SCORREVOLE E CASSETTI.
FINITURE ANTA: MELAMINA NEI COLORI BIANCO 01, PANNA 42, CANAPA 35, BORDO IN TINTA O WENGÉ. MELAMINA WENGÉ BORDO IN TINTA.

OPENINGS: LEAF, FOLDING AND SLIDING DOOR AND DRAWERS.
DOOR FINISHING: MELAMINE IN THE COLOURS BIANCO 01, PANNA 42, CANAPA 35, EDGE IN SAME COLOUR OR IN WENGE. MELAMINE WENGE EDGE SAME COLOUR.



NEW BASIC
DESIGN CR&S POLIFORM.

APERTURA: BATTENTE.
FINITURE ANTA: LACCATO OPACO NEI COLORI BIANCO 01, PANNA 42, CANAPA 35 E METACRILATO BIANCO LUCIDO.
DISPONIBILE SOLO NELLA ALTEZZA MM 2590.

OPENING: LEAF DOOR.
DOOR FINISHING: MAT LACQUERED IN THE COLOURS BIANCO 01, PANNA 42, CANAPA 35 AND WHITE GLOSSY METHACRYLATE.
AVAILABLE ONLY HEIGHT: 102".



GRAFFITI
DESIGN CARLO COLOMBO.

APERTURE: BATTENTE, LIBRO E SCORREVOLE.
FINITURE ANTA: MELAMINA GRAFFITI NEI COLORI BIANCO 01, PANNA 42, CANAPA 35.

OPENINGS: LEAF, FOLDING AND SLIDING DOOR.
DOOR FINISHING: GRAFFITI MELAMINE IN THE COLOURS BIANCO 01, PANNA 42, CANAPA 35.



SURF
DESIGN CARLO COLOMBO.

APERTURE: BATTENTE E SCORREVOLE.
FINITURE ANTA: MELAMINA SURF BIANCA E LACCATO OPACO COLORI.

OPENINGS: LEAF DOOR SLIDING DOOR.
DOOR FINISHING: SURF WHITE MELAMINE AND MAT LACQUERED COLOURS.



SELF
DESIGN CR&S POLIFORM.

APERTURA SCORREVOLE.
FINITURE ANTA: LACCATO OPACO COLORI, LACCATO LUCIDO COLORI, SPECCHIO BIANCO, FUMÈ E BRONZATO. FINITURE PROFILO: ALLUMINIO BRILL E ALLUMINIO BRONZATO.

OPENING: SLIDING DOOR.
DOOR FINISHING: MAT LACQUERED COLOURS, GLOSSY LACQUERED COLOURS, WHITE, SMOKED AND BRONZED MIRROR. FRAME FINISHING: BRILL ALUMINIUM AND BRONZED ALUMINIUM.



HAVANA
DESIGN DELL'ORTO-CATTANEO.

APERTURE: BATTENTE E SCORREVOLE.
FINITURE ANTA: LACCATO OPACO COLORI, WENGÉ, SPECCHIO FUMÈ.
FINITURE PROFILO: LACCATO OPACO COLORI, WENGÉ E NOCE C.

OPENINGS: LEAF DOOR SLIDING DOOR.
DOOR FINISHING: MAT LACQUERED COLOURS, WENGE AND FUMÈ MIRROR. FRAME FINISHING: MAT LACQUERED COLOURS, WENGE AND WALNUT C.



SYDNEY PAG. 23-24-27-28-61-63
DESIGN CR&S POLIFORM.

APERTURE: BATTENTE E SCORREVOLE.
FINITURE ANTA: VETRO RIFLETTENTE BLU, 8 COLORI VETRO LUCIDO E 8 COLORI VETRO SATINATO, SPECCHIO BIANCO. FINITURE TELAIO: LACCATO OPACO COLORI, ALLUMINIO E ALLUMINIO ANODIZZATO NERO.

OPENINGS: LEAF AND SLIDING DOOR.
DOOR FINISHING: REFLECTING GLASS BLU, 8 COLOURS GLOSSY GLASS AND 8 COLOURS MAT GLASS, WHITE MIRROR. FRAME FINISHING: MAT LACQUERED COLOURS, ALUMINIUM AND ALUMINIUM ANODIZED BLACK.



ATLANTA
DESIGN CR&S POLIFORM.

APERTURE: BATTENTE E SCORREVOLE.
FINITURE ANTA: LACCATO OPACO COLORI E ROVERE LACCATO OPACO COLORI A PORO APERTO. FINITURE PROFILO: LACCATO OPACO COLORI, ROVERE LACCATO OPACO COLORI A PORO APERTO, WENGÉ E NOCE C.

OPENINGS: LEAF AND SLIDING DOOR.
DOOR FINISHING: MAT LACQUERED COLOURS AND COLOURS MAT LACQUERED OAK IN OPEN PORE. FRAME FINISHING: MAT LACQUERED COLOURS, COLOURS MAT LACQUERED OAK IN OPEN PORE, WENGE AND WALNUT C.



MADISON
DESIGN CARLO COLOMBO.

APERTURA BATTENTE.
FINITURE ANTA: ROVERE LACCATO OPACO COLORI A PORO APERTO, WENGÉ E NOCE C.

OPENING: LEAF DOOR.
DOOR FINISHING: COLOURS MAT LACQUERED OAK IN OPEN PORE, WENGE AND WALNUT C.



BANGKOK PAG. 91-92
DESIGN OPERADESIGN.

APERTURA SCORREVOLE.
FINITURE ANTA: RIVESTITA IN CUOIO, LACCATO OPACO COLORI E LACCATO LUCIDO COLORI.

OPENING: SLIDING DOOR.
DOOR FINISHING: UPHOLSTERED WITH HIDE LEATHER, MAT LACQUERED COLOURS AND GLOSSY LACQUERED COLOURS.



ONE PAG. 121-127
DESIGN CARLO COLOMBO.

APERTURA SCORREVOLE.
ONE 2: ANTA SUDDIVISA IN 2 PANNELLI O VETRI.
ONE 4: ANTA SUDDIVISA IN 4 PANNELLI O VETRI.
FINITURE ANTA: LACCATO OPACO COLORI, VETRO RIFLETTENTE SATINATO PERLA, VETRO RIFLETTENTE BLU, 8 COLORI VETRO LUCIDO E 8 COLORI VETRO SATINATO.
FINITURE PROFILO: ALLUMINIO ANODIZZATO NERO E NATURALE, LACCATO OPACO COLORI, NOCE C., ROVERE E ROVERE TINTO WENGÉ.

OPENING: SLIDING DOOR.
ONE 2: DOOR DIVIDED IN 2 PANELS OR GLASSES.
ONE 4: DOOR DIVIDED IN 4 PANELS OR GLASSES.
DOOR FINISHING: MAT LACQUERED COLOURS, PERLA MAT REFLECTING GLASS, REFLECTING GLASS BLU, 8 COLOURS GLOSSY GLASS AND 8 COLOURS MAT GLASS.
FRAME FINISHING: BLACK AND NATURAL ANODIZED ALUMINIUM, MAT LACQUERED COLOURS, WALNUT C., OAK AND OAK PAINTED WENGE.

UBIK PAG. 99-153-154-179-181 DESIGN CR&S POLIFORM.

UBIK È UN SISTEMA DI PANNELLI CHE RIVESTONO LE PARETI, COMPLETATI ED ATTREZZATI DA UN'AMPIA VARIETÀ DI COMPONENTI: RIPIANI, BARRE APPENDIABILI, PORTAPANTALONI, CONTENITORI A TERRA, SU RUOTE E SOSPESI. LA POSSIBILITÀ DI POSIZIONARE LE ATTREZZATURE ALL'ALTEZZA DESIDERATA CONFERMA LA FLESSIBILITÀ DEL SISTEMA.

FINITURE I PANNELLI E LE ATTREZZATURE DEL SISTEMA UBIK SONO DISPONIBILI IN MELAMINA IN 4 FINITURE: BIANCO TXT, ROVERE, WENGÈ E NOCE C. LAVABILE, DI FACILE MANUTENZIONE, RESISTENTE ALL'UMIDITÀ E AI GRAFFI: UNA FINITURA PENSATA PER GARANTIRE SOLIDITÀ E COMPLETA AFFIDABILITÀ NEL TEMPO. I PANNELLI SONO DISPONIBILI ANCHE IN 8 COLORI PER IL VETRO LUCIDO E IN SPECCHIO BIANCO E FUMÉ.

UBIK SYSTEM CONSISTS OF WALL PANELS, COMPLETED AND EQUIPPED WITH A WIDE RANGE OF ACCESSORIES: SHELVES, CLOTHES RACKS, PULL OUT TROUSER HOLDER, FLOOR CONTAINERS, HANGING CABINETS AND CHEST OF DRAWERS ON CASTORS. THE POSSIBILITY OF A FREE POSITIONING IN HEIGHT OF THE EQUIPMENT CONFIRMS THE FLEXIBILITY OF THE SYSTEM.

FINISHING WALL PANELS AND EQUIPMENTS OF UBIK ARE AVAILABLE IN 4 DIFFERENT MELAMINES: WHITE TXT, OAK, WENGE AND WALNUT C. WASHABLE, EASY TO CARE, HUMIDITY AND SCRATCHES RESISTANT: A SOLID, RELIABLE AND LASTING FINISHING. WALL PANELS ARE ALSO AVAILABLE IN THE 8 GLOSSY GLASS COLOURS AND IN WHITE AND FUME' MIRROR.

LARGHEZZE PANNELLI /
PANELS WIDTHS

458 MM
18"

619 MM
24 1/4"

941 MM
37"

1005 x 1005 MM
39 1/2" x 39 1/2"

ALTEZZE PANNELLI /
PANELS HEIGHTS

2910

2590

2430

114 1/2"

102"

95 3/4"

I PANNELLI SONO DISPONIBILI IN 3 ALTEZZE E 3 LARGHEZZE; SPESSORE MM 60. PER OTTENERE LA LARGHEZZA TOTALE, ALLA SOMMA DEI PANNELLI AGGIUNGERE MM 72 (PROFILI TERMINALI) E MM 4 TRA OGNI PANNELLO.

THE PANELS ARE AVAILABLE IN 3 HEIGHTS AND 3 WIDTHS; THICKNESS 2 1/4". TO OBTAIN THE TOTAL WIDTH, ADD TO THE TOTAL PANELS 2 3/4" (END FRAMES) AND 1/4" BETWEEN EACH PANEL.

PROFONDITÀ BASAMENTI
E RIPIANI / BASEMENTS AND
SHELVES DEPTHS

605

23 7/8"

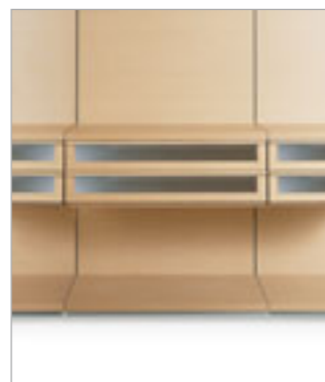
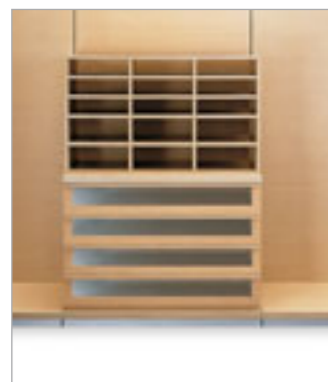

I CONTENITORI DEL PROGETTO UBIK SONO LIBERAMENTE ATTREZZABILI. LE POSSIBILITÀ PREVEDONO CASSETTI CON FRONTALE LEGNO O VETRO, VASSOI E PORTASCARPE ESTRAIBILI, A CUI SI AGGIUNGE LA CAMICIERA CON CONTENITORI RIVESTITI IN TESSUTO.

UBIK CONTAINERS CAN BE EQUIPPED AS YOU LIKE. THE POSSIBILITIES INCLUDE DRAWERS WITH WOODEN OR GLASS FRONT, TRAYS, EXTRACTABLE SHOE RACK AND SHIRTS RACK WITH CONTAINERS COVERED WITH FABRIC.

CLOSE DESIGN CARLO COLOMBO.

CLOSE È UN SISTEMA DI ANTE SCORREVOLI SU BINARIO, PROGETTATO APPOSITAMENTE PER CHIUDERE I VANI DELLE CABINE ARMADIO POLIFORM. IL BINARIO DI SCORRIMENTO PUÒ ESSERE INSTALLATO IN CORRISPONDENZA DEL VANO (IN LUCE) O ALL'ESTERNO (FUORI LUCE). E' POSSIBILE CREARE COMPOSIZIONI CON UNA, DUE, TRE O QUATTRO ANTE. LA VARIETÀ DELLE FINITURE A DISPOSIZIONE DELLE ANTE CLOSE PERMETTE DI INTERPRETARE MOLTEPLICI STILI DI ARREDAMENTO, FORMULANDO UNA GRANDE VARIETÀ DI PROPOSTE ESTETICAMENTE DIFFERENTI. DAI VETRI TRASPARENTI AGLI SPECCHI, FINO AI VETRI COLORATI: GLI SPAZI POSSONO ESSERE DEFINITI IN BASE ALLE PIÙ DIVERSE VALENZE STILISTICHE.

CLOSE IS A SYSTEM WITH SLIDING DOORS ON RAILS, PROJECTED TO CLOSE THE UNITS OF POLIFORM WARDROBES. THE RAIL CAN BE INSTALLED MATCHING THE EDGE OF THE UNITS OR OUTSIDE THE UNITS COMPOSITIONS. IT IS POSSIBLE TO CREATE THE COMPOSITIONS WITH ONE, TWO, THREE OR FOUR DOORS. THE VARIETY OF AVAILABLE FINISHES FOR CLOSE SLIDING DOORS ALLOWS YOU TO INTERPRET DIFFERENT STYLES. FROM TRANSPARENT GLASS TO MIRROR GLASS TO COLOUR GLASS: THE ENVIROMENTS CAN BE DEFINED IN FUNCTION OF THE DIFFERENT STYLES.

LARGHEZZE PORTE /
DOORS WIDTHS

DA 600 MM
A 900 MM
FROM 23 5/8"
TO 35 1/2"

DA 901 MM
A 1100 MM
FROM 35 1/2"
TO 43 5/16"

DA 1101 MM
A 1200 MM
FROM 43 3/8"
TO 47 1/4"

ALTEZZE PORTE /
DOORS HEIGHTS

A MISURA
FINO A 3000 MM
BINARIO
COMPRESO

ON MEASURE
UP TO 118 1/8"
RAIL INCLUDED

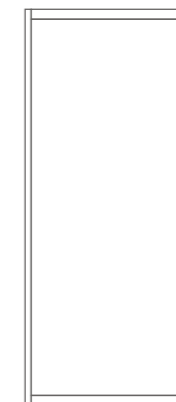
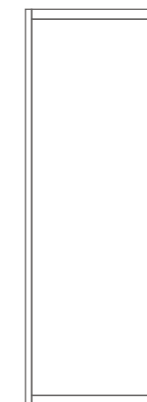

FINITURE VETRO SPESSORE 6 MM TRASPARENTE, ACIDATO, FUMÉ E RIFLETTENTE SATINATO PERLA. VETRO SPESSORE 3+3 MM SEMITRASPARENTE BIANCO, LUCIDO NEI COLORI BIANCO EXTRACHIARO, PERLA E NERO.

FINISHING TRANSPARENT, FROSTED, FUME' AND MAT PERLA REFLECTING GLASS 6 MM THICK. WHITE SEMI-TRANSPARENT, GLOSSY EXTRALIGHT WHITE, PERLA AND BLACK GLASS 3+3 MM THICK.



ONDA PAG. 31-32-34
DESIGN PAOLO PIVA.

FINITURE: GIROLETTO
E TESTATA IMBOTTITI CON
RIVESTIMENTO TESATO IN PELLE.
PIEDINI CROMATI.

FINISHING: UPHOLSTERED
FRAME AND HEADBOARD
COVERED IN LEATHER.
CHROMED FEET.

PREDISPOSTO PER MATERASSI
DIMENSIONI MM:
1600 x 2000
1800 x 2000

FOR MATTRESSES
DIMENSIONS IN:
63" x 78 3/4"
70 3/4" x 78 3/4"



TEO LEGNO
DESIGN PAOLO PIVA.

FINITURE: LACCATO
OPACO COLORI, WENGÉ
E NOCE C.

WOODEN BED.FINISHING: MAT
LACQUERED COLOURS, WENGE
AND WALNUT C.

PREDISPOSTO PER MATERASSI
DIMENSIONI MM:
1600 x 2000
1600 x 2100
1800 x 2000
1800 x 2100

FOR MATTRESSES
DIMENSIONS IN:
63" x 78 3/4"
63" x 82 3/4"
70 3/4" x 78 3/4"
70 3/4" x 82 3/4"



ASTRO PAG. 148-151
DESIGN ROBERTO LAZZERONI.

FINITURE: LACCATO OPACO
COLORI, WENGÉ E NOCE C.
TESTATA CON RIVESTIMENTO
SFODERABILE IN
TESSUTO E PELLE O IN
LEGNO FINITURE WENGÉ
E NOCE C.

FINISHING: MAT LACQUERED
COLOURS, WENGE AND
WALNUT C.
HEADBOARD COVERED
WITH REMOVABLE FABRIC
AND LEATHER OR IN WOODEN
FINISHING WENGE AND WALNUT C.

PREDISPOSTO PER MATERASSI
DIMENSIONI MM:
1600 x 2000
1600 x 2100
1800 x 2000
1800 x 2100

FOR MATTRESSES
DIMENSIONS IN:
63" x 78 3/4"
63" x 82 3/4"
70 3/4" x 78 3/4"
70 3/4" x 82 3/4"



MEMO
DESIGN CARLO COLOMBO.

FINITURE: WENGÉ E NOCE C.

FINISHING: WENGE AND WALNUT C.

PREDISPOSTO PER MATERASSI
DIMENSIONI MM:
1600 x 2000
1600 x 2100
1800 x 2000
1800 x 2100

FOR MATTRESSES
DIMENSIONS IN:
63" x 78 3/4"
63" x 82 3/4"
70 3/4" x 78 3/4"
70 3/4" x 82 3/4"



TEO RIVESTITO PAG. 177-179
DESIGN PAOLO PIVA.

FINITURE: TESTATA E TURCA CON
RIVESTIMENTO SFODERABILE IN
TESSUTO E NON SFODERABILE IN
PELLE.

FINISHING: HEADBOARD AND BED
FRAME COVERED IN REMOVABLE
FABRIC, NON- REMOVABLE IN
LEATHER.

PREDISPOSTO PER MATERASSI
DIMENSIONI MM:
1600 x 2000
1600 x 2100
1800 x 2000
1800 x 2100

FOR MATTRESSES
DIMENSIONS IN:
63" x 78 3/4"
63" x 82 3/4"
70 3/4" x 78 3/4"
70 3/4" x 82 3/4"



TEO CUOIO
DESIGN PAOLO PIVA.

FINITURE: TESTATA E TURCA CON
RIVESTIMENTO IN CUOIO.

FINISHING: HEADBOARD AND BED
FRAME COVERED IN HIDE.

PREDISPOSTO PER MATERASSI
DIMENSIONI MM:
1600 x 2000
1600 x 2100
1800 x 2000
1800 x 2100

FOR MATTRESSES
DIMENSIONS IN:
63" x 78 3/4"
63" x 82 3/4"
70 3/4" x 78 3/4"
70 3/4" x 82 3/4"



MEMO DUE
DESIGN CARLO COLOMBO.

FINITURE: LACCATO OPACO
COLORI.

FINISHING: MAT LACQUERED
COLOURS.

PREDISPOSTO PER MATERASSI
DIMENSIONI MM:
1600 x 2000
1600 x 2100
1800 x 2000
1800 x 2100

FOR MATTRESSES
DIMENSIONS IN:
63" x 78 3/4"
63" x 82 3/4"
70 3/4" x 78 3/4"
70 3/4" x 82 3/4"



MEMO DUE PELLE
DESIGN CARLO COLOMBO.

FINITURE: COMPLETAMENTE
RIVESTITO IN PELLE.

FINISHING: COMPLETELY COVERED
IN LEATHER.

PREDISPOSTO PER MATERASSI
DIMENSIONI MM:
1600 x 2000
1600 x 2100
1800 x 2000
1800 x 2100

FOR MATTRESSES
DIMENSIONS IN:
63" x 78 3/4"
63" x 82 3/4"
70 3/4" x 78 3/4"
70 3/4" x 82 3/4"



ARCA PAG. 92-95
DESIGN PAOLO PIVA.

FINITURE: LACCATO OPACO COLORI E WENGÉ.
TESTATA ALTA O BASSA CON RIVESTIMENTO SFODERABILE IN TESSUTO E PELLE;
TESTATA BASSA DISPONIBILE ANCHE IN LEGNO.
TURCA IN LEGNO O CON RIVESTIMENTO SFODERABILE IN TESSUTO. POSSIBILITÀ BASE LETTO CONTENITORE CON RETE RIBALTABILE.
QUEEN SIZE E KING SIZE DISPONIBILI SOLO NELLA FINITURA WENGÉ.

PREDISPOSTO PER MATERASSI
DIMENSIONI MM:
1600 x 2000
1600 x 2100
1800 x 2000
1800 x 2100
2000 x 2000
2000 x 2100
CON BASE CONTENITORE
PREDISPOSTO PER MATERASSI
DIMENSIONI MM:
1600 x 2000
1800 x 2000



FINISHING: MAT LACQUERED COLOURS AND WENGÉ.
HIGH OR LOW HEADBOARD COVERED WITH REMOVABLE FABRIC AND LEATHER,
LOW HEADBOARD AVAILABLE ALSO IN WOOD.
WOODEN BED FRAME CAN BE COVERED IN REMOVABLE FABRIC.
BED FRAME WITH CONTAINER AVAILABLE WITH TIP-UP BEDSTEAD.
QUEEN SIZE AND KING SIZE AVAILABLE ONLY IN WENGÉ FINISHING.

FOR MATTRESSES
DIMENSIONS IN:
63" x 78 3/4"
63" x 82 3/4"
70 3/4" x 78 3/4"
70 3/4" x 82 3/4"
78 3/4" x 78 3/4"
78 3/4" x 82 3/4"
BED FRAME WITH CONTAINER
FOR MATTRESSES
DIMENSIONS IN:
63" x 78 3/4"
70 3/4" x 78 3/4"



ALA
DESIGN PAOLO PIVA.

FINITURE: LACCATO OPACO COLORI E WENGÉ. TESTATA CON RIVESTIMENTO SFODERABILE IN TESSUTO E PELLE O IN LEGNO
TRAFORATA FINITURA WENGÉ.
POSSIBILITÀ DI BASE LETTO CONTENITORE CON RETE RIBALTABILE.

PREDISPOSTO PER MATERASSI
DIMENSIONI MM:
1600 x 2000
1600 x 2100
1800 x 2000
1800 x 2100
CON BASE CONTENITORE
PREDISPOSTO PER MATERASSI
DIMENSIONI MM:
1600 x 2000
1800 x 2000



FINISHING: MAT LACQUERED COLOURS AND WENGÉ.
HEADBOARD COVERED WITH REMOVABLE FABRIC AND LEATHER OR IN FRETWORK WOODEN FINISHING WENGÉ.
BED FRAME WITH CONTAINER AVAILABLE WITH TIP-UP BEDSTEAD.

FOR MATTRESSES
DIMENSIONS IN:
63" x 78 3/4"
63" x 82 3/4"
70 3/4" x 78 3/4"
70 3/4" x 82 3/4"
BED FRAME WITH CONTAINER
FOR MATTRESSES
DIMENSIONS IN:
63" x 78 3/4"
70 3/4" x 78 3/4"



VICTOR
DESIGN MARIO MAZZER.

FINITURE: TESTATA IMBOTTITA CON RIVESTIMENTO SFODERABILE IN TESSUTO E PELLE.
TURCA IN LEGNO FINITURA WENGÉ O CON RIVESTIMENTO SFODERABILE IN TESSUTO E PELLE. POSSIBILITÀ DI BASE LETTO CONTENITORE CON RETE RIBALTABILE.
RETROLETTO WENGÉ.

PREDISPOSTO PER MATERASSI
DIMENSIONI MM:
1600 x 2000
1800 x 2000

FINISHING: PADDED HEADBOARD WITH REMOVABLE COVER IN FABRIC AND LEATHER.
WOODEN BED FRAME IN WENGÉ, OR WITH REMOVABLE COVER IN FABRIC AND LEATHER.
BED FRAME WITH CONTAINER AVAILABLE WITH TIP-UP BEDSTEAD. BENCHES BEHIND THE BED IN WENGÉ.

FOR MATTRESSES
DIMENSIONS IN:
63" x 78 3/4"
70 3/4" x 78 3/4"



MOON
DESIGN CARLO COLOMBO.

FINITURE: TESTATA E TURCA IMBOTTITE CON RIVESTIMENTO SFODERABILE IN TESSUTO; RIVESTIMENTO NON SFODERABILE IN PELLE.
POSSIBILITÀ DI BASE LETTO CONTENITORE CON RETE RIBALTABILE.

PREDISPOSTO PER MATERASSI
DIMENSIONI MM:
1600 x 2000
1700 x 2000
1800 x 2000
CON BASE CONTENITORE
PREDISPOSTO PER MATERASSI
DIMENSIONI MM:
1600 x 2000
1700 x 2000
1800 x 2000

FINISHING: PADDED HEADBOARD AND BED FRAME WITH REMOVABLE COVER IN FABRIC; LEATHER COVERS ARE NOT REMOVABLE.
BED FRAME WITH CONTAINER AVAILABLE WITH TIP-UP BEDSTEAD.

FOR MATTRESSES
DIMENSIONS IN:
63" x 78 3/4"
66 15/16" x 78 3/4"
70 3/4" x 78 3/4"
BED FRAME WITH CONTAINER
FOR MATTRESSES
DIMENSIONS IN:
63" x 78 3/4"
66 15/16" x 78 3/4"
70 3/4" x 78 3/4"



DREAM
DESIGN MARCEL WANDERS.

FINITURE: TURCA, TESTATA E PANNELLATURA A MURO IMBOTTITE CON RIVESTIMENTO SFODERABILE IN TESSUTO E NON SFODERABILE IN PELLE. IL SISTEMA DI PANNELLI PUÒ ESSERE UTILIZZATO PER COMPORRE, OLTRE ALLA TESTATA DEL LETTO, ANCHE UNA BOISERIE, COMPLETATA DA MENSOLE NELLE FINITURE LACCATO OPACO COLORI, LACCATO LUCIDO COLORI E WENGÉ O DA SPECCHI A PARETE.

PREDISPOSTO PER MATERASSI
DIMENSIONI MM:
1600 x 2000
1600 x 2100
1800 x 2000
1800 x 2100



FINISHING: BED FRAME, HEADBOARD AND WALL PANNELLING UPHOLSTERED WITH REMOVABLE COVER IN FABRIC. NON-REMOVABLE IN LEATHER. THE PANELS SYSTEM MAY BE USED ALSO TO COMPOSE A WALL PANELLING COMPLETED WITH SHELVES IN MAT LACQUERED COLOURS, GLOSSY LACQUERED COLOURS AND WENGE OR WITH WALL MIRRORS.

FOR MATTRESSES
DIMENSIONS IN:
63" x 78 3/4"
63" x 82 3/4"
70 3/4" x 78 3/4"
70 3/4" x 82 3/4"



ANDO
DESIGN PAOLO PIVA.

FINITURE: LACCATO OPACO COLORI, WENGÉ E ROVERE.

FINISHING: MAT LACQUERED COLOURS, WENGE AND OAK.

PREDISPOSTO PER MATERASSI
DIMENSIONI MM:
900 x 2000
1600 x 2000
1600 x 2100
1800 x 2000
1800 x 2100

FOR MATTRESSES
DIMENSIONS IN:
35 1/2" x 78 3/4"
63" x 78 3/4"
63" x 82 3/4"
70 3/4" x 78 3/4"
70 3/4" x 82 3/4"



ZOE PAG. 59-61
DESIGN PAOLO PIVA.

FINITURE: LACCATO OPACO COLORI, LACCATO LUCIDO COLORI, WENGÉ E NOCE C. TESTATA CON RIVESTIMENTO SFODERABILE IN TESSUTO E PELLE. QUEEN SIZE E KING SIZE DISPONIBILI SOLO NELLA FINITURA WENGÉ.

FINISHING: MAT LACQUERED COLOURS, GLOSSY LACQUERED COLOURS, WENGE AND WALNUT C. HEADBOARD COVERED WITH REMOVABLE FABRIC AND LEATHER. QUEEN SIZE AND KING SIZE AVAILABLE ONLY IN WENGE FINISHING.

PREDISPOSTO PER MATERASSI
DIMENSIONI MM:
1600 x 2000
1600 x 2100
1800 x 2000
1800 x 2100

FOR MATTRESSES
DIMENSIONS IN:
63" x 78 3/4"
63" x 82 3/4"
70 3/4" x 78 3/4"
70 3/4" x 82 3/4"



DREAM DUE
DESIGN MARCEL WANDERS.

FINITURE: TURCA, TESTATA IMBOTTITE CON RIVESTIMENTO SFODERABILE IN TESSUTO E PELLE.

PREDISPOSTO PER MATERASSI
DIMENSIONI MM:
1600 x 2000
1600 x 2100
1800 x 2000
1800 x 2100

FINISHING: BED FRAME, HEADBOARD UPHOLSTERED WITH REMOVABLE COVER IN FABRIC AND LEATHER.

FOR MATTRESSES
DIMENSIONS IN:
63" x 78 3/4"
63" x 82 3/4"
70 3/4" x 78 3/4"
70 3/4" x 82 3/4"



MOBY PAG. 123-127
DESIGN STUDIO KAIROS.

FINITURE: TESTATA IMBOTTITA E TURCA LEGNO CON RIVESTIMENTO SFODERABILE IN TESSUTO; RIVESTIMENTO NON SFODERABILE IN PELLE.

PREDISPOSTO PER MATERASSI
DIMENSIONI MM:
1600 x 2000
1600 x 2100
1800 x 2000
1800 x 2100

FINISHING: PADDED HEADBOARD AND WOODEN BED FRAME WITH REMOVABLE COVER IN FABRIC; LEATHER COVERS ARE NOT REMOVABLE.

FOR MATTRESSES
DIMENSIONS IN:
63" x 78 3/4"
63" x 82 3/4"
70 3/4" x 78 3/4"
70 3/4" x 82 3/4"



MOBY
DESIGN STUDIO KAIROS.

FINITURE: TESTATA IMBOTTITA E TURCA LEGNO CON RIVESTIMENTO SFODERABILE IN TESSUTO; RIVESTIMENTO NON SFODERABILE IN PELLE.

PREDISPOSTO PER MATERASSI
DIMENSIONI MM:
900 x 2000

FINISHING: PADDED HEADBOARD AND WOODEN BED FRAME WITH REMOVABLE COVER IN FABRIC; LEATHER COVERS ARE NOT REMOVABLE.

FOR MATTRESSES
DIMENSIONS IN:
35 1/2" x 78 3/4"



ARCA
DESIGN PAOLO PIVA.

FINITURE: LACCATO OPACO COLORI E WENGÉ. TESTATA CON RIVESTIMENTO SFODERABILE IN TESSUTO E PELLE. TURCA IN LEGNO O CON RIVESTIMENTO SFODERABILE IN TESSUTO.

PREDISPOSTO PER MATERASSI
DIMENSIONI MM:
900 x 2000

FINISHING: MAT LACQUERED COLOURS AND WENGE. HEADBOARD COVERED WITH REMOVABLE FABRIC AND LEATHER. WOODEN BED FRAME CAN BE COVERED IN REMOVABLE FABRIC.

FOR MATTRESSES
DIMENSIONS IN:
35 1/2" x 78 3/4"



ALA PAG. 29-32-124
DESIGN PAOLO PIVA.

FINITURE: LACCATO OPACO
COLORI, WENGÉ E NOCE C.
LACCATO LUCIDO COLORI SOLO
PER CASSETTIERA DA APPOGGIO.

DIMENSIONI MM:
PANCHE
L 1360 P 560 H 266
L 1810 P 560 H 266
CASSETTIERA PER PANCHE
L 1300 P 527 H 400
COMODINO 1 CASSETTO
L 675 P 475 H 218
COMODINO 2 CASSETTI
L 450 P 475 H 403
CASSETTIERA
L 1300 P 527 H 625

FINISHING: MAT LACQUERED
COLOURS, WENGE AND WALNUT C.
GLOSSY LACQUERED COLOURS
ONLY CHEST OF DRAWERS FOR
BENCHES.

DIMENSIONS IN:
BENCHES
W 53 1/2" D 22" H 10 1/2"
W 71 1/4" D 22" H 10 1/2"
CHEST OF DRAWERS FOR BENCHES
W 51 1/4" D 20 3/4" H 15 3/4"
NIGHT TABLE 1 DRAWER
W 26 5/8" D 18 3/4" H 8 5/8"
NIGHT TABLE 2 DRAWERS
W 17 3/4" D 18 3/4" H 15 3/4"
CHEST OF DRAWERS
W 51 1/4" D 20 3/4" H 24 1/2"



DREAM PAG. 56
DESIGN MARCEL WANDERS.

FINITURE: LACCATO OPACO
COLORI, LACCATO LUCIDO
COLORI, WENGÉ E NOCE C.
COMODINO ROTONDO LACCATO
OPACO COLORI E LACCATO
LUCIDO COLORI.

DIMENSIONI MM:
COMODINI
L 687 - 952 P 475 H 394
Ø 450 H 427
CASSETTIERA
L 1300 P 526 H 625
SETTIMANALE
L 687 P 526 H 1319



FINISHING: MAT LACQUERED
COLOURS, GLOSSY LACQUERED
COLOURS, WENGE AND WALNUT C.
ROUND NIGHT TABLE MAT AND
GLOSSY LACQUERED COLOURS.

DIMENSIONS IN:
NIGHT TABLES
W 277/16" - 371/2" D 183/4" H 151/2"
Ø 17 3/4" H 16 13/16"
CHEST OF DRAWERS
W 51 1/8" D 20 11/16" H 24 5/8"
TALL CHEST OF DRAWERS
W 27 1/16" D 20 11/16" H 51 15/16"



ZOE
DESIGN PAOLO PIVA.

FINITURE: LACCATO OPACO
COLORI, LACCATO LUCIDO
COLORI, WENGÉ E NOCE C.

DIMENSIONI MM:
L 1560 P 545 H 570

FINISHING: MAT LACQUERED
COLOURS, GLOSSY LACQUERED
COLOURS, WENGE AND WALNUT C.

DIMENSIONS IN:
W 61 1/2" D 21 1/2" H 22 1/2"



VICTOR
DESIGN MARIO MAZZER.

FINITURE: LACCATO OPACO
COLORI E WENGÉ. STRUTTURA IN
METALLO CROMATO.

DIMENSIONI MM:
COMODINO
L 560 P 470 H 370
COMODINO CON CASSETTO
L 560 P 470 H 460

FINISHING: MAT LACQUERED
COLOURS AND WENGE.
STRUCTURE IN CHROMED METAL.

DIMENSIONS IN:
NIGHT TABLE
W 22" D 18 1/2" H 14 1/2"
NIGHT TABLE WITH DRAWER
W 22" D 18 1/2" H 18"



TEO PAG. 174-177
DESIGN PAOLO PIVA.

FINITURE: LACCATO OPACO
COLORI, WENGÉ E NOCE C.

DIMENSIONI MM:
COMODINO
Ø 485 H 525
CASSETTIERA
L 1235 P 560 H 677

FINISHING: MAT LACQUERED
COLOURS, WENGE AND WALNUT C.

DIMENSIONS IN:
NIGHT TABLE
Ø 19" H 20 3/4"
CHEST OF DRAWERS
W 48 1/2" D 22" H 26 5/8"



ANDO
DESIGN PAOLO PIVA.

FINITURE: LACCATO OPACO
COLORI, WENGÉ E ROVERE.

DIMENSIONI MM:
CASSETTIERA 5 CASSETTI
L 952 P 527 H 983
CASSETTIERA 6 CASSETTI
L 1560 P 527 H 691

FINISHING: MAT LACQUERED
COLOURS, WENGE AND OAK.

DIMENSIONS IN:
CHEST OF 5 DRAWERS
W 37 1/2" D 20 3/4" H 38 3/4"
CHEST OF 6 DRAWERS
W 61 1/2" D 20 3/4" H 27 1/4"



ABBINABILI
DESIGN CR&S POLIFORM.

FINITURE: LACCATO OPACO
COLORI, LACCATO LUCIDO
COLORI, WENGÉ E NOCE C.

DIMENSIONI MM:
COMODINO 1 CASSETTO
L 620 P 465 H 255
COMODINO 2 CASSETTI
L 620 P 465 H 430
CASSETTIERA 4 CASSETTI
L 1200 P 520 H 700
CASSETTIERA 8 CASSETTI
L 1600 P 520 H 700
SETTIMANALE
L 620 P 520 H 1320

FINISHING: MAT LACQUERED
COLOURS, GLOSSY LACQUERED
COLOURS, WENGE AND WALNUT C.

DIMENSIONS IN:
NIGHT TABLE 1 DRAWER
W 24 1/2" D 18 1/4" H 10"
NIGHT TABLE 2 DRAWERS
W 24 1/2" D 18 1/4" H 17"
CHEST OF 4 DRAWERS
W 47 1/4" D 20 1/2" H 27 1/2"
CHEST OF 8 DRAWERS
W 63" D 20 1/2" H 27 1/2"
TALL CHEST OF DRAWERS
W 24 1/2" D 20 1/2" H 52"



MEMO
DESIGN CARLO COLOMBO.

FINITURE: WENGÉ E NOCE C.

DIMENSIONI MM:
COMODINO
L 450 P 450 H 530
CASSETTIERA
L 1300 P 530 H 757

FINISHING: WENGE AND WALNUT C.

DIMENSIONS IN:
NIGHT TABLE
W 17 3/4" D 17 3/4" H 20 7/8"
CHEST OF DRAWERS
W 51 3/16" D 20 7/8" H 29 13/16"



ASTRO PAG. 148-151
DESIGN ROBERTO LAZZERONI.

FINITURE: LACCATO OPACO
COLORI, WENGÉ E NOCE C.

DIMENSIONI MM:
COMODINO
L 622 P 500 H 275
CASSETTIERA
L 1197 P 540 H 704

FINISHING: MAT LACQUERED
COLOURS, WENGE AND WALNUT C.

DIMENSIONS IN:
NIGHT TABLE
W 24 1/2" D 19 3/4" H 10 3/4"
CHEST OF DRAWERS
W 47 1/4" D 21 1/4" H 27 3/4"



ARCA PAG. 96
DESIGN PAOLO PIVA.

FINITURE: LACCATO OPACO COLORI
E WENGÉ. COMODINO ALTO E
BASSO CON O SENZA CASSETTO
SOTTOPIANO, STRUTTURA IN
METALLO CROMATO.

DIMENSIONI MM:
COMODINO ALTO
L 450 P 450 H 450
COMODINO BASSO
L 675 P 450 H 295
COMODINO CON CASSETTO LEGNO
L 675 P 475 H 218
CASSETTIERA
L 1300 P 527 H 625

FINISHING: MAT LACQUERED
COLOURS AND WENGE.
TALL OR SMALL NIGHT TABLE WITH
OR WITHOUT DRAWER,
STRUCTURE IN CHROMED METAL.

DIMENSIONS IN:
TALL NIGHT TABLE
W 17 3/4" D 17 3/4" H 17 3/4"
SMALL NIGHT TABLE
W 26 1/2" D 17 3/4" H 11 1/2"
NIGHT TABLE WITH WOOD DRAWER
W 26 1/2" D 18 3/4" H 8 1/2"
CHEST OF DRAWERS
W 51 1/4" D 20 3/4" H 24 1/2"

LA VARIETÀ DELLA COLLEZIONE POLIFORM SI RISPETTUA ANCHE NELLE FINITURE: 3 ESSENZE, 25 VARIANTI DI COLORE PER I LACCATI OPACO E LUCIDO. 25 VARIANTI DI COLORE PER IL ROVERE LACCATO OPACO A PORO APERTO. 8 MELAMINE: 01 BIANCO, SABBIA, 35 CANAPA, 42 PANNA, ROVERE, WENGÉ, ROVERE GRIGIO E NOCE C. 8 COLORI PER I VETRI LUCIDO E SATINATO: BIANCO, PERLA, GRAFITE, NERO, TORTORA, CANAPA, ARAGOSTA, SIENA; 2 COLORI PER I VETRI RIFLETTENTI: VERNICIATO BLU E SATINATO PERLA. VETRI: TRASPARENTE, ACIDATO, FUMÉ E SEMITRASPARENTE BIANCO. 3 SPECCHI: BIANCO, FUMÉ E BRONZATO. IL CAMPIONARIO POLIFORM PREVEDE ANCHE UNA GRANDE SCELTA DI TESSUTI, PELLI E CUOI. PER I SISTEMI POLIFORM È DISPONIBILE UN'AMPIA GAMMA DI MANIGLIE IN DIVERSE FINITURE.

THE VARIETY OF POLIFORM COLLECTION IS ALSO EVIDENT IN THE WIDE RANGE OF FINISHINGS: 3 WOODEN FINISHINGS, 25 MAT AND GLOSSY LACQUERED COLOURS. 25 COLOURS FOR THE OPEN PORE LACQUERED OAK. 8 MELAMINE FINISHINGS: 01 BIANCO, SABBIA, 35 CANAPA, 42 PANNA, OAK, WENGE, GREY OAK AND WALNUT C. 8 COLOURS FOR THE GLOSSY AND MAT CRYSTALS: BIANCO, PERLA, GRAFITE, NERO, TORTORA, CANAPA, ARAGOSTA, SIENA. 2 COLOURS FOR THE REFLECTING CRYSTALS: VARNISHED BLUE AND SATINED PERLA. CRYSTALS: TRANSPARENT, FROSTED, SMOKED AND WHITE SEMI-TRANSPARENT. 3 MIRRORS: WHITE, SMOKED AND BRONZED. POLIFORM COLLECTION INCLUDES ALSO A WIDE RANGE OF FABRICS, LEATHER AND THICK LEATHER. FOR POLIFORM SYSTEM IS ALSO AVAILABLE A BIG SELECTION OF HANDLES IN DIFFERENT FINISHES.



LACCATO OPACO E LUCIDO / MAT AND GLOSSY LACQUERED



ART DIRECTION: PAOLO MOJOLI
FOTO TECNICHE: F2 FOTOGRAFIA

1° EDIZIONE APRILE 2008
COD. 39/R1/2008

SOLUZIONI DI FINANZIAMENTO
PERSONALIZZATO PER L'ITALIA
IN COLLABORAZIONE CON 

HEADQUARTERS:
POLIFORM SPA
VIA MONTESANTO 28
22044 INVERIGO (CO) ITALY
TEL +39/0316951
FAX +39/031699444
WWW.POLIFORM.IT
INFO.POLIFORM@POLIFORM.IT

BRANCHES:
POLIFORM UK LTD
278 KINGS ROAD
SW3 5AW
LONDON UNITED KINGDOM
TEL +44/20 7368 7600
FAX +44/20 7368 7601
INFO@POLIFORMUK.COM

POLIFORM USA INC.
ARCHITECTS & DESIGNERS
BUILDING
150 EAST 58TH STREET
NEW YORK, NY 10155 USA
1-888-POLIFORM
WWW.POLIFORMUSA.COM