



# 1955-1966 THUNDERBIRD

2009-2010  
Parts & Accessories  
Catalog



OFFICIAL LICENSEE OF  
FORD MOTOR COMPANY  
TRADEMARK PARTS

**MORE THAN  
285  
NEW ITEMS!**

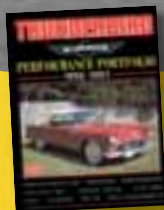

Check out our great accessories for your Bird in our  
**MACcessories Section**  
beginning on page 95



order at **800-777-0948** or  
**www.macsautoparts.com**



# LOOKING FOR SOMETHING?

**Little Bird Index: page 88-93**

**Big Bird Index: page 246-253**

**Order Forms: page 258-262**

**International Shipping Information:  
page 257**

## Make Your Bird Fly With Our Hub Caps & Wheelcovers

Your Thunderbird will instantly look better when you use our new wheelcovers. These are highly detailed, accurately reproduced & beautifully rendered. In fact, the center emblem on the '55 & '56 wheelcover is currently being produced on the original Ford dies! Whatever your Bird requires, we have it here at MAC's. See pages 21 & 156.



## To Our Thunderbird Enthusiasts,

Legend has it that long ago, the Quillayute, part of the Native American Chimakoan tribe in the Pacific Northwest, experienced the worst weather they had ever seen. It began with rainstorms, which gave way to hail, sleet, then snow. Hailstones were so large that many among the tribe were killed. Others were forced to move from their villages. The water froze over so the men could not fish. The vegetation that was not already eaten was ruined.

The Chief finally called his people together to ask the Great Spirit for help. After many futile attempts, they saw flashes of light and heard a loud, whirring sound. They looked to the sky and saw a huge bird-like creature coming toward them. Its wingspan was as wide as two war canoes. It circled several times then flew away, taking with it the lightning, thunder, and rain. The Thunderbird—as the tribe called it because of the powerful sound it made—had saved the Quillayute.

It's only fitting, then, that the name Thunderbird is also used for these powerful, classic autos.

In the tradition of that great bird, MAC's has produced what we feel is the most complete catalog of classic Thunderbird parts in the world. Enthusiasts like you will enjoy the more than 8,000 items listed on 264 pages in full color. This year we also have added more than 285 NEW items to the catalog.

**Ordering is extremely easy.** You can use our Web site [www.macsaautoparts.com](http://www.macsaautoparts.com), fax or mail your order using an order form (found on pages 258, 260 & 262 of this catalog), or call 800-777-0948 to speak with one of our dedicated staff members.

Stop in & visit our **new showroom** at 6150 Donner Road in Lockport, New York (minutes from Buffalo), 8 a.m.-5:30 p.m. Monday-Friday or 8 a.m.-12:30 p.m. on Saturday. You can check out some cars, pick up your order, or just say hello.

When it comes to restoring & maintaining your classic Thunderbird, we know you have choices, so we thank you for choosing MAC's: your one stop source for quality parts & accessories for your 1909-1970s Ford & Mercury.

*Rick & Randy McIntosh  
& the staff of MAC's Antique Auto Parts*



## CATALOG DEPARTMENT

<b>Catalog Manager</b>	Lloyd J. Lathrop, Jr.
<b>Technical Illustration/Photography</b>	Rodell D. Sanford Jr. Mike Weber Dennis Stierer
<b>Graphic Design &amp; Layout</b>	Brandon Hattaway
<b>Research</b>	Beth Schaffer Mike Rovillo Bill Barrile

# Here's what our customers are saying about MAC's...

**Without a doubt**, MAC's is the most professional early Ford parts supplier in the industry. I've tried others here on the west coast, but their reaction to me is almost nil, from lousy service to totally ignoring my orders. Thanks again from California to MAC's in New York.

- Gil H.

**Every contact I have** with MAC's has been nothing but prompt, professional & perfect. MAC's was on this job & will be my first (and ... only) choice in the future ... I always recommend MAC's to others.

- Shayne M. Campbell

**I have found your prices** better than eBay parts. You guys get me the order so fast! You are very helpful with my [restoration]. It will be fantastic, thanks to all of you at MAC's.

- John Mannes

## Icon Descriptions

We have added these icons throughout our catalog where necessary & are used to denote any additional information you need about our parts. We want your ordering experience with us to be as pleasant as possible.



These hot deals have been designed to save you money on combinations of parts often needed to complete a repair!



These items are new to this year's catalog.



Because of size or weight, the freight charges will be higher on these items.



Because of size or weight, these items can only be shipped by truck.



Our resident expert, Mac, offers helpful hints & sound advice.

The sections of our Thunderbird catalog are listed below & are tabbed to make them easier to find.



## 1955-57 Little Bird

Parts Listings . . . . . 2-87  
Detailed Index . . . . . 88-94



## Decals, Restoration, Books, Accessories & Novelties

Parts Listings . . . . . 95-129



## 1958-66 Big Bird

Parts Listings . . . . . 132-245  
Detailed Index . . . . . 245-253

## How To Use THIS CATALOG



These page headers tell you which area of your car the parts on the page are for.

### INTERIOR TRIM

#### Door Garnish Rails

55-57 Door garnish rail, metal, right . . . . . B5S-4020906-B  
55-57 Door garnish rail, metal, left . . . . . B5S-4020907-B

These sub-headers tell you which specific parts are listed below it.

#### Door Garnish Rail Vinyl Sets

The 3-piece sets listed below include covers for right & left door garnish rails & the rear garnish rail, at the deck area behind the seat.

1955 **NEW** Black #LB13 . . . . . B5S-4020906-B  
1955 Dark green #LB24 . . . . . B5S-4020907-B

This italicized text is technical information about the parts listed below it.

This is the order of our listings:

Years of Application	Part Description	Part Number	Price
1955	Finish plate, 1 hole, used in early 1955 only, left (4 required)	B5S-4021145-A	41.95

Numbers in parentheses & italics are the recommended number required.





## Seat Cover Sets

Although not our Cartouche brand, these seat covers for 1955 Fords are top quality. Great care was taken to locate the correct grain vinyl & pattern cloth so these seat covers would have a level of authenticity not seen before. Call us today so we can get a set of these beautiful new seat covers on their way to you!

All seat sets include covers for the cushion & the backrest, backrest hinge "Booties" & the wings that go between the edge of the backrest & the backrest cardboard. Covers are sewn & constructed to duplicate the original Thunderbird style in every possible way.

### 2-TONE SEAT COVER COLORS:

First color listed is the "outline" color; second color listed is the "insert" color.



All seat covers are oversize & required additional shipping charges.

### Standard Seat Covers: 1955



Black with white insert . . . . .	ULF-400	224.95 set
Red with white insert . . . . .	ULF-401	224.95 set
Turquoise with white insert . . . . .	ULF-402	224.95 set
Black with yellow insert . . . . .	ULF-403	270.95 set



**Unsure of the color?  
Order SAMPLE4, it's free!**

### Colors available for 1955 Thunderbirds



1955 ULF-400

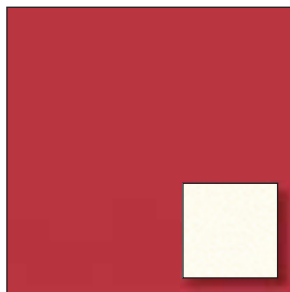

1955 ULF-401

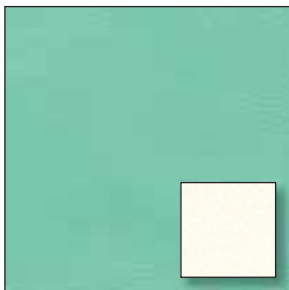

1955 ULF-402



1955 ULF-403

**SEAT COVER EMBOSSING:** All 1956 & early 1957 Thunderbirds came from the factory with an emblem embossed in the center of the backrest. A Ford crest was featured on 1956 models. A Thunderbird logo was featured on the very early 1957 models. These embossings were discontinued during the 1957 model year.

### Standard Seat Covers: 1956



LOGO  
DETAIL

Black with white insert, plain (no logo) . . . . .	ULF-404	224.95 set
Black with white insert, embossed (with logo) . . . . .	ULF-405	265.95 set
Fiesta red with white insert, plain . . . . .	ULF-406	224.95 set
Fiesta red with white insert, embossed . . . . .	ULF-407	252.95 set
Peacock with white insert, plain . . . . .	ULF-408	224.95 set
Peacock with white insert, embossed . . . . .	ULF-409	252.95 set
Buckskin with white insert, plain . . . . .	ULF-410	224.95 set
Buckskin with white insert, embossed . . . . .	ULF-411	252.95 set
Sage green with white insert, plain . . . . .	ULF-412	224.95 set
Sage green with white insert, embossed . . . . .	ULF-413	252.95 set

### Colors available for 1956 Thunderbirds



1956 ULF-404 & ULF-405

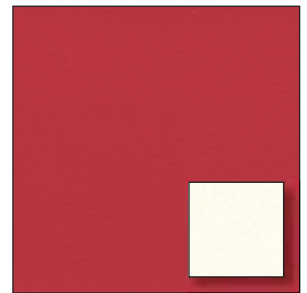

1956 ULF-406 & ULF-407

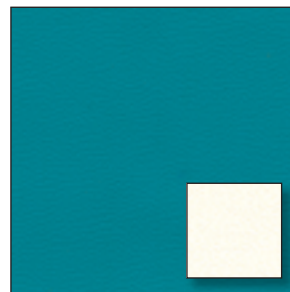

1956 ULF-408 & ULF-409

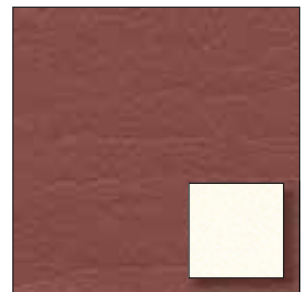

1956 ULF-410 & ULF-411

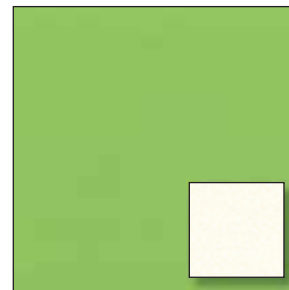

1956 ULF-412 & ULF-413





## Standard Seat Covers: 1957



LOGO  
DETAIL

Black with white insert, plain (no logo) . . . . .	ULF-414	224.95 set
Black with white insert, embossed (with logo) . . .	ULF-415	252.95 set
Solid white, plain . . . . .	ULF-416	224.95 set
Solid white, embossed . . . . .	ULF-417	252.95 set
Dresden blue with starmist blue insert, plain . . .	ULF-418	224.95 set
Dresden blue with starmist blue insert, embossed . . . . .	ULF-419	252.95 set
Solid red, plain. . . . .	ULF-420	224.95 set
Solid red, embossed . . . . .	ULF-421	252.95 set
Solid bronze, plain. . . . .	ULF-422	224.95 set
Solid bronze, embossed . . . . .	ULF-423	252.95 set
Cumberland green with willow green insert, plain . . . . .	ULF-424	224.95 set
Cumberland green with willow green insert, embossed . . . . .	ULF-425	298.95 set

### Colors available for 1957 Thunderbirds



1957 ULF-414 & ULF-415

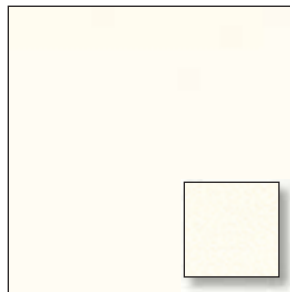

1957 ULF-416 & ULF-417

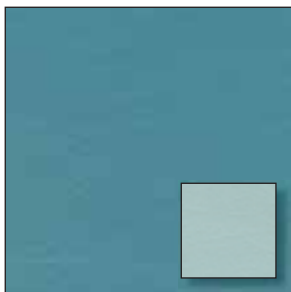

1957 ULF-418 & ULF-419

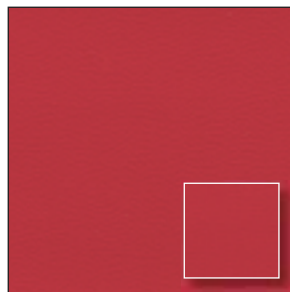

1957 ULF-420 & ULF-421

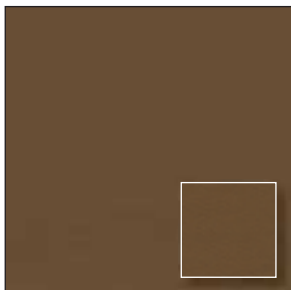

1957 ULF-422 & ULF-423

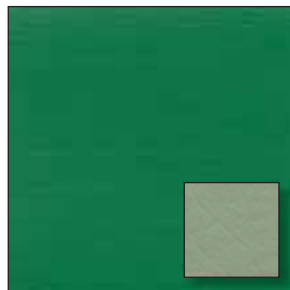

1957 ULF-424 & ULF-425

## Seat Foam Sets

The key to a good looking, comfortable ride is your seat foam. New seat foam makes the installation of new seat covers easier, with a proper fit. If you are getting new seat covers, you should really consider new seat foams as well!

1955	<b>NEW</b> OS	Seat foam set, seat & backrest, contoured to original shape. . . . .	U16BSF55	275.95 set
1956	<b>NEW</b> OS	Seat foam set, seat & backrest, contoured to original shape. . . . .	U16BSF56	275.95 set
1957	<b>NEW</b> OS	Seat foam set, seat & backrest, contoured to original shape. . . . .	U16BSF57	275.95 set

## Seat Backrest Panels (Cardboard)

Our seat backrest panels listed below are covered with the correct colored vinyl & feature vinyl edge binding as original. Unsure of the color? Order SAMPLE4, it's free!



1955	Black . . . . .	B5S-64416-BLK	35.95
1955	Green . . . . .	B5S-64416-GRN	35.95
1955	Red . . . . .	B5S-64416-RED	35.95
1956	Buckskin . . . . .	B6S-64416-BKSKN	35.95
1956	Green . . . . .	B6S-64416-GRN	35.95
1956	Peacock. . . . .	B6S-64416-PECO	35.95
1956	Red . . . . .	B6S-64416-RED	35.95
56-57	Black . . . . .	B6S-64416-BLK	37.95
1957	Blue . . . . .	B7S-64416-BLU	35.95
1957	Bronze . . . . .	B7S-64416-BRNZ	35.95
1957	Green . . . . .	B7S-64416-GRN	35.95
1957	Red . . . . .	B7S-64416-RED	35.95
1957	White . . . . .	B7S-64416-WHT	35.95

## Hog Ring Pliers & Rings

We offer high quality hog rings & pliers, for those who are skilled at installing their own seat covers. However, if you have never done this job before, we recommend that you take our premium seat cover sets to a professional trim installer, for best results. Their many years of experience have taught them countless techniques for getting the proper fit, without unnecessary wrinkles, sags, or other little imperfections. So unless you are experienced at installing reproduction automotive seat covers, check the yellow pages for a professional installer near you.



### Hog Ring Pliers

ALL **NEW** Professional quality. . . . . T4407U 25.25

### Hog Rings

ALL **NEW** 100 pieces . . . . . T4406U 2.95 set



## Power Seat Parts

### Power Seat Switch Parts

- 55-57 Power seat switch housing, with correct lettering: "4 Way Seat" . . . B4A-14685-A 34.95
- 55-57 Power seat switch, female plug type . . . . . B5AZ-14A701-A 41.95
- 55-57 Power seat switch gasket . . . . . B4A-14686 5.95
- 55-57 Power seat regulator coupling (2 required) . . . . . BC-7023279-A 11.95



- 55-57 Power seat switch to housing clip (3 required) . . . . . FAA-14570-A 3.95



- 56-57 Power seat worm gear kit, includes plastic tube, clamp & cardboard spacer . . . . . B6S-60477-KT 13.95 kit

### Power Seat Relays

- 1955 Power seat relay, 6 volt, replacement type . . . . . B5S-14512 35.95
- 56-57 Power seat relay, 12 volt, replacement type . . . . . B6S-14512 35.95

### Power Seat Regulator Supports

- 55-57 Vertical support, for power seat regulator . . . . . B5S-4060440-A 17.95
- 55-57 Horizontal support, for power seat regulator . . . . . B5S-4060441-A 17.95

### Power Seat Track Assist Spring



- 56-57 Power seat track assist spring (2 required) . . . . . B6S-4061828-A 6.95

### Seat Stop Plates



- 55-57 Seat stop plates, with screws . . . . B5S-4061642-A 8.95 pair

## Manual Seat Parts

### Manual Seat Adjuster Handle



- 55-57 Manual seat adjuster handle, black plastic as original, manual seat only . . . . . B5A-7061755-A 15.95

### Manual Seat Track Assist Spring



- 56-57 Seat track assist spring, manual seat only (2 required) . . . . . B6S-4061828-A 6.95

### Manual Seat Track Cable

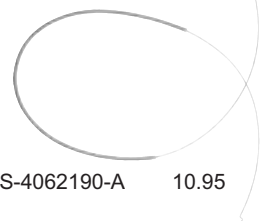

- 55-57 Manual seat track cable, manual seat only . . . . . B5S-4062190-A 10.95

### Seat Adjustable Lever Shield



- 55-57 Seat adjustment lever shield . . . . . B5S-4062198-A 9.95

## Tonneau Cover Kits

The Tonneau cover vinyl is the same color & texture as our seat covers & door panels for a perfect match. Tonneau covers have a zipper down the center so that either side can be opened independently of the other. Body & cover snaps & grommets are included, but not installed.



- 1955 Black . . . . . B5S-50134-BLK 179.95 kit
- 1955 Green . . . . . B5S-50134-GRN 179.95 kit
- 1955 Red . . . . . B5S-50134-RED 179.95 kit
- 55-56 White . . . . . B5S-50134-WHT 179.95 kit
- 1956 Black . . . . . B6S-50134-BLK 179.95 kit
- 1956 Buckskin . . . . . B6S-50134-BKSK 179.95 kit
- 1956 Sage green . . . . . B6S-50134-GRN 179.95 kit
- 1956 Peacock . . . . . B6S-50134-PECO 179.95 kit
- 1956 Fiesta red . . . . . B6S-50134-RED 179.95 kit
- 1957 Black . . . . . B7S-50134-BLK 179.95 kit
- 1957 Dresden blue . . . . . B7S-50134-BLU 179.95 kit
- 1957 Bronze . . . . . B7S-50134-BRNZ 179.95 kit
- 1957 Cumberland green . . . . . B7S-50134-GRN 179.95 kit
- 1957 Red . . . . . B7S-50134-RED 179.95 kit
- 1957 White . . . . . B7S-50134-WHT 179.95 kit





**Seat Belts** (2 required)

If you haven't already installed seat belts in your classic ride, we highly recommend it. Our universal style seat belts feature a chrome lift latch & are available in 10 colors to match almost any interior. Sold per passenger, each belt includes washers, bolts, nuts & basic instructions on how (but not where) to install. The 60" size is standard, for a little extra breathing room, order the 74" length. Proper installation is at the risk & responsibility of the customer.



**Seatbelt Ordering Instructions:**

The part numbers for each color are located under the color swatch, with corresponding numbers for length (ex: SEATBELT-BLK60, is for the 60" belt, while SEATBELT-BLK74 is for the 74" belt).

60" Belts	.....	.23.95 each
74" Belts	.....	.26.95 each

**60" Long**

ALL	Black, 60" long	.....	SEATBELT-BLK60	23.95
ALL	White, 60" long	.....	SEATBELT-WHT60	23.95
ALL	Light gray, 60" long	.....	SEATBELT-LGR60	23.95
ALL	Dark gray, 60" long	.....	SEATBELT-DGR60	23.95
ALL	Light tan, 60" long	.....	SEATBELT-LTN60	23.95
ALL	Dark tan, 60" long	.....	SEATBELT-DTN60	23.95
ALL	Light blue, 60" long	.....	SEATBELT-LBL60	23.95
ALL	Dark blue, 60" long	.....	SEATBELT-DBL60	23.95
ALL	Bright red, 60" long	.....	SEATBELT-BRD60	23.95
ALL	Dark red, 60" long	.....	SEATBELT-DRD60	23.95

**74" Long**

ALL	Black, 74" long	.....	SEATBELT-BLK74	26.95
ALL	White, 74" long	.....	SEATBELT-WHT74	26.95
ALL	Light gray, 74" long	.....	SEATBELT-LGR74	26.95
ALL	Dark gray, 74" long	.....	SEATBELT-DGR74	26.95
ALL	Light tan, 74" long	.....	SEATBELT-LTN74	26.95
ALL	Dark tan, 74" long	.....	SEATBELT-DTN74	26.95
ALL	Light blue, 74" long	.....	SEATBELT-LBL74	26.95
ALL	Dark blue, 74" long	.....	SEATBELT-DBL74	26.95
ALL	Bright red, 74" long	.....	SEATBELT-BRD74	26.95
ALL	Dark red, 74" long	.....	SEATBELT-DRD74	26.95

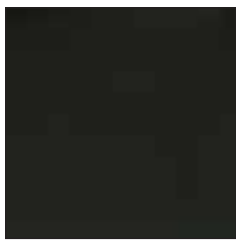

SEATBELT-BLK60  
SEATBELT-BLK74



SEATBELT-WHT60  
SEATBELT-WHT74



SEATBELT-LGR60  
SEATBELT-LGR74



SEATBELT-DGR60  
SEATBELT-DGR74



SEATBELT-LTN60  
SEATBELT-LTN74



SEATBELT-DTN60  
SEATBELT-DTN74

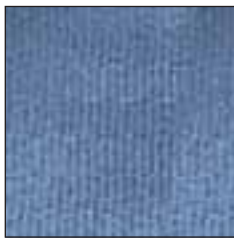

SEATBELT-LBL60  
SEATBELT-LBL74



SEATBELT-DBL60  
SEATBELT-DBL74



SEATBELT-BRD60  
SEATBELT-BRD74



SEATBELT-DRD60  
SEATBELT-DRD74



## Carpets

MAC's offers simply the finest carpets money can buy to complete your restored interior. MAC's premium carpet sets are made with the highest quality materials. Just like the original equipment, these "80/20" carpets are color-fast 80/20 loop pile created for wear resistance & durability. The nylon molded carpets are 100% loop pile nylon. Both versions are molded & have Jute backing installed on the undersides in the correct sizes & shapes. All are made to your car's specifications assuring a proper fit. Most carpets ship within 48 hours. Features include: 6 factory colors to chose from, serge bound edges where original, color-keyed vinyl heel pad, pre-installed jute backing & are made to fit like originals. Please specify color when ordering!

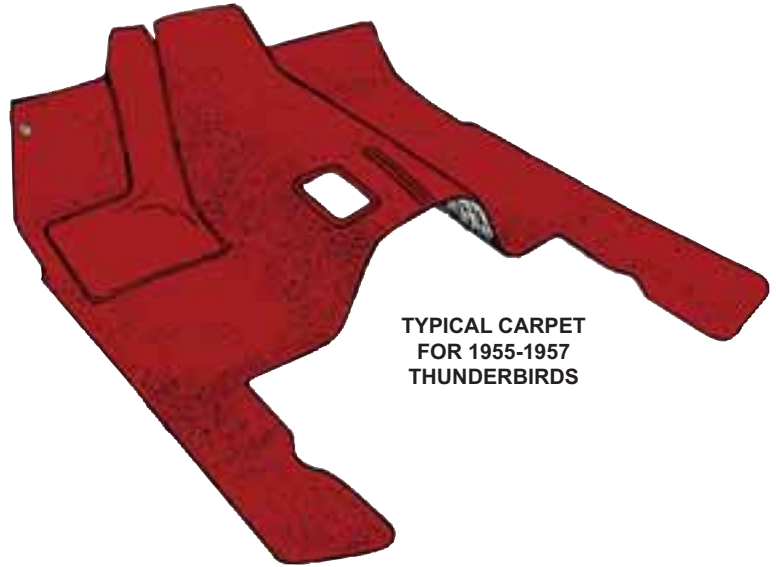

TYPICAL CARPET FOR 1955-1957 THUNDERBIRDS

### Carpets

55-57	Molded 80/20 carpet, black #11, red #12, aqua #24, blue #54, light saddle #45. . . . .	5557-BIRD-80/20	164.95
55-57	Molded nylon carpet, black #61, red #62, aqua #63, light blue #64, saddle #65. . . . .	5557-BIRD-NYLON	164.95
55-57	One yard of loop pile carpet in the color of your choice. . . . .	CARPETYARD	44.95 yard

### Sample Card

55-57	All colors currently available for Thunderbirds . . . . .	SAMPLE4	FREE
-------	-----------------------------------------------------------	---------	------



Unsure of the color? Order SAMPLE4, it's free!

## Thunderbird



Black #11 or #61

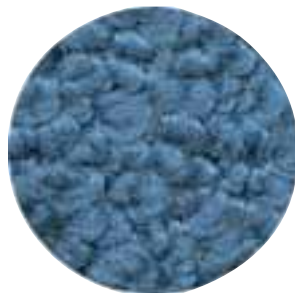

Light Blue #64



Red #12 or #62



Blue #54



Light Saddle #45 or #65



Aqua #24 or #63

**WHEN ORDERING FLOOR CARPETS...**  
WE WILL NEED THE FOLLOWING INFORMATION:

- 1) Year, Make & Model of your car.
- 2) Body style of your car (found on Patent/Warranty Plate, drivers door)
- 3) Front seat type (power or not)
- 4) Transmission type (manual or automatic)
- 5) Color (see carpet color choices above)

**REMEMBER:**  
Don't remove your OLD carpet until your NEW carpet arrives!





## Floor Mats



### Rubber Floor Mats

- 55-57 Black with white "Thunderbird" script & bird logo . . . . . 13086-PRB 79.95 pair
- 55-57 Red with white "Thunderbird" script & bird logo . . . . . 13086-PRR 79.95 pair
- 55-57 Medium green with white "Thunderbird" script & bird logo (shown) . . . . . 13086-PRA 79.95 pair
- 55-57 Medium blue with white "Thunderbird" script & bird logo . . . . . 13086-PRMB 79.95 pair



### Carpeted Floor Mats

Please specify color when ordering!

- 55-57 2-pieces, 80/20 carpet, black #11, red #12, aqua #24, blue #54, light saddle #45. . . . . 7770-PLAIN 64.95 pair
- 55-57 2-pieces with logo, 80/20 carpet, please specify logo number when ordering! black #11, red #12, aqua #24, blue #54, light saddle #45, custom order, not returnable . . . . . 7770-LOGO 104.95 pair

### AVAILABLE LOGOS



116



148

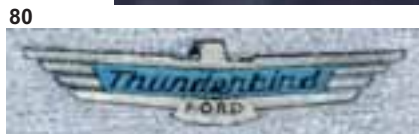

80

## Insulation & Sound Deadener (as required)

### Firewall Insulation



If you are replacing your carpet, now is the best time to install superior firewall insulation. We carry everything you'll need. Our big 48" x 72" sheet is a full 5/16" thick & is rated to R18 (meaning it resists heat up to 700°). It's constructed of jute fiber with a space age reflective foil bonded to both sides. You can put it on the firewall, behind the kick panels or even on the trunk divider. It does the job of blocking intrusive road noise & keeping engine heat in the engine compartment where it belongs.

- ALL Firewall insulation, 48" x 72" x 5/16", cut to fit desired area . . . . . V700770X 32.00

### Sound Deadener by Dynamat®



For years, we have been selling the original Dynamat & can boast hundreds of satisfied customers. We are now proud to offer the next generation of Dynamat sound deadeners: Xtreme. Xtreme is a step up from the original formula & is Dynamat's best product at controlling vibration. It damps 4 times as much as the original Dynamat &, as an added bonus, it weighs 50% less. It is available in conveniently sized 18" x 32" sheets & with peel & stick application; it goes on quickly & easily. Do yourself a favor & order some today!

- ALL  Dynamat® Xtreme, each piece is 18" x 32" (as required) . . . . . DYNAMAT-0433 29.95

### Jute Backing



Ever wonder what that stuff is on the back of your carpet? It's called jute fiber & it provides a cushion underneath your carpet as well as sound insulation. We have it available in 36" x 72" sheets that are 5/16" thick. You cut the size you need for the area you want to put it in.

- ALL Synthetic jute fiber, 36" x 72" x 5/16", cut to fit . . . . . B13000 15.95

### General Trim Adhesive

MAC's recommends the following adhesive for attaching jute padding to metal or plastic.



- ALL Adhesive, 18.1 oz. spray. . . . . RSP29 \* 14.75

\* **HAZARDOUS MATERIAL** can only be shipped by ground/ surface within the U.S. because of government regulations.



## Sun Visors

These original-style sun visors are the best ever! They are constructed of vinyl that is color-matched to go with our upholstery.



TYPICAL SUNVISOR

1956	White	B6S-4004104-WHT	160.95 pair
1957	White	B7S-4004104-WHT	182.95 pair
1957	Red	B7S-4004104-RED	182.95 pair
1957	Blue	B7S-4004104-BLU	182.95 pair
1957	Green	B7S-4004104-GRN	182.95 pair
1957	Bronze	B7S-4004104-BRZ	182.95 pair

## Sun Visor Anchor Pin (2 required)



55-57	Sun visor anchor pin	B5S-4004114-A	5.95
-------	----------------------	---------------	------

## Sun Visor Clip (2 required)



56-57	Chrome	B6S-4004132-A	22.95
-------	--------	---------------	-------

## Sun Visor Brackets & Rods

1956	Right, chrome	B6S-4004144-A	45.95
1956	Left, chrome	B6S-4004145-A	45.95
1957	Right, chrome	B7S-4004144-A	45.95
1957	Left, chrome	B7S-4004145-A	45.95

## Kick Panels

The kick panels listed below are sold in pairs only. Kick panels for 1955 have heat-seamed channels; kick panels for 1956 have simulated stitched seams; kick panels for 1957 feature the embossed Thunderbird emblem.



**Unsure of the color?  
Order SAMPLE4, it's free!**

1955	White #LB11	B5S-02348-WHT	59.95 pair
1955	Yellow #LB22	B5S-02348-YELW	83.95 pair
1956	White #LB11	B6S-02348-WHT	59.95 pair

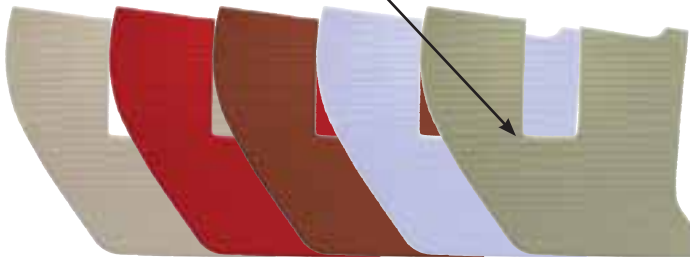

1957	White #LB14	B7S-02348-WHT	59.95 pair
1957	Red #LB15	B7S-02348-RED	83.95 pair
1957	Bronze #LB43	B7S-02348-BRNZ	83.95 pair
1957	Willow green #LB44	B7S-02348-WGRN	83.95 pair
1957	Starmist blue #LB41	B7S-02348-SMBLU	83.95 pair

## Kick Panel Retainers



55-57	Right (shown)	B5S-4002354-BP	49.95
55-57	Left	B5S-4002355-BP	63.95

## Cloth Covered Windlace

Cloth covered windlace was correct for both 1955-56 T-birds. Each windlace set contains 4 pieces that install on the front & rear of each door. Original-type.



1955	Red	WLC-5502600-RED	25.95 set
1956	Red	WLC-5602600-RED	25.95 set
1956	Black	WLC-5602600-BLK	25.95 set
1956	Peacock (turquoise)	WLC-5602600-PECO	25.95 set
1956	Green	WLC-5602600-GRN	25.95 set



**Unsure of the color?  
Order SAMPLE4, it's free!**

## Vinyl Covered Windlace

Vinyl covered windlace was correct for 1957 model T-birds. Each windlace set contains 4 pieces that install on the front & rear of each door.



1955	Black #LB12	WLV-5502600-BLK	25.95 set
1955	Green #LB24	WLV-5502600-GRN	25.95 set
1955	Red #LB21	WLV-5502600-RED	25.95 set

1956	Black #LB12	WLV-5502600-BLK	25.95 set
1956	Buckskin #LB33	WLV-5602600-BKSK	25.95 set
1956	Sage green #LB34	WLV-5602600-GRN	25.95 set
1956	Peacock #LB32	WLV-5602600-PECO	25.95 set
1956	Fiesta red #LB31	WLV-5602600-RED	25.95 set

1957	Black #LB13	WLV-5702600-BLK	27.95 set
1957	Starmist blue #LB41	WLV-5702600-BLU	27.95 set
1957	Bronze #LB43	WLV-5702600-BRNZ	27.95 set
1957	Willow green #LB44	WLV-5702600-GRN	27.95 set
1957	Red #LB15	WLV-5702600-RED	27.95 set
1957	White #LB14	WLV-5702600-WHT	27.95 set



**Unsure of the color?  
Order SAMPLE4, it's free!**





**Vinyl Floor Covers**

Color-matched to our seat covers, the vinyl floor covers listed below cover the area between the seatback & the drop curtain.  
NOTE: 1955-56 covers transmission hump only; 1957 covers are full width. Unsure of the color? Order SAMPLE4, it's free!



- |       |                                                 |                |       |
|-------|-------------------------------------------------|----------------|-------|
| 1955  | Covers transmission hump only, green #LB24      | B5S-13002-GRN  | 7.95  |
| 1955  | Covers transmission hump only, red #LB21        | B5S-13002-RED  | 7.95  |
| 55-56 | Covers transmission hump only, black #LB12      | B5S-13002-BLK  | 7.95  |
| 1956  | Covers transmission hump only, buckskin #LB33   | B6S-13002-BKSK | 7.95  |
| 1956  | Covers transmission hump only, sage green #LB34 | B6S-13002-GRN  | 7.95  |
| 1956  | Covers transmission hump only, peacock #LB32    | B6S-13002-PECO | 7.95  |
| 1956  | Covers transmission hump only, fiesta red #LB31 | B6S-13002-RED  | 7.95  |
| 1957  | Black #LB13                                     | B7S-13002-BLK  | 15.95 |
| 1957  | Dresden blue #LB42                              | B7S-13002-BLU  | 15.95 |
| 1957  | Bronze #LB43                                    | B7S-13002-BRNZ | 15.95 |
| 1957  | Cumberland green #LB45                          | B7S-13002-GRN  | 15.95 |
| 1957  | Red #LB15                                       | B7S-13002-RED  | 15.95 |
| 1957  | White #LB14                                     | B7S-13002-WHT  | 15.95 |

**Vinyl Drop Curtains**

These have snaps already installed. Unsure of the color? Order SAMPLE4, it's free!

- |       |                        |            |       |
|-------|------------------------|------------|-------|
| 1955  | Green #LB24            | DC555-GRN  | 43.95 |
| 1955  | Red #LB21              | DC555-RED  | 43.95 |
| 55-56 | Black #LB12            | DC556-BLK  | 43.95 |
| 1956  | Buckskin #LB33         | DC566-BKSK | 43.95 |
| 1956  | Sage green #LB34       | DC566-GRN  | 43.95 |
| 1956  | Peacock #LB32          | DC566-PEC  | 43.95 |
| 1956  | Fiesta red #LB31       | DC566-RED  | 43.95 |
| 1957  | Black #LB13            | DC577-BLK  | 45.95 |
| 1957  | Dresden blue #LB42     | DC577-BLU  | 45.95 |
| 1957  | Bronze #LB43           | DC577-BRZ  | 45.95 |
| 1957  | Cumberland green #LB45 | DC577-GRN  | 45.95 |
| 1957  | Red #LB15              | DC577-RED  | 45.95 |
| 1957  | White #LB14            | DC577-WHT  | 45.95 |

**Door Garnish Rails**



- |       |                                 |               |       |
|-------|---------------------------------|---------------|-------|
| 55-57 | Door garnish rail, metal, right | B5S-4020906-B | 55.95 |
| 55-57 | Door garnish rail, metal, left  | B5S-4020907-B | 55.95 |

**Door Garnish Rail Vinyl Sets**

The 3-piece sets listed below include covers for right & left door garnish rails & the rear garnish rail, at the deck area behind the seat.



**Unsure of the color?  
Order SAMPLE4, it's free!**

- |      |                        |                  |           |
|------|------------------------|------------------|-----------|
| 1955 | Black #LB12            | B5S-4020906-BLK  | 15.95 set |
| 1955 | Green #LB24            | B5S-4020906-GRN  | 15.95 set |
| 1955 | Red #LB21              | B5S-4020906-RED  | 15.95 set |
| 1956 | Black #LB12            | B6S-4020906-BLK  | 15.95 set |
| 1956 | Buckskin #LB33         | B6S-4020906-BKSK | 15.95 set |
| 1956 | Sage green #LB34       | B6S-4020906-GRN  | 15.95 set |
| 1956 | Peacock #LB32          | B6S-4020906-PECO | 15.95 set |
| 1956 | Fiesta red #LB31       | B6S-4020906-RED  | 15.95 set |
| 1957 | Black #LB13            | B7S-4020906-BLK  | 15.95 set |
| 1957 | Dresden blue #LB42     | B7S-4020906-BLU  | 15.95 set |
| 1957 | Bronze #LB43           | B7S-4020906-BRNZ | 15.95 set |
| 1957 | Cumberland green #LB45 | B7S-4020906-GRN  | 15.95 set |
| 1957 | Red #LB15              | B7S-4020906-RED  | 15.95 set |
| 1957 | White #LB14            | B7S-4020906-WHT  | 15.95 set |

**Door Garnish Moulding**



- |       |                            |               |       |
|-------|----------------------------|---------------|-------|
| 55-57 | Right or left (2 required) | B5S-4021172-A | 32.95 |
|-------|----------------------------|---------------|-------|

**Door Garnish Finish Plates**



- |       |                                                              |               |       |
|-------|--------------------------------------------------------------|---------------|-------|
| 1955  | Finish plate, 1 hole, used in early 1955 only, right (shown) | B5S-4021144-A | 41.95 |
| 1955  | Finish plate, 1 hole, used in early 1955 only, left          | B5S-4021145-A | 41.95 |
| 55-57 | Finish plate, 2 holes, right (shown)                         | B5S-4021144-B | 16.95 |
| 55-57 | Finish plate, 2 holes, left                                  | B5S-4021145-B | 16.95 |

# INTERIOR TRIM



## Upper Door Trim Panels & Wedge Spacers



- 55-57 Upper door trim panel, aluminum, right . . . . . B5S-4021166-R 96.95
- 55-56 Upper door trim panel, with hole cut for power window switch, aluminum, left (not shown) . . . B6S-4021167-HL 106.95
- 55-57 Upper door trim panel, without power windows, aluminum, left . . . . . B5S-4021167-L 96.95



- 55-57 Upper door trim panel moulding, L shaped, right . . . . . B6S-4020920-R 16.95
- 55-57 Upper door trim panel moulding, L shaped, left. . . . . B6S-4020921-L 16.95



- 55-57 Wedge spacer for door trim moulding, right (shown). . . . . B5S-4021134-CP 44.95
- 55-57 Wedge spacer for door trim moulding, left. . . . . B5S-4021135-CP 44.95

## Door Trim Panels & Retainer

All door panels are sold in pairs, 1 panel per door. The panels are die-cut for exact fit. All panels are heat-embossed as original. The 1957 panels are embossed with the Thunderbird logo.



- 1955 White #LB11 . . . . . B5S-23942-WHT 128.95 pair
- 1955 Yellow #LB22. . . . . B5S-23942-YELO 168.95 pair
- 1956 White #LB11 . . . . . B6S-23942-WHT 128.95 pair
- 1957 White #LB14 . . . . . B7S-23942-WHT 152.95 pair
- 1957 Red #LB15 (shown) . . . . . B7S-23942-RED 177.95 pair
- 1957 Bronze #LB43 . . . . . B7S-23942-BRNZ 168.95 pair
- 1957 Willow green #LB44 . . . . . B7S-23942-WGRN 168.95 pair
- 1957 Starmist blue #LB41 . . . . . B7S-23942-SMBLU 168.95 pair
- 1957 Door trim panel retainer, right or left (2 required) . . . . . B7S-4021032-RL 16.95



**Unsure of the color?  
Order SAMPLE4, it's free!**

## Armrest Covers

All armrest covers are vinyl, sewn as original, including new die-cut cardboard.

- 1955 Black #LB12 . . . . . B5S-24100-BLK 31.95 pair
- 1955 Green #LB24. . . . . B5S-24100-GRN 33.95 pair
- 1955 Red #LB21 . . . . . B5S-24100-RED 31.95 pair
- 1956 Black #LB12 . . . . . B6S-24100-BLK 31.95 pair
- 1956 Buckskin #LB33 . . . . . B6S-24100-BKSK 31.95 pair
- 1956 Sage green #LB34 . . . . . B6S-24100-GRN 31.95 pair
- 1956 Peacock #LB32. . . . . B6S-24100-PECO 31.95 pair
- 1956 Fiesta red #LB31. . . . . B6S-24100-RED 31.95 pair
- 1957 Black #LB13 . . . . . B7S-24100-BLK 31.95 pair
- 1957 Dresden blue #LB42. . . . . B7S-24100-BLU 31.95 pair
- 1957 Bronze #LB43 . . . . . B7S-24100-BRNZ 31.95 pair
- 1957 Cumberland green #LB45. . . . . B7S-24100-GRN 31.95 pair
- 1957 Red #LB15 . . . . . B7S-24100-RED 33.95 pair
- 1957 White #LB14 . . . . . B7S-24100-WHT 31.95 pair

## Armrest Bases & Foam



- 55-57 Armrest base, without cover, right . . . . . B5S-4024140-R 72.95
- 55-57 Armrest base, without cover, left . . . . . B5S-4024141-L 72.95
- 55-57 Foam kit, 2 pieces, . . . . . B5S-4024142-KT 6.95 kit
- 55-57 Foam kit, 2 pieces, adhesive backed, 1 kit does both armrests . . . B5S-4024141-BKT 8.95 kit

## Door Panel Water Shield

- 55-57 Kraft paper with poly backing, die-cut . . . . . B5S-23942-WS 15.95 pair

## Quarter Panel Cardboard

These panels are handcrafted from correctly-colored cardboard & fit between the door post & the rear wheelhouse area.



- 1955 Black, used with yellow interior. . . B5S-31012-BLK 27.95 pair
- 1955 White, used with all interior colors, **except** yellow . . . . . B5S-31012-WHT 27.95 pair
- 1956 Black . . . . . B5S-31012-BLK 27.95 pair
- 1956 Fiesta red . . . . . B6S-31012-RED 27.95 pair
- 1956 Buckskin . . . . . B6S-31012-BKSK 27.95 pair
- 1956 Sage green . . . . . B6S-31012-SAGE 27.95 pair
- 1956 Peacock. . . . . B6S-31012-PECO 27.95 pair
- 1957 White . . . . . B7S-31012-WHT 27.95 pair
- 1957 Red (shown) . . . . . B7S-31012-RED 28.95 pair
- 1957 Blue . . . . . B7S-31012-BLU 27.95 pair
- 1957 Bronze . . . . . B7S-31012-BRNZ 27.95 pair
- 1957 Green . . . . . B7S-31012-GRN 27.95 pair



### Correct for 1955:

The tops have sewn-in-back windows that cannot be opened, as original.

### Replacement-style for 1955-1957:

Non-original replacement features a horseshoe-shaped zipper, which goes up both sides & across the top of the back window. This non-original replacement provides a complete seal for the back window & can be lowered for ventilation.

### Correct for 1956-1957:

The tops have a straight zipper across the top of the back window, with flaps on both sides of the window, as original.

### Convertible Top Materials & Colors:

Tops are available in 32-36 oz. vinyl or "Stay-Fast" canvas. Tops are available with a black or white outside & black or tan inside. These tops feature a 5-year warranty\*. The materials available are listed below. The outer color is listed first & the inner color is listed second.



**Unsure of the color?  
Order SAMPLE4, it's free!**

- Black/Black Vinyl #CV11
- Black/Black "Stay-fast" moulding #CV13
- White/Black Vinyl #CV12
- Black/Tan "Stay-fast" moulding #CV14

**\*Because of the difficulty of installation, the warranty is void if the top is not professionally installed.**

## Soft Tops

Our top kits include the top covering, rear window, wire-on trim strips, tips & screws, windlace strips & tension pad strips. They do not include rear window straps or bow cover material. Outer color is listed first & the inner color is listed second.



### Original-Type Tops With Sewn-In Window: 1955

1955	Black/Black vinyl, #CV11	..... B5S-52700CV11	248.95 kit
1955	White/Black vinyl, #CV12	..... B5S-52700CV12	248.95 kit
1955	Black/Black "Stay-Fast," #CV13	..... B5S-52700CV13	481.95 kit
1955	Black/Tan "Stay-Fast," #CV14	..... B5S-52700CV14	481.95 kit

### Original-Type Tops With Straight Zipper: 1956-1957

56-57	Black/Black vinyl, #CV11	..... B6S-52700CV11	289.95 kit
56-57	White/Black vinyl, #CV12	..... B6S-52700CV12	289.95 kit
56-57	Black/Black "Stay-Fast," #CV13	..... B6S-52700CV13	539.95 kit
56-57	Black/Tan "Stay-Fast," #CV14	..... B6S-52700CV14	539.95 kit

### Replacement-Type Tops With Horseshoe Zipper: 1955-1957

55-57	Black/Black vinyl, #CV11	..... B7S-52700CV11	289.95 kit
55-57	White/Black vinyl, #CV12	..... B7S-52700CV12	289.95 kit
55-57	Black/Black "Stay-Fast," #CV13	..... B7S-52700CV13	539.95 kit
55-57	Black/Tan "Stay-Fast," #CV14	..... B7S-52700CV14	539.95 kit

For complete Soft Top Weatherstripping Kits & individual pieces see our **Weatherstripping**.

## Wire-on Tips

55-57	Wire-on tip, soft top, right	..... B5S-40514A00	7.95
55-57	Wire-on tip, soft top, left	..... B5S-40514A01	7.95

## Stainless Header Trim Retainers

55-57	Right	..... B5S-4050374-B	5.95
55-57	Left	..... B5S-4050375-B	5.95

## Tacking Strip Set



55-57	<b>NEW</b> Extruded vinyl replacement, pieces for both front & rear	..... B5S-4051278-A	16.95 set
-------	---------------------------------------------------------------------	---------------------	-----------

## Rear Tack Strip Channel

In most cars the rear tack strip retainer is rusted badly. Install this formed aluminum replacement & never worry about rust again!



55-57	Formed aluminum, at rear of top	..... B5S-50000	154.95
-------	---------------------------------	-----------------	--------

## Front Tack Strip Retainer Repair Kit

The front tack strip retainer is prone to rust. This kit has all the parts necessary to replace those rusty retainers. CNC machined for accuracy & galvanized, these new retainers will last a lifetime. Stainless steel pop-rivets are included to complete the kit.

55-57	For front tack strip retainers	..... B5S-51340-KT	35.95 kit
-------	--------------------------------	--------------------	-----------

## Frame Pin Kits

To replace all the pins in your top frame you need (1) 50300-A & either (1) 50300-B or (1) 50300-C.



55-57	Chrome, replaces riveted pins, 6 polished stainless steel pins & 6 clips, replaces riveted pins	..... 50300-A	33.95 kit
-------	-------------------------------------------------------------------------------------------------	---------------	-----------



55-56	Chrome, 12 polished stainless steel pins & 12 retainers, thru mid-1956	..... 50300-B	67.95 kit
56-57	Chrome, 16 polished stainless steel pins & 16 retainers, mid-1956 thru 1957 (shown)	..... 50300-C	84.95 kit

## Top Locating/Alignment Pins (2 required)

55-57	Front	..... B5S-4003458-B	10.95
55-57	Side	..... B5S-4050562-B	12.95





## Swing Bar Parts

### Assembly

55-57 Without feet . . . . . B5S-4051360-B 390.95

### Brackets

55-56 Early type, uses B5S-16789-A  
(6-3/4" long spring, right) . . . . . B5S-4053118-A 54.95  
55-56 Early type, uses B5S-16789-A  
(6-3/4" long spring, left) . . . . . B5S-4053119-A 54.95  
56-57 Late type, uses B6S-16789-A  
(4-1/2" long spring, right) . . . . . B6S-4053118-B 54.95  
56-57 Late type, uses B6S-16789-A  
(4-1/2" long spring, left) . . . . . B6S-4053119-B 54.95

### Springs (2 required)

55-56 6-3/4" long, 1955 thru  
mid-1956 . . . . . B5S-16789-A 8.95  
56-57 4-1/2" long, from mid-1956  
thru 1957 . . . . . B6S-16789-A 8.95

### Sleeve (2 required)

55-57 Frame to swing bar . . . . . B5S-51374-A 5.95

### Spring Washers (as required)

55-57 For soft top pins 354171-S & 357412-S . . . . . 53213 1.95  
55-57 For soft top sleeve . . . . . 51374-W 1.95  
55-57 For soft top pins 354170-S & 357412-S . 356214-S 1.95  
55-57 For soft top pins 354169-S . . . . . 356600-S 1.95

### Bolts (2 required)

55-57 Special eye bolt, 5/16"- 24 x 3" . . . . . B5S-4051396-A 2.95  
55-57 Swing bar foot adjusting bolt . . . . . B5S-53115 4.95

*Whether you need one piece of soft top weatherstripping, a partial seal kit or a complete seal kit for your soft top, see our Weatherstripping section.*

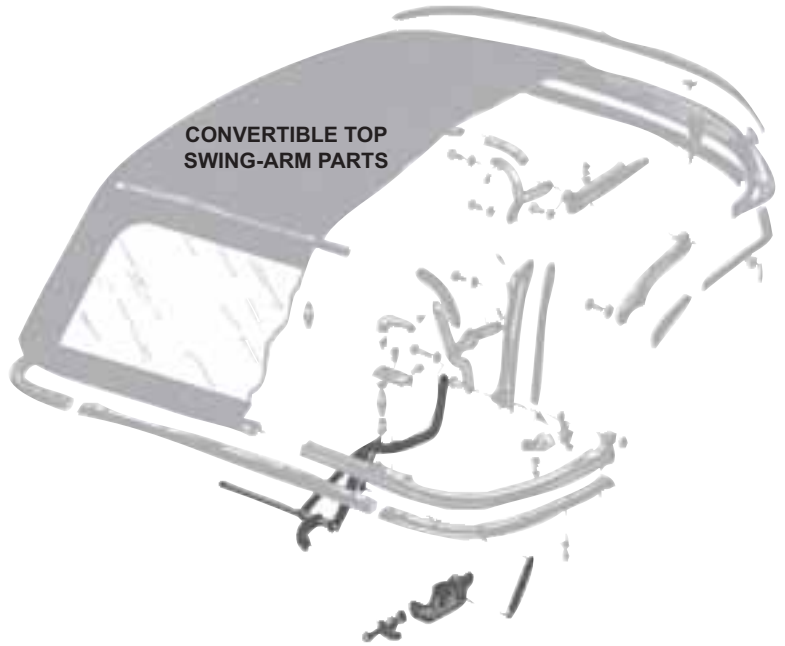

## Side Clamp Latch Plates

55-57 Right . . . . . B7S-4050502-A 63.95  
55-57 Left . . . . . B7S-4050503-A 63.95

## Side Clamps & "J" Hook (2 required)



55-56 Top side clamp, with "J" hook,  
hard & soft top . . . . . B5S-4050500-B 105.95  
1957 Top side clamp, with "J" hook,  
hard & soft top . . . . . B7S-4050500-A 105.95  
55-57 Top clamp "J" hook only, side . . . . . B5S-4050508-JS 18.95

## Front Clamps (2 required)



55-56 Top front clamp, for soft top,  
before 5-1-56 (shown) . . . . . B5S-4050508-A 105.95  
56-57 Top front clamp, for soft top,  
from 5-1-56 (shown) . . . . . B6S-4050508-A 105.95  
55-56 Top front clamp, for hard top,  
before 5-1-56 . . . . . B5S-4050508-B 105.95  
56-57 Top front clamp, for hard top,  
from 5-1-56 . . . . . B6S-4050508-B 105.95  
55-57 Top clamp "J" hook, front . . . . . B5S-4050508-JF 17.95

## Front Clamp Cup (2 required)



55-57 Front top clamp cup, in front  
above windshield . . . . . B5S-4050530-A 14.95

## Rear Clamp Levers



55-56 Right, dog-leg type, soft & hard top,  
thru mid-1956 . . . . . B5S-4050558-R 39.95  
55-56 Left, dog-leg type, soft & hard top,  
thru mid-1956 (shown) . . . . . B5S-4050559-L 39.95  
56-57 Right, straight type, soft & hard top,  
from mid-1956 (shown) . . . . . B6S-4050558-R 39.95  
56-57 Left, straight type, soft & hard top,  
from mid-1956 . . . . . B6S-4050559-L 39.95

## Rear Clamp Lever Return Springs

55-56 Right, for dog-leg type lever . . . . . B5S-4050584-A 2.95  
55-56 Left, for dog-leg type lever . . . . . B5S-4050585-A 2.95  
56-57 Right, for straight type lever . . . . . B6S-4050584-A 2.95  
56-57 Left, for straight type lever . . . . . B6S-4050585-A 2.95

*New rear window mouldings & roof emblems are available, please see our Emblems & Mouldings.*



Rear Deck Plates

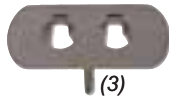
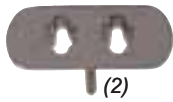
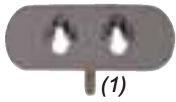

1955	Right (1)	.....	B5S-4050552-B	47.95
1955	Left (1)	.....	B5S-4050553-B	47.95
1956	Right, before 4-30-56 (2)	.....	B6S-4050552-A	47.95
1956	Left, before 4-30-56 (2)	.....	B6S-4050553-A	47.95
56-57	Right, from 5-1-56 (3)	.....	B6S-4050552-B	47.95
56-57	Left, from 5-1-56 (3)	.....	B6S-4050553-B	47.95

Rear Deck Plate Gaskets



55-57	For hard & soft tops	.....	B5S-4050534-PR	1.95 pair
-------	----------------------	-------	----------------	-----------

Rear Clamp Studs (2 required)



55-56	Fits dog-leg type lever.	.....	B5S-4050595-C	12.95
56-57	Fits straight type lever.	.....	B6S-4050595-A	12.95

Rear Hold-Down Clamp Retaining Plates



55-57	Right	.....	B5S-4050608-A	27.95
55-57	Left	.....	B5S-4050609-A	27.95

Top Rear Fasteners (2 required)



1955	Bullet shape with two pins.	.....	B5S-4050590-A	16.95
1956	Before 4-30-56	.....	B6S-4050590-A	16.95
56-57	Bullet shaped with one pin, from 5-1-56	.....	B6S-4050590-B	16.95

Ragg Top Cleaner & Protectants

Bring your top, top boot & vinyl items back to "showroom condition" with the RAGGTOPP cleaner & protection system.

Convertible Top Cleaner

- Safely removes tough stains
- Will not harm your top or other automotive finishes (glass, chrome or paint)
- Rinses off easily
- Environmentally friendly



ALL Restores original look, excellent cleaner for removing dirt, sap & bird droppings, 16 oz. bottle ..... RSP21438 11.95

Convertible Vinyl Top Protectant

- Has UV inhibitor to protect your top from the sun
- Repels mildew, dust, grease & dirt
- Contains no silicone
- Environmentally friendly



ALL For vinyl tops only, protects against hardening, cracking & UV fading, 16 oz. bottle ..... RSP11415 16.95

Convertible Fabric Top Protectant

- Protects against hardening, cracking & UV fading
- Extends life of older tops
- Helps maintain their appearance longer
- Extends the life of older tops



ALL For fabric tops only, 14 oz. spray can. .... RSP21414 \* 19.95

\* HAZARDOUS MATERIAL can only be shipped by ground/surface within the U.S. because of government regulations.



## Headliners

All headliners listed below include matching wire-on trim. All Little Birds used perforated vinyl headliners, available in white & bone. White is used for all 1955 & 1956 models, with or without portholes. Bone was the only color available in 1957. Sorry, no instructions are included.



White VH5



Bone VH6

1955	White, perforated vinyl . . . . .	3158-VH5	139.95
1956	White, perforated vinyl, 5-bow, for tops without portholes . . . . .	3168-VH5	139.95
1956	White, perforated vinyl, 4-bow, for tops with portholes. . . . .	3171-VH5	139.95
1957	Bone, perforated vinyl, 4-bow, for tops with portholes. . . . .	3181-VH6	59.95

## Headliner Bow Sets

55-56	4 pieces, for tops without portholes .	B5S-52104-ST	44.95 set
56-57	5 pieces, for tops with portholes . . . . .	B6S-52104-ST	53.95 set

## Headliner Bow Guide Clip (6 or 8 required)

55-57	CNC machined plastic replacement. . . . .	B5S-4052182-CLIP	3.95
-------	-------------------------------------------	------------------	------

## Headliner Wire-on Ends & Corners

55-57	End, stainless steel (2 required) . .	B5S-4051928-A	6.95
55-57	Corner, stainless steel (4 required) . . . . .	B5S-4051930-A	8.95

## Headliner Installation Tools



ALL	Headliner tool, economy model . . . . .	TOOL-7672	10.95
-----	-----------------------------------------	-----------	-------

*For a better grip, try our deluxe model with a wooden handle—it's just like the tool the professionals use!*



ALL	Headliner tool, deluxe model . . . . .	TOOL-13575	22.95
-----	----------------------------------------	------------	-------



ALL	Vinyl adhesive, 18.1 oz. spray can, 3M brand . . . . .	RSP29 *	14.75
-----	--------------------------------------------------------	---------	-------

\* **HAZARDOUS MATERIAL** can only be shipped by ground/surface within the U.S. because of government regulations.





## Alignment Dowel (2 required)

55-57 Dowel ..... B5S-4050562-A 11.95

## Lower Stainless Trim Clip

55-57 At rear center ..... B5S-4050390-A 8.95

## Rear Clamp Studs (2 required)



55-56 Fits dog-leg type lever..... B5S-4050595-C 12.95  
56-57 Fits straight type lever..... B6S-4050595-A 12.95

## Rear Clamp Levers



55-56 Right, dog-leg type, soft & hard top, thru mid-1956 ..... B5S-4050558-R 39.95  
55-56 Left, dog-leg type, soft & hard top, thru mid-1956 (shown) ..... B5S-4050559-L 39.95



56-57 Right, straight type, soft & hard top, from mid-1956 (shown) ..... B6S-4050558-R 39.95  
56-57 Left, straight type, soft & hard top, from mid-1956 ..... B6S-4050559-L 39.95

## Rear Deck Plates

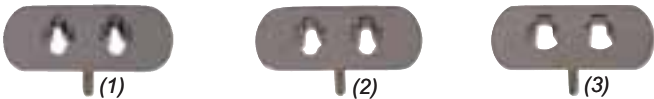

1955 Right (1) ..... B5S-4050552-B 47.95  
1955 Left (1) ..... B5S-4050553-B 47.95  
1956 Right, before 4-30-56 (2) ..... B6S-4050552-A 47.95  
1956 Left, before 4-30-56 (2) ..... B6S-4050553-A 47.95  
56-57 Right, from 5-1-56 (3) ..... B6S-4050552-B 47.95  
56-57 Left, from 5-1-56 (3) ..... B6S-4050553-B 47.95

## Rear Deck Plate Gaskets



55-57 For hard & soft tops ..... B5S-4050534-PR 1.95 pair

## Rear Hold-Down Clamp Retaining Plates



55-57 Right ..... B5S-4050608-A 27.95  
55-57 Left ..... B5S-4050609-A 27.95

## Tacking Strip for Hard Top



55-57  Tacking strip for hard top... B5S-4051278-B 14.95

*If you are thinking about replacing the seals on your hardtop, take a look at our complete listing in the Weatherstripping. From an individual seal to a whole 7-piece kit, we have what you need!*

## Top Rear Fasteners (2 required)



1955 Bullet shape with two pins ..... B5S-4050590-A 16.95  
1956 Before 4-30-56 ..... B6S-4050590-A 16.95  
56-57 Bullet shaped with one pin, from 5-1-56 ..... B6S-4050590-B 16.95

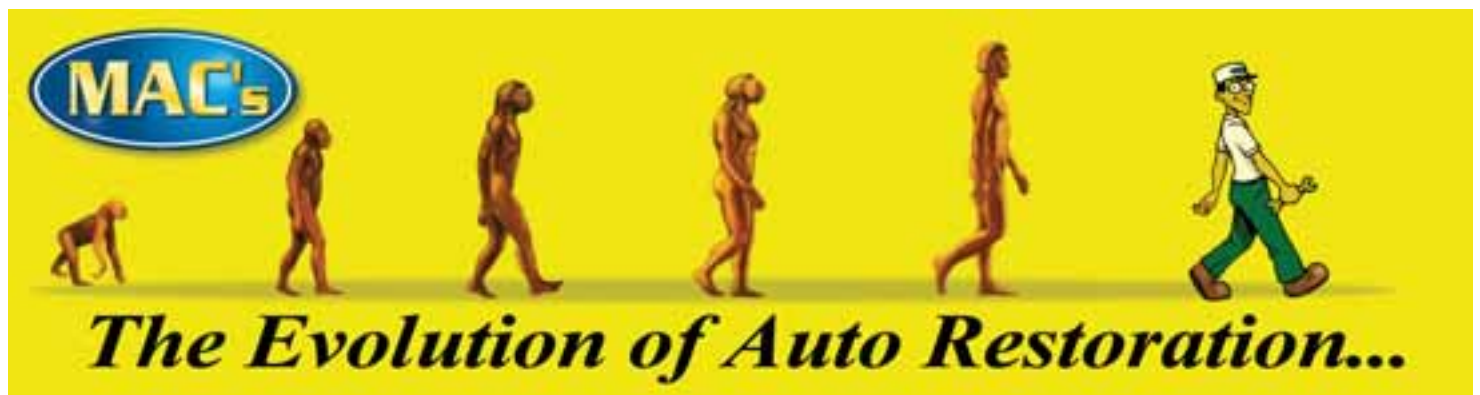



## Trunk Mats



Unsure of the color?  
Order **SAMPLE4**,  
it's free!

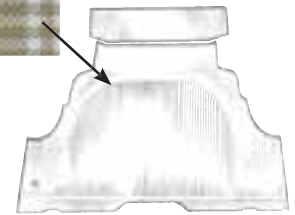
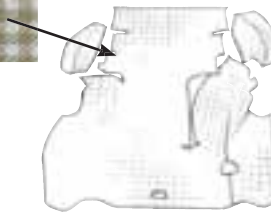
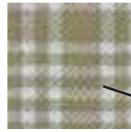

1955	Rubber, <b>limited availability</b> .....	B5S-4045456-R	130.95
1956	Rubber, includes hanging curtain .....	B6S-4045456-R	149.95
1956	Plaid Burtex type will also fit 1955, but it is not correct, includes hanging curtain .....	B6S-4045456-B	58.95
1957	Plaid Burtex type, includes 2 wheelhouse covers & hanging curtain .....	B7S-4045456-B	76.95

## Trunk Lock Parts



1957	Trunk lid handle, chrome, use with plastic insert .....	B7S-4043500-A	31.95
1957	Spacer, for trunk lock .....	B7S-4043565-A	7.95



1957	Lock release rod .....	B7S-4043226-A	3.95
------	------------------------	---------------	------



55-57	Cylinder & keys, keyhole cover is not included. ....	B9A-6443505-A	36.95
55-57	<b>NEW</b> Trunk lock cylinder, with 2 reproduction Ford keys, keyhole cover is not included. ....	B9A-6443505-AF	41.95
55-56	Keyhole cover .....	B5A-7043516-A	14.95
1957	Keyhole cover .....	B5A-7343516-A	15.95



55-56	Lock cylinder housing, keyhole cover included .....	B5S-4043603-B	36.95
1957	Lock cylinder housing, keyhole cover included .....	B5A-7043603-BR	38.95



55-57	Nut, for lock cylinder housing .....	356164-S8	1.95
55-56	Lock housing pad .....	B5S-4043625-A	4.95
1957	Lock housing pad .....	B5A-7043625-B	3.95

## Trunk Lid Handle Parts

55-56	Spring, for flipper on lock .....	B5S-4022007	2.95
-------	-----------------------------------	-------------	------



1957	Insert, plastic nameplate, for trunk lid handle .....	B7S-4042530-A	16.95
1957	Spring, for flipper on lock .....	B7S-4022007	1.95

## Trunk Lid Weatherstrip

55-57	168" long .....	B5S-4043720-A	16.95
-------	-----------------	---------------	-------

*We suggest RSP89 adhesive to attach weatherstripping.*



ALL	Weatherstrip adhesive, yellow, 5 oz. tube, for spongy type seals like the trunk .....	RSP89	7.95
-----	---------------------------------------------------------------------------------------	-------	------

## Trunk Side Boards



1955	Left, as original .....	B5S-4045415-A	4.95
------	-------------------------	---------------	------



1956	Right & left. ....	B6S-4045415-PR	9.95 pair
1957	Left is the trunk side, right is a floor extension .....	B7S-4045415-ST	9.95 set

## Trunk Divider Panels



1955	Fits behind seats, die-cut, painted gray with jack instructions sheet installed. . .	B5S-4045444-AR	18.95
1955	<b>NEW</b> Fits behind seats, die-cut, unpainted. ....	B5S-4045444-A	11.95



Trunk Lid Bumpers



- 55-56 Trunk lid bumpers . . . . . B7A-13398-PR 8.95 pair
- 1957 Trunk lid bumpers . . . . . B7S-13398-PR 3.95 pair

Trunk Hinge Springs (2 required)

- 55-56 Trunk hinge spring . . . . . B5S-42701 16.95
- 1957 Trunk hinge spring . . . . . B7S-42701 7.95

Gas Door Springs



- 55-56 Gas door spring . . . . . B5S-16377-A 4.95
- 1957 Gas door spring . . . . . B7S-16377-A 4.95

Gas Door Emblem Insert & Bezel



- 55-56 Emblem insert, plastic . . . . . BM-7325662-B 28.95



- 55-56 Emblem bezel, Ford crest, chrome . . . . . B5S-4025666-A 22.95

Gas Tank Filler Door Hinges & Bumpers



- 55-56 Gas tank filler door hinge . . . . . B5S-4040635-A 47.95
- 1957 Gas tank filler door hinge . . . . . B7S-4040635-A 47.95



- 55-56 Gas tank filler door bumpers . . . . . 357170-APR 3.95 pair
- 1957 Gas tank filler door bumpers . . . . . 357170-BPR 3.95 pair

Spare Wheel Clamp



- 1955 . . . . . C5ZZ-1424-A 3.95

Spare Wheel "J" Hooks



- 1955 Replacement type . . . . . B5A-1448-B 4.95
- 1955 Exact reproduction of the original . . . . . B5S-1448 8.95

Spare Wheel Wing Nuts



- 1955 Replacement type . . . . . B9AZ-1462-A 2.95



- 1955 Original size & shape . . . . . B2AZ-1462-A 15.95
- 1957 Replacement type . . . . . B9AZ-1462-A 2.95
- 1957 Original size & shape . . . . . B2AZ-1462-A 15.95

Spare Wheel Hold Down Brackets



- 1955 Spare wheel bolt bracket, this welds to the trunk floor . . . . . B5S-11215-B 9.95
- 1955 Spare wheel support, this welds to the trunk floor . . . . . B5S-11215-C 7.95



- 55-56 Jack strap retainer bracket, this welds to the trunk floor . . . . . B5S-11215-D 3.95
- 55-57 Jack post bracket, this welds to the wheelhouse . . . . . B5S-11215-E 1.95
- 1957 Jack strap retainer bracket, this welds to the trunk floor . . . . . B7S-11215-D 3.95



- 1957 Spare wheel mounting plate . . . . . B7S-1424-A 36.95

Wheel Cover Tool

This tool is a must have for removing the wheel cover from the continental kit.

- 1956 . . . . . B5S-1132 10.95 kit

Jack Strap



- 55-57 Jack hold-down strap . . . . . B5A-17083-A 17.95





**USA-1**

**AM/FM Cassette Stereo Radio**

Our "standard" radio has more than just "standard" features. With 200 watts of power, a chrome nosepiece & reproduction knobs.

Get today's sound out of your original dash!  
Standard features include:



- Electronic Tuning
- Auto Reverse
- 30 Station Presets (12 AM, 18 FM)
- Preset Memory Scan
- Digital Clock
- Power Antenna Lead
- Dual RCA Pre-out
- Front To Rear Fader
- Fast Forward & Rewind
- Seek & Scan
- Separate Bass & Treble
- Left & Right Balance Control

55-57 B5S-18806-CA1 . . . . 222.95

**Best Of All, They Fit Your Factory Original Dash Opening!**

**USA-5**

**AM/FM Cassette Stereo Radio**

This radio is equipped with all the features of the USA-1, plus 240 (4 x 60) watts of power. You also get 6 more station presets, a CD changer control & metal tape capability.

55-57 B5S-18806-CA5 . . . . 302.95



**IMPORTANT INSTALLATION INFORMATION:**

All stereo equipment on this page requires a 12 volt negative ground. All 1955 stereo equipment installation needs a 6 volt positive ground system. Use of any other ground will destroy the radio. All of these radios are engineered to fit the original dash opening with no cutting, grinding or snipping; in fact, no modifications at all. All brackets, wiring & plugs, mounting hardware, a chrome bezel & original-looking chrome knobs along with installation instructions complete the package. All of our radios carry the manufacturer's 12-month limited warranty.

*Its standard features include:*

- \* 16 bit twin D/A converter
- \* 3 beam laser tracking
- \* 8x oversampling digital filter
- \* Advanced anti-vibration system
- \* Includes 16' of cable & all required mounting accessories

**PLAY CD'S IN YOUR CLASSIC CAR!**



This 10-disc CD/CDR & CD-RW changer fits easily under your seat or in the trunk (11-3/8" wide x 2-7/8" high x 7-5/8" deep). It can be mounted horizontally or vertically. It's a simple one cable hook-up to a USA-5 & the radio controls all of the functions of the CD changer.

ALL USA-CD10 . . . . . 318.95

**\$UPER \$AVER    \$UPER \$AVER    \$UPER \$AVER**

Our USA-CD10 10-disc changer plus any of our USA-5 model radios.

ALL USA-5PK . . . . . 549.95



This SA-2 model is perfect for the show enthusiast. It allows you to leave the original radio in the dash & still get digital quality sound at the touch of a button. The main receiver is hidden under the seat, or wherever you choose to put it, while the remote controlled LCD screen is flush-mounted or swivel-mounted (optional) out of sight. Being only 3/4" thick allows you to mount it almost anywhere, such as the glove box, ashtray, sun visor or console.

## SECRET AUDIO

The SA-2 (140 watts, with radio frequency remote control) features: AM, FM stereo; 4-way fader; separate bass & treble; seek & scan tuning; flush remote mounted LCD bezel; optional swivel mount for LC control unit; dual RCA pre-out; 12 AM, 18 FM pre-set stations; CD changer (not included) controlled by wireless remote (not included) or remote mounted LCD panel.



**SA-2**

55-57 SA-2, includes flip-phone style remote. . . . .254.95

### Dual Front Speaker Assemblies

Since you don't want to cut holes in your doors or kick panels for speakers, we have the perfect solution: two speakers mounted to a bracket that will drop into your original dash speaker opening with no modifications at all! These assemblies are pre-wired to "plug-in" instantly to our radios. Want the best possible sound from your original speaker location? Upgrade to our dual voice coil speakers. They have 70% more cone area than our standard speakers & that gets you better bass response & 140-watt power handling capability. Each speaker has dual tweeters for crisp clear highs to make your favorite radio sound like it should. Give us a call & step up to dual voice coil speakers today.

### Dual Front Speaker Assemblies



55-57 18808-1006 . . . . . 34.95

### Dual Voice Coil Speaker Assemblies

55-57 18808-3006 . . . . . 47.95

### Undercover Stealthspeakers

For those who want the deepest full bass sound, upgrade to our new Stealthspeaker 2. Able to handle up to 200 watts, these speakers utilize the same Piezo tweeter as the original Stealthspeaker for their clean & crisp highs, but now there are 2 in each enclosure. Add to that a larger 8" woofer & your favorite music will now be heard with an amazing new clarity & definition. If you want the best sound from a portable speaker, Stealthspeaker 2 is for you. Call & place your order today!

- ALL **NEW** Stealthspeaker 2,  
11" wide x 12.5" deep  
x 2.95" high . . . . .18808-6000 142.95 pair
- ALL **NEW** Stealthspeaker,  
11" wide x 8" deep  
x 2.875" high . . . . .18808-5000 119.95 pair



### Dynamat® Sound Insulation

For years, we have been selling the original Dynamat & can boast hundreds of satisfied customers. We are now proud to offer the next generation of Dynamat sound deadeners: Xtreme. Xtreme is a step up from the original formula & is Dynamat's best product at controlling vibration. It damps 4 times as much as the original Dynamat &, as an added bonus, it weighs 50% less. It is available in conveniently sized 18" x 32" sheets & with peel & stick application; it goes on quickly & easily. Do yourself a favor & order some today!

ALL **NEW** Dynamat® Xtreme, each piece is  
18" x 32" (as required) . . DYNAMAT-0433 29.95





## Radio Knobs *(as required)*

- 55-57 Radio knob, black with chrome, split shaft, 1955-1956 used 2 knobs, 1957 used 1 knob this style . . . . . 18829-S 23.95
- 55-57 Nut, special thin nut for factory radio shaft . . . . . B5S-18810 1.95



- 1957 Radio knob, black with chrome, D-shaft . . 18829-D 16.95

## Radio Antennas



- 55-57 Radio antenna, exact reproduction, front mount . . . . . B5S-18813-A 60.95



- 55-57 Radio antenna, front mount, complete with lead-in wire from antenna to radio . . . . . B5A-18813-C 69.95



- 1957 Radio antenna, rear mount, complete with lead-in wire from antenna to radio, includes instructions & template . . . . . B7A-18813-A 88.95

## Antenna Parts



- 55-57 Antenna mounting pad, front mount . . BA-18818-F 6.95



- 55-57 Grommet, for lead-in wire. . . . B5A-18912-A 3.95



- 1957 Antenna mounting pad, rear mount. . . . . B7A-18818-T 6.95



- 55-57 Antenna base, black plastic . . . . . 18813-BASE 11.95





# WHEEL COVERS & HUB CAPS

## Wheelcovers (4 required)

Your Thunderbird will instantly look better when you put our new wheel covers on it. The details are all there: the center emblem on the '55 & '56 full wheel cover has the correct red background with an accurately reproduced, beautifully rendered, Ford crest encased in plastic just like the original. In fact, it's currently being produced on the original Ford dies! The '57 wheel cover has the same attention to detail, as the painted center section is white & the embossments are trimmed in black just like they were in 1957. Both the '55 & '56 hub caps have properly painted backgrounds in red & white, respectively. Whatever your Little Bird requires, we have it here at MAC's.



- 55-56 15-1/8" diameter, includes center medallion . . . . . B5A-1130-C 76.95
- 1957 14" diameter, 38 embossments. . . . . B7A-1130-B 83.95

## Hub Caps (4 required)



- 55-56  Hub cap, 10-1/4" diameter, plain background in center . . . . . B5A-1130-P 42.95



- 1955 10-1/4" diameter, red in center . . . . . B5A-1130-D 47.95



- 1956 10-1/4" diameter, white in center. . . . . B6A-1130-A 47.95

## Wire Wheel Cover Sets



**\$UPER \$AVER \$UPER \$AVER**  
Save **BIG BUCKS** when you buy our kits!

- 1955 Set of 4, with bright center caps with red painted accent. . . . . B5S-1130-ST4 550.95 set
- 1955 Set of 5, with bright center caps with red painted accent. . . . . B5S-1130-ST5 685.95 set
- 1956 Set of 4, with bright center caps with white painted accent. . . . . B6S-1130-ST4 550.95 set
- 1956 Set of 5, with bright center caps with white painted accent. . . . . B6S-1130-ST5 685.95 set

## Wire Wheel Cover Parts



- 55-56 Clip for attaching simulated wire wheel covers (20 required) . . . . . B5A-1150-A 4.95



- 55-56 Rubber bumper, attaches to above clip (20 required) . . . . . B5A-1151-A 0.95

## Wheel Cover Medallion



- 55-56 Wheel cover medallion, Ford crest with red background, 2-1/16" diameter, not including tabs, (4 required). . . . . B5A-1141-A 24.95



## Continental Kit Parts

1956	Stone guard, fiberglass, seals not included, listed below (1) . . . . .	B6S-1352-A	96.95	1956	Spring, for hinge latch (5) . . . . .	B6S-1473	7.95
1956	Seal set, 4 pieces, for stone guard, includes upper, lower & 2 curved pieces for the lower sides (2) . . . . .	B6S-1352-ST	18.95 set	1956	Tire cover, with rubber bead around the outside edge to protect the paint as original (2 required) (6) . . . . .	B6S-1406-A	88.95
1956	Grommet set, 2 pieces, for hinge, rubber (3) . . . . .	B6S-1354-ST	10.95 set	1956	Hinge lever assembly (7) . . . . .	B5S-1386	125.95
1956	Bumper, for hinge latch, rubber (4) . . . . .	B6S-1455	4.95	1956	Hinge & mounts (8) . . . . .	B6S-1481-C	129.95
				1956	Pivot bolt for hinge (9) . . . . .	B6S-1487-A	9.95
				1956	Spring, for lever assembly (10) . . . . .	B6S-16921	3.95

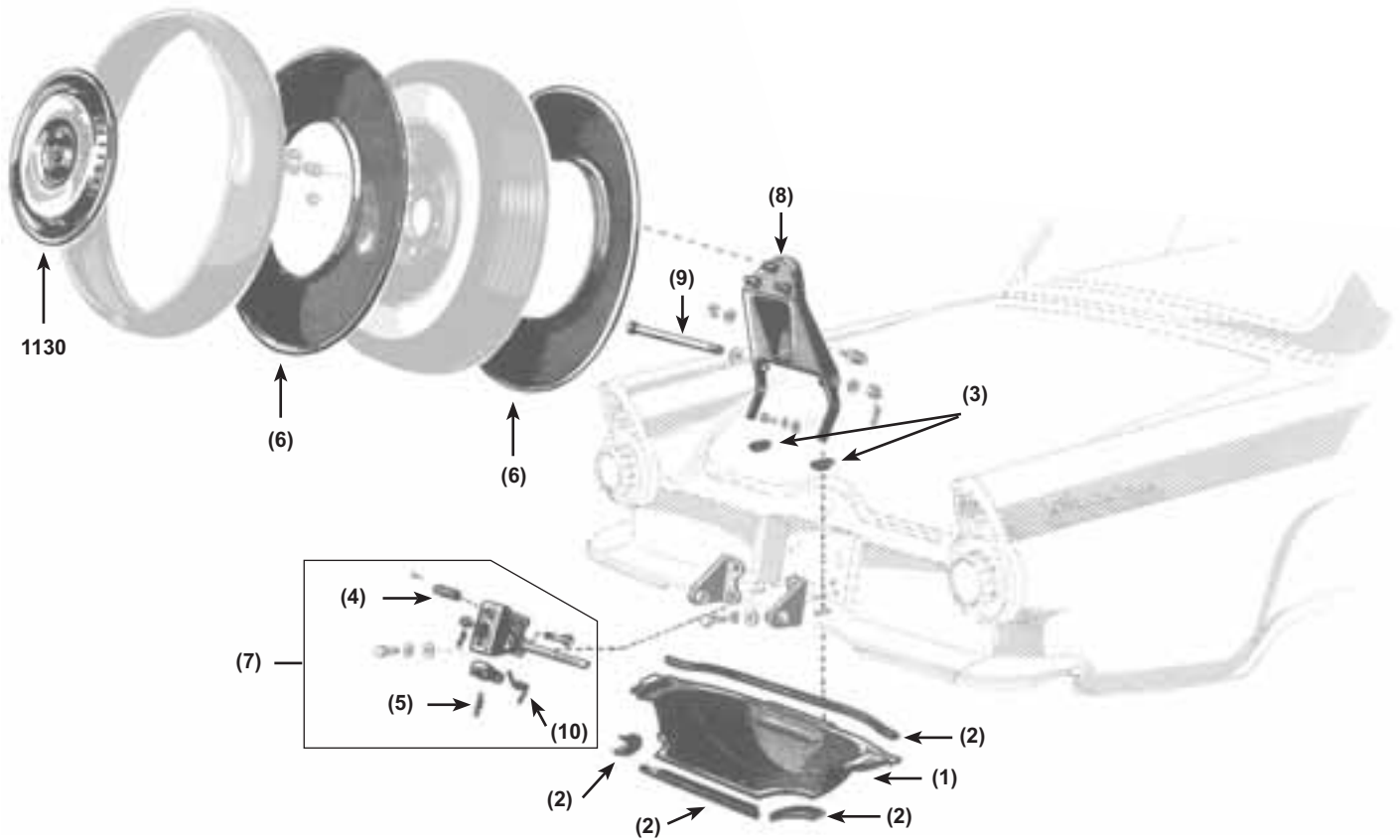



Before you install those new brake shoes, you should check the condition of the grease seals & wheel bearings! MAC's carries front & rear axle seals & bearings for your T-bird.

**Brake Overhaul Kits**

Now that you've gotten your car running, you need to make sure you can make it stop! MAC's makes this easy with our new brake overhaul kits. We pack everything you'll need\* to completely renew your brakes, front & rear, into one convenient kit.

**\$UPER \$AVER \$UPER \$AVER**  
You save more than \$100.00 when you buy these kits!

These money saving kits include:

- Front & rear shoes
- Return spring kits
- Horseshoe locks
- Brake shoe adjusters
- Front & rear brake hoses & their copper washers
- Hold down springs
- Front & rear wheel cylinders
- Rubber plugs

\* Brake drums are not included in kits.

All kits carry a \$60.00 core fee for the front & rear brake shoes. The fee will be refunded when you return your old shoes within 90 days of purchase. Remember that the cores must be returned in the same boxes they were sent in.

1955	Complete brake overhaul kit . . . . .	B5S-2001-KT	250.95 kit
1956	Complete brake overhaul kit . . . . .	B6S-2001-KT	250.95 kit
1957	Complete brake overhaul kit . . . . .	B7S-2001-KT	250.95 kit

**Wheel Lug Nut & Stud (20 required)**



55-57	Lug nut, 1/2"-20, zinc plated . . . . .	B-1012	0.50
55-57	Wheel stud, 1/2"-20 x 1-1/2" long . . . . .	C1AZ-1107-A	1.95



**Front Brake Drums (2 required)**



55-56	Front brake drum . . . . .	B5A-1125	100.95
1957	Front brake drum . . . . .	B7S-1102-A	107.95

**Front Hub Grease Cap & Tool**



55-57	 Grease cap, 1-25/32" ID (2 required) . . . . .	B5A-1131-A	5.95
ALL	 Grease cap tool, perfect for installing your grease caps . . . . .	TOOL-1131	11.95

**Front Brake Grease Baffle Gasket (2 required)**



55-56	Front brake grease baffle to backing plate gasket . . . . .	B4A-1193-A	1.95
-------	-------------------------------------------------------------	------------	------

**Front Grease Seal (2 required)**



55-57	Front grease seal . . . . .	B5AZ-1190-A	4.95
-------	-----------------------------	-------------	------

**Front Spindle Washer (2 required)**



55-57	Front spindle washer . . . . .	C2AZ-1195-A	8.95
-------	--------------------------------	-------------	------

**Rear Brake Drums (2 required)**

55-56	Rear brake drum . . . . .	B5A-1126-B	104.95
1957	Rear brake drum . . . . .	B7S-1126-A	107.95

**Rear Axle Flange Gasket (4 required)**



55-57	2 per side . . . . .	A8AZ-1001-B	1.95
-------	----------------------	-------------	------

**Rear Axle Grease Seal (2 required)**

55-57	1-1/2" ID x 2-1/2" OD . . . . .	B7A-1177-A	4.95
-------	---------------------------------	------------	------

**Wheel Bearing Sets**



55-57	Inner front wheel bearing set (2 sets required) . . . . .	B5A-1201-ST	15.95 set
55-57	Outer front wheel bearing set (2 sets required) . . . . .	B5A-1216-ST	15.95 set
55-57	Rear wheel bearing, stamped 88128, 1-17/32" ID x 3-5/32" OD (2 required) . . . . .	C1SZ-1225-B	29.95

**Grease**

Premium Timken brand wheel grease in a 1 lb. tub with special additives to prevent rust & reduce wear. A must have for installing new bearings, cups & grease caps!



ALL	1 lb. container . . . . .	GREASE	5.50
-----	---------------------------	--------	------

**Bearing Grease Packer Kit**

Applies fresh grease evenly to virtually any bearing. The old grease is forced out onto the cone for easy clean up.



ALL	 Universal, 4-1/2" diameter cone . . . . .	X6150	9.50 kit
-----	--------------------------------------------------------------------------------------------------------------------------------	-------	----------

**Seal Puller**

Use on any oil or grease seal. Place the tip behind the seal, press & pull.



ALL	 Universal, two tip sizes fit almost all applications . . . . .	X1175	9.50
-----	-----------------------------------------------------------------------------------------------------------------------------------------------------	-------	------





## Brake Shoe Sets

### Relined Brake Shoe Sets

Always measure your drum diameter & brake shoe width to make sure you get the correct set of shoes.

#### CORE EXCHANGE

**NOTE:** The relined brake shoes below are sold on an exchange basis. A core fee of \$30.00 will be charged if your core is not received before we ship. Core fee will be refunded if an acceptable exchange is received in the supplier's original package within 90 days of purchase.



55-56	Front, 11-1/32" x 2-1/4" . . . . .	C5AZ-2200-ST	34.95 set
1957	Front, 11-1/32" x 2-1/2" . . . . .	C3AZ-2001-ST	34.95 set
55-56	Rear, 11" x 1-3/4" . . . . .	B5S-2200-ST	34.95 set
1957	Rear, 11" x 2" . . . . .	B8S-2200-ST	34.95 set

## Brake Shoe Parts

### Brake Shoe Return Springs (4 required)



55-57	Front, 5" long . . . . .	B5A-2035-A	2.95
55-56	Rear, 5" long . . . . .	B5A-2035-A	2.95

### Brake Shoe Adjuster Assembly (4 required)



55-57	Right or left, front or rear. . . . .	B5A-2041-A	9.95
-------	---------------------------------------	------------	------

### Brake Shoe to Cylinder Link (8 required)



55-57	Front or rear . . . . .	B7A-2042-A	4.95
-------	-------------------------	------------	------

### Brake Shoe Adjusting Springs (2 required)



55-57	Front or rear . . . . .	H-2049	2.95
-------	-------------------------	--------	------

### Brake Shoe Hold-Down Kits



55-57	Front axle . . . . .	B5A-2068-KT	9.95 kit
-------	----------------------	-------------	----------



55-56	Rear axle . . . . .	B2A-2068-KT	9.95 kit
1957	Rear axle . . . . .	A9A-2068-KT	9.95 kit



### Brake Adjustment Hole Plug (as required)



55-57	Rubber. . . . .	8A-2092	0.95
-------	-----------------	---------	------

### Emergency Brake Link (2 required)



55-57	Link, from emergency brake lever to primary brake shoe . . . . .	COAA-2A642-A	20.95
-------	------------------------------------------------------------------	--------------	-------

## Brake "C" Clip (Horseshoe Lock) & Washer (2 required)



55-57	"C" clip (horseshoe lock), rear parking brake lever . . . . .	91A-2106	0.75
55-57	"C" clip anti-rattle washer, Genuine Ford . . . . .	351467-S	1.95

## Pedal Pads

### Brake



55-57	Automatic transmission, without "Swift Sure" script listed below . . . . .	B5S-2454-P	28.95
55-57	<b>NEW</b> Stainless steel band, with "SWIFT SURE FORD POWER BRAKES" stamped into it, fits pedal B5S-2454-P above. . . . .	B5S-2454-SS	19.95



55-57	Automatic transmission, manual brakes. . . . .	AB-2454-B	14.95
55-57	Automatic transmission, power brakes. . . . .	B9A-2454-B	28.95

### Brake & Clutch



55-56	Manual transmission . . . . .	B2A-2457-A	12.95
1957	Manual transmission, correct for 1957, factory replacement for 55-56 (2 required) . . . . .	B7A-2457-A	4.95

## Brake Pedal Arm Spring Bushing & Bumper

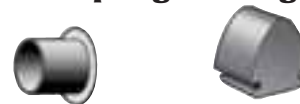

55-57	Nylon . . . . .	B5A-2481-A	22.95
55-57	Rubber, replacement type, also used on the clutch pedal. . . . .	MA-7583-A	2.95

## Brake Pedal Arm Pivot Bushing



55-57	Nylon . . . . .	AB-2461-B	12.95
-------	-----------------	-----------	-------

## Brake Light Switch



55-57	Brake light switch . . . . .	C1AZ-13480-A	7.95
-------	------------------------------	--------------	------



**Master Cylinder & Parts**

**Master Cylinder**



55-57 1" bore, this is a new master cylinder . . . B5A-2140-B 69.95

**Master Cylinder Rebuild Kit**

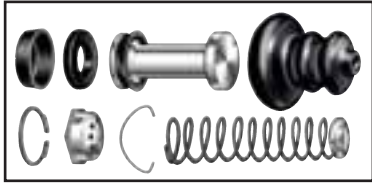

55-57 1" diameter bore . . . . . B5A-2004-KT 16.95 kit

**Master Cylinder Filler Caps & Gasket**

55-56 Filler cap, Concours correct "FoMoCo" logo, includes gasket, used from '55 thru early '56 . . . . . B5S-2162 44.95

56-57 Filler cap, Concours correct BB marking, includes gasket, used late '56 thru '57 . . . . . B6S-2162 40.95



55-57 Master cylinder filler cap gasket . . . . . 8M-2167 1.95

55-57 Master cylinder filler cap, replacement type. . . . . AB-2162-CR 9.95

**Master Cylinder Outlet Fitting & Bolt**



55-57 Master cylinder outlet fitting . . . . . AB-2076-A 8.95



55-57 Master cylinder outlet fitting bolt . . . . . 91T-2276 9.95

**Master Cylinder Link Rod Bolt**



55-57 Offset thread, **Genuine Ford** . . . . . COTT-2462-A 17.95

**Master Cylinder Pushrod Bushing (2 required)**



55-57 Bushing . . . . . B2A-2474-A 5.95

**Brake Hoses**



55-57 Front brake hose, right or left, 14-3/8" long (2 required) . . . . . B4AZ-2078-A 19.95

55-57 Rear brake hose . . . . . B2AZ-2282-B 19.95

1957 Bracket, on frame for rear brake hose (not shown) . . . . . B7S-2073 10.95

**Hose Retainer Clip (3 required)**



55-57 2 from hose to connector in the front & 1 for the rear hose to the frame . . . . . 78-2814 0.95

**Brake Line Gasket (as required)**



55-57 Copper, 0.51" ID x 0.70" OD. . . . . 91T-2154 0.70

**Brake Line Kits**

*One kit does one vehicle, rubber brake hoses not included: see #B4AZ-2078-A & B2AZ-2282-B listed above.*

- 1955 Manual brakes, OE steel . . . . . B5S-2269-AKT 134.95 kit
- 1955 Power brakes, OE steel . . . . . B5S-2269-BKT 134.95 kit
- 1956 Power brakes, OE steel . . . . . B6S-2269-BKT 134.95 kit
- 1957 Manual brakes, OE steel . . . . . B7S-2269-AKT 134.95 kit
- 1957 Power brakes, OE steel . . . . . B7S-2269-BKT 134.95 kit
- 1955 Manual brakes, stainless steel . . . . . B5S-2269-MSS 248.95 kit
- 1955 Power brakes, stainless steel . . . . . B5S-2269-PSS 248.95 kit
- 1956 Power brakes, stainless steel . . . . . B6S-2269-PSS 248.95 kit
- 1957 Manual brakes, stainless steel . . . . . B7S-2269-MSS 248.95 kit
- 1957 Power brakes, stainless steel . . . . . B7S-2269-PSS 248.95 kit

**Brake Line Connectors & Parts**

55-56 Connector block, for rear lines . . . . . B5S-2074 60.95



1957 Connector block, for rear lines . . . . . 8A-2074 9.95

55-56 Bracket, for B5S-2074 connector block . . . . . B5S-2074-BRKT 8.95

55-57 Connector block, for lines at left front . . . . . B5S-2075 15.95

55-57 Copper gasket, for connector block . . . . . 8M-2149 1.95



55-57 Copper gasket, for above connector block (2 required) (shown) . . . . . 91T-2154 0.70

55-57 Bolt, for above connector block. . . . . 8M-2150 5.95

55-57 Connector block, for 3 brake lines & brake light switch . . . . . 354446-S 65.95

55-57 Clip, for brake lines, 1 at frame & 2 at rear axle (3 required) . . . . . B4A-2244-A 1.95

55-57 Screw, for above brake line clip (3 required) . . . . . 31519-S 1.95



**Front Brake Wheel Cylinders**



55-57 Right, 1-1/8" bore .....AD-2061-A 32.95



55-57 Left, 1-1/8" bore .....AD-2062-A 32.95

**Rear Brake Wheel Cylinders**



1955 Right, 7/8" bore .....C3AZ-2261-B 24.95



1955 Left, 7/8" bore .....C3AZ-2262-B 24.95



56-57 Right, 15/16" bore .....B7A-2261-A 24.95



56-57 Left, 15/16" bore .....B7A-2262-A 24.95

**Wheel Cylinder Rebuild Kits (2 required)**

55-57 Front, for 1-1/8" diameter cylinder. .... 8M-2221 12.95 kit

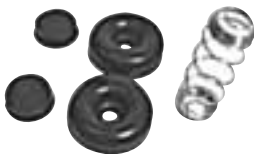

1955 Rear, for 7/8" diameter cylinder. .... 8A-2128 5.95 kit

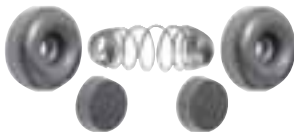

56-57 Rear, for 15/16" diameter cylinder. ....B2A-2128 12.95 kit

**Wheel Cylinder Bleeder Screw (4 required)**



55-57 Front or rear ..... 8M-2208 1.95

**Power Brake Boosters & Parts**

**Rebuilt Booster**

Please allow 3 to 4 weeks for rebuilding after we receive your rebuildable unit.

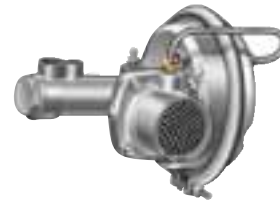

55-57 Power brake booster ..... PB40151 199.95

**New Booster**

55-57 Does not include the check valve ..... PB40151N 395.95

**Check Valve**



55-57 Brass ..... B4A-2365-A 22.95

**Outlet Connector Block**

55-57 Brass ..... B5S-2076 10.95

**Power Brake Booster Mounting Brackets**

1955 Power brake booster mounting bracket. .... B5S-2031-A 48.95

56-57 Power brake booster mounting bracket. .... B6S-2031-A 48.95

**Power Brake Booster Flex Hose**

55-56 From booster to frame connector ... B5SZ-2078-A 24.95

**Power Brake Booster "C" lines**



55-57 Steel replacement ..... B5S-2420-A 14.95

55-57 Stainless steel replacement ..... B5S-2420-S 15.95

55-57 Stainless steel with inline vacuum restrictor. .... B5S-2420-ARS 20.95

**Power Brake Booster Vacuum Lines & Hose**

1955 Power brake booster vacuum line. .... B5S-2369-A 23.95

1956 Power brake booster vacuum line. .... B6S-2369-A 23.95

1957 Power brake booster vacuum line, except "E" & "F" Bird ..... B7S-2369-A 23.95

**Vacuum Line & Hose**

1957 Vacuum line, for "E" Bird with two 4 bbl carbs. .... B7S-2369-E 3.95

1957 Vacuum line, for "F" Bird with supercharger ..... B7S-2369-F 4.95

55-57 Clamp, for rubber hose from booster to metal vacuum line, with correct style screw (2 required) ..... B5A-2344-A 1.95

55-57 Booster to vacuum line hose, rubber, cut to fit. .... B5S-2249-A 5.95

**Air Filter**

55-57 Air filter for booster control valve inlet, foam ..... AD-2386-A 1.95

**Breather Screen**

55-57 Breather screen for booster, plated. ... AD-2421-A 6.95





**Emergency Brake Parts**

**Brake Shoe "C" clips (Horseshoe Locks) (2 required)**



- 55-57 Brake shoe "C" clip (horseshoe lock) . . . 91A-2106 0.75
- 55-57 Brake shoe "C" clip anti-rattle washer,  
**Genuine Ford** . . . . . 351467-S 1.95

**Emergency Brake Link Spring (2 required)**



- 55-57 Emergency brake link spring. . . . .A8TZ-2A601-A 5.95

**Emergency Brake Equalizer Rod**



- 55-57 Universal, 12" long, customer must cut to required length, from threaded end. . . . .B7A-2628-B 13.95

**Emergency Brake Release Handle**



- 55-57 Chrome . . . . .B5S-2780-B 73.95

**Emergency Brake Ratchet Spring**



- 55-56 . . . . . 0M-2788 2.95

**Emergency Brake Cable Clip (3 required)**



- 55-57 Also fits cable to frame & cable to front bracket . . . . . 8M-2814 2.95

**Front Emergency Brake Cable**

- 55-57 Stainless steel, 55-1/2" long . . . . .B5S-2853-A 36.95

**Rear Emergency Brake Cables (2 required)**

- 55-56 110" long . . . . .B5S-2A635-A 36.95
- 1957 100" long . . . . .B7S-2A635-A 36.95

**Miscellaneous Emergency Brake Parts**



- 55-57 Emergency brake equalizer lever nut . . . . .8A-2091 5.95



- 55-57 Emergency brake cable pulley (shown left) . . . . . 0M-2804 23.95
- 55-56 Pawl, for emergency brake ratchet . . . . . 0M-2786 7.95
- 55-57 Lever, for emergency brake equalizer . . . . . B5S-2A605 15.95
- 55-57 Knurled pin, for emergency brake ratchet (shown right) . . . . . 0M-2859 3.95



- 55-57  Clip, for emergency brake pulley cover . . . . . B5S-2805-CLIP 6.95



# TIRES



All tires are oversized & require additional shipping charges, even if shipped to our store.

### 15" Whitewall Tires (Tubeless) (4 required)

55-56	6.70 x 15", 2-1/2", BF Goodrich	15WBB	149.95
55-56	6.70 x 15", 2-3/4", BF Goodrich	15WBD	347.95
55-56	6.70 x 15", 2-3/4", Coker Classic	15WCA	139.95
55-56	6.70 x 15", 2-1/2", US Royal	15WYB	160.95
55-56	6.70 x 15", 2-11/16", US Royal	15WYC	160.95
55-56	6.70 x 15", 2-11/16", Firestone	15WFC	153.95
55-56	6.70 x 15", 2-11/16", Universal	15WUB	129.95
55-56	6.70 x 15", 2-11/16", Goodyear Deluxe Super Cushion	15WGB	184.95

### 15" Blackwall Tires (Tubeless) (4 required)

55-56	6.70 x 15", BF Goodrich	15BBA	136.95
55-56	6.70 x 15", Goodyear Custom Super Cushion	15BGA	160.95
55-56	6.70 x 15", Firestone	15BFA	136.95

### 14" Whitewall Tires (Tubeless) (4 required)

1957	7.50 x 14", 2-1/4", Goodyear Custom Super Cushion	14WGC	176.95
1957	7.50 x 14", 2-1/4", BF Goodrich	14WBH	150.95
1957	7.50 x 14", 2-1/4", Coker Classic	14WCA	132.95
1957	7.50 x 14", 2-1/4", US Royal	14WYF	158.95
1957	7.50 x 14", 2-3/8", Firestone	14WFA	150.95
1957	7.50 x 14", 2-1/4", Universal	14WUB	123.95



Blackwall tires were standard equipment for 1955-1957.  
 1955: 6.70 x 15" on 5" wide rim  
 1956: 6.70 x 15" on 5" wide rim  
 1957: 7.50 x 14" on 5" wide rim, 2-1/8" wide whitewall



### TIRE SHIPPING NOTE

If tires must be shipped to MAC's, there will be an additional charge of \$15.00 per tire to cover shipping expenses. This applies to any Alaska, Hawaii, Puerto Rico, Foreign, C.O.D., or walk-in order. There will be no exceptions.

# STEERING

### Outer Tie Rod (2 required)

Don't forget to fully grease tie rods after installing them.



55-57	Right or left	11A-3271	13.75
-------	---------------	----------	-------

### Inner Tie Rods

1955	Right or left (2 required)	B5S-3280-A	90.95
56-57	Right	B6S-3280-A	60.95
56-57	Left	B6S-3281-A	60.95

### Tie Rod Connecting Sleeve (2 required)



55-57	Right or left	11A-3310	9.95
-------	---------------	----------	------

### Tie Rod End Cups



55-57	Original type (4 required)	B4A-3332-A	2.95
55-57	4-piece set, rubber cups for the top of the ball joints	B4A-3332-ST	4.95 set

### Idler Arm Bushings



55-57	Idler arm bushing, manual steering (2 required)	MB-3356-A	4.95
55-57	Power steering, upper	MA-3356-B	11.95
55-57	Power steering, lower	MA-3358-A	8.95
55-57	Seal, for idler arm bushings, with manual steering (2 required)	8M-3359	1.95

### Idler Arms



55-57	Idler arm, power steering (shown)	B5S-3352-B	51.95
55-57	Idler arm, manual steering	B5S-3352-C	51.95
55-57	Crush nut, idler arm bracket to frame, power steering	B5S-3A351	2.95
55-57	Crush nut kit, idler arm bracket to frame, power steering, includes crush nut, bolt, nut & washer plus instructions	B5S-3A351-KT	3.95 kit
55-57	Idler arm bracket, power steering	B5S-3351-A	110.95
55-57	Idler arm bracket, manual steering (shown)	8A-3351	11.95

### Ball Stud Seal



55-57	Seal, drag link to sector arm ball stud, with manual steering	B2A-3332-A	1.95
-------	---------------------------------------------------------------	------------	------



**Steering Gearbox Rebuild & Parts**

We can rebuild most gearboxes. Send us your complete rebuildable core & we will completely disassemble, clean, inspect & repair any problems. The usual turnaround time is 3 weeks from the date we receive your gearbox. Include your daytime phone number so that we can contact you if necessary. If for any reason, after disassembly & inspection, you decide not to proceed promptly with the rebuilding, only the return shipping costs will be charged.

55-57 Steering gearbox rebuild (estimate) . . .350445557 425.95

**Worm Gear Races**



55-57 Worm gear upper race . . . . . 8A-3553 21.95  
55-57 Worm gear lower race . . . . . B-3552 7.50

**Worm Roller Bearing (2 required)**



55-57 Steering gearbox worm roller bearing . . . . . 68-3571 6.95

**Sector Shaft Seals**



55-57 Except 3 tooth sector . . . . . 8A-3591-A 4.95  
56-57 With 3 tooth sector . . . . . 8M-3591 4.95

**Sector Shaft Bushings (2 required)**



55-56 With 2 tooth sector shaft . . . . . 68-3576 6.95  
56-57 With 3 tooth sector . . . . . B6A-3576-A 10.95

**Steering Shaft Seal**



55-57 Rubber . . . . . B5S-3738-A 3.95

**Gasket**



55-57 Steering gearbox gasket . . . . . AB-3581-A 1.95

**Plate & Tube**

55-57 Plate & tube, in gearbox housing . . . . . B5S-3597-A 10.95

**Housing Cap Gaskets & Set (as required)**



55-57 Housing cap gasket, .003" thick . . . . . B-3593-A 0.95  
55-57 Housing cap gasket, .010" thick . . . . . B-3593-C 0.95  
55-57 Set, 8 pieces, (4) .010" & (4) .003" . . . B-3593-AC 5.95 set

**Steering Sector Shaft Adjusting Screw**

55-57 1/2"- 20 x 1-13/32" . . . . . B7J-3577-A 6.95

**Steering Column to Dash Grommet**



55-57 Rubber . . . . . B5S-3512-A 7.95

**Steering Column Floor Seals**



55-57 Ford-O-Matic transmission (shown) . . B5S-3513-B 3.95  
55-57 Manual transmission . . . . . B5S-3513-A 3.95

**Steering Column Bracket Cover Insulators**



55-57 Black . . . . . B5S-3683-BLK 4.95  
55-57 White . . . . . B5S-3683-WHT 4.95

**Steering Wheels**



1956 Peacock . . . . . B6S-3600-PECO 315.95  
56-57 Unpainted . . . . . B6S-3600 315.95  
56-57 Black . . . . . B6S-3600-BLK 315.95  
1957 Red . . . . . B7S-3600-RED 315.95  
1957 White . . . . . B7S-3600-WHT 315.95  
1957 Blue . . . . . B7S-3600-BLU 315.95

We also carry parts for '56 & '57 horn rings. See page 66 for list.





## Power Cylinders & Parts

No more messing around with "iffy" original units. MAC's now has brand new, exactly as original power cylinders. Give us a call & we can send one your way right now!



55-56 Power cylinder, exactly like the original, includes bushings, washers & nuts . . . . . B5AZ-3A540-AN 269.95



1957 Power cylinder, exactly like the original, includes bushings, washers, spacer & nuts . . . . . B7AZ-3A540-AN 249.95

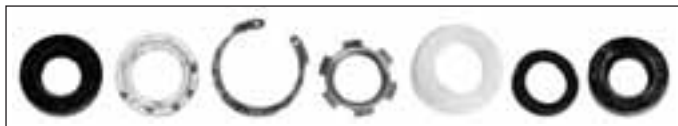

1957 Power cylinder seal kit . . . . . C1AZ-3A764-KT 14.95 kit



1957 Power cylinder rebuild kit, does not include accordion boot . . . C1AZ-3A540-KT 16.95 kit

### Power Cylinder Mounting Bushings



55-56 **NEW** Mounting kit, at the piston rod end, includes 2 rubber bushings & 1 nut. . . . . B3AZ-3C590-KT 9.95 kit



1957 **NEW** Mounting kit, at the piston rod end, includes 2 rubber bushings, 2 nuts & 1 sleeve . . . . . B7AZ-3C590-KT 14.95 kit



55-57 **NEW** Bushings, at the inner end, includes 2 specially tapered bushings that fit in the eye of the cylinder. . . . . B3AZ-3C589-A 3.95 pair

## Power Steering Pumps & Parts

The two power steering pumps listed below are not sold with a core. We rebuild yours. Send in your tired power steering pump & we will rebuild it, making sure it works like new. Allow 3-4 weeks for rebuilding after we receive your rebuildable unit.

55-56 Power steering pump rebuild, see note above . . . . . B5SZ-3A691-A 179.95  
 1957 Power steering pump rebuild, see note above . . . . . B7SZ-3A691-A 179.95  
 55-57 Power steering pump gasket & seal kit . . . . . B5AZ-3B584-KT 19.95 kit  
 55-57 Power steering pump reservoir cap gasket. . . . . B4AZ-3A006-G 1.95



55-57 Power steering pump reservoir lid gasket . . . . . COAA-3A642-B 2.95  
 55-57 Power steering pump adjusting bracket, front . . . . . B5AZ-3A732-A 19.95  
 55-57 Power steering pump rotor shaft bearing . . . . . 8BA-10094 11.95

### Power Steering Pump Filter



55-57 Power steering pump filter, inside pump reservoir, 3" OD x 1" ID x 1-3/8" high . . . . . AE-33538-A 10.95

### Shaft Oil Seal

55-57 Shaft oil seal . . . . . B3AZ-3B592-A 6.95

### Pulley



55-57 Balanced, painted, with correct casting numbers . . . B5AZ-3A733-A 47.95

### Bracket

55-57 From pump to exhaust manifold, steel, black powder coated finish . . . . . B5S-3562 47.95

### Reservoir Parts



55-57 **NEW** Gasket, for cover . . . . . COAA-3A642-B 2.95  
 55-57 Filter holder, lower, 55-early 57 . . . . . B5AZ-3C677-A 14.95



1957 Filter holder, lower, late 57 . . . . . B7S-3C677-A 14.95  
 55-57 Grommet, used where bolt goes thru reservoir lid. . . . . B9A-6570-A 1.95

### Bolt

55-57 Bolt, short bolt used to attach cast bracket to water pump . . . 354126-S 14.95



**Power Steering Control Valve to Pump Return Line & Clamp**



- 55-57 Power steering return line (shown) . . . . . B5AZ-3A713-C 22.95
- 55-57 Clamp, original style with correct screw, used on reservoir end of hose . . . B5A-2344-A 1.95

**Power Steering Control Valve to Power Cylinder Lines**



- 55-56 Use with B5SZ-3A717-A, below . . . B5SZ-3A714-B 24.95



- 55-56 Use with B5SZ-3A714-B, above . . . B5SZ-3A717-A 24.95



- 1957 (2 required) . . . . . B7SZ-3A714-A 20.95

**Power Steering Pump to Control Valve Pressure Lines**



- 55-57 With female fitting . . . . . B5SZ-3A719-A 41.95



- 1957 With male fitting. . . . . B7SZ-3A719-A 34.95

**Power Steering Control Valves & Parts**

*The two steering control valves listed below are not sold with a core. We rebuild yours. Allow 3 to 4 weeks for rebuilding after we receive your rebuildable unit.*

- 55-56 Power steering control valve rebuild . . . . . B5AZ-3A730-A 296.95
- 1957 Power steering control valve rebuild . . . . . B7AZ-3A730-A 296.95



- 55-56 Sleeve . . . . . B5AZ-3A754-A 25.95
- 1957 Sleeve (shown) . . . . . COAA-3A754-A 17.95
- 55-57 End cap for control valve, cast aluminum. . . . . B5S-3C705 15.95
- 55-56 Control valve ball stud shield . . . . . B5S-3A728-A 4.95
- 1957 Control valve ball stud shield . . . . . B7S-3A728-A 4.95

**Power Steering Hose Kits**

*Replace those leaky, dirty, discolored hoses with our new pressure, return & valve to cylinder lines. Get all the hoses you need & save money!*



- 55-56 With female fitting on the pressure line, includes:
  - B5AZ-3A713-C,
  - B5SZ-3A714-B,
  - B5SZ-3A717-A &
  - B5SZ-3A719-A . . . . . B5S-3A719-FKT 107.95 kit



- 1957 With female fitting on the pressure line, includes:
  - B5AZ-3A713-C,
  - (2) B7SZ-3A714-A &
  - B5SZ-3A719-A . . . . . B7S-3A719-FKT 100.95 kit

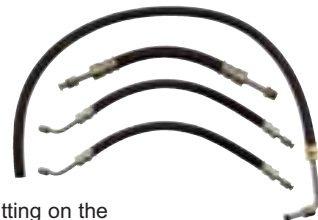



- 1957 With male fitting on the pressure line, includes:
  - B5AZ-3A713-C,
  - (2) B7SZ-3A714-A &
  - B7SZ-3A719-A . . . . . B7S-3A719-MKT 94.95 kit

**Power Steering Hose Insulator, Brackets & Arms**

- 55-57 Insulator for power steering hoses, rubber . . . . . B3AZ-3A609-A 8.95
- 55-57  U-shaped bracket & arm set. . . . . B5SZ-3A610-ST 21.95 set
- 55-57 Bracket, U-shaped, hose insulator listed above fits into this . . . . . B3AZ-3A610-A 15.95
- 55-57 Arm, bracket listed above bolts to this & this arm is bolted to the frame. . . . . B5SZ-3A611-A 15.95

**Alignment Shims**



- 55-57  1/16" thick . . . . . B5A-3054-A 1.95
- 55-57  1/8" thick, package of 10 . . . B-5000-SHK 5.75
- 55-57  Same as above, sold each . . . B-5000-SH 0.60



## Control Arm Bumpers



- 55-57 Upper control arm bumper, right or left (2 required) . . . . . B4AZ-3020-A 8.95
- 55-57 Lower control arm bumper, right . . . . . B5A-3019-A 8.95
- 55-57 Lower control arm bumper, left . . . . . B5A-3020-A 8.95

## Control Arm Bushings



- 55-57 Upper control arm front bushing, right or left (2 required) . . . . . LA-3068-A 6.95
- 55-57 Upper control arm rear bushing, right or left (2 required) . . . . . B4A-3087-B 6.95
- 55-57 Lower control arm bushing, front or rear, right or left (4 required) . . . . . COAA-3069-A 7.95

## Control Arm Shaft & Bushing Kits & Parts



- 55-57 Upper control arm shaft & bushing kit, includes shaft & 2 bushings, right or left, 1 kit does 1 arm (2 kits required) . . . . . B4A-3047-KT 44.95 kit
- 55-57 Upper control arm washer, outer, special cupped design (4 required) . . . . . B4A-3091-A 1.95
- 55-57 Upper control arm washer, inner, special cupped design (2 required) . . . . . B4A-3090-A 1.95



- 55-57 Lower control arm shaft & bushing kit, includes 2 shafts, 2 bolts, 2 sleeves, 2 bushings, 2 large washers & 2 lock washers, right or left, 1 kit does 1 arm (2 kits required) . . . . . B6A-3048-KT 99.95 kit
- 55-57 Lower control arm shaft, as original with extended shoulder & threaded end, includes lock washer & nut (4 required) . . . . . AD-3057 28.95
- 55-57 Lower control arm washer, special cupped design (6 required) . B4A-3091-A 1.95

## Ball Joints (2 required)

Unless your Bird has been up on blocks for the past 40 years, chances are that you need new ball joints. Made in the original style, our ball joints will help to restore that new car feel to your classic.



- 55-57 Upper ball joint, right or left . . . . . B5A-3049-A 74.95



- 55-57 Lower ball joint, right or left . . . . . B5A-3050-A 74.95

## Ball Joint Seal Set

Sometimes the ball joints are fine, but the rubber seals (or cups) are ripped, dry-rotted or altogether missing. MAC's is here to help you-we now sell these seals as a separate item!

- 55-57 4-piece set, rubber cups for the top of the ball joints . . . . . B4A-3332-ST 4.95 set



- 55-57 Original type (4 required) . . . . . B4A-3332-A 2.95

## Stabilizer Bar End Repair Kit



- 55-57 1 kit does both ends . . . . . B4AZ-5A486-KT 15.95 kit

## Stabilizer Bar Bushings & Bracket

- 55-57 Stabilizer bar bushings, 1 pair does both sides . . . . . B5S-5493-PR 10.95 pair
- 55-57 Stabilizer bar bracket (2 required) . . . . . 8M-5486 8.95

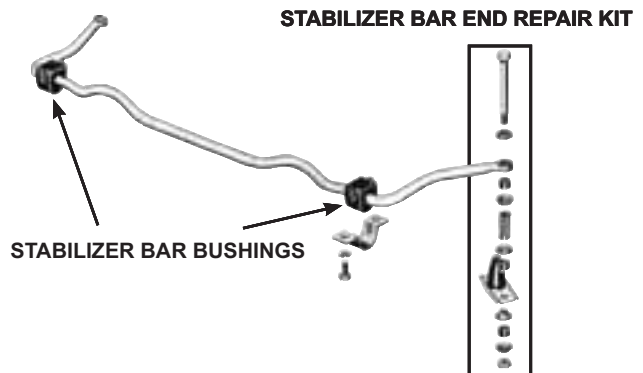



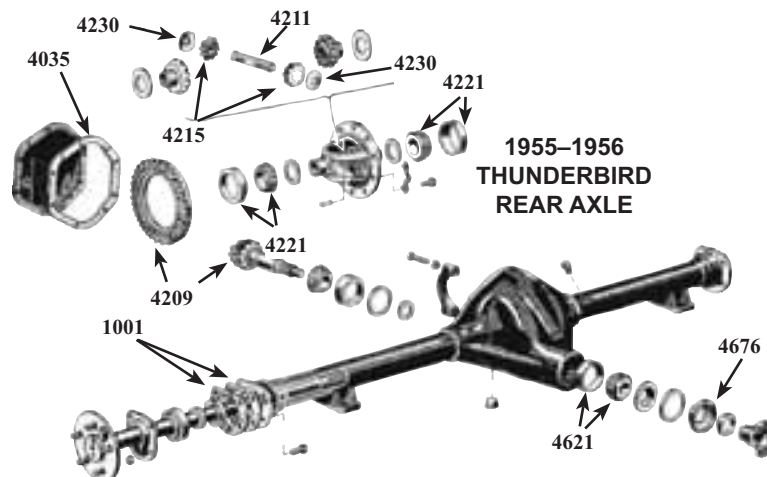

**1955-1956 THUNDERBIRD REAR AXLE**

**Rear Axle Grease Seal (2 required)**  
55-57 1-1/2" ID x 2-1/2" OD ..... B7A-1177-A 4.95

**Rear Wheel Bearing (2 required)**



55-57 Stamped 88128, 1-17/32" ID x 3-5/32" OD ..... C1SZ-1225-B 29.95

**Rear Axle Flange Gasket (4 required)**

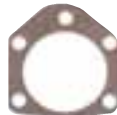

55-57 2 per side ..... A8AZ-1001-B 1.95

**Rear Axle Cover Gaskets**



55-56 ..... 1M-4035 4.95  
1957 ..... B7A-4035-A 3.95

**Differential Ring, Pinion & Pinion Shaft**

1957 9" ring gear, 3.25 ratio, *limited availability* ..... B8AZ-4209-C 362.95

**Differential Spider Gear & Thrust Washer (2 required)**



55-56 Differential spider gear (shown) ..... 8M-4215 37.95  
1955 Differential spider gear thrust washer, *Genuine Ford* ..... 8M-4230 2.95

**Differential Bearings & Races (2 required)**



55-56 Differential bearing & race ..... 8M-4221 36.95 set  
1957 Differential bearing & race ..... B7A-4221-B 19.95 set

**Rear Axle Pinion Bearings**

55-56 Front bearing & cup matched set ..... 8M-4621-ST 26.95 set  
55-56 Rear bearing cup ..... 8A-4628 12.95  
55-56 Rear bearing ..... 8M-4630 23.95



1957 Front bearing & cup matched set ..... B7A-4616-ST 20.95 set

**Rear Axle Pinion Pilot Bearing Retainer**

1957 *Genuine Ford* ..... B7AZ-4627-A 3.95

**Pinion Bearing Spacer**



1957 *Genuine Ford* ..... B7A-4662-A 7.95

**Rear Axle Pinion Bearing Retainer "O" Ring**

1957 4-3/4" inner diameter, *Genuine Ford* ..... B7A-4669-B 3.95

**Rear Axle Pinion Oil Seals & Gasket**

55-56 Rear axle pinion oil seal ..... 8M-4676 10.95  
55-56 Rear axle pinion oil seal gasket ..... 8M-4671 1.95  
1957 Rear axle pinion oil seal ..... B7A-4676-A 37.95

**Rear Axle Bumpers (2 required)**



1955 Includes plate (shown) ..... B6A-5783-A 11.95  
56-57 Plate, for rear axle bumper B7S-5783-A, listed below ..... B7S-5783-P 6.95  
56-57 ..... B7S-5783-A 7.95  
1957 Differential ..... B6A-5783-B 7.95

**Universal Joints**



1955 Front (not shown) ..... 4635-UJ556 17.95  
1955 Rear ..... 4635-UJ829 38.95  
56-57 Front or rear (2 required) ..... 4635-UJ680 16.95



## Shock Absorbers

MAC's Antique Auto Parts offers 3 types of shock absorbers for Little Birds:

**CURE-RIDE:** Specialty shock absorber manufacturer since 1937. These American-made gas shock absorbers are factory warranted for one year from the date of purchase.

**MOTORCRAFT:** Ford service replacement shock absorbers. These gas charged shock absorbers are factory warranted by the manufacturer for one year from the date of purchase.

**MONRO-MATIC PLUS:** Made in America by Monroe, these gas charged heavy duty shock absorbers are warranted by the manufacturer for one year from the date of purchase.

### Front Shock Absorber

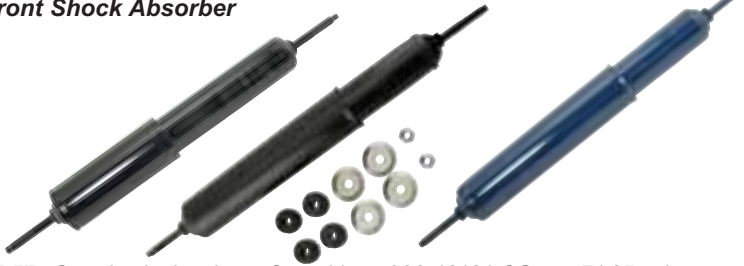

55-57 Gas shock absorbers, Cure-ride . . . A9A-18124-CG 74.95 pair

### Rear Shock Absorbers (2 required)

55-57 Rear shock absorber, gas-charged, **Motorcraft** . . . . . B2A-18125-F 35.95

55-57 Rear shock absorber, gas-charged, heavy-duty, Monro-Matic Plus . . . B2A-18125-M 27.95

## Front Coil Spring & Parts



55-57 Front coil spring (2 required) . . . . . B7S-5310-A 49.95

55-57 Front coil spring spacer, left side only . . . . . C1SS-5355-A 9.95

55-57 Front coil spring upper insulator (2 required) . . . . . B8A-5415-A 4.95

### Front Shock Absorber Bracket (2 required)



55-57 Front shock absorber lower bracket . . . AD-18072-A 14.95

## 55-57 Rear Suspension

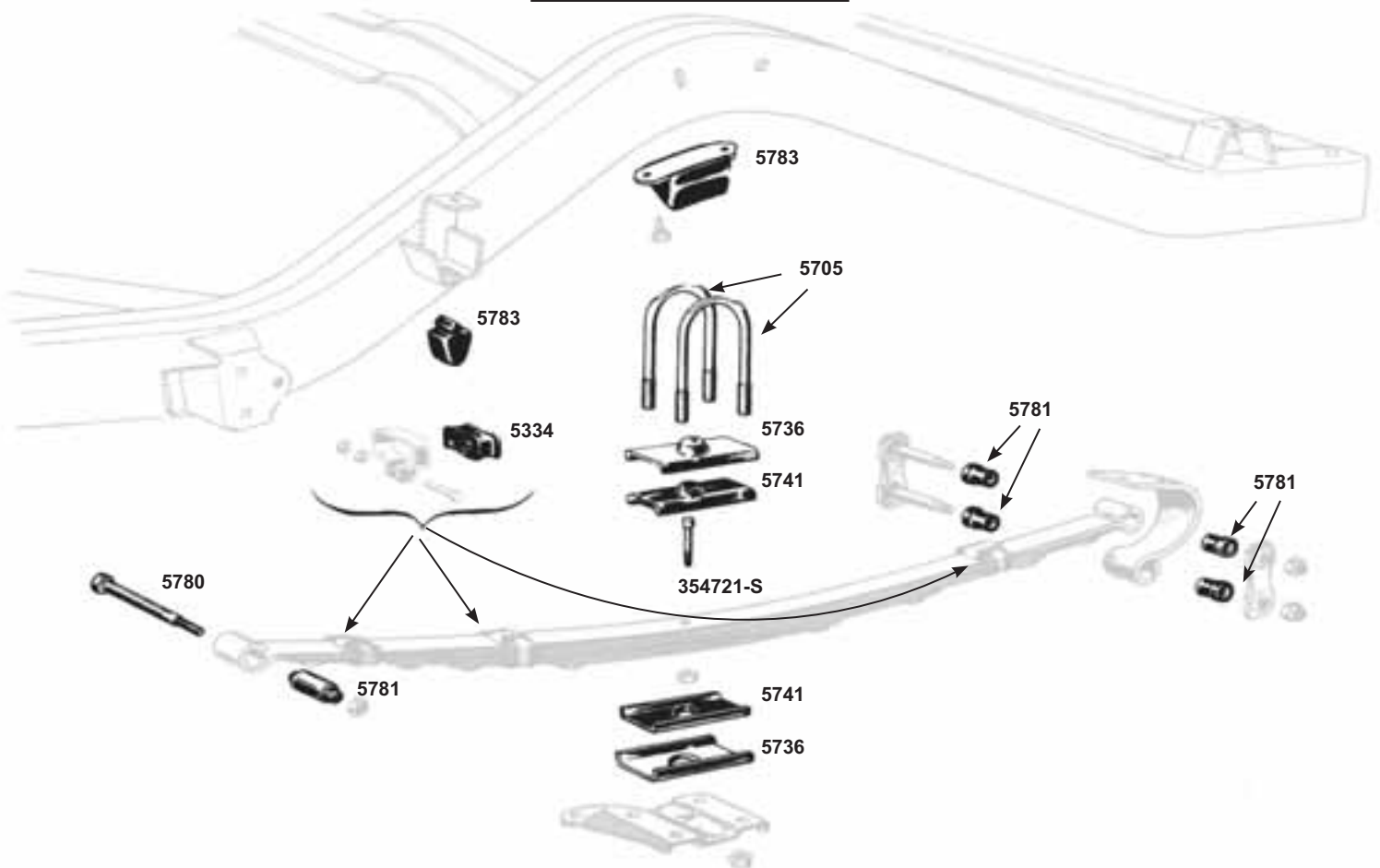



## Rear Leaf Springs (2 required)

- 1955 With cupped ends like original . . . . . B5S-5560-D 204.95
- 56-57 With cupped ends like original . . . . . B7S-5560-A 187.95

## Rear Shock Absorbers (2 required)

See images & information on page 34

- 55-57 Rear shock absorber, gas-charged, **Motorcraft** . . . . . B2A-18125-F 35.95
- 55-57 Rear shock absorber, gas-charged, heavy-duty, Monro-Matic Plus . . . B2A-18125-M 27.95

## Rear Shock Absorber Spring (2 required)



- 55-57 Rear shock absorber spring, fits over shocks to provide original look . . . B5S-18125-A 4.95

## Rear Leaf Spring Liners & Clamp

- 55-56 Liner, rubber (6 required) . . . . . B5S-5334 1.95



- 55-57 Liner set, rubber, 6 pieces, economy replacement style . . . . . 8A-5334-ST 7.95 set
- 1957 Liner, rubber (6 required) . . . . . B7S-5334 2.95
- 1957 Liner set, rubber (2 required) . . . . . B7S-5334-ST 9.95 set
- 1957 Clamp & liner set, 12 pieces, includes 6 liners, 6 clamps & instructions, exactly like original. . . . . B7S-5724-ST 20.95 set

## Rear Leaf Spring Front Hanger Bolt (2 required)

Note: This is the 56-57 style 7/16" size. It can be substituted for the 1955 3/8" bolt.

- 55-57 Bolt, for rear leaf spring front hanger, 7/16" x 20, this goes thru the front spring eye . . . . . B6SZ-5780-A 10.95

## Rear Leaf Spring "U" Bolt & Nut



- 55-57 Rear leaf spring "U" bolt (4 required) . B7A-5705-A 6.95
- 55-57 Special "tall" nut (8 required) . . . . . B7A-5705-NUT 1.95

## Rear Leaf Spring Center Pad, Retainer & Bolt



- 55-57 Rear leaf spring center pad (4 required) . . . . . B9SZ-5741-A 5.95
- 55-57 Rear leaf spring center pad retainer, 2-5/16" wide (4 required) . . . . . B2AZ-5736-A 7.95
- 55-57 Bolt, goes thru center pads & retainers & leaf spring (2 required) . . . . . 354721-S 4.95

## Rear Shackle Kit & Bushings



- 55-57 Rear shackle kit for rear of leaf spring, 1 kit does 1 spring, bushings are also available separately, see COAB-5781-A below . . . . . COAZ-5630-B 12.95 kit
- 55-57 Shackle bushing, rear of rear spring, included in COAZ-5630-B shackle kit (8 required) . . . . . COAB-5781-A 1.95
- 1955 Rear leaf spring bushing, front of spring (2 required) (not shown) . . . B5A-5781-C 14.95
- 56-57 Rear leaf spring bushing, front of spring (2 required) (not shown) . . . C1TT-5348-B 6.95

## Poly Slide Leaf Spring Liners

With all the time & effort you put into restoring your car, don't let something little like a squeak ruin your finished product! Use our Poly Slide Leaf Spring Liners to help fix that problem. A classic car is a beautiful thing, so get rid of that squeak in your spring! Call MAC's & order yours today! You cannot use original spring clips when installing because of the thickness added in each layer.



Designed to fit between spring leaves, they control friction & lessen squeaks. Molded in black with a "lip" to reduce movement & sold in convenient 20' rolls, choose your size & make that call to order yours today!

- 55-57 1-3/4" wide x 20' long . . . . . A5310PS1 9.95 roll
- 55-57 2" wide x 20' long . . . . . A5310PS2 10.95 roll
- 55-57 2-1/4" wide x 20' long . . . . . A5310PS3 11.95 roll

## Rear Leaf Spring Bumper (2 required)

- 55-56 Rubber, push-in type . . . . . B6A-5783-B 7.95

## Rear Leaf Spring Anti-Squeak



- 1955 Anti-squeak pad (16 required) . . . . . B8A-5586-A 1.95
- 56-57 Anti-squeak pad (12 required) . . . . . B8A-5586-A 1.95



- ALL Teflon tape, fits between the leaves, 3/4" wide x 520' long . . . . . TAPE 1.95





**How many do I need to order? All engine components listed are sold "each" except:**



**SET** = 1 set does one engine (piston rings, camshaft bearings & main bearings).  
**PAIR** = 1 pair makes one unit (split items, such as connecting rod bearings = order one pair for each connecting rod & valve keepers = order on pair for each valve stem).  
 All other items are sold EACH = count how many your car uses now (pistons, camshafts, cylinder sleeves, etc.).

## Cylinder Head Dowel Set



### 292 & 312 V-8

55-57 ..... C2OZ-6A008-A 4.95 set

## Cylinder Sleeves (8 required)

### 292 V-8

55-57 3/32" wall, nominal bore 3.750" x length 6.062" ..... B5AZ-6055-A 20.95

### 312 V-8

56-57 3/32" wall, nominal bore 3.800" x length 6.000" ..... C2DZ-6055-A 23.95

56-57 1/8" wall, nominal bore 3.800" x length 6.000" ..... C2DZ-6055-B 23.95

## Exhaust Valve Seat (8 required)

### 292 & 312 V-8

55-57 High-chrome steel, heavy-duty. .... B5AZ-6057-F 4.95

## Pistons, With Pins, Aluminum (8 required)



### 292 V-8

55-57 Standard size ..... B6A-6108-A 32.95  
 55-57 0.020" oversize ..... B6A-6108-C 32.95  
 55-57 0.030" oversize ..... B6A-6108-D 32.95  
 55-57 0.040" oversize ..... B6A-6108-E 32.95  
 55-57 0.060" oversize ..... B6A-6108-G 32.95

### 312 V-8

56-57 Standard size ..... ECZ-6108-A 41.95  
 56-57 0.020" oversize ..... ECZ-6108-C 41.95  
 56-57 0.030" oversize ..... ECZ-6108-D 41.95  
 56-57 0.040" oversize ..... ECZ-6108-E 41.95  
 56-57 0.060" oversize ..... ECZ-6108-G 41.95

## Main Bearing Sets (8 required)

### 292 V-8

55-57 Standard size ..... EBV-6333-A 74.95 set  
 55-57 0.020" undersize ..... EBV-6333-C 74.95 set  
 55-57 0.030" undersize ..... EBV-6333-D 74.95 set  
 55-57 0.040" undersize ..... EBV-6333-E 74.95 set

## Connecting Rod Bearings (8 required)

### 292 & 312 V-8

55-57 Standard size ..... B5T-6211-A 11.95 pair  
 55-57 0.010" oversize ..... B5T-6211-B 11.95 pair  
 55-57 0.020" oversize ..... B5T-6211-C 11.95 pair

## Connecting Rod Bushing (8 required)



### 292 & 312 V-8

55-57 Connecting rod wrist pin bushing ..... EAA-6207-A 1.95

## Piston Rings

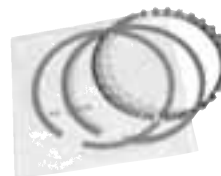

### 292 V-8

55-57 Standard size, cast iron ..... B5AZ-6149-A 39.95 set  
 55-57 0.020" oversize, cast iron ..... B5AZ-6149-C 39.95 set  
 55-57 0.030" oversize, cast iron ..... B5AZ-6149-D 39.95 set  
 55-57 0.040" oversize, cast iron ..... B5AZ-6149-E 39.95 set  
 55-57 0.060" oversize, cast iron ..... B5AZ-6149-G 39.95 set

### 55-57

55-57 Standard size, moly. .... B5AZ-6149-MA 51.95 set  
 55-57 0.020" oversize, moly ..... B5AZ-6149-MC 51.95 set  
 55-57 0.030" oversize, moly ..... B5AZ-6149-MD 51.95 set  
 55-57 0.040" oversize, moly ..... B5AZ-6149-ME 51.95 set  
 55-57 0.060" oversize, moly ..... B5AZ-6149-MG 51.95 set

### 312 V-8

56-57 Standard size, cast iron ..... B6AZ-6149-A 42.95 set  
 56-57 0.020" oversize, cast iron ..... B6AZ-6149-C 42.95 set  
 56-57 0.030" oversize, cast iron ..... B6AZ-6149-D 42.95 set  
 56-57 0.040" oversize, cast iron ..... B6AZ-6149-E 42.95 set  
 56-57 0.060" oversize, cast iron ..... B6AZ-6149-G 42.95 set

### 56-57

56-57 Standard size, moly. .... B6AZ-6149-MA 62.95 set  
 56-57 0.020" oversize, moly ..... B6AZ-6149-MC 62.95 set  
 56-57 0.030" oversize, moly ..... B6AZ-6149-MD 62.95 set  
 56-57 0.060" oversize, moly ..... B6AZ-6149-MG 62.95 set

## Camshaft

### 292 & 312 V-8



55-57 Mechanical ..... B5A-6250-C 81.95

## Camshaft Thrust Plate

### 292 & 312 V-8

55-57 ..... EAA-6269-A 9.95

## Cam Bearing Set

### 292 & 312 V-8

55-57 Standard size ..... C2AZ-6A251-A 45.95 set

## Valve Lifter (16 required)

### 292 & 312 V-8



55-57 Mechanical ..... B8C-6500-A 11.95

## Exhaust Valves (8 required)

### 292 & 312 V-8

55-57 Standard size ..... C3AZ-6505-A 9.95  
 55-57 0.015" oversize ..... C3AZ-6505-C 9.95

## Intake Valves (8 required)

### 292 & 312 V-8



55-56 Standard size ..... B4AZ-6507-A 7.95  
 1957 Standard size ..... B7A-6507-A 9.95



**Valve Guides** (8 required for each intake & exhaust)

- 292 V-8**
- 55-56 Standard size, plain, 0.344" ID, intake or exhaust. . . . . B4AZ-6510-A 1.95
  - 55-56 Standard size, plain, 0.343" ID, intake only. . . . . B4AZ-6510-C 1.95
  - 55-56 Standard size, spiral groove, 0.343" ID, intake only. . . . . B4AZ-6510-D 3.95
  - 1957 Standard size, plain, 0.344" ID, intake or exhaust. . . . . B5AZ-6510-A 1.95
  - 1957 Standard size, spiral groove, 0.344" ID, intake or exhaust. . . . . B5AZ-6510-B 1.95

- 312 V-8**
- 56-57 Standard size, plain, 0.344" ID, intake only. . . . . B4AZ-6510-A 1.95
  - 56-57 Standard size, plain, 0.343" ID, intake only. . . . . B4AZ-6510-C 1.95
  - 56-57 Standard size, spiral groove, 0.343" ID, intake only. . . . . B4AZ-6510-D 3.95
  - 56-57 Standard size, plain, 0.344" ID, exhaust only. . . . . B5AZ-6510-A 1.95
  - 56-57 Standard size, spiral groove, 0.344" ID, exhaust only. . . . . B5AZ-6510-B 1.95

**Valve Spring** (16 required)

- 292 & 312 V-8**
- 55-57 Intake or exhaust. . . . . B6A-6513-A 1.95

**Valve Spring Inserts (Shims)** (as required)

- 292 & 312 V-8**
- 55-57 0.030" thick, **limited availability** . . . B4AZ-6515-A 0.95
  - 55-57 0.060" thick, **limited availability** . . . B4AZ-6515-B 0.95

**Valve Keeper** (16 required)



- 292 & 312 V-8**
- 55-57 Chrome-moly steel, intake or exhaust. . . . . 7HA-6518 0.50 pair

**Rocker Arm Shaft** (2 required)



- 292 & 312 V-8**
- 55-57 Standard replacement. . . . . B4AZ-6563-A 22.95

**Rocker Arms & Parts** (16 required)



- 292 & 312 V-8**
- 55-57 . . . . . COAZ-6564-A 32.95
  - 55-57 Oil outlet tube, mounted on rocker arm shaft support (2 required) . . . B5A-6588-A 7.95
  - 55-57 Oil outlet tube bracket, mounted on rocker arm shaft support (2 required) . . . . . EBU-6575-A 3.95

**Pushrods** (16 required)

- 292 & 312 V-8**
- 1955 Standard size . . . . . EBU-6565-B 3.95
  - 56-57 Standard size . . . . . COAE-6565-D 3.95





**Valve Stem Seal** (16 required)



- 292 & 312 V-8**
- 55-57 Umbrella type, intake or exhaust . . . B4AZ-6571-A 1.95

**Engine Block Vent Cover & Bolt Set**



- 1957  On the left side of the engine block . . . . . B5S-6869-A 6.95
- 1957  Bolt & lock washer set for above vent cover (2 required). . . . . 4HK11A 1.95 set

**Timing Chains & Gears**

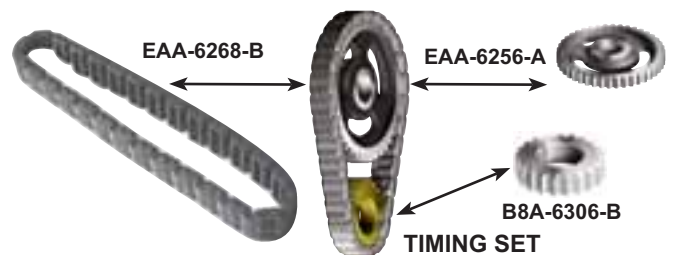

- 292 & 312 V-8**
- 55-57 Timing chain . . . . . EAA-6268-B 28.95
  - 55-57 Timing set, 3-piece set, includes camshaft & crankshaft gears & timing chain. . . EAA-6268-ST 57.95 set
  - 55-57 Camshaft gear, 42 teeth . . . . . EAA-6256-A 24.95
  - 55-57 Crankshaft gear, 21 teeth . . . . . B8A-6306-B 11.95

**Timing Pointer**

- 55-57 Timing pointer, 292 & 312, **except supercharged** . . . . . B5S-6023-B 14.95

**Crankshaft Parts**



- 55-57 Harmonic balancer repair sleeve, 292 & 312 . . . . . B5S-6312 15.95
- 55-57  Woodruff key, for crank gear, 292 & 312 . . . . . 74175-S 0.95

**Flywheel Parts**

**Flex Plate & Flywheel Ring Gear**



- 55-57 Flex plate with reinforcement rings, Ford-O-Matic transmission . . . . . B7A-6375-A 55.95
- 55-57 Flywheel ring gear, 146 teeth, manual & overdrive transmission . . . . . EAA-6384-A 20.95

**Starter to Flywheel Housing Seal**



- 55-57 Starter to flywheel housing seal, all V-8 . . . . . C2AZ-6436-A 10.95



## Oil Pressure Sending Unit



55-57 Sending unit . . . . . B6AZ-9278-B 7.95

## Oil Pump & Parts



55-56 Oil pump, gear type pump, new, not rebuilt . . . . . C1AE-6600-A 84.95



55-57 Oil pump screen . . . . . 41A-6623 22.95  
 55-57 Nut, pickup screen tube to oil pump . . . . . EAD-6673-A 15.95  
 55-57 Gasket . . . . . B6Q-6659-A 2.95



1957 Oil pump rebuild kit, rotor type . . . . . B7S-6600-8KT 29.95 kit  
 55-57 Oil pump driveshaft . . . . . C1AZ-6A618-A 7.95

## Oil Pan Drain Plugs



55-56 Oil pan drain plug, 7/8"-16 . . . . . 8HA-6730 7.95  
 1957 Oil pan drain plug, 1/2"-20 . . . . . C3AZ-6730-A 2.95  
 1957 Oil pan drain plug gasket, nylon, 1/2" ID . . . . . C2OZ-6734-A 2.95

## Oil Filter Conversion Kit



55-57 Oil filter conversion kit, converts from canister-type to our C1AZ-6731-M spin-on oil filter . . . . . B7A-6882-A 29.95

## Oil Dipstick & Dipstick Tube

55-57 Spring steel as original . . . . . B5S-6750-B 21.95  
 55-57 Dipstick tube, includes bracket . . . . . B5S-6754-B 23.95

## Draft Tube & Gasket

55-57 Draft tube or road tube . . . . . B7A-6758-B 47.95  
 55-57 Gasket, for draft tube . . . . . B4A-6872-A 0.95

## Oil Filler, Breather Caps



55-56 Gloss black, push-on type, exactly as original with raised center & "FRONT" in raised letters with arrow underneath (shown) . . . . . B5A-6766-A 23.95  
 55-56 Chrome, push on type, exactly as original with raised center & "FRONT" in raised letters with arrow underneath . . . . . B5S-6766-A 27.95  
 55-57 Replacement push-on type . . . . . EAD-6766-A 9.95



1957 Gloss black, with correct logo, for engines without dress-up kit . . . . . B6A-6766-A 23.95

## ZDDPlus Motor Oil Additive

*Major oil companies have been significantly reducing the level of ZDDP (zinc) in motor oil over the past few years. This vital anti-wear ingredient is necessary in all flat-tappet classic vehicle engines. By adding one bottle of ZDDPlus each time you change your oil, that protection will be maintained, no matter what brand or viscosity motor oil you've been using.*



ALL Oil additive, 4 oz. bottle . . . . . ZDDPLUS 9.95

**For  
Oil Filters  
& Parts  
See Page 40**





## GASKET SET CONTENTS:

**HEAD SET:** Contains all necessary gaskets & seals required to remove & replace the cylinder heads & to grind the valves. Does not contain carburetor, carburetor PCV adapter block or large tin "bathtub" intake manifold gaskets.

**VALVE COVER SET:** Contains valve cover gaskets & any necessary seals or grommets required for installation.

**TIMING COVER SET:** Contains all gaskets & all seals needed for removal & replacement of the timing cover. Will contain oil pan gasket replacement ends if the oil pan gasket must be replaced for a proper installation.

**REAR MAIN SEAL SET:** Contains rear main bearing seal & any attaching part gaskets or side seals.

**OIL PAN GASKET:** Contains oil pan gasket(s), oil drain plug gasket & oil pick-up tube gasket if required for removal & replacement of oil pan.



### 292 & 312 V-8

- 55-57 Engine overhaul set (shown) . . . . COAZ-6008-ST 139.95 set
- 55-57 Timing cover set . . . . . B4A-6020-ST 15.95 set
- 55-57 Valve cover gasket, for steel valve covers, does not include grommets (2 required) . . B4AZ-6A506-A 8.95
- 55-57 Valley pan gasket . . . . . COAE-6521-A 4.95



- 55-57 Hex nut set, 4 pieces, for stamped steel valve covers (shown) . . . . . 354526-ST 8.95 set
- 55-57 Acorn nut set, 4 pieces, chrome, for factory optional aluminum valve covers . . . . . 354526-CHST 9.95 set
- 55-57 Washer set, 4 pieces, chrome, for factory optional aluminum valve covers . . . . . 354054-ST 4.95 set
- 55-57 Rocker arm stud, longer for use with factory optional aluminum valve covers (4 required) . . . . . B5SZ-6A527 2.95

- 55-57 Aluminum valve cover installation kit, includes 4 chrome acorn nuts, 4 chrome washers, 4 longer rocker arm studs & a valve cover gasket . . . . . B5SZ-6582-KT 35.95 kit
- 55-57 Intake manifold gasket set . . . . . B7AZ-9433-A 9.95 set
- 55-57 Exhaust manifold gaskets . . . . . B4A-9448-A 12.95 pair



- 55-57 Rear main seal, neoprene, 312 V-8 only (shown) . . . . . B6A-6701 45.95
- 55-57 Head gasket (2 required) . . . . . B7AZ-6051-A 25.95
- 55-57 Head set . . . . . B7AZ-6079-ST 120.95 set
- 55-57 Valley pan gasket, rubber, includes grommets . . . . . COAE-6521-RST 8.95 set
- 55-57 Oil pan gasket, cork . . . . . COAZ-6710-C 14.95

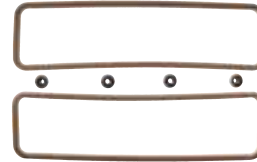

- 55-57 Valve cover set, cork, includes grommets, for steel valve covers (shown) . . . . . B4AZ-6A506-CST 15.95 set
- 55-57 Rear main seal set, neoprene, 2 pieces, 292 V-8 only . . . . . B5A-6701-ST 18.95 set
- 55-57 Valve cover gasket set, cork, includes grommets, for aluminum valve covers, 312 V-8 only . . . . . B4AZ-6A506-ALST 20.95 set
- 55-57 Rear main seal set, rope type . . . . B4MY-6701-ST 9.95 set

## Engine Hardware Kit

You carefully painted the engine block, the water pump, the valve covers & now you are going to bolt everything together with hardware that will start to rust almost immediately? All that hard work deserves a reward, so reward yourself with our Engine Hardware Kit. It has every nut, bolt & washer you'll ever need & every bit of it is crafted from rust free stainless steel for good looks today, tomorrow & well into the future.

Kit contains hardware for the oil pan, timing chain cover, water pump, thermostat housing, intake manifold & the valve covers.

- 55-57 292 & 312 . . . . . 6-0950 49.95

## Sealers

- ALL Head gasket sealant, fills in small scratches & imperfections, eliminates hot spots & prevents seizing of connections & fittings, resists heat up to 525°, use on exhaust manifolds, cylinder heat gaskets & carb base gaskets, 9 oz. spray can . . . . . RSP32 \* 8.15



- ALL Permatex "Form-a-Gasket," silicone, replaces almost any cut gasket, 3 oz. tube . . . . . RSP50 4.95

- ALL All-purpose gasket sealant, this is a general-purpose gasket maker & sealant. It works well with cork & paper gaskets, locking out fuel, anti-freeze & oil, 4 oz. can with brush in lid . . . . . RSP25 \* 5.45



- ALL Gasket sealer, used to replace cork, rubber, silicone, felt & other cut gaskets to form a leak-proof seal. Resists oil, grease, water, antifreeze mixture & transmission fluid. More flexible than conventional gaskets, it can be used on water pumps, exhaust manifolds, valve covers, timing gear covers, transmission pans, water neck outlets or any place a high-performance gasket is needed, 3 oz. tube . . . . . A5251SEAL 4.95



## Permatex Gasket Remover

Quickly removes all types of baked-on gaskets, adhesives & sealants.

- ALL 12 oz. spray can . . . . . RSP52 \* 5.95



\* **HAZARDOUS MATERIAL** can only be shipped by ground/ surface within the U.S. because of government regulations.

# EXHAUST



## Exhaust Heat Riser Valves & Spacer

55-57	Exhaust heat riser valve, with stainless rod & flapper . . . . .	B5S-9A427-SS	94.95
55-57	Exhaust heat riser valve, with stainless rod, without flapper . . . .	B5S-9A427-A	94.95
55-57	Exhaust heat riser spacer, cast, replaces heat riser valve . . . . .	B5S-9A427-SP	18.95

## Exhaust Manifolds

55-57	Right, 1957 style, replacement for 55 & 56 . . . . .	C2AZ-9430-A	250.95
55-57	Left, with "FoMoCo" logo . . . . .	B7S-9431-A	250.95

## Exhaust Deflectors

1956	Exhaust deflector, right . . . . .	B6S-5202-C	36.95
1956	Exhaust deflector, left . . . . .	B6S-5203-C	36.95
1957	Steel (2 required) . . . . .	B7S-5202-A	31.95
1957	Stainless steel (2 required) . . . . .	B7S-5202-SS	49.95

## Smithy's Mufflers

Now you too can have that nostalgic mellow tone that only a Smithy's muffler produces. With a beautiful hammer tone finish, 3-1/2" case diameter & a 2" inlet & outlet, not only do they look great, they are available in three lengths to fit virtually any car or truck in your stable.



**A GREAT AND POPULAR ITEM!**

ALL	22" case (as required) . . . . .	H3010	39.95
ALL	<b>Save</b> 22" case, sold as a pair . . . .	H3010PR	70.95 pair
ALL	26" case (as required) . . . . .	H3011	43.95
ALL	<b>Save</b> 26" case, sold as a pair . . . .	H3011PR	78.95 pair
ALL	30" case (as required) . . . . .	H3012	45.95
ALL	<b>Save</b> 30" case, sold as a pair . . . .	H3012PR	83.95 pair



ALL	<b>NEW</b> "Smithy's" muffler decal, show everyone why your classic car sounds so good! . . . . .	DZ309	4.95
-----	---------------------------------------------------------------------------------------------------	-------	------

# FILTERS

## Oil Filters & Parts

Everyone knows the importance of changing your oil regularly in your daily driver. It's important to do the same with your Thunderbird. Nothing benefits an engine more than fresh oil & a new filter free from dirt & sludge. So give us a call, whether you have a canister type or a spin-on style, we'll be happy to send you a premium quality filter right away!



55-56	Oil filter, for canister type, 4" ID x 4-3/4" long, rubber seal included, <b>Motorcraft</b> . . . . .	C1TZ-6731-M	7.95
55-57	Spring, for canister type oil filter . . . .	B2A-6889-A	5.95
55-57	Rubber seal, for canister . . . . .	EAA-6838-A	1.95



1957	Oil filter, spin-on, <b>Motorcraft</b> . . . . .	C1AZ-6731-M	7.95
1957	<b>NEW</b> Oil filter, spin-on, Hastings brand, with anti-drain back feature, oil light goes out immediately upon start up . . . . .	C1AZ-6731-H	8.95

## Fuel Filters

Dirt in your fuel lines is a problem, if that dirt gets to your carburetor, it's a major problem. Once dirt gets into your carb, you might have no other choice but to rebuild it & that takes time & can be costly. Save yourself the trouble & expense, install a new fuel filter today.



55-57	Fuel filter with glass bowl, in-line type, does not have domed top like original . . . . .	B7S-9155-A	20.95
-------	--------------------------------------------------------------------------------------------	------------	-------

Do you also want an in-line fuel filter for your car? Our in-line fuel filter fits every car. Just plumb it into your fuel line & protect your carb from dirt & other contaminants.

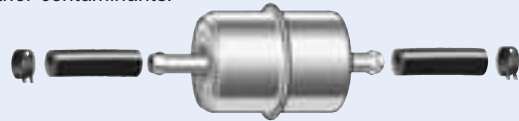

ALL	<b>NEW</b> In-line type, includes hoses & clamps . . . . .	C2RZ-9155-H	6.95
-----	------------------------------------------------------------	-------------	------

## Air Filter



1957	Air filter, V-8 292 & 312, single 4 bbl carburetor only, 13-1/4" OD x 11-5/16" ID, please verify size, <b>Motorcraft</b> . . . . .	B7SZ-9601-M	13.95
------	------------------------------------------------------------------------------------------------------------------------------------	-------------	-------



### Front Motor Mounts & Rear Transmission Mounts

Can there be a more overworked or more under appreciated part of your T-Bird than the lowly motor or transmission mount? Every time we rev our high-powered Thunderbird engines, the poor mounts are stretched almost to the point of tearing apart. Every little oil leak seems to find its way to the sensitive rubber part of every mount, while exhaust & engine heat combine to cook mounts into an early grave. Yet, these motor & transmission mounts have the vital tasks of keeping our drive trains properly centered & safely anchored under every condition, while also isolating engine vibrations from the chassis & passenger compartment. Have a heart & replace those worn & weakened motor & transmission mounts today!

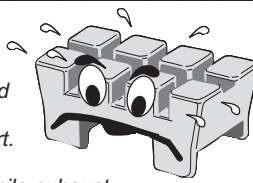

These motor mounts are the rubber-coated metal parts only. They do not include any mounting hardware.



55-57 Front upper motor mount insulator, V-8 292 & 312 . . . . . B5S-6038-A 19.95



55-57 Front lower motor mount insulator, V-8 292 & 312 . . . . . TAAA-6039-AR 5.95



55-56 Transmission mount, V-8 292 & 312 . . .AD-6068-D 15.95  
1957 Transmission mount, V-8 292 & 312 . . B7A-6068-A 12.95



55-57 Special nut, for front upper & lower insulator stud, 9/16"-18 special round. B3T-6041-A 7.95  
55-57 Retainer, transmission mount . . . . . B7A-6054-A 27.95  
55-57 Front upper support spacer, V-8 292 (as required) . . . . . B5S-6A027-A 3.95

### Engine Steady Rest Kits & Parts

55-57 Engine steady rest bracket, right . . . . B5S-6954-R 15.95  
55-57 Engine steady rest bracket, left. . . . . B5S-6954-L 15.95  
55-57 Engine steady rest grommet kit, 8 pieces, 1 kit does both sides . . . . . B5S-6966-KT 11.95 kit  
55-57 Engine steady rest washer kit, 5 pieces, 1 kit does 1 side (2 kits required) . . B5S-6953-KT 6.95 kit  
55-57 Engine steady rest rod (2 required) . . B5S-6968-A 6.95



55-57 Engine steady rest hardware kit, 1 kit does 1 side, includes 1 rod (6968), 5 washers (6953), 4 grommets (6953) & 3 nuts (34370SB nuts not available separately), brackets not included, but are listed above (2 kits required) . . B5S-6960-KT 18.95 kit

### Body to Frame Mounting Parts

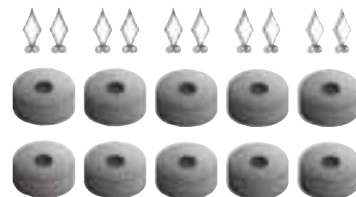

55-57 Insulator kit, includes (10) B5S-5006-A & (10) B5S-5007-A . . . . . B5S-5008-KT 29.95 kit  
55-57 Clip (10 required) . . . . . B5S-5006-A 0.95  
55-57 Rubber bumper (10 required) . . . . . B5S-5007-A 2.95  
55-57 Body to frame welt, 1/8" x 2" x 20" . . . . . B5000 21.95 roll



55-57 1/16" thick . . . . . B5A-3054-A 1.95  
55-57 1/8" thick, package of 10 . . . B-5000-SHK 5.75  
55-57 Same as above, **except** each . . . B-5000-SH 0.60

### Insulation & Sound Deadener (as required)

#### Firewall Insulation

If you are replacing your carpet, now is the best time to install superior firewall insulation. We carry everything you'll need. Our big 48" x 72" sheet is a full 5/16" thick & is rated to R18 (meaning it resists heat up to 700°). It's constructed of jute fiber with a space age reflective foil bonded to both sides. You can put it on the firewall, behind the kick panels or even on the trunk divider. It does the job of blocking intrusive road noise & keeping engine heat in the engine compartment where it belongs.



ALL Firewall insulation, 48" x 72" x 5/16", cut to fit desired area . . . . . V700770X 32.00

#### Sound Deadener by Dynamat®

For years, we have been selling the original Dynamat & can boast hundreds of satisfied customers. We are now proud to offer the next generation of Dynamat sound deadeners: Xtreme. Xtreme is a step up from the original formula & is Dynamat's best product at controlling vibration. It damps 4 times as much as the original Dynamat &, as an added bonus, it weighs 50% less. It is available in conveniently sized 18" x 32" sheets & with peel & stick application; it goes on quickly & easily. Do yourself a favor & order some today!



ALL Dynamat® Xtreme, each piece is 18" x 32" (as required) . . . . . DYNAMAT-0433 29.95

#### Jute Backing

Ever wonder what that stuff is on the back of your carpet? It's called jute fiber & it provides a cushion underneath your carpet as well as sound insulation. We have it available in 36" x 72" sheets that are 5/16" thick. You cut the size you need for the area you want to put it in.



ALL Synthetic jute fiber, 36" x 72" x 5/16", cut to fit . . . . . B13000 15.95

#### General Trim Adhesive

MAC's recommends the following adhesive for attaching jute padding to metal or plastic.



ALL Adhesive, 18.1 oz. spray . . . . . RSP29 \* 14.75

\* **HAZARDOUS MATERIAL** can only be shipped by ground/ surface within the U.S. because of government regulations.





## Shift Knob

55-57 Shift knob, manual & overdrive transmission . . . . . BB-7213-AR 5.95

## Extension Housing Bushing & Seals

55-57 Extension housing bushing, V-8 292 . . . . . B3TZ-7A034-A 5.95  
 55-57 Extension housing seal, V-8 292 . . . . . 21C-7052 5.00  
 1957 Extension housing seal, V-8 312 . . . . . C3AZ-7052-A 9.95

## Overdrive Housing Bushing & Seals



1955 Overdrive housing bushing, V-8 292 . . . . . B3TZ-7A034-A 5.95  
 1955 Overdrive housing seal, V-8 292 . . . . . 21C-7052 5.00  
 56-57 Overdrive housing seal, V-8 312 . . . . . C3AZ-7052-A 9.95

## Manual Transmission Gasket Sets



1955 V-8 292 with overdrive . . . . . B8AZ-7153-A 14.95 set  
 55-56 V-8 292 & 312 without overdrive . . . . . B8AZ-7153-A 14.95 set  
 56-57 V-8 312 with overdrive . . . . . B6A-7153-D 16.95 set  
 1957 V-8 292 without overdrive . . . . . B8AZ-7153-A 14.95 set  
 1957 V-8 312 without overdrive . . . . . B6A-7153-D 16.95 set

## Clutch Fork Boot



55-57 Leather . . . . . AB-7513-B 30.95

## Clutch Arm Return Spring



55-57 Clutch arm return spring . . . . . MB-7523-A 3.95

## Clutch Release Equalizer Shaft Parts



56-57 Clutch release equalizer shaft bushing . . 01A-7517 4.25 pair  
 55-57 Clutch release equalizer shaft washer . . . . . 01A-7539-A 0.95  
 55-57 Clutch release equalizer shaft spring, for clutch equalizer shaft, original Ford part number AB-7545-A (not shown) . . . . . B2A-6889-A 5.95

## Clutch Retracting Spring Bracket

55-57 Clutch retracting spring bracket . . . . . B5S-7542-A 9.95

## Manual Transmission Shift Lever Boot



55-57 Gearshift lever boot, manual transmission only . . . . . B6S-7277-A 17.95

## Clutch Rod Firewall Seal



55-57 Rubber boot type, for clutch rod . . BA-7527 14.95

## Clutch Rod Bolt & Washer

55-57 Bolt, with special shoulder, for clutch rod (2 required) . . . . . 355702-S 3.95  
 55-57 Washer, for special shoulder bolt listed above (4 required) . . . . . 356383-S 1.95

## Clutch Disc & Pressure Plate



55-57 Clutch disc, 11" diameter . . . . . B6A-7550-D 39.95  
 55-57 Clutch pressure plate, 11" diameter . . . . . 51-7563 105.00  
 55-57 Alignment tool, 10 spline . . . . . F7550A 7.95

## Throwout Bearing & Hub Sets



55-57 Throwout bearing . . . . . 8A-7580-A 19.95  
 55-56 Throwout bearing & hub set . . . . . AB-7561-ST 29.95 set  
 1957 Throwout bearing & hub set . . . . . B7A-7561-ST 36.95 set

## Clutch Pilot Bearing



55-57 Bronze "Oillite" style . . . . . 70-7600 4.15

## Back-up Light Switch & Actuator



55-57 Switch, with manual or overdrive transmission (shown) . . . . . 51A-15520-A 8.95  
 55-57 Switch actuator . . . . . B5S-15540-A 18.95

## Overdrive Cable & Handle



55-57 Includes 80" of cable & a chrome handle (cut to fit) . . . . . A9AZ-7A650-A 49.95

## Overdrive Kickdown Switch



55-57 Overdrive kickdown switch . . . . . A9AZ-7A652-A 35.95

## Overdrive Governor Cover

55-57 Rubber . . . . . 8M-6941 5.95

## Overdrive Solenoid Seal

55-57 Overdrive solenoid seal, at adapter . . . . . 26H-7693 9.95

## Neutral Safety Switch

55-57 With Ford-O-Matic 3 speed automatic . . . . . B6SZ-7A247-A 82.95



## Which Transmission Do I Have?



Instead of coming up with two separate transmission names, Ford Motor Company decided to call the two different versions of the Ford-O-Matic the "small case" & the "medium case." If you are lucky enough to still have the tag on your tranny it's simple to figure out which one you have:

The prefix of the engineering number for the small case in 1955 is either PAG or PAK & in 1956 it would be PAP or PAR. The prefix for the medium case in 1955 was PMB, in '56 it was PAW & in '57 it was PBA.

For many of you that tag will be long gone, so let's go to plan "B," actually, plan "B" & plan "C," just to be sure. The "small case" tranny was only used in Ford cars. The "medium case" tranny was able to handle more power & torque & therefore was used in Thunderbirds, Mercurys, police cars & the 1956 Ford station wagon with the 312 engine.

Problem solved ... except that your car is 50 + years old & it might not have the original transmission anymore. On to plan "C": the case was shorter in the "small case" transmission, hence its name. It's 9-7/8" long & in the "medium case" transmission, it's 10-7/32" long. That's great, except you say you're not exactly sure what part of the transmission the case actually is so the length doesn't really help that much. Please refer to our illustration above.

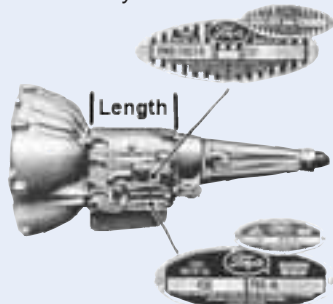

## Ford-O-Matic Transmission Shift Lever Parts

55-57 Shield, for shift selector dial light . . . B5S-15840-A 21.95



55-57 Gearshift lever pawl . . . . . B6S-7269-A 22.95

55-57 Gearshift lever knob, black plastic . . . B5S-7213-B 26.95



55-57 Gearshift lever bushing & washer kit . . . . . B5SZ-7A133-KT 10.95 kit

55-57 Gearshift lever neutral safety switch bracket, . . . . . FEA-15839-B 22.95

55-57 Gearshift lever pivot pin (not shown) . . . B5S-7241-A 8.95



55-57 Gearshift release rod (shown) . . . . . B5S-7489-A 6.95

55-57 Button assembly, includes chrome button with set screw, spring & retainer snap ring . . . . . B5S-77619-ASY 19.95

55-57 Spring, for chrome shift button . . . . . B5S-77619 2.95

55-57 Spring, for black plastic shift ball . . . B5S-77635-A 1.95

55-57 Screw, for shifter button . . . . . 89447-S 2.95

## Ford-O-Matic Transmission Parts

### Transmission Screen Kit



55-57  Includes screen & pan gasket . . . . . B9MP-7A098-KT 14.95 kit

### Gasket & Seal Kit

55-57 Gasket & seal kit . . . . . B9AZ-7153-MKT 45.95 kit

### Overhaul Kit

55-57 Overhaul kit, includes gaskets, seals, snap rings, clutches, plates & screen, automatic transmission . . . . . B5AZ-7C391-KT 128.95 kit

### Dipstick & Tube



55-57 Automatic transmission dipstick . . . B5AZ-7A020-A 27.95

55-57 Automatic transmission dipstick tube, with bracket . . . . . B6AZ-7A228-A 26.95

### Splash Shields

55-56 Splash shield, for linkage, air cooled transmission . . . . . B5S-7779 15.95

56-57 Splash shield, for linkage, water cooled transmission . . . . . B6S-7779 23.95

### Governor Inspection Cover Gasket

55-57 Gasket . . . . . C1VP-7B391-B 1.95

### Converter Parts

55-56 Gasket, impeller hub to impeller, air cooled transmission with aluminum converter impeller . . . . . 1P-7916 5.95

55-57 "O" ring, converter cover to impeller . . . B6A-7963 6.95

### Bell Housing Parts

56-57 Lower cover, water cooled Ford-O-Matic . . . . . B6A-7980-A 24.95

55-57 Front cover, with welded nut, Ford-O-Matic . . . . . COMM-7985-A 39.95

### Extension Housing Bushing & Seal



55-57 Automatic transmission extension housing bushing . . . . . B3TZ-7A034-A 5.95

55-57 Automatic transmission extension housing seal . . . . . C2AZ-7052-A 9.95

### Extension Housing Dust Shield



55-57  Automatic transmission . . . . . 8A-7053 19.95

### Pan Gasket

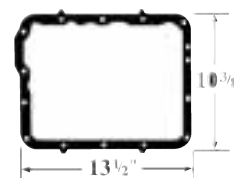

55-57 Automatic transmission pan gasket . . . . . B5SZ-7A191-A 3.95

### Manual Control Lever Oil Seal



55-57 Automatic transmission manual control lever oil seal . . . . . C7AZ-7B498-A 3.95

### Intake Manifold Bellcrank



1957 **Except** dual 4 bbl carbs, automatic transmission kickdown rod & accelerator linkage connect to this . . . . . B7SZ-7A185-A 86.95

Visit our Website:

[macsautoparts.com](http://macsautoparts.com)

Office/Technical:  
**(716) 210-1340**

Prices are each, unless otherwise noted.  
Prices subject to change without notice.



The cooling system is one of the hardest working systems on any vehicle. When you think about the constant heat & pressure of coolant flowing thru hot water jackets, rubber hoses, the water pump itself & the radiator, it's easy to understand how leaks & other failures are so common. Yet when it's working properly, our cooling system is often "out of sight & out of mind." Keep a close eye on the many components of the cooling system on your car & keep your friendly & reliable Ford engine cool & happy!

## Water Wetter

Is your engine running hot? Cool it off with Water Wetter®. Adding one 12 oz. bottle to 12-16 quarts of coolant can drop the operating temperature up to 30°. Not only that, you will also be reducing rust, corrosion & electrolysis in your cooling system. It's modern science for your classic car. Call us & place your order today!



ALL Water Wetter® 12 oz. bottle. . . . WET-H2O 9.95

## Radiators

- 55-57 **OS** Heavy duty, 4 row, without transmission oil cooler, for air cooled Ford-O-Matic or any manual transmission . . . . . B5S-8005-A 385.95
- 56-57 **OS** Heavy duty, 4 row, with transmission oil cooler, for water cooled Ford-O-Matic . . . . . B6S-8005-A 385.95

Want to know an easy way to test a radiator for a leak? Remove it from the car & get an old bicycle tube (large diameter works best). Cut the tube in half, put one end over the upper radiator hose neck & the other end over the low neck. Tighten hose clamps on each end, install the radiator cap & use the valve stem on the tube to pump in air from the air compressor. Then, put the radiator in one of those little baby wading pools. It works great!

## Radiator Cleaner



ALL Permatex heavy-duty radiator cleaner, 1 quart. . . . . RSP27 12.25

## Radiator Overflow Tubes



55-57 Stainless steel. . . . . B5S-8006-SS 20.95  
 55-57 Same as above, **except** steel. . . . . B5S-8006-A 14.95

## Radiator Cap



55-57 Original style AC #698 . . . . . B8A-8100-A 29.95

## Radiator Petcocks



55-57 1/4" pipe thread, straight outlet . . . 8A-8115 3.80

## Radiator Support Pad



55-57 Rubber block, approx. 2-7/8" long x 1-1/4" wide x 3/4" thick . . . AD-8125-B 4.95

## Fan Shroud & Parts

- 55-57 Upper fan shroud . . . . . B5S-8147-C 101.95
- 55-57 Lower fan shroud . . . . . B5S-8148-C 71.95
- 55-57 Upper fan shroud to radiator seal . . . . . B5S-8147-S 3.95
- 55-57 Upper fan shroud to radiator seal staple kit . . . . . B5S-8147-KT 0.95 kit



55-57 Lower fan shroud to radiator bracket. . . . . B5S-8149-B 12.95

## Radiator Hoses



- 55-57 Radiator hose set, upper & lower, with "FoMoCo" script . . . . . 8260-51 37.95 set
- 55-57 Upper radiator hose, with "FoMoCo" script. . . . . B5S-8260 20.95
- 55-57 Lower radiator hose, with "FoMoCo" script. . . . . B5S-8286 20.95
- 55-57 Upper radiator hose, molded, exact reproduction, no script. . . . . 8260-36921 14.95
- 55-57 Lower radiator hose, replacement, exact reproduction, with kink in top for exact fit, no script. . . . . 8286-36181 15.95

## Original Band-Type Hose Clamps



- 55-57 Hose clamp kit, includes 4 clamps, original band-type . . . . . B5S-8287-KT 2.95 kit
- 55-57 Hose clamp, lower, original band-type (2 required). . . . . B8261 1.00
- 55-57 Hose clamp, upper, original band-type (2 required). . . . . B8287 1.00





Water circulating throughout your engine is critical to its longevity. Don't take a chance on an "iffy" water pump, choose from our complete selection of new or remanufactured pumps & get that water moving to keep your engine cool! All of the water pumps listed below include the mounting gaskets.

**Water Pumps**



- 55-57 Water pump, with mounting gaskets, new . . . . . B6A-8501-B 85.95
- 55-57 Water pump, with mounting gaskets, rebuilt (see core note below). . . . . B6A-8501-BR 68.95

**CORE EXCHANGE NOTE**

The rebuilt water pump above is sold on an exchange basis. A core fee of \$20.00 will be charged if your core is not received before we ship. Core fee will be refunded if an acceptable exchange is received in the supplier's original package within 90 days of purchase.

**Fan Belts**

The reproduction belts are concours-correct with original-type features. The replacement belts function properly, but do not look original.

**Replacement**

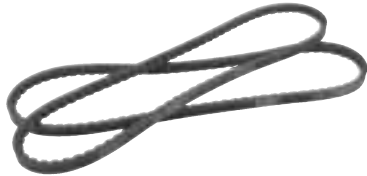

- 55-57 Fan to generator belt, for cars without AC . . . . . 8620-10748 11.95
- 55-57 Power steering belt, for cars without AC . . . . . 8620-10748 11.95

**Reproduction**

- 55-56 Fan belt, notched, for cars originally with 3 blade fan . . . . . 8620-A 23.95
- 56-57 Fan belt, notched, for cars originally with 4 blade fan . . . . . 8620-B 23.95
- 1957 Fan belt, without notches, for late 1957 models with 4 blade fan . . . . . 8620-BL 23.95
- 55-56 Power steering belt, notched, used thru early 1956 . . . . . 8620-C 23.95
- 56-57 Power steering belt, notched, used from mid 1956-mid 1957 . . . . . 8620-D 23.95
- 1957 Power steering belt, without notches, used only in late 1957 . . . . . 8620-DL 23.95

**Fan Belt Dressing**

- ALL  Belt dressing, adds to belt life & helps increase performance, 5 oz. spray can . . . . . RSP10 \* 3.95



\* **HAZARDOUS MATERIAL** can only be shipped by ground/surface within the U.S. because of government regulations.

**Water Pump Baffle**



- 55-57 Helps prevent overheating, insert between water pump spacer & front timing case cover, stainless steel. . . . . B5A-8502-SS 22.95

**Water Pump to Block Gasket (2 required)**



- 55-57 Water pump to block gasket . . . . . B5A-8507-A 2.95

**Water Pump Pulley**

- 55-57 Original for 55-56 but will work on 1957. . . . . B5S-8509-B 103.95

**Water Pump Pulley to Fan Spacer**



- 55-57 1.28" thick . . . . . B5S-8546-A 15.95

**Water Bypass Tube & Gasket**

- 55-57 Bypass tube . . . . . C2TZ-8548-A 10.95
- 55-57 Water bypass tube gasket. . . . . EAN-8563-B 0.95

**Thermostats, Gasket & Housing**



- 55-57 Thermostat, 180°, gasket not included. . . . . C2AZ-8575-A 5.95
- 55-57 Thermostat, 160°, gasket not included. . . . . C2AZ-8575-B 5.95
- 55-57 Thermostat gasket . . . . . B5A-8255-A 1.95
- 55-57 Thermostat housing . . . . . B5S-8592-A 43.95

**Water Temperature Sending Units & Adapters**



- 1955 Sending unit, 6 volt . . . . . 8A-10884 49.50
- 1956 Sending unit, 12 volt . . . . . B6C-10884-A 55.95
- 55-56  Adapter . . . . . B4A-10911-A 14.95
- 1957 Sending unit, 12 volt . . . . . B7A-10884-A 9.95
- 1957 Adapter (not shown) . . . . . B7A-10911-A 14.95



If you've converted your '55 Bird to 12 volts, substitute our B6C-10884-A water temperature sender so your dash gauge will function.



## Gas Tanks & Parts



- 1955 Gas tank (shown) . . . . . B5S-9002-DR 259.95
- 1956 Gas tank . . . . . B6S-9002-AR 259.95
- 1957 Gas tank . . . . . B7S-9002-AR 259.95
- 55-56 Pad, rubber, fits between the gas tank & the trunk floor (12 required) . B5S-9A068 1.95
- 1957 Pad, rubber, fits between the gas tank & the trunk floor (6 required) . . B5S-9A068 1.95



- 55-56 Gas tank filler neck grommet (shown) . . . B7A-9080-A 6.95
- 1957 Gas tank filler neck "O" ring . . . . . 370322-S 2.95
- 1957 Gas tank filler neck to quarter panel bracket . . . . . B7S-9034-BRKT 12.95
- 1957 Gas tank vent hose & clamps kit . . . . . B7S-9170-A 2.95 kit

## Gas Tank Straps & Hardware

- 1955 Gas tank strap (2 required) . . . . . B5S-9092 14.95
- 1956 Gas tank strap (2 required) . . . . . B6S-9092-A 14.95
- 1957 Gas tank strap (2 required) . . . . . B7A-9092-B 16.95
- 55-57 Pad, fits between the gas tank & the straps . . . . . B5S-9092-PR 3.95 pair



- 55-56 Gas tank strap bolt, loop at one end (2 required) . . . . . B5SZ-9A010-A 5.95
- 1957 Gas tank strap bolt, "J" hook (2 required) . . . . . B7SZ-9A010-A 5.95

## Gas Tank Caps



- 1955 Gas tank cap, exact reproduction . . . . . B5S-9030-A 26.95
- 1956 Gas tank cap, exact reproduction . . . . . B6S-9030-A 25.95
- 1957 Gas tank cap, exact reproduction . . . . . B7S-9030-A 25.95

## Gas Tank Sealer

Put a stop to rust, leaks & corrosion permanently. Resistant to all fuels including phase II oxygenated fuels & alcohol. With its ability to bond to metal or fiberglass it can be used in a multitude of applications. Our 1-quart can is enough to treat several tanks.



- ALL Gas tank sealer, 1 quart . . . . . RSP22A \* 24.25 quart

## Gas Tank Sending Unit Floats



- 55-56 Brass, for original sending units . . . . . 01A-9202 8.95



- 55, 57 Special solid design by Stewart-Warner, works on 99A-9275 or B7A-9275-FR sending units . . . . . COAZ-9202-SW 11.95
- 55, 57 Brass, works on 99A-9275 or B7A-9275-FR sending units . . . . . COAZ-9202-B 4.95

## Gas Tank Sending Units



- 1955 6 volt, universal type, includes gasket & complete adjustment instructions (uses replacement float COAZ-9202-B or COAZ-9202-SW listed above) . . . . . 99A-9275 34.95
- 1956 12 volt, replacement type, includes cork gasket (replacement float not available) . . . . . B6A-9275-A 83.95



- 1957 12 volt universal type, includes gasket & complete adjustment instructions (uses replacement float COAZ-9202-B or COAZ-9202-SW listed above) . . . . . B7A-9275-FR 67.95

## Gas Tank Sending Unit "O" Rings & Lock Ring



- 55-56 Gas tank sending unit gasket, cork . . . . . 68-9276 1.50
- 55-56 Gas tank sending unit gasket, neoprene . . . . . 68-9276-N 1.95
- 1957 Gas tank sending unit "O" ring (not shown) . . . . . B9AF-9276-A 2.95
- 1957 Gas tank sending unit lock ring . . . . . B7A-9277-A 9.95

## Fuel Stabilizer

The ideal formulation to add to the gas tank when storing vehicles for extended periods. It not only prevents varnish & tank corrosion, it has a no alcohol formula & will not attack rubber lines or diaphragms as many other fuel stabilizers do.

- ALL 1 quart can, 1 oz. of this product will keep 3 gallons of fuel fresh for at least 3 years . . . . . RSP101 \* 28.95 quart



\* **HAZARDOUS MATERIAL** can only be shipped by ground/surface within the U.S. because of government regulations.



**Gas Tank Filler Door Hinges, Springs & Bumpers**



- 55-56 Gas tank filler door hinge . . . . . B5S-4040635-A 47.95
- 1957 Gas tank filler door hinge . . . . . B7S-4040635-A 47.95



- 55-56 Gas tank filler door spring (2 required) . . . . . B5S-16377-A 4.95
- 1957 Gas tank filler door spring (2 required) . . . . . B7S-16377-A 4.95



- 55-56 Gas tank filler door bumpers . . . . . 357170-APR 3.95 pair
- 1957 Gas tank filler door bumpers . . . . . 357170-BPR 3.95 pair

**Fuel Filter Clip & Bracket**

- 55-57 Fuel line clip, for fuel filter bracket . B5TZ-9B281-A 2.95



- 55-57 Fuel filter bracket . . . . . B5S-9180-A 7.95

**Fuel Pump & Gasket**



- 55-57 Dual action, new, includes gasket. . . . B5S-9350-B 66.95
- 55-57 Gasket, for glass bowl on original fuel pump . . . . . A9173 0.35

**Fuel Pump Mounting Gasket**



- 55-57 Fuel pump mounting gasket . . . . . C3AZ-9417-C 1.95

**Fuel Filter Element Only**



- 55-57 Fuel filter, for in line glass bowl filter, includes rubber gasket . . . . . B7S-9365-B 9.95

**Fuel Filters**



- 55-57 Fuel filter with glass bowl, in-line type, does not have domed top like original . . . . . B7S-9155-A 20.95
- Do you also want an in-line fuel filter for your car? Our in-line fuel filter fits every car. Just plumb it into your fuel line & protect your carb from dirt & other contaminants.*



- ALL In-line type, includes hoses & clamps . . . . . C2RZ-9155-H 6.95

**Fuel & Vacuum Line Sets**

- 1955 4-piece set, OE steel . . . . . B5S-9369-OE 43.95 set
- 1955 4-piece set, stainless steel . . B5S-9369-SS 59.95 set
- 1956 4-piece set, OE steel . . . . . B6S-9369-OE 43.95 set
- 1956 4-piece set, stainless steel . . B6S-9369-SS 59.95 set
- 1957 4-piece set, OE steel, **except "E"** code 312 with dual 4 bbl carbs or "F" code supercharged 312. . . . . B7S-9369-OE 43.95 set
- 1957 4-piece set, stainless steel, **except "E"** code 312 with dual 4 bbl carbs or "F" code supercharged 312. . . . . B7S-9369-SS 59.95 set

**Fuel Pump to Carburetor Fuel Lines**



- 56-57 Fuel pump to carburetor fuel line . . . . B6S-9369-A 34.95



- 1957 Fuel pump to carburetor fuel line, 4 pieces, E-code 312 V-8 with two 4 bbl carburetors . . . . . B7S-9369-B 36.95

**Flexible Fuel Line**

- 55-57 From main line to pump . . . . . 1A-9288 7.95

**Fuel Line Hose**



- ALL 1/4", rubber, sold by the foot . . . . B-9272-A 1.00 foot
- ALL 5/16", rubber, sold by the foot . . . B-9272-B 1.05 foot
- ALL 3/8", rubber, sold by the foot . . . . B-9272-C 1.15 foot





## Carburetor Base Gaskets

1955	Carburetor base to manifold gasket set, 3 pieces . . . . .	B5S-9447-SET	5.95 set
1956	Carburetor base to manifold gasket . . .	B6A-9447-A	2.95
1957	Carburetor base to manifold gasket (2 required) . . . . .	C2AZ-9447-E	2.95

## Carburetor Dashpot Bracket

1957	Carburetor dashpot bracket . . . . .	B7S-9B550-B	21.95
------	--------------------------------------	-------------	-------

## Carburetor Tune-up Kits



1955	Carburetor tune-up kit, 4 bbl carburetor, does not include secondary diaphragm (listed below), <b>Motorcraft</b> . . . . .	B5A-9590-KT	50.95 kit
1956	Carburetor tune-up kit, 4 bbl carburetor, does not include secondary diaphragm, (listed below), <b>Motorcraft</b> . . . . .	B6A-9590-KT	43.95 kit
1957	Carburetor tune-up kit, does not include secondary diaphragm (listed below), use 1 kit for 4 bbl carburetor with supercharger, use 2 kits for dual 4 bbl carburetor setup, <b>Motorcraft</b> (as required) . . . . .	B6A-9590-KT	43.95 kit

## Carburetor Secondary Vacuum Diaphragms



55-56	For Holley 4000 4 bbl carburetors . . .	EBY-9503-A	29.95
1957	For Holley 312 4 bbl 4150 . . . . .	B7A-9503-B	8.95

## Accelerator Pump Piston Cup



55-56	Rubber, 4 bbl Holley 4000 . . .	B5A-9572-A	4.95
-------	---------------------------------	------------	------

## Choke Housing to Carburetor Rod

1955	Choke housing to carburetor rod . . .	B5SZ-9A599-A	15.95
------	---------------------------------------	--------------	-------

## Fuel Line Inlet Parts

55-56	Fuel line inlet fitting, includes nylon gasket, Holley 4000 "teapot" carb . . . . .	B2TZ-9A520-A	19.95
55-56	Fuel line inlet gasket, nylon, Holley 4000 "teapot" carb . . . . .	C2AZ-9229-A	1.95
55-56	Fuel line inlet screen, Holley 4000 "teapot" carb . . . . .	A8Q-9938	6.95

## Fuel Line Fitting Sealer



ALL	"High Tack," put this non-hardening sealer directly on threads to prevent leaks, 4 oz. can . . . . .	RSP25 *	5.45
-----	------------------------------------------------------------------------------------------------------	---------	------

## Primary Throttle Rod & Parts

55-56	Primary throttle rod, does not include lever, Holley 4000 "teapot" carb . . . . .	B5A-9581	75.95
55-56	Primary throttle rod bushing set, 5 pieces, Holley 4000 "teapot" carb .	B5A-9518-ST	20.95 set
55-56	Primary throttle rod screw set, 8 pieces, for throttle plates, Holley 4000 "teapot" carb . . . . .	B9A-9586-ST	5.95 set

## Carburetor Choke Cover Gaskets

1955	Gasket, choke housing to manifold . .	EAD-9853-B	1.95
55-56	Gasket, choke cover . . . . .	B6A-9871-A	1.95
1957	Gasket, choke cover, <b>except</b> supercharged 312 or 312 with two 4 bbl carbs . . . . .	B7A-9871-B	1.95
1957	Gasket, choke cover, supercharged 312 or 312 with two 4 bbl carbs . . . . .	B6A-9871-A	1.95

## Carburetor Choke Shields



1956	Carburetor choke shield . . . . .	B6A-9861-A	11.95
1957	Carburetor choke shield, 312 with supercharger . . . . .	B6A-9861-A	11.95

\* **HAZARDOUS MATERIAL** can only be shipped by ground/ surface within the U.S. because of government regulations.



**Air Cleaner & Parts**



- 55-56 Air cleaner assembly with chrome top, correct style for '56, will work on '55 (shown) . . . . . B6S-9600 285.95
- 55-56 Air cleaner cover gasket . . . . . B5SZ-9673-A 2.95
- 1955 Air cleaner carburetor stud . . . . . B5SZ-9A659-A 11.95
- 55-57 Air cleaner to hood seal, rubber & cork . . . 9600A 3.95
- 55-57 Air cleaner cork seal staple kit . . . . . 9600S 0.95 kit



- 55-57 Air cleaner wing nut, zinc plated . . . . . 358871-S36B 1.95
- 55-56 Air cleaner wing nut, chrome . . . . . 5556-CWN 3.95
- 1957 Air cleaner wing nut, chrome . . . . . 1957-CWN 3.95

**Carburetor Top Gaskets To Air Cleaner**

- 55-56 Carburetor top gasket to air cleaner . . . . . B5S-9654-A 2.95
- 1957 Carburetor top gasket to air cleaner . . . . . B7S-9654-A 1.95

**Automatic Choke Housing Gasket**

- 1955 Automatic choke housing gasket . . . . . EAD-9853-B 1.95

**Accelerator Pedal, Rod & Seal**



- 55-57 Accelerator pedal . . . . . B5A-9735-A 10.95



- 55-57 Accelerator pedal rod (shown) . . . . . B5S-9727-A 8.95
- 55-57 Accelerator pedal rod seal, at firewall . . . . . B5S-9727-SEAL 1.95

**Accelerator Pedal Bellcranks**

- 55-56 At firewall, all 1955, 1956 manual transmission only (not shown) . . . . . B5S-9725-A 67.95



- 1957 Mounted on intake manifold, **except** with dual 4 bbl carbs, automatic transmission kickdown rod connects to this . . . . . B7SZ-7A185-A 86.95
- 56-57 At firewall, automatic transmission . . . . . B7S-9725-B 66.95

**Throttle Return & Kickdown Springs**

- 55-56 Throttle return spring . . . . . B9A-9737-C 4.95
- 1957 Throttle return spring, Ford-O-Matic . . . B7S-9737-B 5.95
- 1957 Throttle return spring, 2x4 bbl carburetor set-up . . . . . B7S-9737-C 5.95
- 55-57 Throttle kickdown spring, **Ford-O-Matic** . . . . . B5S-9736-A 5.95

**Accelerator Rod to Floor Seal**



- 55-57 Seal . . . . . BA-9738-S 2.95

**Accelerator Rods**

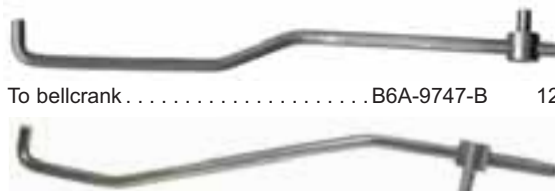

- 1956 To bellcrank . . . . . B6A-9747-B 12.95

- 1957 To kickdown, **Ford-O-Matic** . . . . . B7S-9747-B 11.95

**Automatic Choke Control Tubes, Insulators & Parts**

- 1955 Automatic choke control tube, inlet . . . B5A-9820-B 10.95



- 1955  Automatic choke heat tube, fits inside chamber (shown) . . . . . B4A-9890-A 9.95
- 1956 Automatic choke control tube, outlet, with fittings . . . . . B6A-9819-A 5.95
- 1956 Automatic choke control tube, inlet . . . B6A-9820-A 19.95
- 1956 Automatic choke control tube insulator . . . . . B6A-9865-A 3.95
- 56-57 Automatic choke control tube elbow, inlet, brass . . . . . ECU-9877-A 10.95
- 56-57 Automatic choke control tube elbow, outlet, brass . . . . . ECU-9884-A 10.95
- 56-57 Automatic choke heat control tube . . . B6A-9890-A 14.95
- 1957 Automatic choke control tube, outlet, with fittings . . . . . B7A-9819-B 5.95
- 1957 Automatic choke control tube insulator, V-8 292 with 2 bbl carburetor . . . . . ECG-9865-C 4.95
- 1957 Automatic choke control tube insulator, 4 bbl carburetor . . . . . B7A-9865-A 3.95
- 1957 Automatic choke heat control tube, 2x4 bbl carburetor set-up . . . . . B7A-9890-A 14.95
- 1957 Automatic choke air intake deflector mushroom . . . . . B7A-9492-A 9.95



## POWERGEN

Your friends will be fooled. They'll wonder why your headlights don't dim at idle. Tell them you have a secret. Tell them you stuffed an alternator into your generator housing. Tell them you have PowerGen—75 amps at highway speeds but, most importantly, 60 big amps at idle! This is the new way to go – the reliability of an alternator with the classic look of a stock generator. For 12 volt systems.



- 55-57 PowerGen, with offset left hinge mount, painted black . . . . . 10346-82101 374.95
- 55-57 PowerGen, with offset left hinge mount, polished aluminum (shown) . . . . . 10346-282101 425.95

## Remanufactured Generator & Conversion Kits

Our remanufactured generator is sold on an exchange basis. Your rebuildable core must be returned in the same box that the replacement unit arrives in. The **core fee of \$20.00** will be refunded if an acceptable exchange is received within 90 days of the purchase date. Our generators do not include a pulley. Sorry, pulleys are not presently available from MAC's.



- 56-57 30 amp . . . . . B6A-10002-A 99.95  
*The 1956 & '57 T-Bird had a unique generator endplate. We are proud to announce that we now carry conversion kits so you can have a "correct" looking generator that mounts just like the original did.*
- 56-57 Conversion kit, for generator with cast end plate, instructions included . 10211-CAST 22.95 kit
- 56-57 Conversion kit, for generator with stamped steel end plate, instructions included . . . 10211-STAMPED 22.95 kit

## Ford Design Generator Parts

- 56-57 Generator armature, 30 amp . . . . . C1TZ-10005-A 24.95
- 56-57 Generator rear end plate & brush assembly . . . . . C3AZ-10050-A 16.95



- 55-57 Generator brush spring (2 required) . . . . . 91A-10057 3.35
- 56-57 Generator brush set . . . . . C1AZ-10069-A 6.95 set



- 55-57 Generator front bearing . . . . . 8BA-10094 11.95
- 55-57 Generator rear bearing . . . . . B6A-10095-B 11.95
- 55-57 Generator bolt, 1/4"-20 x 6-9/16" long (as required) . . . . . C3AZ-10120-A 3.95
- 56-57 Generator front end plate . . . . . B6A-10139-B 8.95
- 56-57 Field coil assembly . . . . . B6AZ-10175-D 19.95

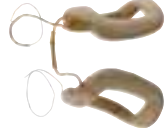

## Generator Belt Adjustment Arm



- 55-57 Generator belt adjustment arm . . . . . B6S-10145-A 13.95

## Generator Mounting & Support Brackets



- 55-57 Cast mounting bracket . . . . . B5SZ-10151-A 39.95
- 55-57 Generator support bracket . . . . . B5SZ-10153-A 7.95

## Generator Overhaul Kits

Give yourself peace of mind knowing that a burned out bearing or worn out brushes aren't going to leave you stranded out on the road—install a new set of brushes & front & rear bearings today!



- 56-57 Includes one each of the following: C1AZ-10069-A brush set, 8BA-10094 front bearing, B6A-10095-B rear bearing & 2 each of 91A-10057 brush springs. . . . . COAZ-10000-KT 30.95 kit
- 56-57 Includes one each of the following: C1AZ-10069-A brush set, 8BA-10094 front bearing & B6A-10095-B rear bearing . . . . . C2AZ-10000-KT 24.95 kit

**BUY a KIT & SAVE**

## Generator Rebuild Kits

If you need to go beyond new brushes & bearings, we can help. Check out the two rebuild kits listed below.



- 56-57 Rebuild kit, includes one each of the following: C1AZ-10069-A brush set, 8BA-10094 front bearing, B6A-10095-B rear bearing & C1TZ-10005-A armature . . . . . B6A-10002-KT 44.95 kit
- 56-57 Major rebuild kit, includes one each of the following: C1AZ-10069-A brush set, 8BA-10094 front bearing, B6A-10095-B rear bearing, C1TZ-10005-A armature & B6AZ-10175-D field coil . . . . . B6A-10002-MKT 59.95 kit

**BUY a KIT & SAVE**

## Alternator Installation Kit

This kit features a rebuilt 12 volt, 115 amp alternator. The pulley is installed & all the necessary mounting brackets & hardware are included. Just follow the easy step-by-step directions & you are well on your way to a steady, consistent charging system. Call for yours today!



- 55-57 12 volt negative ground, includes pulley for the narrow belt, brackets & mounting hardware, 292 & 312 V-8 . . . . . B5S-10346-KT 209.95 kit





**Voltage Regulators**



- 1955 6 volt, 30 AMP, blue cover. . . . . 8A-10505 41.95
- 56-57 12 volt, 25 or 30 AMP,  
black cover . . . . . C3TZ-10505-B 38.95

**Original-Type Script Batteries**

*What item under the hood do classic car owners most often overlook? You're right, it's the battery. We now have the perfect addition to keep your classic "period correct." From the early "tar top" style to the later embossed hard rubber case batteries, we have them all. Call us today & we'll be happy to send one right to your door! All batteries are heavy-duty. They are shipped "Damp-Dri" from the factory & can be shipped by UPS. You provide the electrolyte, which you can purchase locally. A \$45.00 shipping fee applies whether shipped to you or picked up at our store.*

**All batteries can only be shipped by ground/surface within the U.S. because of government regulations.**



- 1955 6 volt, Group 2N, 660 cold cranking amps, "Power Punch" embossed on front, 10-1/4" x 5-1/2" x 9", hard top with red battery caps. . . . . 2N-POWERPUNCH 280.95
- 56-57 12 volt, Group 29N, 585 cold cranking amps, "Power Punch" embossed on front, 12-1/2" x 5-1/2" x 9", tar top with red battery caps (shown). . . . . 29N-POWERPUNCH 280.95
- 56-57 12 volt, Group 32N, 610 cold cranking amps, "Power Punch" embossed on front, 14" x 5-1/2" x 9", hard top with yellow battery caps . . . . . 32N-POWERPUNCH 304.95

**Battery Trays**



- 1955 For Group 2N 6 volt battery only, includes nuts welded into brackets . . . . . B5S-10732-A 69.95
- 56-57 For Group 29N or Group 32N 12 volt battery . . . . . B6S-10732-B 69.95

**Battery Mat**

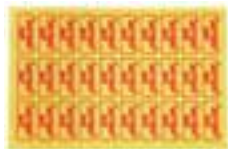

- ALL  Battery mat, absorbs & neutralizes battery acid & vapors, 8" x 12", trim to fit . . . . .BATMAT 5.95

**Battery Hold-Down Clamps**

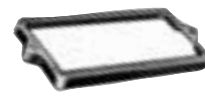

- 1955 Use with Group 2N battery . . . . . B4A-10718-A 11.95
- 56-57 Use with Group 29N 12 volt battery . . B6A-10718-C 20.95
- 56-57 Use with Group 32N battery, rubber coated steel NOS Ford . . . . . B6AZ-10718-B 33.95
- 56-57 Use with Group 32N battery, all steel 3-hole type hold-down . . B6AZ-10718-BR 22.95



**Battery Post Corrosion Arrestors**



- ALL  They absorb & neutralize battery acid . . . . . C1AZ-10A717-B 2.95 pair

**Battery Hold-Down Clamp Kits**

*All kits include the hold down clamp, hold down bolts, wing nuts & washers*

- 1955  For original style 6 volt Group 2N battery. . . . . B5S-10718-KT 21.95 kit
- 56-57  For original style Group 29N battery . . . . . B6S-10718-AKT 31.95 kit
- 56-57  For Group 32N heavy-duty battery, with 3 hole type hold down. . . . . B6S-10718-BKT 30.95 kit

**Battery Hold-Down Wing Nuts & Washers**

- 1955 Nut & washer set, includes 2 original type cast wing nuts, 2 metal washers & 2 rubber washers . . . B5S-10756-ST 3.95 set
- 56-57 Nut & washer set for Group 29N battery, includes 2 original type pressed wing nuts, 2 metal washers & 2 rubber washers. . . . . B6S-10756-AST 4.95 set
- 56-57 Nut & washer set for Group 32N battery, includes 3 original type pressed wing nuts, 3 metal washers & 3 rubber washers. . . . . B6S-10756-BST 4.95 set

**Battery Hold-Down Bolts**



- 1955 With Group 2N battery (2 required) . . . B5A-10756-B 1.95
- 56-57 With Group 29N battery, use at rear of battery. . . . . B6S-10756-A 4.95
- 56-57 With Group 29N battery, use at front of battery . . . . . B5A-10756-B 1.95
- 56-57 With Group 32N battery (3 required) . . B5A-10756-B 1.95

**Battery Hold-Down to Inner Fender Panel Bracket**



- 1955 Battery hold-down to inner fender panel bracket. . . . . B5S-10721-A 5.95



## Battery Heat Shields

1955	Heat shield	B5S-10757-A	32.95
56-57	Heat shield	B6S-10757-A	41.95

## Battery Disconnects & Bracket



ALL	Battery disconnect, mounts at battery post, a simple knob turns it on or off	A14300C	12.85
ALL	Battery disconnect, remote mount so it's hidden from view	A14300D	24.75
ALL	Bracket, for remote mount battery disconnect	A14300DB	7.50

## Reproduction Battery Cables & Sets

All terminals, boots, heads & mouldings have been duplicated to precise detail. The wire insulation is original neoprene rubber. The sets include positive, negative & starter cables. A ground strap was also used at the back of the engine head. These are not included in the sets – they are listed directly below the battery cable sets.

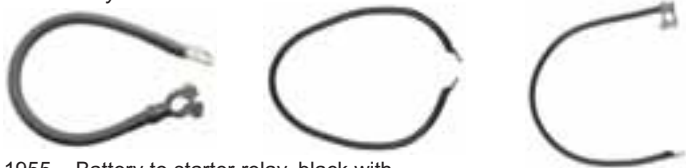

1955	Battery to starter relay, black with brass plated ends (shown)	B5S-14300-A	22.95
1955	Starter relay to starter, black with brass plated ends (shown)	B5S-14431-A	23.95
1955	Battery to ground, black with brass plated ends (shown)	B5S-14301-A	29.95
56-57	Battery to starter relay, black with brass plated ends	B6S-14300-B	19.95
56-57	Starter relay to starter, black with brass plated ends	B6S-14431-B	17.95
1956	Battery to ground, black with brass plated ends	B6S-14301-B	18.95
1957	Battery to ground, black with brass plated ends	B6S-14301-C	19.95

Cable sets include a battery to starter relay cable, a starter relay to starter cable & a battery to ground cable.



1955	All three of the needed cables listed above (shown)	B5S-14300-ST	71.95 set
1956	All three of the needed cables listed above	B6S-14300-ST	53.95 set
1957	All three of the needed cables listed above	B7S-14300-ST	53.95 set



55-56	Ground strap, engine to firewall, original type	8M-14303	5.95
1957	Ground strap, engine to firewall, original type	FEJ-14303-A	11.95

## Reproduction Starter Cable Brackets & Grommets

Original routing of the starter cable is: from the relay to a bracket on the firewall, then to another bracket on the bell housing, then to the starter. These bracket & grommet sets allow you to duplicate this original routing.

55-56	Battery cable bracket, on bell housing	B5S-14304-B	5.95
55-56	Battery cable bracket, on firewall	B5S-14304-F	5.95
55-56	Grommet for battery cable bracket	B5S-14302	5.95



1957	Starter cable bracket & grommet, mounts on bell housing	B7S-14431-B	7.95
------	---------------------------------------------------------	-------------	------



1957	Starter cable bracket & grommet, mounts on firewall	B7S-14431-F	7.95
1957	Grommet for battery cable bracket (2 required)	B7S-14302	4.95

## Voltage Reducers

Made by Runtz, these will reduce a 12 volt input to 6 volts so you can safely use your original 6 volt dash gauges.



32-55	Reduces 12 to 6 volt, designed for gauges, 1 amp maximum, comes with detailed instructions, 1 per gauge, actually mounts onto the gauge itself, allowing you to run several in a row	V12872	14.95
-------	--------------------------------------------------------------------------------------------------------------------------------------------------------------------------------------	--------	-------



1955	Reduces voltage from 12 volts to 6 volts, maximum load is 4 amps	V12873	11.75
------	------------------------------------------------------------------	--------	-------



1955	Reduces voltage from 12 volts to 6 volts, maximum load is 6 amps	V12874	23.25
------	------------------------------------------------------------------	--------	-------



*Have you ever thought about the incredible torque thrust & wear that a typical starter motor must go thru to start an engine? The starter drive unit must thrust the starter gear out to mesh perfectly with the teeth on the ring gear of your flywheel & then the small electric motor must spin over the crankshaft, pushing all those pistons up against compression. It's even worse on high performance or large cubic inch engines. Give your old starter a break. Replace it with a guaranteed top-quality starter motor.*



**Starter Motor**



56-57 12 volt, 3 bolt mount, includes starter drive. . . . . B6A-11002-A 114.95

*Our starter listed above is sold on an exchange basis. A core fee of \$20.00 will be charged if your core is not received by the shipping date. The core fee will be refunded if an acceptable exchange is received within 90 days of purchase date. Your core must be returned in the original box.*

**Starter Drive**



55-57 Starter drive. . . . . C1AZ-11350-A 43.95

**Starter Parts**

55-57 Armature thrust washer. . . . . 18-11036 0.95



55-57 Brush end plate bushing. . . . . 18-11052 1.15



55-57 Brush set (shown) . . . . . 18-11057 5.75 set

55-57 Cover band . . . . . B1TZ-11126-A 5.95

55-57 Drive end plate & bushing. . . . . C2AZ-11130-A 16.95

55-57 Drive end housing bushing, 5/8" ID x 13/16" OD x 1-15/32" long (shown) . . . . . 1CM-11135-A 3.95



55-57 Post repair kit (above right). . . . . A9AZ-11102-B 6.95 kit

*The starter relay, or solenoid of Ford electrical systems is usually located right in plain sight, at the top of the passenger side of the engine bay. This makes it very convenient for service work. This also makes it the frequent target of judges & Ford admirers who might tend to look into your engine compartment when you have the hood raised at a car show. Like any starter relay, Ford units work hard over many years of start-up sequences, consequently, many of them have finally worn out & need to be replaced.*



**Reproduction Starter Relay**



56-57  12 volt, correct brown body, letters & markings & all hardware . . . . . B7A-11450 44.95

**Replacement Style Starter Relays**



1955  6 volt, replacement style . . . . . B5A-11450-A 29.95



56-57 12 volt, replacement style . . . . . B6A-11450-A 11.95





## “The Ignitor”® Points & Condenser Replacements

Never fight with another set of points again! Install “The Ignitor” by Pertronix, the breakerless electronic ignition module. Get longer plug life, better fuel economy & increased horsepower. For best results, use with “Flame Thrower” ignition coils.



- |       |                                                                                                              |               |       |
|-------|--------------------------------------------------------------------------------------------------------------|---------------|-------|
| 55-56 | The Ignitor, only operates on a negative ground 12 volt system . . .                                         | 12127-1282    | 79.95 |
| 55-56 | The Ignitor, only operates on a 6 volt positive ground system. . . .                                         | 12127-1282-P6 | 88.95 |
| 1957  | The Ignitor, only operates on a negative ground 12 volt system <b>except</b> dual point distributor. . . . . | 12127-1281    | 75.95 |

## “Flame Thrower”® Ignition Coils

This high-performance 40,000-volt ignition coil is the best coil to use with our Pertronix Ignitor breakerless points & condenser replacement.

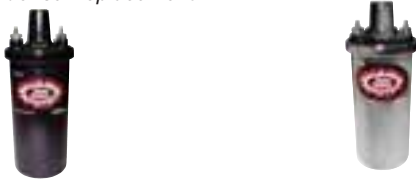

- |       |                                      |             |       |
|-------|--------------------------------------|-------------|-------|
| 55-57 | Black, for 12 volt system . . . . .  | 12029-40011 | 34.95 |
| 55-57 | Chrome, for 12 volt system . . . . . | 12029-40001 | 38.95 |

## Ignition Coils



- |       |                                               |              |       |
|-------|-----------------------------------------------|--------------|-------|
| 1955  | Black, 6 volt. . . . .                        | A12000       | 19.45 |
| 1955  | Black body with beige top, 6 volt . .         | 8BA-12029-MT | 22.95 |
| 56-57 | Black, 12 volt. . . . .                       | B6A-12029-B  | 21.95 |
| 1957  | Black body with mustard top, 12 volt. . . . . | B6A-12029-MT | 53.95 |

## Ignition Coil Mounting Strap



- |       |                                        |             |       |
|-------|----------------------------------------|-------------|-------|
| 55-57 | Ignition coil mounting strap . . . . . | B6A-12043-A | 14.95 |
|-------|----------------------------------------|-------------|-------|

## Ignition Coil Resistors

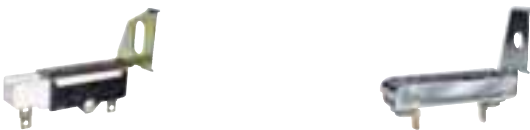

- |       |                                                                              |              |       |
|-------|------------------------------------------------------------------------------|--------------|-------|
| 56-57 | Ignition coil resistor . . . . .                                             | B7A-12250-A  | 17.95 |
| 56-57 | Ignition coil resistor, reproduction with original cadmium plating . . . . . | B7A-12250-AR | 24.95 |

## Spark Plug (8 required)



- |       |                                               |         |      |
|-------|-----------------------------------------------|---------|------|
| 55-57 | 18mm, <b>Motorcraft</b> replacement . . . . . | 12405-H | 2.95 |
|-------|-----------------------------------------------|---------|------|

## Reproduction Spark Plug Wire Sets

MAC's reproduction spark plug wires are correct in every way. Constructed with a wire core like the original. They feature spark plug boots with the “FoMoCo” oval molded in & have the proper protective conduit installed. The coil wire carries the proper number stamp & is the correct brown color.

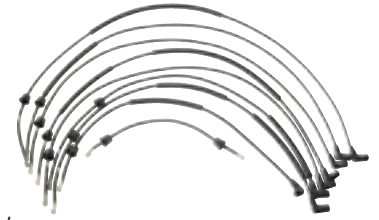

- |       |                                                |           |           |
|-------|------------------------------------------------|-----------|-----------|
| 55-56 | Spark plug wire set (shown) . . . . .          | 12259-AST | 71.95 set |
| 1957  | Spark plug wire set . . . . .                  | 12259-BST | 71.95 set |
| 55-57 | Spark plug wire protective conduit set . .     | 12110-ST  | 5.95 set  |
| 55-57 | Ignition coil wire, brown as original. . . . . | 12298-A   | 23.95     |

## Spark Plug Wire Shield (4 required)



- |       |                                  |             |      |
|-------|----------------------------------|-------------|------|
| 55-57 | Spark plug wire shield . . . . . | B5A-12299-A | 6.95 |
|-------|----------------------------------|-------------|------|

## Spark Plug Wire Grommets & Brackets



**BUY a KIT & SAVE**

- |       |                                                                                                     |              |           |
|-------|-----------------------------------------------------------------------------------------------------|--------------|-----------|
| 55-57 | Spark plug wire grommet & bracket kit, 11 pieces, contains all of the required items below. . . . . | FAA-12113-KT | 26.95 kit |
|-------|-----------------------------------------------------------------------------------------------------|--------------|-----------|



- |       |                                                                     |             |      |
|-------|---------------------------------------------------------------------|-------------|------|
| 55-57 | Spark plug wire clamp bracket, use with FAA-12361-A clamp . . . . . | FAC-12111-A | 5.95 |
|-------|---------------------------------------------------------------------|-------------|------|

- |       |                                                                     |             |      |
|-------|---------------------------------------------------------------------|-------------|------|
| 55-57 | Spark plug wire grommet bracket, square type (2 required) . . . . . | FAA-12112-A | 3.95 |
|-------|---------------------------------------------------------------------|-------------|------|

- |       |                                                |             |      |
|-------|------------------------------------------------|-------------|------|
| 55-57 | Spark plug wire grommet, in-line type. . . . . | FAC-12112-A | 3.95 |
|-------|------------------------------------------------|-------------|------|



- |       |                                                                      |             |      |
|-------|----------------------------------------------------------------------|-------------|------|
| 55-57 | Spark plug wire grommet clamp, use with FAC-12111-A bracket. . . . . | FAA-12361-A | 3.95 |
|-------|----------------------------------------------------------------------|-------------|------|

- |       |                                                                     |             |      |
|-------|---------------------------------------------------------------------|-------------|------|
| 55-57 | Spark plug wire grommet, square type, 4 holes (2 required). . . . . | FAA-12297-A | 2.95 |
|-------|---------------------------------------------------------------------|-------------|------|

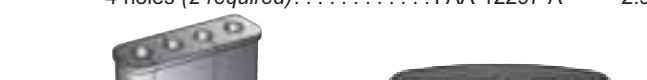

- |       |                                                                       |             |      |
|-------|-----------------------------------------------------------------------|-------------|------|
| 55-57 | Spark plug wire grommet, in-line type, 4 holes (2 required) . . . . . | FAA-12297-C | 2.95 |
|-------|-----------------------------------------------------------------------|-------------|------|

- |       |                                                               |             |      |
|-------|---------------------------------------------------------------|-------------|------|
| 56-57 | Spark plug wire separator, comb-shaped (2 required) . . . . . | B6A-12297-A | 1.95 |
|-------|---------------------------------------------------------------|-------------|------|

- |       |                                                               |             |      |
|-------|---------------------------------------------------------------|-------------|------|
| 56-57 | Spark plug wire separator, comb-shaped (2 required) . . . . . | B6A-12297-A | 1.95 |
|-------|---------------------------------------------------------------|-------------|------|

## Spark Plug Wire Grommet Kit

**BUY a KIT & SAVE**

- |       |                                                                                                                                           |              |           |
|-------|-------------------------------------------------------------------------------------------------------------------------------------------|--------------|-----------|
| 55-57 | Each kit contains (2) FAA-12297-A square grommets, (2) FAA-12297-C in-line grommets & (2) B6A-12297-A spark plug wire separators. . . . . | FAA-12297-KT | 11.95 kit |
|-------|-------------------------------------------------------------------------------------------------------------------------------------------|--------------|-----------|





When you consider how many different systems must operate within a distributor, you can easily see why they are so critical to the performance of any internal combustion engine. First, there is the primary ignition circuit, then the secondary ignition circuit, the timing system, the vacuum system, the lubrication system...whew! So many things can go wrong; it is amazing that they work as well as they do! Here at MAC's, we know how important it is for your T-Bird to start, run & perform like a new car. Because we believe that the distributor is such a vital ingredient in the way your engine runs, we offer these top-quality distributor parts. Call today.

## Distributor Tune-Up Kits

Save money—buy the kit! All you need to tune up your distributor in one package at one low, low price. Our tune-up kits include points, condenser & rotor. Individual kit components are available in the next listings.

### \$UPER \$AVER

Save **BIG BUCKS** when you buy the kit!



- 55-56 Contains points, condenser & rotor . . . . .B2Q-12000-B 11.95 kit
- 1957 Contains points, condenser & rotor . . . . .B8Q-12000-A 11.95 kit



## Distributor Point Sets



- 55-56 Distributor point set . . . . .FAB-12171-B 4.95 set
- 1957 Distributor point set, **except** supercharged . . . . .A12151CPT 3.40 set

## Distributor Cam Lube



- 55-57 Made with silicone for superior lubrication & long life, generous 7/8 oz. tube, a must for every toolbox! . . . . .A12210L 7.95

## Distributor Condensers



- 55-56 Distributor condenser . . . . .7RA-12300-C 4.95
- 1957 Distributor condenser, **except** supercharged . . . . .B7A-12300-C 4.95



## Distributor Rotors



- 55-56 Distributor rotor . . . . .59A-12200 2.95
- 1957 Distributor rotor . . . . .B7A-12200-A 5.95

## Distributor Primary Lead & Ground Wires



- 55-56  Distributor primary lead wire . . . . .CODF-12216-A 12.95
- 55-56  Distributor ground wire . . . . .7RA-12264 3.95

## Distributor Caps



- 55-56 Distributor cap . . . . .FAB-12106 5.45
- 1957 Distributor cap . . . . .B7A-12106-A 8.95

## Distributor Cap Hold-Down Clamps & Rivet



- 55-56 Distributor cap hold-down clamps. 7RA-12144-PR 9.95 pair
- 55-57 Rivet, used to attach cap hold down clamps . . . . .A12145 0.50 pair

## Distributor Vacuum Advance



- 1957 Distributor vacuum advance, **except** supercharged . . . . .B7A-12370-A 55.95

## Distributor to Carburetor Vacuum Lines

- 1955 Distributor to carburetor vacuum line . . . . .B5S-12371-A 15.95
- 1956 Distributor to carburetor vacuum line, 2-piece set . . . . .B6S-12371-ST 15.95 set
- 1957 Distributor to carburetor vacuum line . . . . .B7S-12371-A 15.95

## Distributor Gear & Pin



- 55-57  Distributor gear, 14 teeth . . . . .FAE-12390-A 14.95
- 55-57 Distributor gear pin, **Genuine Ford** . . . . .61489-S 0.95

## Distributor Shaft Seal

- 55-57 **Motorcraft**. . . . .FAA-12476-A 6.95



Take a good look at your lights, lenses & overall brightness of your lighting system. Old faded lenses & corroded reflectors cause your lights to look dim. The brightness of your light bulbs is generally effected by ground wires & sockets while their brilliance is enhanced by the plastic lenses. Bright & beautiful lights are an asset to any nice car & MAC's has the parts to restore the beauty of your light systems. You will love the restored appearance that new bezels, lenses & gaskets will add to your car. Find all of the parts you need in MAC's comprehensive listings for your Ford. Hint: Always take pictures of your car with the lights on. It will enhance the beauty of your ride.

## Sealed Beam Headlights (2 required)



1955	6 volt	B13007SB	12.00
56-57	12 volt	B-13007-12	6.95
56-57	12 volt, "FoMoCo" script	CODF-13007-AS	17.95

## Headlight Retaining Rings (2 required)



55-57	Plain steel	01A-13018	11.00
55-57	Stainless	01A-13018-SS	18.75

## Headlight Door Lower Retainer Clip (2 required)

55-57	Retainer clip	B5S-13008-C	6.95
-------	---------------	-------------	------

## Headlight Bucket Spring (2 required)

55-57		11A-13031	3.95
-------	--	-----------	------

## Headlight Bucket to Fender Gasket (2 required)



55-57		11A-13044	3.30
-------	--	-----------	------

## Headlight Bulb Pigtail (2 required)



55-57	For 3-prong sealed beams	01A-13076-U	2.25
-------	--------------------------	-------------	------

See our full wiring selection on pages 60 & 61

## Parking Light Housings (2 required)

See our headlight, parking light & tail light wiring on pages 60-61



1955	Includes correct wire pigtail	B5S-13206-A	41.95
55-56	Housing only	B5S-13206-HSG	29.95



1956	Includes correct wire pigtail	B6S-13206-A	42.95
1957	Includes correct wire pigtail	B7S-13206-A	59.95

## Parking Light Lenses

55-56	Right or left (2 required)	FAG-13208-B	8.95
1957	Right	B7S-13208-A	11.95
1957	Left	B7S-13209-A	11.95



1957	Right, with "Ford" script	B7S-13208-AR	13.95
1957	Left, with "Ford" script	B7S-13209-AR	13.95

## Parking Light Hardware (as required)

55-56	Parking light lens screw	354746-S	0.95
1957	Parking light lens screw	354899-S	1.25

## Parking Light Lens Retainer & Gaskets



55-56	Retainer (2 required)	B4AZ-13210-A	11.95
55-56	Lens gasket	FAG-13211-A	4.95 pair
1957	Lens gasket	B7S-13211-PR	3.95 pair

## Parking Light Body to Fender Pads (2 required)



55-56		B5S-13217-B	4.95
1957		B7S-13217-A	2.95

## Map Light Parts



55-57	Socket & wire lead (shown)	B5S-13796	7.95
55-57	Switch & wires, includes attaching rivets	B8S-13764-A	9.95



55-57	Lens	B5S-13761-AR	4.95
55-57	Housing	B5S-13765-A	23.95



**Tail Light Lenses** (2 required)

Plastic lenses are another easy fix. Old lenses & gaskets that are unbroken will sometimes be left in place by a restorer, until that person parks next to a similar car with a beautiful brand new reproduction lenses. The old faded & dull lenses look very weak by comparison & dirty, cracked gasket edges look shabby sticking out from behind the lens. One comparative look from the new restorer & at the next show you can be sure that BOTH cars will have new lenses. Put new light bulbs, lenses, gaskets & connectors on your T-Bird & brighten your "outlook!"



- 1955 Tail light lens . . . . . B5A-13450-A 12.95
- 1955 Tail light lens, with "FoMoCo" script . . . . . B5A-13450-AR 16.95



- 1956 Tail light lens . . . . . B6A-13450-A 20.95
- 1956 Tail light lens, with "FoMoCo" script . . . . . B6A-13450-AR 24.95

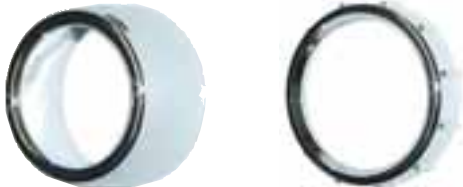

- 1957 Tail light lens, with back-up light lens in center . . . . . B7A-13450-B 39.95
- 1957 Tail light lens, with back-up light lens in center, with "FoMoCo" logo . . . . . B7A-13450-BR 49.95
- 1957 Tail light lens, without back-up light lens in center . . . . . B7A-13450-C 12.95

**Tail Light Lens Bezels** (2 required)

- 1955 Chrome . . . . . B5A-13489-A 13.95
- 1956 Chrome . . . . . B6A-13489-A 17.95



- 1957 Bright finish, without back-up lights . . . . . B7A-13489-A 18.95
- 1957 Bright finish, with back-up lights . . . . . B7A-13489-B 18.95

**Tail Light Housing to Body Pads**

- 55-56 Tail light housing to body pads . . . . . B6A-13420-PR 9.95 pair
- 1957 Tail light housing to body pad (2 required) . . . . . B7A-13420-B 3.95

**Tail Light Buckets** (2 required)

- 1955 With correct pigtail & socket . . . . . B5AZ-13434-A 44.95
- 1956 With correct pigtail & socket . . . . . B6AZ-13434-A 44.95

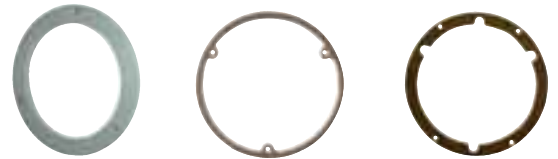
**Tail Light Lens to Housing Gaskets** (2 required)

- 1955 . . . . . B5A-13461-A 3.95
- 1956 . . . . . B6A-13461-A 3.95
- 1957 . . . . . B7A-13461-B 3.95

**Tail Light Hardware** (as required)

- 1955 Tail light lens screw . . . . . 353624-S 0.95
- 1956 Tail light lens screw . . . . . 354798-S 1.95
- 1957 Tail light lens screw . . . . . 354899-S 1.25
- 1957 8-piece screw set . . . . . 1HK43H 7.95 set

**Tail Light Sockets** (2 required)

- 55-56 Wire pigtail & socket assembly, exact reproduction . . . . . B5S-13410-A 20.95
- 1957 Wire pigtail & socket assembly, exact reproduction . . . . . B7S-13410-A 19.95
- 1955 Tail light socket, 2 wires with sockets, 7" long . . . . . FDH-13410-A 11.95

- 1956 Tail light socket, 2 wires with sockets, 7" long . . . . . FDR-13410-A 12.95

- 1957 Tail light socket, 2 wires with sockets, 7" long . . . . . FDR-13410-B 18.95



## Back-up Light Lens to Housing Gaskets

1955	.....	B5A-15510-APR	4.95 pair
1956	.....	B6A-15510-PR	4.95 pair

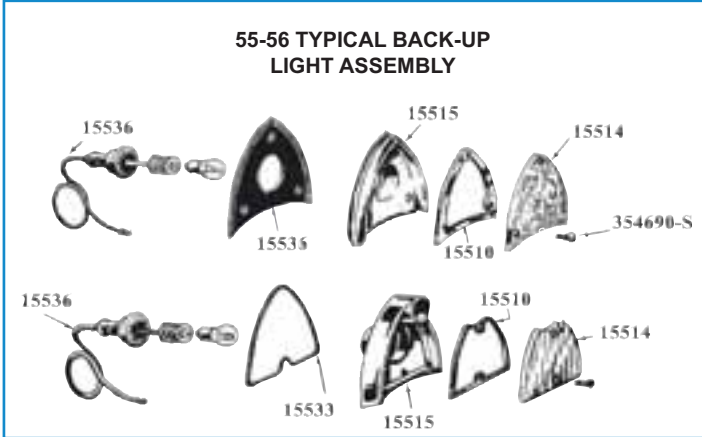

## Back-up Light Housing Reflector (2 required)

1956	.....	B6A-13437-A	5.95
------	-------	-------------	------

## Back-up Light Lenses

1955	Back-up light lens, with "FoMoCo" logo (2 required) .....	B5A-15514-AR	12.95		
1955	Back-up light lens (2 required) .....	B5A-15514-A	10.95		
1956	Back-up light lens, with "FoMoCo" logo (2 required) .....	B6A-15514-BR	12.95		
1956	Back-up light lens (2 required) .....	B6A-15514-B	10.95		
1955	Back-up light lens screw, 3 per lens (6 required) .....	354690-S	1.95		
1956	Back-up light lens screw, 2 per lens (4 required) .....	354973-S	1.95		

## Back-up Light Housings (2 required)

1955	Chrome .....	B5A-15515-A	29.95
1956	Chrome .....	B6A-15515-A	41.95

## Back-up Light Housing to Body Gaskets & Blank-off Plate Pad (2 required)

1955	Back-up light housing to body gasket. ....	B5A-15533-A	2.95
1956	Back-up light housing to body gasket. ....	B6A-15533-A	2.95
1955	Blank-off plate pad, for vehicles without back-up lights .....	B5A-15533-B	4.95

## Back-up Light Wires (as required)

55-56	Back-up light pigtail .....	FDR-15536-ALS	4.95
1955	Back-up light wire, 2 PVC wires (black & red) .....	B5S-15506-A	14.95
1955	Back-up light wire, 1 PVC wire (black & red), 66" long .....	FDR-15525-A	6.95
1955	Back-up light socket wire, PVC wire, 13" long, without socket .....	FEA-15536-ALS	3.95
56-57	Back-up light wiring .....	B6S-15525-B	44.95

## Front License Plate Bracket

55-56	Front license plate bracket .....	B5S-17736-A	18.95
-------	-----------------------------------	-------------	-------

## Light Gasket Kits

*If you want to replace all of the gaskets on your car's exterior (which is probably a good idea since they are more than 50 years old), then we have just what you need! We put together these kits to save you money & make it easier for you to get all the gaskets you need. Each kit contains the gaskets for the head lights, parking lights, tail lights, back-up lights & the license plate light.*

**BUY a KIT & SAVE**

1955	Gasket kit for cars with back-up lights .....	B5S-13000-WKT	37.95 kit
1955	Gasket kit for cars without back-up lights .....	B5S-13000-WOKT	36.95 kit

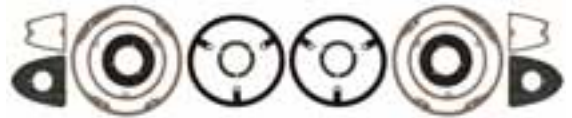

1956	Gasket kit for all '56 T-birds (shown) .....	B6S-13000-KT	33.95 kit
1957	Gasket kit for all '57 T-birds .....	B7S-13000-KT	24.95 kit



**Rear License Plate Holder**

1955 Rear license plate holder, 3-piece set. . . . . BA-13596-ST 10.95 set

**Rear License Plate Light Lens Retainer**



55-56 Rear license plate light lens retainer. B5S-13423-A 15.95

**Rear License Plate Light Gasket**

1957 Gasket, housing to light socket. . . . B7S-13668-A 1.95

**Rear License Plate Light Bodies**



55-56 Rear license plate light body. . . . . B6S-13560-A 34.95  
 1957 Rear license plate light body. . . . . B7S-13560-A 25.95

**Rear License Plate Light Lenses**



55-56 Rear license plate light lens . . . . . B6S-13564-A 16.95  
 1957 Rear license plate light lens . . . . . B7S-13564-A 15.95

**Rear License Plate Light Lens Retainer**



1957 Rear license plate light lens retainer . . . . . B7S-13566-A 18.95

**Rear License Plate Light Lens Gaskets**



55-56 Rear license plate light lens gasket . B6S-13568-A 1.95  
 1957 Rear license plate light lens gasket . B7S-13568-A 1.95

**Rear License Plate Light Assemblies**



1955 6 volt . . . . . B5S-13550-A 70.95  
 1956 12 volt (shown) . . . . . B6S-13550-A 70.95



1957 12 volt . . . . . B7S-13550-A 82.95

**Light Bulb Pliers**



ALL  Assists in removing broken, brittle or corroded bulbs from sockets. . . TOOL-BULB 22.50

**License Plate Light Wires & Socket**

1955 License plate light wire, 2 black PVC wires, 54" long, without bracket . . . . . B5S-13560-ALB 7.95  
 1956 License plate light wire, 2 black PVC wires, 26" long, without bracket . . . . . B6S-13560-ALB 11.95



1957 License plate light socket, 10" long. . . . . B7S-13412-AR 14.95

**Find the bulb you need quickly & easily!**

LOCATION	1955	1956	1957
Parking & tail light	B13465D3 . . . . . 1.50	13466-1034 . . . . . 1.95	13466-1034 . . . . . 1.95
License plate light	B13466 . . . . . 0.75	V13465D . . . . . 0.80	V13465D . . . . . 0.80
Back-up light	B13465 . . . . . 0.95	13466-1073 . . . . . 1.95	13466-0093 . . . . . 1.95
Map light	13466-0081 . . . . . 1.95	V13465D . . . . . 0.80	V13465D . . . . . 0.80
Turn signal indicator	13466-0051 . . . . . 1.95	13466-0057 . . . . . 1.95	13466-0057 . . . . . 1.95
Radio dial	13466-0044 . . . . . 0.95	13466-0057 . . . . . 1.95	13466-1891 . . . . . 1.95
Hi-beam indicator	V13465I . . . . . 0.90	13466-0057 . . . . . 1.95	13466-0057 . . . . . 1.95
Transmission gear indicator	13466-0051 . . . . . 1.95	13466-1445 . . . . . 1.95	13466-1445 . . . . . 1.95
Instrument panel	V13465I . . . . . 0.90	13466-0057 . . . . . 1.95	13466-0057 . . . . . 1.95







Take a good look at the wiring on your collector car. Does it consist of makeshift plugs, mismatched jumper wires & suspicious



looking wads of electrical tape? Many years can take a heavy toll on connectors, leaving them so corroded that little or no current will pass through. MAC's wiring harnesses are made to meet the highest standards, so you can unplug the "bad" & plug in the "good."

We use the correct color wires with correct color tracers so you can refer to an original wiring diagram for proper routing. The plugs are just like the originals, simply plug them in!

## Wiring Harnesses

1955	Dash wiring harness, PVC wire, using generator & oil lights . . . . .	B5S-14401-A	421.95
1956	Dash wiring harness, molded ends, using generator & oil lights . . . . .	B6S-14401-A	487.95
1957	Dash wiring harness, molded ends, using generator & oil lights . . . . .	B7S-14401-A	572.95
1955	Body wiring with turn signal wire, PVC wire, 10 terminals . . . . .	B5S-14405-B	71.95
55-57	Oil sending unit to cowl wire, PVC wire . . . . .	FEF-14322-A	5.95
1956	Body wiring with turn signal wire, PVC wire, 10 terminals . . . . .	FEF-14405-G	107.95
1956	Body wiring with turn signal & back-up light wiring . . . . .	FEF-14405-H	125.95
1956	License light wire, 16" long . . . . .	B6S-14415-A	8.95
1957	Body wiring harness, PVC wire, 16 terminals, with automatic transmission . . . . .	B7S-14405-C	108.95
1957	Body wiring harness, PVC wire, 16 terminals, with manual transmission . . . . .	B7S-14405-D	116.95

## Headlight Wires

1955	Braided, full length ground, 27" long, with grommet (2 required) . . . . .	B5S-13076-A	29.95
1956	Molded PVC wire, full length ground, 27" long, with grommet (2 required) . . . . .	B5S-13076-AM	29.95
1957	Right, flat PVC wire with full length ground & grommet, 71" long . . . . .	B7S-13076-A	29.95
1957	Left, flat PVC wire with full length ground & grommet, 23" long . . . . .	B7S-13077-A	24.95

## Parking/Tail Light & Turn Signal Wires

1955	Parking light socket wire with turn signal, PVC wire, right . . . . .	B5S-13206-AR	32.95
1955	Parking light socket wire with turn signal, PVC wire, left . . . . .	B5S-13206-AL	32.95
1955	Tail light socket, 2 wires with sockets, 7" long (2 required) . . . . .	FDR-13410-A	11.95
1956	Parking light & turn signal socket, PVC wire, right . . . . .	B6S-13206-AR	29.95
1956	Parking light & turn signal socket, PVC wire, left . . . . .	B6S-13206-AL	29.95



1956	Tail light socket, 2 wires with sockets, 7" long (2 required) . . . . .	FDR-13410-A	12.95
1957	Parking light socket & wire, 27" long (2 required) . . . . .	B7S-13234-A	24.95
1957	Tail light socket, 2 wires with sockets, 7" long (2 required) . . . . .	FDR-13410-B	18.95
1957	Parking light & horn crossover wire, 47" long, using push-on terminal . . . . .	B7S-14445-B	27.95

## License Plate Light Wires & Socket

1955	License plate light wire, 2 black PVC wires, 54" long, without bracket . . . . .	B5S-13560-ALB	7.95
1956	License plate light wire, 2 black PVC wires, 26" long, without bracket . . . . .	B6S-13560-ALB	11.95



1957	License plate light socket, 10" long . . . . .	B7S-13412-AR	14.95
------	------------------------------------------------	--------------	-------

## Dome Light Wires

1955	Dome light wire, PVC wire, 4" long . . . . .	FAC-13796-AP	2.95
1955	Map light socket, PVC wire, 4" long . . . . .	B5S-13754-ALB	9.95
56-57	Map light socket, PVC wire, 4" long, molded ends . . . . .	B6S-13754-ALB	10.95

## Generator to Regulator Wire

1957	PVC wire, 29-1/2" long . . . . .	B7S-14305-A	19.95
------	----------------------------------	-------------	-------

## Ignition Coil to Distributor Wires

1955	PVC wire, 15" long . . . . .	FDL-14302-A	3.95
56-57	14" long . . . . .	FDV-14302-A	4.95

## Horn Wires

1955	With shell, spring, insulator & rivet, 71" long . . . . .	B5S-14308	17.95
56-57	With shell, spring, insulator & rivet, 71" long . . . . .	B6S-14308-A	19.95

## Heater Wires

1955	Heater switch to heater motor, braided wire, 44" long . . . . .	FEA-14309-A	10.95
1955	Heater motor wire, braided wire, 12" long, early 1955 only . . . . .	FEA-18527-W	9.95
56-57	Heater switch to heater motor, PVC wire, 44" long, molded ends . . . . .	FEA-14309-AM	16.95
56-57	Ignition switch to heater motor, PVC wire, 44" long, with fuse . . . . .	B6S-14309-B	19.95
56-57	Heater blower motor wire, 12" long . . . . .	FEF-18527-W	11.95

## Oil Pressure Sending Unit to Cowl Wire

56-57	28" long . . . . .	FEF-14322-A	5.95
-------	--------------------	-------------	------

## Overdrive Wires

1955	59" long . . . . .	B5S-14382-A	29.95
56-57	47" long . . . . .	B6S-14382-A	34.95

## Headlight Crossovers

1955	PVC wire, 19 terminals, with generator & turn signal wires . . . . .	B5S-14445-D	45.95
1956	PVC wire, 19 terminals, with generator & turn signal wires . . . . .	B6S-14445-MU	54.95

## Parking Light & Turn Signal Crossover

1957	PVC wire, 47" long . . . . .	B7S-14445-A	23.95
------	------------------------------	-------------	-------

## Wiring Junction Blocks

55-56	Single stack, mounts on right apron . . . . .	B5S-14448-A	16.95
55-56	Installs under dash . . . . .	B5S-14448-C	18.95
55-57	Double stack, mounts on left apron . . . . .	B5S-14448-B	18.95



**Neutral Safety Switch Wire**

56-57 PVC wire . . . . . FEF-14476-A 27.95

**Shift Light Wires**

1956 **NEW** Without socket, PCV wire,  
7-1/2" long . . . . . B5S-13715-ALS 2.95  
56-57 **NEW** Without socket, molded end,  
7-1/2" long . . . . . B6S-13715-ALS 3.95

**Turn Signal Switch Wires**

1955 6 wires, 34" long . . . . . B5S-14486-A 21.95  
56-57 6 wires, 34" long . . . . . B6S-14486-A 29.95

**Wiring Harness Strap**



55-57 Holds wiring to engine compartment,  
molded black plastic (as required) . . . 376914-S 0.95

**Ignition Coil to Ignition Resistor Wires**

56-57 PVC wire, **except** with dual  
carburetors, 3-1/2" long . . . . . FDR-14495-A 4.95  
1957 Only with dual carburetors,  
8-1/2" long . . . . . FEJ-14495-B 4.95

**Instrument Ground Jumper Wire**

55-56 PVC wire, 5 terminals . . . . . B5S-14590-A 10.95

**Back-up Light Wires (as required)**

1955 Back-up light wire, 2 PVC wires  
(black & red) . . . . . B5S-15506-A 14.95  
1955 Back-up light wire, 1 PVC wire  
(black & red), 66" long . . . . . FDR-15525-A 6.95  
1955 Back-up light socket wire, PVC  
wire, 13" long, without socket . FEA-15536-ALS 3.95



1956 **NEW** Without socket, PCV wire,  
13" long . . . . . FDR-15536-ALS 4.95  
56-57 Back-up light wiring . . . . . B6S-15525-B 44.95

**Power Seat Wires**

56-57 Seat circuit breaker to starter  
solenoid wire, 45" long . . . . . FEF-14682-A 7.95  
1957 Seat regulator relay wire, 94" long,  
with Dial-A-Matic power seat . . . B7S-14643-B 159.95  
1957 Seat regulator control wire, 69" long,  
with Dial-A-Matic power seat . . . B7S-14774-A 47.95

**Power Window Wires**

1955 Power window wiring, right,  
12 terminals . . . . . B5S-14630-A 59.95  
1955 Power window & power seat wires,  
PVC wire, left, 23 terminals. . . . B5S-14631-A 89.95

**Heater Blower Motor Wires**

1955 Braided wire, early 1955 . . . . . FEA-18527-W 9.95  
56-57 PVC wire . . . . . FEF-18527-W 11.95

**Electric Clock Feed Wire**

56-57 With fuse holder, 8" long . . . . . B6A-15026-A 19.95

**Door Wiring Shields**



55-57 Right . . . . . B5S-4020768-A 36.95  
55-57 Left . . . . . B5S-4020769-A 36.95

**Grommets**

55-57 Grommet, inner apron wiring hole,  
rubber coated (4 required) . . . . . 352873-L 3.95  
1957 Grommet, for parking light wire  
(2 required) . . . . . 352873-S 3.95

**Bulk Wire**

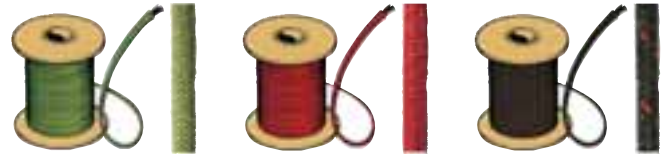

CLOTHWIRE/GRN CLOTHWIRE/RED CLOTHWIRE/BR

ALL #16 cloth covered primary wire,  
black, sold by the foot,  
please specify length. . . . . CLOTHWIRE/BLK 0.50 foot  
ALL #16 cloth covered primary wire,  
green, sold by the foot,  
please specify length. . . . . CLOTHWIRE/GRN 0.50 foot  
ALL #16 cloth covered primary wire,  
blue, sold by the foot,  
please specify length. . . . . CLOTHWIRE/BLU 0.50 foot  
ALL #16 cloth covered primary wire,  
red, sold by the foot,  
please specify length. . . . . CLOTHWIRE/RED 0.50 foot  
ALL #16 cloth covered primary wire,  
yellow, sold by the foot,  
please specify length. . . . . CLOTHWIRE/YLW 0.50 foot  
ALL #16 cloth covered primary wire, black  
with a green tracer, sold by the foot,  
please specify length. . . . . CLOTHWIRE/BG 0.50 foot  
ALL #16 cloth covered primary wire, black  
with a red tracer, sold by the foot,  
please specify length. . . . . CLOTHWIRE/BR 0.50 foot  
ALL #16 cloth covered primary wire, black  
with a yellow tracer, sold by the foot,  
please specify length. . . . . CLOTHWIRE/BY 0.50 foot

**Glass Tube Fuses**

*We have all the glass tube fuses you'll ever need for your classic Thunderbird. Sold in sets of 5, you can replace your bad fuse today & keep spares "just in case."*

1955 SFE-20, set of 5 pieces,  
for the heater. . . . . AOAZ-14526-B 2.95 set  
1955 SFE-14, set of 5 pieces,  
for the radio . . . . . AOAZ-14526-A 2.95 set  
1955 AGA-3, set of 5 pieces,  
for the clock. . . . . A6AZ-14526-A 3.95 set  
1955 SFE-9, set of 5 pieces,  
for the turn signals . . . . . A6AZ-14526-B 2.95 set  
55-57 SFE-9, set of 5 pieces,  
for the map light . . . . . A6AZ-14526-B 2.95 set  
1955 AGC-30, set of 5 pieces,  
for the overdrive . . . . . A9AZ-14526-A 2.95 set  
56-57 SFE-14, set of 5 pieces,  
for the heater. . . . . AOAZ-14526-A 2.95 set  
56-57 SFE-9, set of 5 pieces,  
for the clock. . . . . A6AZ-14526-B 2.95 set  
56-57 AGC-15, set of 5 pieces,  
for the overdrive . . . . . A2AZ-14526-A 2.95 set

**180° Bullet Splice**

55-57 180° bullet splice with black rubber  
sleeve (as required) . . . . . A14487 0.45

*Need more help? We carry reprints of several original Ford motor company electrical assembly manuals on pages 105. These books show full schematics, harness diagrams & are loaded with technical illustrations. These are reprints of the books that Ford used when engineering T-Birds. Check out our **Books & Manuals** section!*



## Dash Pads

You look directly at your dash pad every time you slide behind the wheel. If it is cracked, faded or just looks tired & old, we can supply you with a brand new replacement in a variety of factory colors. Made to the highest standards, each one features the correct grain vinyl & has all the factory ribs molded right in, as well as an indent for the speaker grille. A new dash pad might be the last piece you install in your interior restoration & it might be the most important. Do yourself a favor & call today!

1957	<b>NEW</b>	<b>OS</b>	Black . . . . .	B7S-4004290-BLK	415.95
1957	<b>NEW</b>	<b>OS</b>	Blue . . . . .	B7S-4004290-BLU	415.95
1957	<b>NEW</b>	<b>OS</b>	Bronze . . . . .	B7S-4004290-BRZ	415.95
1957	<b>NEW</b>	<b>OS</b>	Green . . . . .	B7S-4004290-GRN	415.95
1957	<b>NEW</b>	<b>OS</b>	Red . . . . .	B7S-4004290-RED	415.95
1957	<b>NEW</b>	<b>OS</b>	White . . . . .	B7S-4004290-WHT	415.95

## Dash Pad Retainer Strip Set



1957	4 pieces, metal strips that screw to the front of the dash pad metal shell, prevents front of pad from shrinking away from under lower mouldings . . . . .	B7S-4004291-ST	11.95 set
------	------------------------------------------------------------------------------------------------------------------------------------------------------------	----------------	-----------

## Dash Pad Finish Panels

55-57	Finish panel, at end of dash, right . . . . .	B5S-4004358-A	14.95
55-57	Finish panel, at end of dash, left . . . . .	B5S-4004359-A	14.95

## Dash Trim

### Kits

Need a few pieces but don't have the extra cash, buy a kit & SAVE some of that cash!



55-56	<b>Save</b> Engine turned aluminum, 4 pieces . . . . .	B5S-04338-KT	297.95 kit
1957	<b>Save</b> Engine turned aluminum, 4 pieces, does not include instrument cluster piece . . . . .	B7S-04338-AKT	297.95 kit
1957	<b>Save</b> Engine turned aluminum, 5 pieces, includes instrument gauge cluster piece . . . . .	B7S-04338-BKT	414.95 kit

### Individual Pieces



55-56	Left end . . . . .	B5S-4004393-B	51.95
55-56	Center . . . . .	B5S-4004338-B	104.95



55-57	Right end . . . . .	B5S-4004392-A	51.95
55-57	Glove box door cover (shown) . . . . .	B5S-4006036-A	113.95



1957	Left end . . . . .	B7S-4004393-A	51.95
1957	Center . . . . .	B7S-4004338-A	103.95



1957	Instrument gauge cluster . . . . .	B7S-4004338-IC	129.95
------	------------------------------------	----------------	--------

## Dash Nameplate & Emblem



55-56	Dash nameplate, "Thunderbird," very early production 1955s had this mounted on the ashtray door, 1956 models with optional dash pad did not use this nameplate . . . . .	B5S-4004460-A	22.95
-------	--------------------------------------------------------------------------------------------------------------------------------------------------------------------------	---------------	-------



55-56	Dash emblem, Y-block "V-8" engine logo, attaches to glovebox aluminum trim . . . . .	B6A-7004407-A	13.95
-------	--------------------------------------------------------------------------------------	---------------	-------

## Dash Gauge Lenses



55-56	Tachometer face plate (lens), with recessed numbers . . . . .	B5S-17360-FP	18.95
1957	Speedometer face plate (lens), with recessed numbers . . . . .	B7S-10A936-A	3.95
1957	Small gauge lens, for fuel, tachometer & water temperature (3 required) . . . . .	B7S-10A936-B	3.95

## Dash Gauge Lens Seals



1957	<b>Save</b> Kit, 5 pieces, includes trim ring seals for the speedometer & the 4 smaller gauges. . . . .	B6A-17248-KT	5.95 kit
1957	Speedometer trim ring seal . . . . .	B6A-17248-C	1.95
1957	Small gauge trim ring seal (4 required) . . . . .	B7S-17248-A	1.95

## Dash Gauge Trim Rings

1957	<b>Save</b> Set, 5 pieces, includes trim rings for the speedometer, the clock & the 3 gauges . . . . .	B6A-10877-ST	67.95 set
1957	Speedometer trim ring . . . . .	B6A-10840-B	21.95
1957	Clock trim ring . . . . .	B7S-15010-A	14.95



1957	Small gauge trim ring (3 required) . . . . .	B6A-10876-A	11.95
------	----------------------------------------------	-------------	-------

## Clock Faces

55-56	Clock face, with recessed numbers . . . . .	B5S-18374	18.95
1957	Clock face, with "F" & "S" markings . . . . .	B7S-18374	10.95
1957	Clock trim ring . . . . .	B7S-15010-A	14.95





### Dash Bezels & Retainers

- 55-56 Inner, turn signal indicator, polished stainless steel (2 required) . . . . . B5S-17314-B 33.95
- 55-56 Retainers, for turn signal indicator lenses . . . . . B5S-17314-R 8.95 pair



- 55-57 Outer, chrome, used on wipers, left air, ignition & lights (as required) . . . . . FAA-10853-A 11.95



- 55-57 Inner, "LIGHTS" . . . . . B9S-10852-B 14.95
- 55-57 Inner, "RIGHT AIR," only used on cars with no heater . . . . . B5S-10852-A 18.95
- 55-57 Inner, "LEFT AIR" . . . . . B5S-10852-B 14.95
- 55-57 Inner, "LIGHTER" . . . . . FAB-15059-A 17.95



- 55-57 Inner, "BLOWER," "OFF," "1," "2" . . . . . B5S-10852-C 14.95
- 55-57 Inner, "WIPERS" . . . . . FAA-10852-A 17.95
- 55-57 Inner, "AC," "OFF," "ON," "START" . . . . . B5S-11580-A 17.95



- 55-57 Retaining nut for ignition switch bezel. . . . . B6A-11585-A 14.95

### Temperature Gauges



- 1955 In dash gauge, for 6 volt system (not shown) . . . . . B5A-10883-A 91.95
- 1955 In dash gauge, includes sending unit, for 12 volt system . . . . . B5A-10883-12V 119.95 set
- 1956 **NEW** In dash gauge, for 12 volt system . . . . . B6S-10883-A 91.95
- 1956 **NEW** In dash gauge, includes sending unit, for 12 volt system . . . . . B6S-10883-ST 134.95 set

### Speedometer Parts



- 1955 Driven gear, 20 teeth, nylon, only with manual transmission & 3.91 rear end gear ratio. . . . . B5A-17322-AR 14.95
- 55-56 Face plate (lens), with recessed numbers . . . . . B5S-17265-A 39.95



- 55-56 Dome, green tinted plastic . . . . . B5A-17319-C 31.95
- 55-56 **NEW** Driven gear, 19 teeth, manual transmission with 3.73 rear end ratio & Ford-O-Matic with 3.31 rear end ratio . . . . . B5A-17322-CR 14.95
- 55-56 **NEW** Driven gear, 21 teeth . . . . . B5A-17322-BR 14.95

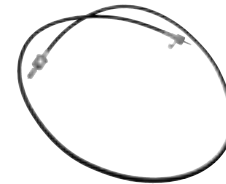

- 55-56 Cable housing & core, 45" long (shown) . . . . . B5S-17260-A 19.95
- 55-56 Cable connector & spring clip . . . . . B5A-17306-B 14.95
- 55-56 Angle drive . . . . . B5S-17279-B 175.95



- 1956 **NEW** Driven gear, 20 teeth (shown) . . . . . B5A-17322-AR 14.95
- 55-57 Driven gear seal, "O" ring . . . . . 1A-17298 2.95
- 55-57 Retainer, driven gear to cable . . . . . B7AZ-17292-A 2.95



- 1957 Driven gear, 19 teeth, steel . . . . . B5A-17322-CS 42.95
- 1957 Driven gear, 19 teeth, nylon (shown) . . . . . COAA-17271-K 22.95
- 1957 **NEW** Driven gear, 22 teeth, "F" code super-charged 312 engine with manual transmission & 3.73 rear end ratio (shown) . . . . . B5A-17322-DR 14.95
- 1957 Speedometer bezel, chrome . . . . . B6A-10840-B 21.95
- 1957 Cable housing & core, 60" long, **except** 312 with 3-speed manual or with overdrive (shown) . . . . . C5DZ-17260-A 25.95

### Speedometer Cable Lubricant



- ALL Graphite in oil formulated especially for long-life, all-temperature lubrication of speedometer cable . . . . . A17260L 2.50



**Tachometer Parts**

1955 Cable & housing . . . . . B5S-17365-A 38.95



55-56 Face plate (lens), with recessed numbers. . . . . B5S-17360-FP 18.95  
 55-56 Needle. . . . . B5S-17360-N 18.95  
 55-56 "O" ring, for cable & housing (not shown) . . . . . B3Q-17383-A 0.95



55-57 Driven gear (shown) . . . . . FAA-17374-A 36.95  
 55-57 Clip, secures tach cable to firewall . . . 17365-CLIP 1.95  
 56-57 Cable & housing . . . . . B7S-17365-A 38.95

**Ignition Switch & Parts**



55-57 Switch, does not include the lock cylinder, which is listed below . . . B5A-11572-A 24.95



55-57 **NEW** Lock cylinder & 2 keys (shown) . . . . . B9A-11582-A 11.95  
 55-57 Spring, for switch. . . . . 1A-11581-A 2.95



55-57 Switch inner bezel, lettered "AC," "OFF," "ON," "START" . . . . . B5S-11580-A 17.95



55-57 Switch outer bezel, chrome. . . . . FAA-10853-A 11.95



55-57 Switch bezel retainer nut. . . . . B6A-11585-A 14.95

**Neutral Safety Switch**

55-57 Includes bracket & wiring . . . . . B6SZ-7A247-A 82.95

**Headlight Switch & Parts**



56-57 Switch, has fuse carrier, does not include the knob & shaft (shown) . . . . . B7A-11654-A 51.95  
 55-56 Knob & shaft . . . . . B5A-11661-A 19.95  
 1957 Knob & shaft . . . . . B7S-11661-A 19.95  
 55-56 Nut, headlight switch retainer . . . . . B5A-11650-A 14.95  
 1957 Nut, headlight switch retainer . . . . . B7S-11650-A 14.95

**Dimmer Switches & Cover**



55-56 With screw type terminals. . . . . A8AZ-13A024-A 13.95  
 1957 With spade terminals. . . . . B7AZ-13A024-A 17.95  
 55-57 Rubber cover, a copy of an original accessory (not shown) . . C5ZZ-13533-A 4.95

**Turn Signal Switch & Parts**

55-57 Switch . . . . . B6SZ-13341-A 93.95



55-57 **NEW** Switch plate retainer spring, used with 3/16" diameter stud. . . . 1M-13343-A 3.95  
 55-57 **NEW** Switch plate retainer spring, used with 5/16" diameter stud. . . 1M-13343-AM 3.95



55-57 **NEW** Knob, press-on type, black plastic. . . . . B4A-13305-A 6.95



1955 Lever (shown) . . . . . B5S-13305-A 15.95  
 1955 Canceling plate . . . . . B5S-13304-A 44.95



1955 Flasher, 6 volt . . . . . A13350 4.90  
 55-57 Canceling cam . . . . . FAB-13318-A 15.95



55-57 Switch plate pawl . . . . . 1M-13309-A 6.95



55-57 Switch plate pawl spring. . . . . 1M-13316-A 1.95  
 56-57 Lever (not shown) . . . . . B6S-13305-A 15.95  
 56-57 Canceling plate . . . . . B6S-13304-A 47.95

**Brake Light Switch**

55-57 Brake light switch, at master cylinder . . . . .C1AZ-13480-A 7.95

**Courtesy Light Switch**

55-57 Courtesy light switch, on door jamb . . . 8M-13713 6.95

**Heater Control Knobs**

1955 Heater – defroster & temperature control knob, wedge type (2 required) . . . . . B5S-18519-A 12.95  
 55-57 Blower motor knob (not shown) . . . FDA-18513-A 19.95  
 56-57 Heater – defroster & temperature control knob, round type (2 required) . . . . . B6A-18519-A 12.95

**Heater Blower Motor Switch & Parts**

55-57 Heater blower motor switch . . . . . B5S-18578-A 30.95  
 55-57 Retaining nut, for the heater blower motor switch (not shown) . . 1A-13753-A 14.95  
 55-57 Switch inner bezel, "BLOWER," "OFF," "1," "2" . . . . . B5S-10852-C 14.95

**Cigar Lighter Parts**

1955 Cigar lighter assembly, with socket, 6 volt . . . . . B5S-15052-A 55.95  
 1955 Cigar lighter element, 6 volt . . . . . B5S-15054-A 15.95



55-57 Cigar lighter knob & shaft, without bezel . . . . . B5S-15052-K 22.95  
 56-57 **NEW** Cigar lighter socket & element, 12 volt . . . . . B6C-15055-A 16.95



56-57 Cigar lighter assembly, with socket, 12 volt . . . . . B7S-15052-A 46.95  
 56-57 Cigar lighter element, Ford service replacement, 12 volt . . . D3AZ-15054-A 10.95

**Wiper Control (at dash)**

55-57 Windshield wiper control, at dash . . . B7S-17470-A 59.95

**Wiper Control Retaining Nuts**

55-56 Retaining nut, for the wiper control at the dash . . . . . 1A-13753-A 14.95  
 1957 Retaining nut, for the wiper control at the dash . . . . . B7S-17512 12.95

**Glove Box Parts**

55-56 Emblem, Y-block "V-8," with threaded stud & nut . . . . . B6A-7004407-A 13.95  
 55-57 Liner, made of heavy waterproofed board, includes correct clips . . . B5S-4006010-B 15.95  
 55-57 Striker, plated . . . . . B5A-7006064-B 11.95  
 55-57 Door latch guide plate (not shown) . . . . . B5S-4006151-A 5.95



55-57 Door arm, right . . . . . B5S-4006117-AP 6.95  
 55-57 Door arm, left . . . . . B5S-4006118-AP 6.95



55-57 **NEW** Check arm stop bumper, rubber (2 required) . . . . . B7A-7006122 2.95



55-57 Door grommets & bumpers kit . . B5S-4006606-KT 4.95 kit



55-57 Door finish panel, engine turned aluminum finish (shown) . . . . . B5S-4006036-A 113.95  
 55-57 Door lock push button bezel . . . . B5S-4006190-A 7.95  
 55-57 Door hinge, replacement type . . . . B5S-4006050 5.95





## Horns



- 56-57 12 volt, low pitch replacement. . . . . B8A-13833-A 23.95
- 56-57 12 volt, high pitch replacement. . . . . B8A-13832-A 23.95

**NOW AVAILABLE – Original looking “snail” style horns!**



- 56-57 Horns, 12 volt, original “snail” style, “HI” & “LO” horns with an all-metal housing & ABS plastic domes. . . B6S-13832-PR 62.95 pair

## Horn Parts



- 1955 Horn ring medallion bezel, power steering (shown). . . . . B5S-13A806-P 21.95
- 1955 Horn ring medallion. . . . . B5S-3636-A 24.95
- 56-57 Horn ring pad . . . . . B5A-3672-A 1.95
- 56-57 Horn ring insulator (3 required). . . . . B5A-3673-A 1.95
- 56-57 Horn ring attaching plate. . . . . B6S-13A800 15.95
- 56-57 Horn ring contact plate . . . . . B6S-13A801 15.95
- 56-57 Horn ring screw & grommet kit . . . . . B6S-13A804 11.95 kit
- 56-57 Horn ring rubber insulator. . . . . B6S-13A806 6.95



- 56-57 Horn ring spring. . . . . B4AZ-13A807-A 3.95



- 1956 Horn ring medallion (shown). . . . . B6A-3627 33.95
- 1957 Horn ring medallion (shown). . . . . B7S-3636-A 27.95
- 1956 Horn ring medallion background plate, silver . . . . . B6S-13A810 17.95
- 1957 Horn ring medallion background plate, black . . . . . B7S-13A810 17.95

## Horn Relays

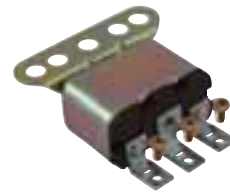

- 1955 Horn relay, 6 volt. . . . . 7RA-13853-A 11.95

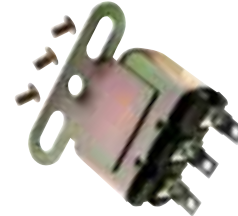

- 1956 Horn relay, 12 volt (not shown). . . . . B6A-13853-A 22.95



- 1957 Horn relay, 12 volt. . . . . B8C-13853-A 9.95

## Horn Ring Kits

*Attention 1955 owners –Get your original horn ring rechromed & call us—we have all the parts to make your horn ring look brand new all in one convenient money saving kit. Included are the horn ring attaching plate, contact plate, spacer plate, chrome sleeve & gasket, lower retaining plate, screw & grommet kit, clear plastic lens, medallion bezel for either manual or power steering, rubber insulator, the grommet for the medallion & the medallion itself.*

- 1955 Horn ring kit, manual steering, see above for contents . . . . . B5S-13A805-MKT 194.95 kit
- 1955 Horn ring kit, power steering, see above for contents . . . . . B5S-13A805-PKT 194.95 kit

## Horn Wires

- 1955 With shell, spring, insulator & rivet, 71" long. . . . . B5S-14308 17.95
- 56-57 With shell, spring, insulator & rivet, 71" long. . . . . B6S-14308-A 19.95



# HOOD

## Hood Scoop Grille



55-57 Chrome . . . . . B5S-16607-A 72.95

## Hood Latch Parts (2 required)



55-57 Hood latch trigger spring . . . . . B5S-16921-A 3.95  
 55-57 Hood latch hinge pin, made in 2 pieces so you can replace B5S-16921-A trigger spring separately . . . . . B5S-16700-B 11.95  
 55-57 Hood latch spring, allows hood to pop up . . . . . B5S-16925-A 3.95

## Hood to Cowl Seals

1955 Hood to cowl seal, 7 drive nails (351629-S) needed . . . . . B5S-16740-A 4.95  
 56-57 Hood to cowl seal, 7 drive nails (351629-S) needed . . . . . B6S-16740-A 5.95  
 55-57 Drive nails for hood to cowl seal, as original (7 required) . . . . . 351629-S 0.95

## Hood Bumper Sets



1956 4 pieces . . . . . B6S-16758-ST 5.95 set  
 1957 4 pieces . . . . . B7S-16758-ST 8.95 set

## Hood Hinge Spring (2 required)



55-57 Hood hinge spring . . . . . B5S-16812-A 11.95

## Hood Hinge Bracket



55-57 **NEW** Right (shown) . . . . . B5S-16798 28.95  
 55-57 **NEW** Left . . . . . B5S-16799 28.95

## Hood Scoop Block-off Plate Parts

55-57 Kit includes: block-off plate, decal, 4 clips & 4 nuts . . . . . B5S-16813-KT 16.95 kit



55-57 Hood scoop block-off plate (shown) . . . . . B5S-16813-A 6.95  
 55-57 Clip (4 required) . . . . . B5S-16873-A 1.95

## Hood Release Cables, Brackets & Clamp



55-57 Cable, with handle (shown) . . . . . BAK-16916-A 31.95  
 55-57 Cable bracket, at firewall (shown) . . . . . B5S-16907-A 14.95  
 55-57 Cable clamp (as required) . . . . . 16H-16877-B 5.95  
 55-56 Bracket, under dash, chrome . . . . . B5S-16930-CHR 11.95  
 1957 Bracket, under dash, black . . . . . B7S-16930-BLK 8.95

## Grilles



55-56 **OS** Grille . . . . . B5S-8200-AR 345.95  
 1957 **OS** Grille, shown with bumper . . . . . B7S-8200-AR 347.95

## Grille Mouldings

55-56 Right . . . . . B5S-8242-B 39.95  
 55-56 Left . . . . . B5S-8243-B 39.95  
 1957 Right . . . . . B7S-8242-AR 51.95  
 1957 Left . . . . . B7S-8243-AR 51.95  
 55-56 Upper . . . . . B5S-8419-AR 57.95  
 1957 Upper . . . . . B7S-8419-AR 59.95  
 55-56 Lower . . . . . B5S-8156-AR 83.95  
 1957 Lower, chrome . . . . . B7S-17202-B 143.95

# GRILLES

## Upper Grille Panel Nameplates & Ornaments



1955 Nameplate, plastic insert . . . . . BM-7325662-B 28.95  
 1955 Ornament, chrome, two 375890-S barrel clips are needed to mount . . . . . B6A-7925666-C 36.95



1955 Ornament, crossed flags . . . . . B5S-4042550-A 13.95



56-57 Nameplate, plastic insert . . . . . B6S-8218-A 19.95



56-57 Ornament, chrome . . . . . B6S-8259-B 35.95



ALL Barrel clips (as required) . . . . . 375890-S 0.60

Visit our Website:

[macsautoparts.com](http://macsautoparts.com)

Office/Technical:  
**(716) 210-1340**

Prices are each, unless otherwise noted.  
Prices subject to change without notice.



## Cowl Vent Knobs (2 required)



- 56-57 Without screwdriver impression, all '56s & early '57s . . . . . B6S-4002145-A 4.95
- 1957 With screwdriver impression, most '57s (not shown) . . . . . B7S-4002145 4.95

## Cowl Side Vent Door Spring (2 required)



- 56-57 . . . . . B6S-4002154-B 4.95

## Cowl Side Vent Control Arms

- 56-57 Cowl side vent control arm, right . . . B7S-4002128 6.95
- 56-57 Cowl side vent control arm, left . . . B7S-4002129 6.95

## Seals (2 required)



- 56-57 Vent door seal, molded as original . . . . . B6S-4002158-C 10.95
- 56-57 Vent door seal, die-cut sponge . . . . . B6S-4002158-DCS 2.95
- 56-57 Cowl screen seal . . . . . B6S-4002162-B 2.95
- 56-57 Inner cowl vent seal . . . . . B6S-4002166-B 2.95

## Cowl Side Vent Hinge Assembly (2 required)



- 55-57 . . . . . B6S-4002176-B 23.95

## Cowl Side Vent Grille (2 required)

- 56-57 Chrome . . . . . B6S-4002216-A 30.95

## Cowl Side Vent Screens

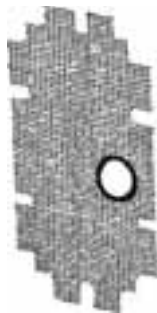

- 56-57 Right . . . . . B6S-4002280-A 6.95
- 56-57 Left . . . . . B6S-4002281-A 7.95

## Original-Type Firewall Cover & Clips



- 55-57 **NEW** OS Firewall cover, fire resistant board with correct stitching on sewn-on rubber flaps . . . . . B5S-4001670-A 44.95
- 55-57 Clip set, 1-3/8" reach as original, 12 pieces (shown) . . . . . B5S-4001670-ST 37.95 set

## ABS Firewall Cover & Clips

- 55-57 **NEW** OS Made of tough ABS material to fit over the firewall, ready to install, no holes to drill, no cutting required, requires 9 cover clips (listed below) . . . . . B5S-4001670-B 218.95
- 55-57 Firewall cover clip, green color like original (9 required) . . . . . 357036-S 3.95
- 55-57 Metal, replacement type, 7/8" reach with a 1-1/8" overall length (9 required) . . . . . 48-7001670-A 2.75



- 55-57 **NEW** Metal, replacement type, 1/2" reach with a 3/4" overall length (9 required) . . . . . 48-7001670-B 2.75



- 55-57 **NEW** Plastic, replacement type, 7/8" reach with a 1-1/8" overall length (9 required) . . . . . 390018-S 0.95

## Firewall Grommet Set



- 55-57 6 pieces . . . . . B5S-4001605-ST 16.95 set

## Firewall Grommets

- 55-57 Tachometer cable grommet . . . . . 354962-S 2.95
- 55-57 Right vent cable grommet . . . . . 353626-S 3.95
- 55-57 Hood cable grommet . . . . . 354125-S 3.95
- 55-57 Wire loom grommet . . . . . 354387-S 4.95



- 55-57 Retainer, for wire loom grommet listed above (354387-S) (above left) . . . . . 8A-14608 9.95
- 55-57 Wiper vacuum hose grommet . . . . . 355428-S 1.95
- 55-57 Washer hose grommet . . . . . 373195-S 3.95
- 55-57 Speedometer cable grommet, with manual transmission (above right) . 1A-7001694 4.95
- 55-57 Speedometer cable grommet, with Ford-O-Matic transmission . . . . . B7S-4001694 1.95





**Windwing Assemblies**



**NOTE:** Windwing assemblies include glass, the chrome frame & the upper pivot, but do NOT include lower hinge.

- 56-57 Right, clear glass, "FoMoCo" logo . . . . . B6S-4003228-C 81.95
- 56-57 Right, green tinted glass, "FoMoCo" logo (shown). . . . . B6S-4003228-T 82.95
- 56-57 Left, clear glass, "FoMoCo" logo . . . . . B6S-4003229-C 81.95
- 56-57 Left, green tinted glass, "FoMoCo" logo . . . . . B6S-4003229-T 82.95

**Windwing Glass Retainer Strip (2 required)**



- 56-57 . . . . . 4003229-A 1.95

**Windwing Glass (2 required)**

- 56-57 Clear, right or left. . . . . B6S-03229-C 16.95
- 56-57 Tinted, right or left. . . . . B6S-03229-T 17.95

**Windwing Frame (2 required)**

- 56-57 Fits right or left . . . . . B6S-4003227 42.95

**Windwing Hinges & Bushings**

- 56-57 Hinge, upper, right, with rivets. . . . . B6S-4003230-A 19.95
- 56-57 Hinge, upper, left, with rivets. . . . . B6S-4003231-A 19.95



- 56-57 Hinge, lower, right, without hardware (above left) . . . . . B6S-4003232-A 18.95
- 56-57 Hinge, lower, left, without hardware. . . . . B6S-4003233-A 20.95
- 56-57 Hinge bushing (2 required) (above right) . . . . . B6S-4003234-A 2.95
- 56-57 Hinge bushing & screw set (2 required) . . . . . B6S-4003234-ST 12.95 set

**PORTHOLE**

**Porthole Installation Kits**

Porthole kits include inside & outside rings, rubber seals, clear or tinted glass with "FoMoCo" logo, spacers, 4 bow headliner in white or bone, template & instructions. Hardware is not included. To purchase the hardware kit, see the last item in this listing. Individual kit components are listed after these kits.

- 56-57 Clear, with "FoMoCo" logo, includes bone headliner . . . . . B6S-4030000-BC 239.95 kit
- 56-57 Tinted, with "FoMoCo" logo, includes bone headliner . . . . . B6S-4030000-BT 239.95 kit
- 56-57 Clear, with "FoMoCo" logo, includes white headliner . . . . . B6S-4030000-WC 239.95 kit
- 56-57 Tinted, with "FoMoCo" logo, includes white headliner . . . . . B6S-4030000-WT 239.95 kit
- 56-57 Porthole rings to hard top hardware kit, 8 pieces, 1 kit does both sides. . . . . B6S-4030000-KT 2.95 kit

**Porthole Glass (2 required)**

No additional handling charges apply to Porthole glass.

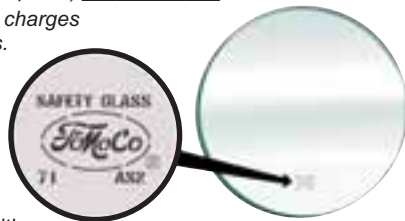

- 56-57 Clear, right or left, with "FoMoCo" bug . . . . . B6S-4029710-C 17.95
- 56-57 Tinted, right or left, with "FoMoCo" bug . . . . . B6S-4029710-T 19.95

**Porthole Glass Seal (2 required)**

- 56-57 Rubber (2 in illustration) . . . . . B6S-4029904-A 3.95

**Inside Porthole Rings**



- 56-57 Chrome (1 in illustration). . . . . B6S-4029004-PR 45.95 pair

**Outside Porthole Rings**



- 56-57 Chrome (3 in illustration). . . . . B6S-4030534-PR 70.95 pair

**1956-1957 HARDTOP PORTHOLE & PARTS**

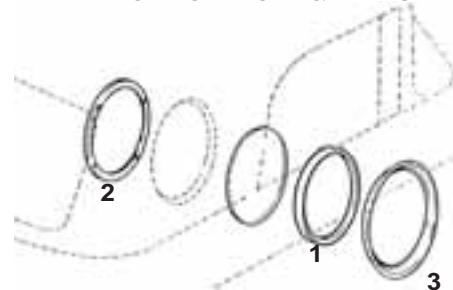

**DOOR GLASS**

**Door Glass (2 required)**

Each door glass carries a flat shipping fee of \$19.00 & an additional handling charge of \$5.00.

- 55-57 Clear, right or left, with "FoMoCo" logo . . . . . B5S-4021410-C 35.95
- 55-57 Tinted, right or left, with "FoMoCo" logo . . . . . B5S-4021410-T 38.95



The windshield wiper system on any car works pretty hard during its lifetime, unless you live in an arid climate. Even then, sunlight & heat are hard on various components. Over many years wiper motors drag the wipers & related transmission components back & forth across the big windshield in every kind of weather. Snow loads are especially hard on wiper motors. Wiper blades are subject to temperature extremes & excessive wear. Wiper arms lose their spring tension, which allows the blade to skip over the glass, even with fresh rubber refills. Then there is the washer system, with the washer pump, hoses, connectors, brackets, reservoir bag & other components. Keep your vehicle's windshield wiper system in top working order. Call today for all the parts you need.

## Windshield Wiper Motor Conversion Kit

Convert your old vacuum wipers to electric (12 volt systems only!) This conversion kit has been designed & tested for proper operation, with no modifications to be made. The whole assembly bolts on where your old wiper motor mounted. Your old cable-type switch is replaced with an electric two-speed switch, included in the kit. Complete detailed instructions & schematic diagrams included!



**If your '55 has been converted to 12 volts, this kit will work perfectly!**



56-57 From vacuum to electric motor, 12 volt systems only . . . . . B5S-17508-KT 269.95 kit

## Windshield Wiper Retainer Plate & Spring

55-56 Windshield wiper retainer plate & spring . . . . . BA-17450-A 6.95

## Windshield Wiper Control Knob

55-57 Windshield wiper control knob . . . . . EAG-17513-A 16.95

## Windshield Wiper Control

55-57 Windshield wiper control, at dash . . . . . B7S-17470-A 59.95

## Windshield Wiper Control Nuts

55-56 Nut, for the wiper control at the dash . 1A-13753-A 14.95  
1957 Nut, for the wiper control at the dash . .B7S-17512 12.95

## Windshield Wiper Pivot Bezels



55-57 **NEW** Chrome . . . . . B5A-17514-PR 24.95 pair

## Windshield Wiper Arms

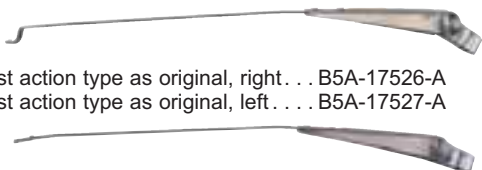

1955 Wrist action type as original, right . . . B5A-17526-A 34.95  
1955 Wrist action type as original, left . . . . B5A-17527-A 34.95

56-57 Bayonet type as original, right . . . . . B5A-17526-C 34.95  
56-57 Bayonet type as original, left . . . . . B5A-17527-C 34.95

## Windshield Wiper Arm & Blade Kits

Get "correct" wiper arms & blades for your classic & save money too! We have put together a couple of convenient kits that include concours versions of wiper arms, plus concours correct blade assemblies. Call us & order a set for your car today.



1955 **Save** Wiper arm & blade kit, includes right & left wrist action arms plus 2 wrist action blade assemblies . . . . . B5S-17526-KT 131.95 kit



56-57 **Save** Wiper arm & blade kit, includes right & left bayonet type arms plus 2 bayonet type blade assemblies . . . . . B6S-17526-KT 134.95 kit

## Windshield Wiper Blades & Refills (2 required)



1955 Wrist action type as original, 12" long . . . . . B5S-17528-A 34.95



56-57 Bayonet type as original, 12" long . . . B6S-17528-A 36.95  
55-57 Wiper blade refill, as original, 12" long . . . . . B2A-17528 7.95



55-57 Anco replacement type, works with wrist action type & has adaptor for bayonet type arms . . . . . 17528-12 11.95

## Windshield Wiper Arm to Pivot Shaft Washer



55-57 Leather (2 required) . . . . . B5A-17541-A 0.95

## Windshield Wiper Arm to Motor Grommet



55-56 (2 required) . . . . . 51A-17562 1.95

## Windshield Washer Hose

55-57 Enough hose to replace entire system . . . . . B5S-17543-ST 8.95 set



**Windshield Washer Hose Tees**



- 55-57 On top of washer bag, "F" shaped . . . . . BF-17615-A 14.95
- 55-57 At firewall, "T" shaped . . . . . B5S-17587-A 1.95

**Windshield Washer Hose Filter**

- 55-57 Fits into the end of the hose that is inside the washer bag. . . . . B5S-17543-FILT 5.95

**Windshield Washer Bags & Parts**

*Made of brand new shiny vinyl, you won't believe the difference a new washer bag will make under your hood! Our "See Clear" version is red with white lettering & all are just like the originals. Give us a call & order yours today.*



- 1955 Bag, "See Clear," exact reproduction, cap (BM-17632-A) not included . . B5S-17618-A 32.95
- 1956 Bag, "See Clear," exact reproduction, cap (BM-17632-A) not included . . B6S-17618-A 32.95
- 1957 Bag, "See Clear," exact reproduction, cap (BM-17632-A) not included . . B7S-17618-A 32.95



- 55-57 Bag rest . . . . . B5S-17652-A 6.95
- 55-57 Bag bracket . . . . . B5S-17651-A 13.95
- 55-57 Bag cap, screw type (not shown) . . . BM-17632-A 4.95

**Windshield Washer Pedals, Pad & Clip**



- 55-57 Pedal, includes retainer, does not include pedal pad—see below . . . B5S-17537-A 12.95



- 55-57 Pedal pad . . . . . B5S-17537-P 4.95



- 55-57 Retainer "hairpin" clip only, for washer pedal . . . . . B5S-17537-R 1.95

**Windshield Washer Pump, Spring & Bulb**

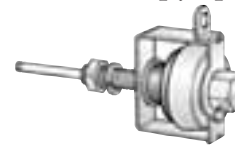

- 55-57 Windshield washer pump, correct for 55 & 56, replacement for 57 . . . . . B6S-17664-A 90.95
- 55-56 Spring, stainless steel, inside washer pump . . . . . B6S-17664-S 1.95
- 55-56 Rubber bulb, for pump . . . . . B5A-17664-BULB 7.95

**Windshield Washer Fluid Jets & Seals**



- 55-57 Jets (nozzles), like original . . . . . B5S-17666-PR 28.95 pair
- 55-57 Jet to body seals . . . . . B5S-17666-SPR 1.95 pair

**Windshield Wiper Pivot Shaft Nut**



- 55-57 (2 required) . . . . . 356094-SR 5.95



**Take a look at our massive book section.**

*It's filled with books about the history of T-Birds, reference books loaded with photographs, owner's manuals, identification books, wiring manuals & the all-important Shop Manual—a must have for any T-Bird owner. Read & learn from the pros on how to repair, repaint & fully restore your Thunderbird.*

**Call & order your favorites today!**





## Inside Rear-View Mirrors

You think your mirror looks ok, but do you know how good our mirrors look? Examine the polished back & the perfect reflection of the glass & you'll be convinced that our mirror would look great in your interior.



- 1955 2-3/4" arm, bracket not included . . . B5S-17700-B 28.95
- 56-57 3-1/16" arm, bracket not included . . . B6S-17700-A 28.95

For those of you who want a day/night mirror, we have the solution—our 1960 T-Bird mirror fills the bill. It's all chrome & has a twist type day-night switch. Bracket not included.

- 55-57 Chrome, twist type day/night mirror . COSZ-17700 81.95

### Brackets



- 55-57 Without logo . . . . . B5S-17702-A 13.95
- 55-57 With "FoMoCo" logo . . . . . B5S-17702-AR 15.95

## Outside Rear-View Mirrors

Factory originals never included base gaskets, but our two concurs mirrors do! If you opt for our more economic models, to protect your paint, MAC's offer 2 gaskets for this mirror: paper (B4A-17724-A) or rubber (B5A-17724-R), both listed below.



- 1955 One-hole type . . . . . B5AZ-17696-A 34.95
- 56-57 Two-hole type . . . . . B5AZ-17696-B 34.95

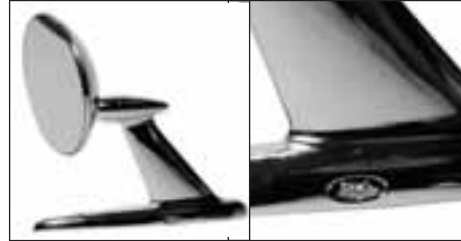

- 1955 One-hole type, concurs quality with "FoMoCo" cast into base, chrome, base gasket included . . . . . B5A-18402 75.95



- 56-57 Two-hole type, concurs quality with "FoMoCo" cast into base, chrome, base gasket included . . . . . B5A-18402-A 75.95

### Outside Rear-View Mirror Base Gaskets

To protect your paint we offer a paper or a rubber base gasket for our B5AZ-17696-A or B mirrors.



- 55-57 Paper, made for 2-hole mount, but fits 1-hole mount if you cut hole for mounting . . . . . B4A-17724-A 1.95
- 55-57 Molded rubber, made for 2-hole mount, but fits 1-hole mount if you cut hole for mounting . . . . . B5A-17724-R 5.95



- ALL Simichrome polish, for brass, chrome, silver or virtually any metal. 1.76 oz. tube, simply the best! . . . . . POLISH 6.75



## Front Bumper Brackets

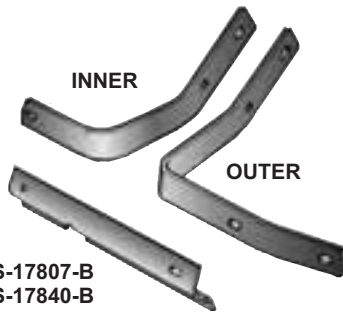

<b>Inner</b>			
55-56	Right	B5S-17766-B	41.95
55-56	Left	B5S-17767-B	41.95
1957	Right	B7S-17766-A	41.95
1957	Left	B7S-17767-A	41.95
<b>Outer</b>			
55-56	Right	B5S-17754-A	41.95
55-56	Left	B5S-17755-A	41.95
1957	Right	B7S-17754-A	41.95
1957	Left	B7S-17755-A	41.95

## Front Bumper End Braces & Spacer

1957	Right	B7S-17204-A	45.95
1957	Left	B7S-17205-A	45.95
1957	Spacer, U-shaped, connects end brace to stone deflector end (2 required)		B7S-17200 15.95

## Rear Bumper Brackets

<b>Inner</b>			
1955	Right	B5S-17787-A	45.95
1955	Left	B5S-17788-A	45.95
<b>Outer</b>			
1955	Right	B5S-17795-A	45.95
1955	Left	B5S-17796-A	45.95

## Jacking Plates

55-56	Front bumper, right	B5S-17807-B	37.95
55-56	Front bumper, left	B5S-17840-B	37.95



1955	Rear bumper, right	B5S-17918-A	39.95
1955	Rear bumper, left	B5S-17919-A	39.95



1956	Rear bumper, right or left (2 required)	B6S-17918-A	33.95
------	-----------------------------------------	-------------	-------

## Bumper Guard Sleeve & Spacer Kits

1955	2 spacers & 2 sleeves, fits front or rear, 1 kit does 2 guards, bumper guards not included (2 required)		B5S-17759-KT 8.95 kit
1956	2 spacers & 2 sleeves, front only, 1 kit does 2 guards, bumper guards not included		B5S-17759-KT 8.95 kit

## Rear Bumper Bracket to Rear Frame Crossmember Braces

1956	Right	B6S-17675-A	22.95
1956	Left	B6S-17676-A	22.95

## Rear Stone Deflector to Bumper Seals



1956	Rear (2 required)	B6S-17808-A	3.95
------	-------------------	-------------	------



1957	Rear, one piece extends full length of bumper seal	B7S-17808-A	9.95
------	----------------------------------------------------	-------------	------

## Rear Stone Deflector Staple Kits

1956	1 kit does both sides	B6S-17808-AKT	1.95 kit
1957	1 kit does both sides	B7S-17808-AKT	1.95 kit

## Bumper Bolts

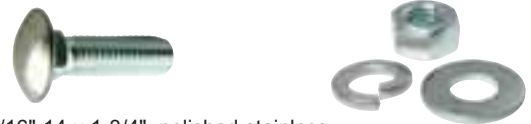

55-57	7/16"-14 x 1-3/4", polished stainless steel cap (as required)	B9A-17758-A	2.95
-------	---------------------------------------------------------------	-------------	------

55-57	<b>NEW</b> Nut & 2 washers for above listed bumper bolt (as required)	B9A-17758-NW	0.95 set
-------	-----------------------------------------------------------------------	--------------	----------

Now you can have all the correct style & length bolts, plus the flat washers, lock washers & nuts all in one convenient package.



**BUY a KIT & SAVE**

1955	<b>Save</b> Kit, 48 pieces	B5S-17758-KT	15.95 kit
1956	<b>Save</b> Kit, 48 pieces	B6S-17758-KT	15.95 kit
1957	<b>Save</b> Kit, 24 pieces	B7S-17758-KT	7.95 kit

## Exhaust Deflectors

1956	Exhaust deflector, right	B6S-5202-C	36.95
1956	Exhaust deflector, left	B6S-5203-C	36.95
1957	Steel (2 required)	B7S-5202-A	31.95
1957	Stainless steel (2 required)	B7S-5202-SS	49.95

ALL Chrome paint, great for refinishing the metal reflector of tail lights, backup lights, parking lights for increased visibility, also works great on dingy, dull bumpers, 12 oz. spray can . . . . .RSP24 \* 5.95

\* **HAZARDOUS MATERIAL** can only be shipped by ground/surface within the U.S. because of government regulations.





## Heater Blower Motor & Parts

- 56-57 Motor, 12 volt replacement type . . . . .B6S-18527 156.95
- 55-57 Mounting plate, for blower motor . B5S-18568-MP 15.95
- 55-57 Heat shield, attaches to blower mounting plate. . . . . B5S-18568-HS 16.95

## Heater Blower Motor to Housing Grommet



- 55-57 . . . . . B6S-18528-A 4.95

## Heater Blower Motor Fan

- 55-57 Heater blower motor fan ("squirrel cage") . . . . . FAA-18504-A 16.95

## Heater Blower Motor Switch



- 55-57 Heater blower motor switch . . . . . B5S-18578-A 30.95

## Heater Plenum Chamber



- 55-57 Heater plenum chamber . . . . . B5S-18471-B 57.95

## Heater Case Gaskets

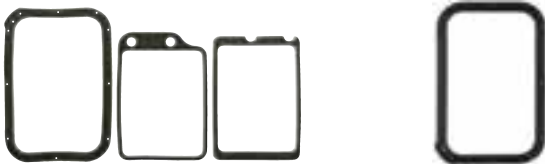

- 55-57 Heater case gasket set, heater to firewall, 3 pieces (includes the following 3 items) (shown) . . . . . B5S-18570-ST 8.95 set
- 55-57 Heater core to case gasket. . . . . B2A-18658-A 2.95
- 55-57 Heater duct to case gasket. . . . . B2A-18688-A 2.95
- 55-57 **NEW** Heater to dash gasket (shown) . . . . . FAA-18570-A 2.95

## Air Vent to Heater Blower Housing Connecting Duct Strap



- 55-57 Air vent to heater blower housing connecting duct strap . . . . . 18584-STRAP 1.95

## Heater Core



- 55-57 Heater core . . . . . FAA-18476-A 99.95

## Heater Seals



- 55-57 Heater seal, glues to back of heater door (shown) . . . . . B5S-18480-A 1.95
- 55-57 Heater seal, felt, defroster flapper valve, inside heater box. . . . . B5S-18480-B 2.95

## Heater Door Knob



- 55-57 Heater door knob, ivory plastic . . . . . FAB-19203-A 7.95

## Heater Control Levers



- 55-57 Heater control lever, lower . . . . . B6A-18574-B 18.95



- 55-57 Heater control lever, upper . . . . . B5S-18575 18.95

## Heater Control Bezel, Face Plate & Backing Plate



- 55-57 Heater control bezel, chrome . . . . . B5S-18550 34.95



- 55-57 Heater control face plate . . . . . B5S-18619 12.95

- 55-57 Backing plate, for heater face plate listed above . . . . . B5S-18620 5.95

## Heater Control Cables

- 55-57 Heater control cable, 18" long. . . . . B5S-18518-A 10.95
- 55-57 Heat & defrost control cable, 15-1/2" long. . . . . FEA-18548-A 14.95



- 55-57 Heater control cable retaining clip. . . 18548-BRKT 2.95
- 55-57 Right air control cable . . . . . B5S-18548 15.95





**Heater Ducts & Clamps**



- 55-57 Round, 6" long x 3.92" diameter . . . . . B5A-18584-A 14.95
- 55-57 Clamp, for round heater duct . . . . . B5A-8725-A 3.95
- 55-57 Square . . . . . B6A-18489-A 14.95



- 55-57 Heater to blower air duct clamp, square . . . . . FAA-8725-A 5.95

**Heater Inlet Duct Deflector**

- 55-57 Deflector, fits inside heater inlet duct . . B5S-18457 6.95

**Defroster Hose**



- 55-57 2-1/2" diameter, 36" long, cut to fit . . B5A-18556-C 19.95

**Defroster Nozzle Seal**



- 55-57 Defroster nozzle seals . . . . . B5S-18490-PR 6.95 pair

**Heater Hose & Clamp Set**

- 55-57 Heater hose, 5/8" diameter, black as original, sold in feet . . . . . 18472-58 0.95 foot
- 55-57 Heater hose clamp, clamps heater hose to inner fender panel . . . . . B5S-18481-A 5.95
- 55-57 Heater & bypass hose clamp set . . B5S-18473-ST 6.95 set

**Elbow**



- 55-57 Elbow, heater hose to water pump, 3/8" thread, 20° bend . . . . . 8A-18599-R 11.95

**Ventilator System Parts**



- 55-57 Vent register . . . . . B6S-4001820-A 18.95
- 55-57 Vent cable bracket, with clips . . . . . B5S-4001822-A 8.95
- 55-57 Vent air damper seal, at left fender apron . . . . . B5S-4001872-A 1.95

- 55-57 Vent air valve gasket . . . . . BA-7001880-A 1.95

- 55-57 Air duct gasket set, 6 pieces, includes 4 vent air valve gaskets, 1 vent air damper seal & 1 air vent duct seal. . . . . BA-7001880-ST 6.95 set

- 55-57 Air duct scoop, right, steel, with screen . . . . . B5S-4001914-R 94.95

- 55-57 Air duct scoop, left, steel, with screen . . . . . B5S-4001915-L 94.95



- 55-57 Air duct seal (shown) . . . . . B5S-4001973-A 1.95
- 55-57 Vent cable bracket clip . . . . . 359474-S 3.95
- 55-57 Screen, for air duct scoop, right . . . . . B5S-4001905 3.95
- 55-57 Screen, for air duct scoop, left . . . . . B5S-4001906 3.95

**Vent Control Assemblies**

- 55-57 Right, without heater . . . . . B5S-4001890-R 47.95
- 55-57 Left . . . . . B5S-4001891-L 47.95
- 55-57 Right . . . . . B5S-4001890-A 23.95

**Air Valve Damper Door Assembly & Pivot Rod**



- 56-57 Air valve damper door assembly, 3-1/2" x 5-3/4" . . . . . 8A-7001862-A 20.95
- 56-57 Pivot rod for above door . . . . . 8A-7001863 12.95

**For Heater Wires & Blower Motor Wires, see page 60 & 61**





## Front Fender Splash Shields & Weatherstripping

55-57	Front fender splash shield, right lower front . . . . .	B5S-16102-R	14.95
55-57	Front fender splash shield, left lower front, see illustration A . . . . .	.B5S-16103-L	14.95
55-57	Weatherstripping, for lower front splash shields listed above, see illustration B . . . . .	B5S-16254-PR	3.95 pair
55-57	Front fender apron splash shield, over upper A-arms (2 required), see illustration C . . . . .	BM-16240-PR	17.95 pair
55-57	Retainer, for front fender apron splash shield, listed above (2 required), see illustration D . . . . .	.BM-16050	23.95
55-57	Staple set, for attaching BM-16240-PR seal, listed above . . . . .	B5S-16240-ST	0.95 set
55-57	Brace, fender to fender apron, see illustration E . . . . .	.B5S-16222-A	7.95
56-57	Front fender splash shield, left lower rear, see illustration F . . . . .	.B6S-16103-A	45.95
56-57	Front fender splash shield, right lower rear . . . . .	.B6S-16102-A	45.95
56-57	Weatherstripping, includes staples to install, for lower rear splash shields listed above, see illustration G . . . . .	B5S-16110-PR	6.95 pair
56-57	Front fender splash shield, rear upper, right or left (2 required), see illustration H . . . . .	.B6SZ-16102-A	4.95
56-57	Retainer strap, holds B6SZ-16102-A upper splash shield to lower splash shield (2 required), see illustration J . . . . .	B6SZ-16112	1.95

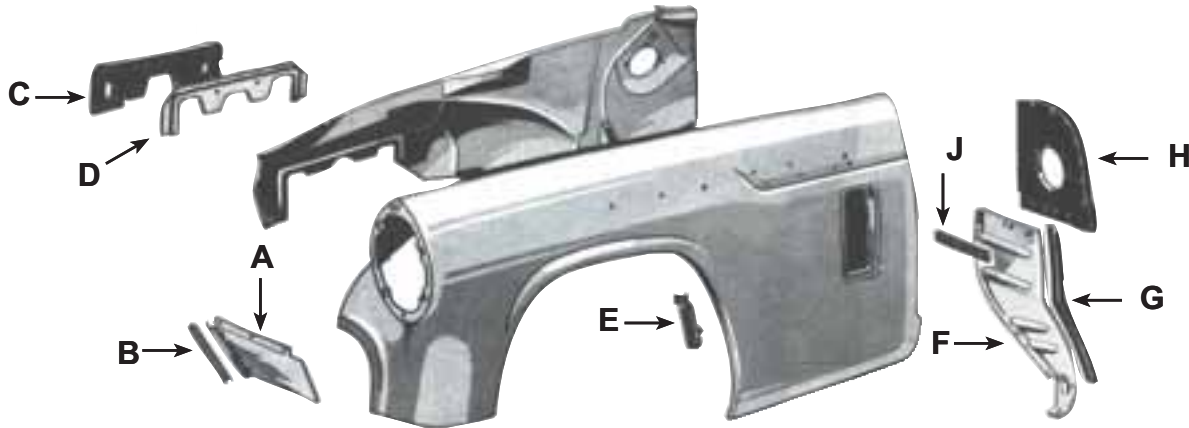

## Body Rubber Kits

With that shiny new paint job on your T-Bird, you will want to replace the rubber parts. Over fifty years of use have probably taken their toll. These kits contain the hood to cowl seal, door seals, dog leg seals, door pillar seals, A-pillar seals, the antenna base grommet, belt weatherstripping, door handle pads, skirt seals, trunk lid seal, trunk lid bumpers, trunk lock cylinder pad & the gas door bumpers. The '56 also has the gas filler neck grommet & both the '56 & '57 have hood bumpers & the vent door seals.

**BUY a KIT & SAVE**

1955	Body rubber kit . . . . .	B5S-0000-KT	212.95 kit
1956	Body rubber kit . . . . .	B6S-0000-KT	225.95 kit
1957	Body rubber kit . . . . .	B7S-0000-KT	215.95 kit

## Hood to Cowl Seals

1955	Requires 7 drive nails (351629-S) listed below . . . . .	B5S-16740-A	4.95
56-57	Requires 7 drive nails (351629-S) listed below . . . . .	B6S-16740-A	5.95
55-57	Drive nails, as original (7 required) . . . . .	351629-S	0.95

## Windshield Seal

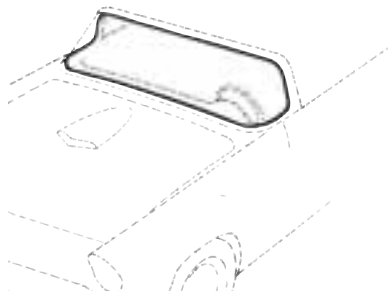

55-57	Windshield seal . . . . .	B5S-4003110-A	40.95
-------	---------------------------	---------------	-------

## A-Pillar Seals

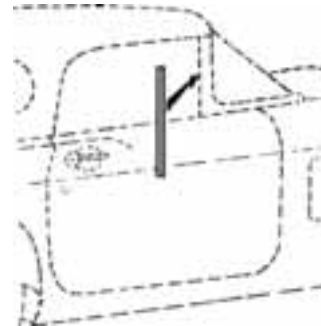

55-57	Right . . . . .	B5S-4002626-A	26.95
55-57	Left . . . . .	B5S-4002627-A	26.95

## Cowl Vent Seals (2 required)



56-57	Vent door seal, molded as original . . . . .	B6S-4002158-C	10.95
56-57	Vent door seal, die-cut sponge . . . . .	.B6S-4002158-DCS	2.95



56-57	Vent screen seal . . . . .	B6S-4002162-B	2.95
56-57	Inner vent seal . . . . .	B6S-4002166-B	2.95



## Front of Door Seal \_\_\_\_\_



55-57 Rubber, mount on door pillar. . . B7S-4020330-PR 6.95 pair

## Door Seal & Door Inner Dog Leg Seal \_\_\_\_\_

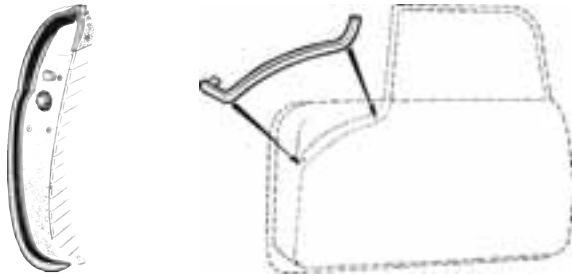

55-57 Door seal rubber . . . . . B5S-4020530-PR 64.95 pair  
55-57 Door inner dog leg seal rubber . . B5S-4020570-PR 5.95 pair

## Door Seal Retainers \_\_\_\_\_

1957 Lock side, right . . . . . B7S-4020572-A 14.95  
1957 Lock side, left . . . . . B7S-4020573-A 14.95

*We carry the best adhesive you can buy to help secure window, door, roof & trunk seals to your car.*



ALL **NEW** Door seal & felt glass channel adhesive, black, 3M brand, 5 oz. tube. . . . . RSP28 8.75



ALL Weatherstrip adhesive, perfect for spongy seals like the one for the trunk, 5 oz. tube . . . . . RSP89 7.95

*To help separate your seals & weatherstripping from the glass, use this! Loosen up tough, hardened old glue & weatherstrip adhesive with this terrific quick release agent. It makes quick & easy work of an otherwise miserable job. Your new weatherstripping will fit better when the old glue build-up is removed. Get rid of that old glue the easy way, with quick release agent from MAC's.*



ALL **NEW** 14 oz. spray can. . . . . RSP958 \* 10.95

\* **HAZARDOUS MATERIAL** can only be shipped by ground/ surface within the U.S. because of government regulations.

## Door Glass Lower Retainer Strip (2 required) \_\_\_\_\_



55-57 Retainer strip. . . . . B5S-21410-A 1.95

## Door Glass Lift Channels \_\_\_\_\_

55-57 Right . . . . . B6S-4021458-A 65.95  
55-57 Left . . . . . B6S-4021459-A 65.95

## Door Glass Retainers (2 required) \_\_\_\_\_



55-56 Rubber, under glass in lift channel . BA-7621478-C 5.95  
1957 Correct cloth-covered material, under glass in lift channel . . . . . B7S-4021478-A 2.95

## Door Glass Run Lining \_\_\_\_\_

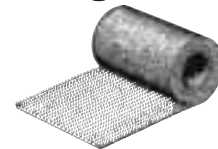

55-57 Moleskin, rear or lock-side glass run, does both sides. . . . . B5S-4021508-L 4.95



**MAC SAYS:** Don't forget adhesive! Our RSP28 is perfect for the job. This rubber & felt adhesive comes in a 5 oz. tube. Best of all it only costs \$8.75! Order your tube TODAY!

## Door Glass Run (2 required) \_\_\_\_\_

55-57 Front . . . . . B5S-4021546-A 22.95

## Belt Weatherstrips \_\_\_\_\_



55-57 Set, original type, inner & outer, clips included. . . . . B5S-4021452-ST 24.95 set  
55-57 Inner, pair . . . . . B5S-4021446-A 9.95 pair  
55-57 Outer, pair, with clips installed. . . B5S-4021452-A 12.95 pair

## Trunk Seal \_\_\_\_\_

55-57 Rubber. . . . . B5S-4043720-A 16.95

## Rear Window Seal \_\_\_\_\_

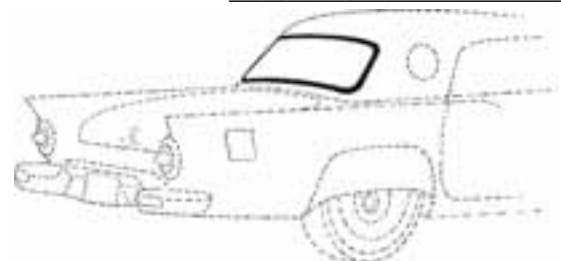

55-57 Rubber. . . . . B5S-4042084-A 39.95





## Hard Top Roof Rail Seal Kits

**BUY a KIT & SAVE**

Until March, 1956, the seal over the door glass was cloth covered & had a dog leg onto the header & onto the deck. After March 1st, 1956, there was no cloth covering over the door glass & there was no longer a dog leg onto the header only the dog leg onto the rear deck remained.

55-56 7 pieces, before 3-1-56 . . . . . B5S-4051222-KT 412.95 kit



56-57 7 pieces, from 3-1-56 (shown) . . B6S-4051222-KT 407.95 kit  
 55-57 T-bolt, for roof rail seals (as required) . . . 35222-S 1.95

## Hard Top Weatherstrips on Deck

55-57 Curved on deck, right . . . . . B6S-4050220-A 41.95  
 55-57 Curved on deck, left . . . . . B6S-4050221-A 41.95  
 55-57 Rear deck center . . . . . B6S-4050298-A 40.95

## Hard Top Seals



55-56 Seal over door glass, has dog leg into the header, right, thru early 1956 . . . . . B6S-4020518-A 100.95  
 55-56 Seal over door glass, has dog leg into the header, left, thru early 1956 . . . . . B6S-4020519-A 100.95  
 55-56 Front header seal, 43-1/2" long, thru early 1956, over the door seals that dog leg onto the header . . . . . B5S-4051330-A 91.95



56-57 Front header seal, 54" long, from late 1956, no over the door seals that dog leg onto the header . . . . . B6S-4051330-A 91.95  
 56-57 Seal over door glass, right, from late 1956 . . . . . B6S-4051222-A 116.95  
 56-57 Seal over door glass, left, from late 1956 . . . . . B6S-4051223-A 116.95

## Soft Top Seals

**BUY a KIT & SAVE**

These kits come with "T" bolts already installed where necessary.



55-57 Complete seal kit, all 10 pieces listed below to seal the top completely (shown) . . . . . B5S-4051502-KT 449.95 kit  
 55-57 Partial seal kit, 6-piece kit to seal over both doors . . . . . B5S-4051562-KT 234.95 kit  
 55-57 Front header seal, 43-1/2" long . . . B5S-4051330-A 91.95  
 55-57 Side rail seal, front, right . . . . . B5S-4051562-R 39.95  
 55-57 Side rail seal, front, left . . . . . B5S-4051563-L 39.95  
 55-57 Side rail seal, center, right . . . . . B5S-4051564-R 39.95  
 55-57 Side rail seal, center, left . . . . . B5S-4051565-L 39.95  
 55-57 Side rail seal, rear, right . . . . . B5S-4051566-R 39.95  
 55-57 Side rail seal, rear, left . . . . . B5S-4051567-L 39.95  
 55-57 Rear seal, curved on deck, right . . B5S-4051444-R 52.95  
 55-57 Rear seal, curved on deck, left . . . B5S-4051445-L 52.95  
 55-57 Rear seal, on deck lid, center . . . . B5S-4051442-A 52.95

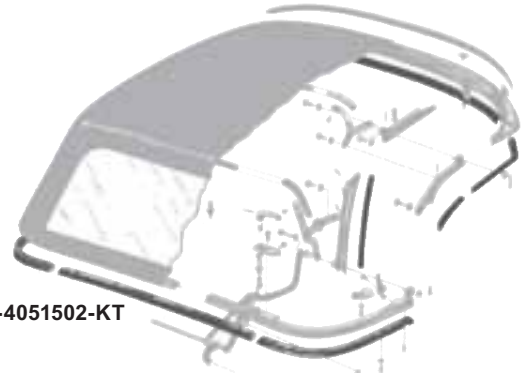

B5S-4051502-KT

## Porthole Glass Seal (2 required)

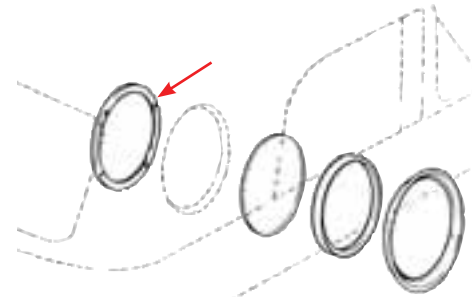

56-57 Rubber . . . . . B6S-4029904-A 3.95

## Hard Top Moulding Weatherstrip



55-57 Fits into the stainless around the bottom of the hardtop . . . . . B5S-4050336-B 17.95



## Scuff Plates



- 55-57 Right (shown) . . . . . B5S-4013208-R 34.95
- 55-57 Left . . . . . B5S-4013209-L 34.95

## Door Pillars & Brackets

- 1955 Right, upper is chromed . . . . . B5S-4020314-C 175.95
- 1955 Left, upper is chromed . . . . . B5S-4020315-C 175.95
- 56-57 Right, upper is chromed . . . . . B6S-4020314-A 175.95
- 56-57 Left, upper is chromed . . . . . B6S-4020315-A 175.95
- 55-57 Upper bracket, right . . . . . B5S-4020320-C 14.95
- 55-57 Upper bracket, left . . . . . B5S-4020321-C 14.95

## Door Lock Button & Grommet (2 required)



- 55-57 Door lock button, chrome . . . . . 0H-7321850 7.95
- 55-57 Grommet . . . . . 8M-7221999 2.95

## Door Lock Button Rod & Clip



- 55-57 Door lock button rod, threaded on upper end for button (2 required) . . . . . B5S-4021852-A 12.95
- 55-57 **NEW** Door latch rod retainer clip (as required) . . . . . B9AB-6421952-A 2.95

## Door Lock Cylinders & Gasket

2 keys are included with each door lock cylinder. Warning: If you buy a right & a left lock cylinder each will have its own coded keys. To get right & left door locks that use the same key, purchase our Door & Ignition Lock Cylinder Set.



- 55-57 Right, includes 2 keys . . . . . B7A-7021984-R 40.95
- 55-57 Left, includes 2 keys . . . . . B7A-7021985-L 40.95
- 55-57 **NEW** **Save** Right & left, includes 2-door lock cylinders, all keyed the same . . . . . B7A-7021984-PR 74.95 pair



- 55-57 Door & Ignition set, includes 2-door lock cylinders & the ignition lock cylinder, all keyed the same plus 2 keys . . . . . B2A-7022050-ST 69.95 set
- 55-57 Door lock cylinder gasket (2 required) . . . . . B3A-22042 1.95

## Door Lock Cover



- 55-57 **NEW** Door lock cover, includes spring, right door only . . . . . B2A-7021942-R 11.95

## Door Lock Cylinder Lever & Spring (2 required)



- 55-57 Lever . . . . . B5S-4021971-A 4.95
- 55-57 Spring . . . . . B7A-7022075-A 0.95

## Door Lock Cylinder Retainer



- 55-57 Door lock cylinder retainers, spring steel . . . . . B5S-4022023-PR 8.95 pair

## Door Latch Spring (2 required)

- 55-57 Door latch spring . . . . . B5S-4021812-A 5.95

## Door Latch Striker Plates & Parts



- 1955 Striker plate, right (above left) . . . . . B5A-7022008-R 16.95
- 1955 Striker plate, left . . . . . B5A-7022009-L 16.95
- 56-57 Striker plate, right (above left center) . . . . . B6AZ-7022008-R 19.95
- 56-57 Striker plate, left . . . . . B6AZ-7022009-L 19.95
- 55-57 Shim, for striker plate, grit surface like original (4 required) (above right center) . . . . . B5A-7022058-B 1.95
- 56-57 Cover, right, for striker plate (above right) . . . . . B7S-4022014-R 14.95
- 56-57 Cover, left, for striker plate . . . . . B7S-4022015-L 14.95
- 56-57 Insert, for striker plate (2 required) . . . . . B7S-4022040-A 14.95

## Door Hinge Parts



- 55-57 Hinge pin, cut to fit (4 required) . . . . . B9A-5943030-AA 3.95
- 55-57 Bushing, for above hinge pin (8 required) . . . . . C3AZ-5422841-B 0.95
- 55-57 Check strap, cadmium plated (2 required) (not shown) . . . . . B5A-7023504-A 9.95



- 55-57 Check strap pin, includes clip (2 required) . . . . . 76001-S8 3.95



## Inside Door Handle Shaft Assemblies

If you can move your inside door handle without unlatching the door, the door handle shaft might be the culprit. 50 years of use takes a toll on the splined shaft & once the splines are worn there is no way to repair them. Now we have a complete assembly to replace your worn out original. Give us a call & we'll be happy to send one your way!



- 55-57 Right ..... B5S-4021818-R 54.95
- 55-57 Left ..... B5S-4021819-L 54.95

## Inside Door Handle Shaft Assembly Return Spring (2 required)



- 55-57 Inside door handle shaft assembly return spring ..... 8A-7021910-C 5.95

## Inside Door Handles (2 required)



- 55-56 Inside door handle, chrome, includes "C" clip. .... B5A-7022600-A 21.95
- 1957 Inside door handle, chrome, includes "C" clip. .... COAZ-6422600-A 22.95

## Window Cranks (2 required)



- 55-56 Window crank handle, chrome, with black knob, includes "C" clip. .... B5A-7023342-AR 28.95
- 55-56 **NEW** Knob only, black ..... 1A-7023352 6.95



- 1957 Window crank handle, chrome, with black knob, includes "C" clip. .... B7A-7023342-AR 28.95
- 1957 **NEW** Knob only, black ..... B7A-7023352-A 4.95

## "C" Clip & Tools



- 55-57 "C" clip, holds window crank handles & door handles on (as required) . . . . .357550-S 0.95
- 55-57 "C" clip tool, makes it easy to remove the "C" clips from your window crank handles ..... TOOL-22600 6.95

## Inside Door Handle & Window Crank Handle Spring (4 required)



- 55-57 Inside door handle & window crank handle spring. .... A48284 0.55

## Inside Door Handle & Window Crank Nylon Plate (as required)



- 55-57 Installs between the handle & the door panel, protects the door panel . . . . . B7A-7023370-B 2.95

## Outside Door Handle (2 required)



- 55-57 Die-cast, chrome, buttons are not included (listed below). .... B7S-4022400-PR 42.95 pair

## Outside Door Handle Button Kits & Parts

- 55-56 Kit, includes buttons, springs, "O" rings & 2 screws ..... B5S-4022454-KT 41.95 kit
- 1957 Kit, includes buttons, springs, "O" rings & 2 screws ..... B7S-4022454-KT 41.95 kit
- 55-57 Spring, for door button (2 required) . BA-7022462-A 1.95
- 55-57 "O" ring, seal for door button (2 required) ..... BAAA-8122478-A 1.95

## Outside Door Handle Pads



- 55-57 **Save** Set, includes right & left large pads & 2 small pads ..... B5S-4022428-ST 4.95 set
- 55-57 Large, right ..... B5S-4022428-R 1.95
- 55-57 Large, left ..... B5S-4022429-L 1.95
- 55-57 Small, right or left (2 required) . . . B5S-4022448-A 1.95





**Power Window Switches** \_\_\_\_\_



1955 Switch, with female terminals, also used for the 4-way power seat . . . . . FAA-14529-A 47.95



1957 Switch, with 3 male terminals, right door uses 1 switch, left door uses 2 switches (as required) . . . . . B7A-14529-B 47.95

**Power Window Switch Backing Plates** \_\_\_\_\_



55-57 On right door, for single switch, cadmium plated (shown) . . . . . B7A-14523-A 7.95  
55-57 On left door, for double switch, cadmium plated . . . . . B7S-14524-A 15.95

**Power Window Switch Bezels, Gaskets & Retainer** \_\_\_\_\_



55-57 Bezel, chrome, on right door, for single switch (shown) . . . . . B5A-14528-B 23.95  
55-57 Bezel, chrome, on left door, for double switch . . . . . B5S-14528-A 28.95  
55-57 Gasket, on right door, for single switch (shown) . . . . . FAA-14554-A 3.95  
55-57 Gasket, on left door, for double switch . . . . . B5S-14616-A 3.95  
55-57 Retainer, V-shaped (as required) (shown) . . . . . FAA-14570-A 3.95

**Power Window Motor Gear Repair Kit** \_\_\_\_\_



55-57 Includes flat gear & new roller bearing, 1 kit repairs 1 motor (as required) . . . . . B5A-70234A24-KT 58.95 kit

**Power Window Motor Mounting Grommets** (as required) \_\_\_\_\_

55-57 Grommets . . . . . 14553-GROMMET-PR 1.95 pair

**Power Window Regulator to Drive Assembly Coupling** (2 required) \_\_\_\_\_



55-57 Exactly like the original, nylon plastic with flattened shaft indentations on both ends & a rubber sleeve . . . . . B5A-7023440-A 14.95

**Window Roller Assembly** (6 required) \_\_\_\_\_

*These rollers attach to the end of the window regulator arms. They slide back & forth in the window channels inside the door, allowing the window to go up & down smoothly. If your window tilts forward or back, or isn't level when you roll it up, a broken or damaged roller might be the cause.*



55-57 For power or manual windows . . . . . BA-7023240-A 3.95

**Window Regulator Springs** (2 required) \_\_\_\_\_

55-57 For manual regulator . . . . . B5S-23318-M 8.95  
55-57 For power regulator . . . . . B5S-23318-P 8.95

**Manual Window Regulators** \_\_\_\_\_

55-57 Right, zinc plated . . . . . B7S-4023202-A 89.95  
55-57 Left, zinc plated . . . . . B7S-4023203-A 89.95

**Door Glass Stops** (2 required) \_\_\_\_\_



55-57 Upper, bracket with rubber tip . . . . . B5S-4021770-A 4.95  
55-57 Lower, hard rubber block . . . . . B5A-7021762-A 1.95



## Grilles



- 55-56 **NEW** OS Grille . . . . . B5S-8200-AR 345.95
- 1957 **NEW** OS Grille, shown with bumper . B7S-8200-AR 347.95

## Grille Mouldings

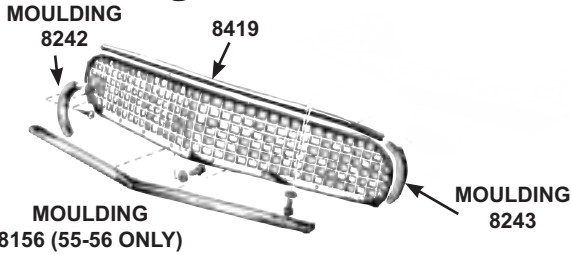

- 55-56 Right . . . . . B5S-8242-B 39.95
- 55-56 Left . . . . . B5S-8243-B 39.95
- 55-56 Upper . . . . . B5S-8419-AR 57.95
- 55-56 Lower . . . . . B5S-8156-AR 83.95
- 1957 Right . . . . . B7S-8242-AR 51.95
- 1957 Left . . . . . B7S-8243-AR 51.95
- 1957 Upper . . . . . B7S-8419-AR 59.95
- 1957 Lower, chrome . . . . . B7S-17202-B 143.95

## Upper Grille Panel Nameplates & Ornament



- 1955 Nameplate, plastic insert for ornament . . . . . BM-7325662-B 28.95
- 1955 Nameplate bezel, chrome . . . . . B6A-7925666-C 36.95
- 1955 Ornament, crossed flags . . . . . B5S-4042550-A 13.95
- 55-57 Emblem pad, for plastic insert . . . . . 1A-7004541 0.95



- 56-57 Nameplate, plastic insert for ornament . B6S-8218-A 19.95
- 56-57 Nameplate bezel, chrome . . . . . B6S-8259-B 35.95

## Headlight Door Trim (2 required)

For 1955, the full size Ford had trim on the headlight doors that was exclusive to the Fairlane model. Many T-Bird aficionados love the way it looks & want to add it to their Little Birds. Now anybody can, simply & easily with this new reproduction of the original trim. The details are just right, the chrome plating looks as deep as the ocean & the black painted areas look like they were applied at the factory! If you want to make your Bird a conversation starter, call us today & place an order for our new Headlight Door Trim!



- 1955 **NEW** Die-cast, chrome plated with black painted accents . . . . . B5A-13063-E 78.95

## Hood Scoop Grille & Stud Spacer



- 55-57 Hood scoop grille . . . . . B5S-16607-A 72.95
- 55-57 Hood scoop grille stud spacer (4 required) . . . . . B5S-16873-A 1.95

## Windshield Moulding Attaching Parts

- 55-57 Moulding clip, used on upper mouldings (7 or 8 required) . . . . . B6S-4003180-A 3.95
- 55-57 Moulding clip, used to connect vertical moulding to horizontal moulding (as required) . . . . . B5S-4003138 4.95
- 55-57 Moulding retainers . . . . . B6S-4003178-PR 19.95 pair

## Windshield Moulding Joint Covers

- 1955 Windshield outer moulding joint cover (3 required) . . . . . B5S-4003094-A 7.95
- 56-57 Windshield outer moulding joint cover (3 required) . . . . . B6S-4003094-A 7.95
- 55-57 Joint cover, windshield lower garnish moulding, inside at center . . . . . B5S-4003654-A 13.95

## Soft Top Moulding

- 56-57 Stainless steel one piece design, can be used on 1955 as a one piece replacement . . . . . B6S-4051390 209.95

## Fender Nameplate, Ornaments, Emblems & Parts



- 1957 Fender nameplate, "Thunderbird," requires (5) 375890-S to mount (2 required) . . . . . C1SB-16098-A 24.95



- 1957 **NEW** Fender nameplate, this one is exactly like the original with 4 studs on the back for mounting . . . . . B7S-16098-A 28.95



- 55-57 Fender ornament "hash marks," right . . . . . B5A-16228-A 29.95
- 55-57 Fender ornament "hash marks," left . . . . . B5A-16229-A 29.95



- 1956 Emblem bezel requires (2) 375890-S to mount (2 required) . . . . . B6A-7925666-C 36.95
- 1956 Emblem, used on fenders & hard top (2 required) . . . . . BM-7325662-B 28.95
- 1955 Fender emblem, Y-block "V-8" (2 required) . . . . . BM-16237-A 17.95



- ALL Emblem barrel clip . . . . . 375890-S 0.60



# EMBLEMS & MOULDINGS

## Dash Nameplate & Emblem



55-56 Nameplate, "Thunderbird" on dash, very early production 1955s had this mounted on the ashtray door, 1956 models with optional dash pad did not use this nameplate . . . B5S-4004460-A 22.95

## Glovebox Emblem



55-56 Y-block "V-8," with threaded stud & nut . . . . . B6A-7004407-A 13.95

## Roof Emblems & Bezels



55-56 Emblem, plastic (2 required) . . . . . BM-7325662-B 28.95  
 55-56 Emblem bezel, chrome, requires (2) 375890-S to mount (2 required) . . . . . B6A-7925666-C 36.95  
 55-56 Pad, for roof emblem plastic insert (2 required) . . . . . 1A-7004541 0.95



1957 Roof emblem, plastic, tops without portholes (2 required) . . . . . B7S-4050270-A 24.95  
 1957 Roof emblem bezel, chrome, tops without portholes (2 required) . . . . . B7S-4050292-A 16.95



ALL Emblem barrel clip . . . . . 375890-S 0.60

## Rear Garnish Rail Mouldings

55-57 Rear garnish rail mouldings, right & left . . . . . B5S-4040408-PR 89.95 pair  
 55-57 Rear garnish rail moulding joint cover . . . . . B5S-4040406-B 10.95

## Rear Window Mouldings

55-57 Complete set, stainless steel . . . B5S-4042430-ST 312.95 set  
 55-57 Right, stainless steel . . . . . B5S-4042430-A 176.95  
 55-57 Left, stainless steel . . . . . B5S-4042431-A 176.95  
 55-57 Joint cover (2 required) . . . . . B4A-7042450-A 9.95

## Fender Skirt Mouldings

55-56 Right . . . . . B5S-4029164-A 72.95  
 55-56 Left . . . . . B5S-4029165-A 72.95  
 1957 Right . . . . . B7S-4029164-B 72.95  
 1957 Left . . . . . B7S-4029165-B 72.95

## Fender Skirt Stone Guard & Bracket



55-57 Stone guards, stainless steel, with brackets, pair . . . . . B5S-4025648-PR 108.95 pair  
 55-57 Stone guard bracket, can be used right or left (2 required) . . . . . B5S-4025650 4.95

## Quarter Panel Nameplate (2 required)



55-56 "Thunderbird" . . . . . B5S-4025622-B 26.95

## Trunk Lid Handle Insert & Emblem



1957 Trunk handle insert, plastic nameplate, fits in trunk lid handle . . . . . B7S-4042530-A 16.95

## Gas Door Emblem, Insert & Bezel



1955 Emblem, crossed flags . . . . . B5S-4042550-A 13.95  
 55-56 Emblem insert, plastic . . . . . BM-7325662-B 28.95  
 55-56 Emblem bezel, Ford crest, chrome . . . . . B5S-4025666-A 22.95

## Hard Top Mouldings

55-57 Front header moulding . . . . . B5S-4051724-B 113.95  
 55-57 Over door, right . . . . . B5S-4051700-B 93.95  
 55-57 Over door, left . . . . . B5S-4051701-B 93.95  
 55-57 Corner, behind over door moulding, right, not used in early '55. . . . . B5S-4051732-A 41.95  
 55-57 Corner, behind over door moulding, left, not used in early '55. . . . . B5S-4051733-A 41.95  
 55-57 Right rear . . . . . B5S-4050396-B 113.95  
 55-57 Left rear . . . . . B5S-4050397-B 113.95  
 55-57 Joint cover. . . . . B5S-4050390-A 8.95

## BUY the SET & SAVE

55-57 Complete 8-piece set . . . . . B5S-4050200-ST 575.95 set

## Emblem Hardware (as required)

These are the clips that fit into holes in the sheet metal & secure the pins on ornaments.



ALL Barrel clip, .062" . . . . . 378362-S 0.50  
 ALL Barrel clip, .120" . . . . . 375890-S 0.60  
 ALL Barrel clip, .180" . . . . . 375480-S 0.75





## Fenders

The fender bottom rear patch panel, below, repairs the area from the outer rocker 28" forward & is 10-1/4" high. On 1956-1957 models it fits just below the vent door. This panel is flanged at the door opening & has a mounting plate for the fender bracket.



- 55-57 Fender bottom rear patch panel, right, see illustration (U) . . . . . B5S-16005-R 53.95
- 55-57 Fender bottom rear patch panel, left, see illustration (U) . . . . . B5S-16005-L 53.95

The fender panel section, below, repairs the fender from the rear, approximately 22-1/2" forward from the door. It goes to the top crease & includes the lip where the panel meets the door.

- 1955 Fender panel section, right, see illustration (V) . . . . . B5S-16006-R 272.95
- 1955 Fender panel section, left, see illustration (V) . . . . . B5S-16006-L 272.95
- 56-57 Fender panel section, right, see illustration (V) . . . . . B6S-16006-R 336.95
- 56-57 Fender panel section, left, see illustration (V) . . . . . B6S-16006-L 336.95

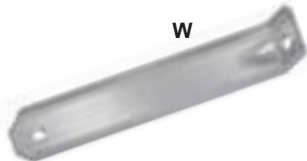

- 55-57 Fender to apron brace, right or left, see illustration (W) (2 required) . . . B5S-16222-A 7.95

The lower front fender panel fits at the bottom of the front fender behind the bumper mounted parking light (below the headlight).

- 55-56 Lower front fender repair panel, right, see illustration (X) . . . . . B5S-13202-R 91.95
- 55-56 Lower front fender repair panel, left, see illustration (X) . . . . . B5S-13202-L 91.95



- 1957 Lower front fender repair panel, right, see illustration (X) (shown) . . . . . B7S-13202-R 112.95
- 1957 Lower front fender repair panel, left, see illustration (X) . . . . . B7S-13202-L 112.95
- 55-57 Grommet, solid—no hole in center, for cars that don't have a radio . . . . B5S-18912 4.95

## Lower Air Deflector & Inspection Plate

- 1957 Lower air deflector, fiberglass . . . . . B7S-8310-F 73.95
- 55-57 Lower air deflector inspection plate . . . B5S-8311-A 5.95

## Fender Splash Shields



- 55-57 Right front, lower bolts to fender next to frame (shown) . . . . . B5S-16102-R 14.95
- 55-57 Left front, lower bolts to fender next to frame . . . . . B5S-16103-L 14.95

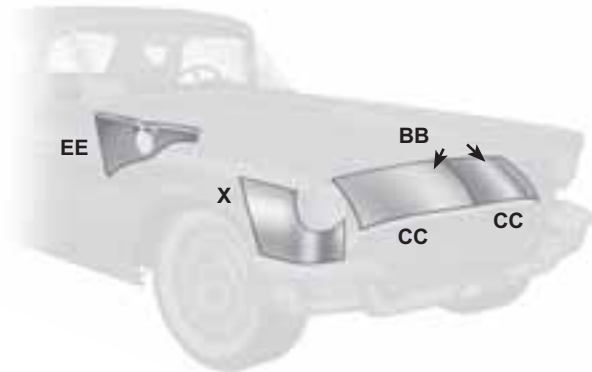

## Nose Panels

- 55-57 Nose panel reinforcement . . . . . B5S-8223 121.95
- 55-57 **OS** See illustration (BB) . . . . . B5S-8214 380.95
- 55-57 Right half, see illustration (CC) . . . . . B5S-8214-R 160.95
- 55-57 Left half, see illustration (CC) . . . . . B5S-8214-L 160.95

## Fender Aprons

The fender apron repairs the front fender apron area next to the battery box on the left side & next to the heater duct on the right side.

- 55-57 Fender apron, right, see illustration (EE) . . . . . B5S-16054-R 120.95
- 55-57 Fender apron, left, see illustration (EE) . . . . . B5S-16054-L 120.95

## Rocker Panels

The inner rocker panels, below, replace the area inside the outer rocker panel, from the rear wheel well opening to the bottom of the door post. These panels weld to the floorpan & the floor braces.



- 55-57 Inner, right (shown) . . . . . B5S-11135-R 53.95
- 55-57 Inner, left . . . . . B5S-11135-L 53.95

The outer rocker panels, below, run from the fender to the quarter panel. These panels have the correct curves at the outside & include the original type drain holes.



- 55-57 Outer, right, see illustration (J) (shown) . . . . . B5S-13208-R 84.95
- 55-57 Outer, left, see illustration (J) . . . . . B5S-13208-L 84.95
- 55-57 Outer, right, economy version . . . B5S-13208-RECO 42.95
- 55-57 Outer, left, economy version . . . B5S-13208-LECO 42.95



## Door Panels

The door posts, below, repair the area of the door that is behind the fender.

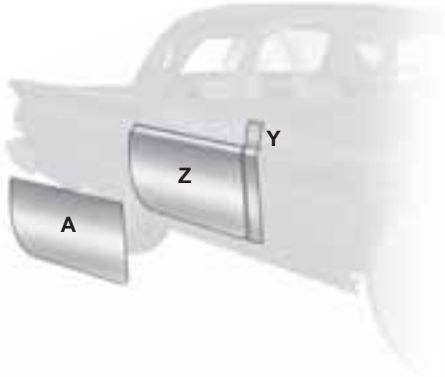

55-57	Lower door post, right . . . . .	B5S-02500-R	70.95
55-57	Lower door post, left . . . . .	B5S-02500-L	70.95
55-57	Door post, full height, right, see illustration (Y) . . . . .	B5S-02501-R	90.95
55-57	Door post, full height, left, see illustration (Y) . . . . .	B5S-02501-L	90.95
55-57	Doorskin repair panel, right, see illustration (Z) . . . . .	B5S-20200-R	256.95
55-57	Doorskin repair panel, left, see illustration (Z) . . . . .	B5S-20200-L	256.95
55-57	Lower doorskin, right, see illustration (A) . . . . .	B5S-20201-R	98.95
55-57	Lower doorskin, left, see illustration (A) . . . . .	B5S-20201-L	98.95

## Kick Panels

55-57	Lower 7-1/2" below vent door opening . . . . .	B5S-02042-CR	64.95
55-57	Lower 7-1/2" below vent door opening . . . . .	B5S-02042-CL	64.95

## Floor Pans

The front floor pan, below, replaces the area under the driver's & passenger's feet. These panels run from the inner rocker to the bottom of the transmission tunnel & back 22-1/2" from the factory seam at the base of the firewall. All grooves are stamped in the proper places. These panels are stamped from 19 gauge steel.



55-57	Front floorpan, stamped from 19 gauge steel, right . . . . .	B5S-11136-R	117.95
55-57	Front floorpan, stamped from 19 gauge steel, left . . . . .	B5S-11136-L	117.95



55-57	Rear floorpan, stamped from 19 gauge steel, right . . . . .	B5S-11137-RF	128.95
55-57	Rear floorpan, stamped from 19 gauge steel, left . . . . .	B5S-11137-LF	128.95



55-57	Rear floorpan, outer half, stamped from 19 gauge steel. . . . .	B5S-11137-RH	96.95
55-57	Rear floorpan, outer half, stamped from 19 gauge steel. . . . .	B5S-11137-LH	96.95

The firewall sections below replace the area from the bottom of the firewall, where they meet the floorpan, up 10" & from the transmission tunnel to the inner fender apron. All the grooves are stamped in the proper place.



55-57	Firewall section, right . . . . .	B5S-11134-R	56.95
55-56	Firewall section, left. . . . .	B5S-11134-L	56.95
1957	Firewall section, left (not shown). . . . .	B7S-11134-L	80.95

The floor braces below are welded to the inner rocker panel & the floorpan. They are each stamped from one piece of steel.

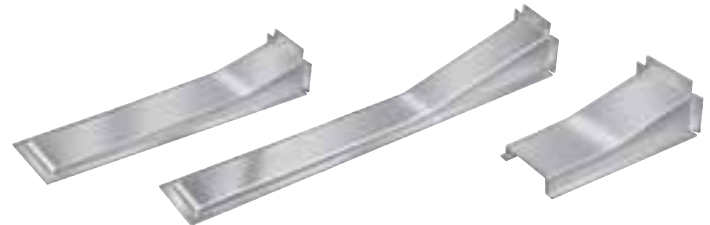

55-57	Front floor braces (2 required) . . . . .	B5S-11138	44.95
55-57	Center floor braces (2 required) . . . . .	B5S-11139	44.95
55-57	Rear floor braces (2 required) . . . . .	B5S-11140	35.95

## BUY the SET & SAVE

55-57	<b>NEW</b> <b>Save</b> Floor brace set, includes 2 front, 2 center & 2 rear floor braces . . . . .	B5S-11138-ST	246.95 set
-------	----------------------------------------------------------------------------------------------------------	--------------	------------

## Floor Panels

The center floor sections, below, repair the floorpan between the front & rear floor repair panels, just under the seats. This panel measures 6" x 23". It is stamped from 19 gauge steel.



55-57	Center floor section (shown). . . . .	B5S-11141-R	56.95
55-57	Center floor section. . . . .	B5S-11141-L	56.95

55-56	Floor & cowl plug set, 10 pieces. . . . .	B5S-11135-ST	14.95 set
1957	Floor & cowl plug set, 11 pieces. . . . .	B7S-11135-ST	16.95 set



## Quarter Panel Sheetmetal

The quarter panel repair panels listed below replace the area from 1" below the feature line. This rocker panel includes the correct lip at the wheel opening. It also meets the outer rocker panel & takes the first bend into the door jamb. This panel replaces the bottom rear of the quarter panel, which can be trimmed.



- 55-57 **NEW 05** Quarter panel repair panel, right . . . . . B5S-27840-R 217.95
- 55-57 **NEW 05** Quarter panel repair panel, left . . . . . B5S-27840-L 217.95
- 55-57 Tab set, 4 pieces, weld to new quarters so you can install skirts . . . . . B5S-27976-ST 1.95 set

## Quarter Panel Drain Plug Set

- 55-57 Quarter panel drain plug set, 4 pieces, includes 2 buttons & 2 drain plugs . . . . . B5S-11135-QPST 6.95 set

## Quarter Panel Sheetmetal

The dog leg repair panels listed below replace the area of the quarter panel from the outer rocker panel to the wheel opening. This panel includes the lip at the wheel opening & the lip at the door jamb.



- 55-57 Dog leg repair panel, right . . . . . B5S-27843-R 65.95
- 55-57 Dog leg repair panel, left . . . . . B5S-27843-L 65.95

The bottom rear quarter patch panels listed below replace the area behind the rear wheels & include the lip at the rear of the wheel opening.



- 55-57 Bottom rear quarter patch panel, right . . . . . B5S-27846-R 91.95
- 55-57 Bottom rear quarter patch panel, left . . . . . B5S-27846-L 91.95

The lower front wheelhouses listed below replace the area of the outer wheelhouse behind the quarter panel dog leg.



- 55-57 Lower front wheelhouse, right . . . . . B5S-27882-R 50.95
- 55-57 Lower front wheelhouse, left . . . . . B5S-27882-L 50.95

The wheelhouse top caps, below, replace the area of the wheelhouse above the wheel.



- 55-57 Wheelhouse top cap, right . . . . . B5S-27884-R 51.95
- 55-57 Wheelhouse top cap, left . . . . . B5S-27884-L 51.95

The rear wheelhouse extensions, below, replace the area of the wheelhouse behind the rear wheel. These panels meet the rear lip of the quarter & extend to the rear of the quarter, which welds to the trunk floor.



- 1955 Rear wheelhouse extension, right . . . B5S-27885-R 108.95
- 1955 Rear wheelhouse extension, left . . . B5S-27885-L 108.95
- 1956 Rear wheelhouse extension, right . . . B6S-27885-R 95.95
- 1956 Rear wheelhouse extension, left . . . B6S-27885-L 95.95
- 1956 **NEW** Rear wheelhouse extension shelf, right . . . . . B6S-27884-R 46.95
- 1956 **NEW** Rear wheelhouse extension shelf, left . . . . . B6S-27884-L 46.95
- 1957 Rear wheelhouse extension, right . . . B7S-27885-R 95.95
- 1957 Rear wheelhouse extension, left . . . B7S-27885-L 98.95



Panel adhesives have received a lot of attention in the last few years. Research indicates that use of panel adhesives on any of our metal products is not recommended. We do recommend MIG welding for proper installation. See your local welder supplier for details.





**Trunk Floor & Parts**



55-56 **OS** Trunk floor pan, repairs the center trunk floorpan over the gas tank. . . . .B5S-11215 432.95



1957 Trunk brace (shown) . . . . .B7S-27800-F 192.95

1957 Trunk half-brace . . . . .B7S-27800-H 112.95

55-56 Brace, trunk floor to rear body panel. . . . . B5S-11215-BRC 24.95

55-57 Panel, for fuel tank sending unit access, stamped steel . . . . .B5A-7011290 10.95

**Fender Skirt Stone Guards**



55-57 Fender skirt stone guards, stainless steel, with brackets .B5S-4025648-PR 108.95 pair

**Stone Guard Bracket (2 required)**

55-57 . . . . .B5S-4025650 4.95

**Fender Skirts**



55-57 Fender skirts, mouldings listed on page 83 . . . . . B7S-4027974-PR 325.95 pair

**Fender Skirt Bracket Set**

55-57 Fender skirt bracket set, 4 pieces. . . . .B5S-4027980-ST 30.95 set

**Fender Skirt Seals**



55-57 Fender skirt seals . . . . . B7S-4027986-PR 10.95 pair

55-57 Fender skirt seal staple kit for above . . . . .B7S-4027986-KT 2.95 kit

**Here are some books to ease your installation . . .**

ALL **Sheetmetal Handbook**, by Ron & Sue Fornier, shows you how to form & shape sheet metal using hammer forming, riveting, layout, design & pattern-making, 144 pages . . . . .BK575 16.95



ALL **Metal Fabricator's Handbook**, by Ron & Sue Fornier, over 350 step-by-step photos & instructions teach proper welding, metal shaping & design techniques for bodywork, fuel & oil tanks & exhaust headers, 175 pages . . . . .BK709 16.95



ALL **Welder's Handbook**, by Richard Finch, the complete guide to MIG, TIG, oxyacetylene, & arc welding, weld like the pros! Sections include brazing, cutting, soldering, plasma cutting master materials like mild steel, aluminum, chrome-moly, magnesium & titanium, 170 pages . . . . .BK1264 19.95

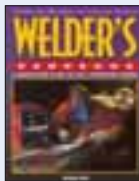

ALL **Performance Welding**, by Richard Finch, this guide covers techniques used for Indy, NASCAR & experimental aircraft, your guide to high-quality welds with 4130 steel, aluminum & stainless, how to select equipment & choose the right process & fill metal for each project, 160 pages, 250 illustrations . . . . . BK530AP 18.95





## A

<b>Accelerator</b>	
Bellcranks	49
Pedal & Rod	49
Rod	49
Rod to Floor Seal	49
<b>Accessories</b>	95-129
<b>Additives</b>	116
<b>Adhesives</b>	116
<b>Adjusting Springs, Brake Shoe</b>	24
<b>Adjustment Hole Plug, Brake</b>	24
<b>Air Cleaner Assembly</b>	49
Carburetor Stud	49
Cork Seal Staple Kit	49
Cover Gasket	49
Hood Seal	49
Wing Nut	49
<b>Air Cleaner Service Instructions</b>	98
<b>Air Cleaner, Carburetor Top Gasket</b>	49
<b>Air Filter</b>	40
<b>Air Valve Damper Door Assembly</b>	75
<b>Air Vent to Heater Blower Housing</b>	
Connecting Duct	74
<b>Alignment Shims</b>	31
<b>Alternator</b>	50
<b>Alternator Installation Kit</b>	50
<b>AM/FM Cassette Stereo</b>	18
<b>Antenna Mounting Pad &amp; Base</b>	20
<b>Antenna, Radio</b>	20
<b>Antenna Toppers</b>	121
<b>Antique Car Information Books</b>	111
<b>A-pillar Seals</b>	76
<b>Armrest</b>	
Base	10
Covers	9
Foam	10
<b>Automatic Choke Control Tube</b>	49
<b>Automatic Choke Control Tube Insulator</b>	49
<b>Automatic Choke Housing Gasket</b>	49
<b>Automatic Transmission Lock</b>	112
<b>Automatic Transmission Parts</b>	43
Dipstick & Tube	43
Extension Housing Bushing	43
Extension Housing Seal	43
Manual Control Lever Oil Seal	43
Pan Gasket	43

## B

<b>Backrest Panels, Seat</b>	3
<b>Back-up Light Parts</b>	58
Housing	58
Housing Reflector	58
Housing to Body Gasket & Blank-off Plate Pad	58
Lens	58
Lens to Housing Gasket	58
Socket & Pigtail	58
Switch & Actuator	42
Wires	61
<b>Baffle, Water Pump</b>	45
<b>Ball Joints</b>	32
<b>Ball Stud Shield, Control Valve</b>	31
<b>Base Gaskets, Carburetor</b>	48
<b>Baseball Caps</b>	129
<b>Batteries</b>	51
Cable Bracket & Grommet	52
Cables & Sets	52
Disconnect Switches	112

Heat Shield	52
Hold-down Bolt	51
Hold-down Clamp	51
Hold-down to Inner Fender Panel Bracket	51
Mat	112
Tender	115
Tray	51
<b>Bearing &amp; Race, Differential</b>	33
<b>Bellcrank, Accelerator</b>	49
<b>Belts</b>	45
Adjustment Arm, Generator	50
Fan	45
Fan to Generator	45
Power Steering	45
<b>Bezel Retainer Nut, Ignition Switch</b>	63
<b>Bezels, Dash</b>	63
<b>Blackwall Tires</b>	28
<b>Bleeder Screw, Wheel Cylinder</b>	26
<b>Blower Housing Connecting Duct, Air Vent to Heater</b>	74
<b>Blower Motor</b>	
Fan, Heater	74
Switch, Heater	65 & 74
to Housing Grommet, Heater	74
<b>Body Parts</b>	84-87
<b>Body Rubber Kits</b>	76
<b>Body to Fender Pad, Parking Light</b>	56
<b>Body to Frame Mounting Parts</b>	41
<b>Bolts, Bumper</b>	73
<b>Books &amp; Manuals</b>	103-111
<b>Bracket</b>	
Cover Insulator, Steering Column	29
Set, Fender Skirt	87
Stone Guard	87
<b>Brake "C" Clip</b>	24 & 27
<b>Brake</b>	23-27
Booster Parts, Power	26
Cable, Front Emergency	27
Cable, Rear Emergency	27
Drums	23
Grease Baffle Gasket, Front	23
Hoses	25
Light Switch	24 & 65
Line Gasket	25
Line Kit	25
Overhaul Kit	23
Pedal Bushing	24
Pedal Pads	24
<b>Brake Shoe</b>	
Adjusting Springs	24
Adjustment Hole Plug	24
"C" clip	24
Hold-down Kit	24
Relined Brake Shoes	24
Return Springs	24
Self-adjuster Assembly	24
to Cylinder Link	24
<b>Breather Screen</b>	26
<b>Brookland Road Test Books</b>	109
<b>Bucket Spring, Headlight</b>	56
<b>Bucket to Fender Gasket, Headlight</b>	56
<b>Bulb Pigtail, Headlight</b>	56
<b>Bulk Wire</b>	61
<b>Bullet Splice -180°</b>	61
<b>Bumper Parts</b>	73
Bolts	73
Bracket	73
Braces, Rear	73

End Braces, Front	73
Guard Sleeve & Spacer Kit	73
to Rear Frame Crossmember	73
<b>Bumper Set, Hood</b>	67
<b>Bumper Stickers</b>	102
<b>Bumper, Rear Axle</b>	33
<b>Bumper, Rubber Wheel</b>	21
<b>Bumpers, Control Arm</b>	33
<b>Bumpers, Gas Tank Door</b>	47
<b>Bushings, Control Arm</b>	32
<b>Bushings, Stabilizer Bar</b>	32

## C

<b>"C"-Clip, Brake</b>	24 & 27
<b>Cable</b>	
& Housing, Tachometer	64
Clip, Emergency Brake	27
Sets, Battery	52
Speedometer	63
<b>California Car Duster</b>	113
<b>California Mini-duster</b>	113
<b>Cam Bearing Set</b>	36
<b>Camshaft</b>	36
Thrust Plate	36
<b>Canceling Cam Turn Signal Switch</b>	64
<b>Cap</b>	
Distributor	55
Gas	46
Radiator	44
<b>Caps &amp; Patches</b>	129
<b>Carburetor</b>	
Books	108
Base Gaskets	48
Choke Cover Gaskets	48
Dashpot Bracket	48
Fuel Line, Fuel Pump to	47
Rod, Choke Housing to	48
Secondary Vacuum Diaphragm	48
Top Gasket	49
Tune-up Kits	48
<b>Car Covers</b>	114-115
<b>Carpets</b>	6
<b>Case Gaskets, Heater</b>	74
<b>Car Show Supplies</b>	113
<b>CD Changer</b>	18
<b>Charging</b>	51-52
<b>Choke Housing Gasket, Automatic</b>	49
<b>Choke Housing to Carburetor Rod</b>	48
<b>Cigar Lighter</b>	65
<b>Clamp Lever, Rear</b>	12
<b>Clamp Retaining Plate, Rear</b>	13
<b>Clamp, Heater Hose</b>	75
<b>C-line, Power Brake Booster</b>	26
<b>Clock Faces</b>	62
<b>Clock Feed Wire</b>	61
<b>Clock Instruction Booklet</b>	101
<b>Clutch Parts</b>	42
Arm Return Spring	42
Disc & Pressure Plate	42
Fork Boot	42
Pilot Bearing	42
Release Equalizer Shaft Parts	42
Throwout Bearing	42
<b>Coil Spring Insulator, Front</b>	34
<b>Coil Spring Spacer, Front</b>	34
<b>Coil Springs, Front</b>	34
<b>Condenser, Distributor</b>	55
<b>Connecting Rod Bearings</b>	36
<b>Connecting Sleeve, Tie Rod</b>	28



<b>Continental Kit Parts</b> .....	<b>22</b>
<b>Control Arm</b>	
Bumpers .....	32
Bushings .....	32
Shaft & Bushing Kits .....	32
<b>Control</b>	
Assembly, Vent .....	75
Bezel & Face Plate, Heater .....	74
Cable, Heater .....	74
Knob, Wiper .....	70
Lever, Heater .....	74
Valve to Power Cylinder Line, Power Steering .....	31
Valve to Pump Return Line, Power Steering .....	31
<b>Conversion Kit, Oil Filter Canister</b> .....	<b>38</b>
<b>Convertible Parts</b> .....	<b>11-13</b>
Seals .....	78
Tops .....	11
Top Frame Pin Kit .....	11
Top Locating Pin .....	11
Top Tacking Strip .....	11
Top Moulding .....	82
Top Protectant .....	119
<b>Convertible Tops</b>	
Header Trim Retainers .....	11
Top Swing Bars & Parts .....	12
Top Tack Strip Channel .....	11
<b>Cooling</b> .....	<b>44-45</b>
<b>Core, Heater</b> .....	<b>74</b>
<b>Cover Gasket, Rear Axle</b> .....	<b>33</b>
<b>Covers, Car</b> .....	<b>114-115</b>
<b>Cowl &amp; Firewall</b> .....	<b>68</b>
<b>Cowl Parts</b> .....	<b>68</b>
Side Vent Door Spring .....	68
Side Vent Screen .....	68
Side Ventilator Grille .....	68
Side Ventilator Hinge Assembly .....	68
Vent Knob .....	68
<b>Cowl Wiring</b> .....	<b>60</b>
<b>Crankshaft Harmonic Balancer</b>	
<b>Repair Sleeve</b> .....	<b>37</b>
<b>Crossmember Braces</b> .....	<b>73</b>
<b>Crossover Wiring</b> .....	<b>60</b>
Headlight .....	60
Parking Light .....	60
Turn Signal .....	60
<b>Cylinder Sleeve</b> .....	<b>36</b>

## D

<b>Damper Door Assembly, Air Valve</b> .....	<b>75</b>
<b>Dash Bezel Tool</b> .....	<b>112</b>
<b>Dash Emblem</b> .....	<b>62 &amp; 83</b>
<b>Dash Nameplate</b> .....	<b>62 &amp; 83</b>
<b>Dash</b> .....	<b>62-65</b>
Bezels .....	63
Gauge Lens .....	62
Gauge Trim Rings .....	62
Nameplate & Emblem .....	62 & 83
Noddors .....	121
Pad Finish Panels .....	62
Pad Retainer Strip Set .....	62
Pads .....	62
Trim .....	62
<b>Dashpot Bracket, Carburetor</b> .....	<b>48</b>
<b>Decal Kits</b> .....	<b>96</b>
<b>Decals &amp; Tags</b> .....	<b>96-102</b>
Air Cleaner .....	98
Engine Compartment .....	98-100

Ford .....	101
Interior .....	100-101
Nostalgia .....	101-102
Trunk Decals .....	100

### Deflector Mushroom, Automatic Choke

<b>Air Intake</b> .....	<b>49</b>
<b>Defroster Nozzle Seal</b> .....	<b>75</b>
<b>Detailing &amp; Trim Books</b> .....	<b>107</b>
<b>Dial, Speedometer Face</b> .....	<b>63</b>
<b>Differential Bearing &amp; Race</b> .....	<b>33</b>
<b>Differential Spider Gear Kit</b> .....	<b>33</b>
<b>Differential Ring &amp; Pinion</b> .....	<b>33</b>
<b>Dimmer Switch, Headlight</b> .....	<b>64</b>
<b>Dipstick</b>	

& Tube, Automatic Transmission .....	43
Oil .....	38
<b>Distributor Parts</b> .....	<b>55</b>
Cap .....	55
Condenser .....	55
Gear Pin .....	55
Hold-down Clamps & Rivets .....	55
Point Sets .....	55
Rotor .....	55
Shaft Seal .....	55
Tune-up Kits .....	55
Vacuum Advance & Line .....	55
<b>Dome Light Wiring</b> .....	<b>60</b>
<b>Dome, Speedometer</b> .....	<b>63</b>
<b>Door</b>	

Arm, Glovebox .....	65
Emblems, Gas .....	83
Finish Panel, Glovebox .....	65
Garnish Finish Plates .....	9
Garnish Rail Moulding .....	9
Garnish Rail Vinyl Sets .....	9
Garnish Rails .....	9
Glass .....	69
Glass Lift Channels .....	77
Glass Lower Retainer Strip .....	77
Grommets & Bumpers, Glovebox .....	65
Hinge Parts .....	79
Latch Guide Plate, Glovebox .....	65
Lock Buttons .....	79
Lock Cylinders .....	79
Lock Push button Bezel, Glovebox .....	65
Panels .....	85
Parts .....	79-81
Pillars & Bracket .....	79
Striker, Glovebox .....	65
Trim Panel, Upper .....	10
Trim Panels .....	10

### Door Handle

Button & Spring, Outside .....	80
Door Handle Nylon Plate .....	80
Pad Set, Outside .....	80
Removal Tool .....	112
Spring, Inside .....	80
Inside .....	80
Outside .....	80
<b>Draft Tube</b> .....	<b>38</b>
<b>Drain Plug, Oil Pan</b> .....	<b>38</b>
<b>Driven Gear, Speedometer</b> .....	<b>63</b>
<b>Driven Gear, Tachometer</b> .....	<b>64</b>
<b>Drop Curtain</b> .....	<b>9</b>
<b>Drums, Brake</b> .....	<b>23</b>
<b>Dynamat</b> .....	<b>119</b>

## E

<b>Elbow</b> .....	<b>75</b>
<b>Emblem, Glovebox</b> .....	<b>83</b>
<b>Emblems &amp; Bezels, Roof</b> .....	<b>83</b>
<b>Emblems &amp; Mouldings</b> .....	<b>82-83</b>
<b>Emergency Brake Parts</b> .....	<b>27</b>
Brake Shoe "C"-clip .....	27
Cable .....	27
Cable Clip .....	27
Cable Pulley .....	27
Equalizer Lever Nut .....	27
Equalizer Rod .....	27
Link Spring .....	27
Ratchet .....	27
Ratchet Spring .....	27
Release Handle .....	27
<b>End Cup, Tie Rod</b> .....	<b>28</b>
<b>Engine</b> .....	<b>36-38</b>
Block Vent Cover .....	37
Compartment & Re-conditioning Paint .....	118
Gaskets .....	39
Mounts, Front .....	41
Rebuilding Books .....	108
Reconditioning Items .....	116-117
Steady Rest Kit .....	41

### Equalizer

Lever Nut, Emergency Brake .....	27
Rod, Emergency Brake .....	27
Shaft Parts .....	42

### Exhaust

Deflector .....	40
Heat Riser Valves .....	40
Manifold Gasket Sets .....	39
Manifolds .....	40
Valve .....	36

### Extension

Housing Bushing .....	42-43
Housing Seal .....	42-43

## F

<b>Face Plate, Tachometer</b> .....	<b>64</b>
<b>Fan Belts</b> .....	<b>45</b>
<b>Fan Shroud</b> .....	<b>44</b>
<b>Fenders</b> .....	<b>84</b>
Gripper .....	115
Nameplates .....	82
Ornaments .....	82
Skirt Bracket Set .....	87
Skirt Moulding .....	83
Skirt Seals .....	87
Skirt Stone Guards .....	83
Skirts .....	87
Splash Shields .....	84
<b>Filler Cap &amp; Gasket, Master Cylinder</b> .....	<b>25</b>
<b>Filler Door Hinges, Gas Tank</b> .....	<b>47</b>
<b>Filler, Breather Cap, Oil</b> .....	<b>38</b>
<b>Filter</b>	
Air .....	40
Power Steering Pump .....	30
Strainer & Gasket, Fuel .....	40
<b>Firewall Cover &amp; Clips</b> .....	<b>68</b>
<b>Firewall Grommet Set</b> .....	<b>68</b>
<b>"Flame Thrower"</b> .....	<b>54</b>
<b>Flange Gasket, Rear Axle</b> .....	<b>33</b>
<b>Flasher, Turn Signal</b> .....	<b>64</b>
<b>Flex Hose, Power Brake Booster</b> .....	<b>26</b>
<b>Flex Plate</b> .....	<b>37</b>
<b>Floor Cover, Vinyl</b> .....	<b>9</b>
<b>Floor Panels</b> .....	<b>85</b>





Floormats	7
Flywheel Parts	37
Housing Seal	37
Ring Gear	37
Ford Decals	101
Ford Road Series Books	109
Ford-O-Matic Parts	43
Frame	41
Front Coil Springs	34
Front Engine Mounts	41
Front Suspension	32
Fuel Parts	46-49
Filter	40
Bowl to Fuel Pump Gasket	47
Bracket	47
Gasket	47
Line Hose	47
Line Kits	47
Pump	47
Pump Mounting Gasket	47
Pump to Carburetor Fuel Line	47
Stabilizer	115
Strainer	47
Fuses	61

## G

Garnish Rail Mouldings, Rear	83
Gas	
Caps	46
Door Emblems	17 & 83
Sending Unit Floats	46
Tank & Parts	46
Tank Filler Door Hinges, Springs & Bumpers	47
Tank Slushing Compound	117
Gas Pumps (Novelty)	125
Gasket	
Brake Line	25
Seal Kit, Transmission	42
Water Bypass Tube	45
Water Pump to Block	45
Gauge Lens, Dash	62
Gear Pin, Distributor	55
Gearbox Parts, Steering	29
Gearshift Lever Boot, Manual Transmission	42
General Information Books	111
Generator Parts	50
Belt Adjustment Arm	50
Mounting Bracket	50
Overhaul Kit	50
Rebuild Kit	50
Support Bracket	50
to Regulator Wiring	60
Glass	69
Door	69
Porthole	69
Windwing	69
Glass Fuses	61
Glasswork Items	117
Glovebox Parts	65
Door Arm	65
Emblem	65
Finish Panel	65
Grommets & Bumpers	65
Latch Guide Plate	65
Liner	65
Lock Push Button Bezel	65
Striker	65

Grease	116
Baffle Gasket, Front Brake	23
Seal, Front	23
Seal, Rear Axle	23
Grease Packer	119
Grille	67
Hood Scoop	67
Mouldings	67 & 82
Panel Nameplate, Upper	67 & 82
Panel Ornaments, Upper	67
Ground Strap	52

## H

Handle Shaft Assembly, Door	80
Hard Top	
Alignment Dowel	15
Headliners	14
Headliner Bows	14
Headliner Bow Guide Clip	14
Headliner Ends & Corners	14
Tack Strip	15
Trim Clip	15
Hardware, Parking Light	56
Hat Pins	124-125
Headlight Parts	56
Bucket Spring	56
Bucket to Fender Gasket	56
Bulb Pigtail	56
Crossover wire	60
Dimmer Switch	64
Door Lower Retainer Clip	56
Door Trim	82
Retaining Ring	56
Switch	64
Wiring	60
Headliners	14
Bow Sets	14
Heat	
Control Tube, Automatic Choke	49
Riser Valves, Exhaust	40
Shield, Battery	52
Heater	74-75
Air Duct Clamp	75
Blower Motor	74
Blower Motor Switch	65
Blower Motor to Housing Grommet	74
Case Gaskets	74
Control Bezel & Face Plate	74
Control Cable	74
Control Knobs	65
Control Lever	74
Core	74
Door Knob	74
Hose & Clamp	75
Motor Fan	74
Motor Switch	74
Plenum Chamber	74
Seal	74
Wiring	60-61
Hinge Spring, Hood	67
Hold-Down	
Bolt, Battery	51
Clamp, Battery	51
Clamps, Distributor	55
Kit, Brake Shoe	24
to Inner Fender Panel Bracket, Battery	51
Hood Light	112
Hood Parts	67
Bumper Set	67

Hinge Brackers	67
Hinge Spring	67
Latch Parts	67
Release Cable, Bracket & Clamp	67
Scoop Block-off Plate Kit	67
Scoop Grille	67
to Cowl Seal	67
Horn	66
Ring Kits	66
Wiring	60
Horseshoe Lock & Washer, Brake	24
Hose	
Brake	25
Clamps, Band-type	44
Heater	75
Kits, Power Steering	31
Radiator	44
Retainer Clip, Brake	25
Hub Caps	21
Hub Grease Cap & Tool	23

## I

Identification Books	106
Idler Arm	28
Bushing	28
Ignition Coil	54
Mounting Strap	54
Resistor	54
to Distributor Wiring	60
Wire	61
Ignition Parts	54
Switch	64
Switch Bezel Retainer Nut	64
Ignitor	54
Inner Tie Rod	28
Instrument Cluster Lens Seal Kit	62
Instrument Jumper Wire	61
Insulation	7
Intake	
Manifold Gasket Sets	39
Valve	36
Valve Seat	36
Interior Trim	2-10

## J

Jack Strap	17
Jacking Plates	73
Joints, Ball	32
Junction Block, Wiring	60

## K

Key Blanks	112
Key Fob	112
Kick Panel Retainer	8
Kick Panels	8
Kick down Spring, Throttle Knob	49
Cowl Vent	68
Heater Control	65
Radio	20

## L

Latch Parts	
Hood	67
Springs, Door	79
Leaf Springs	35
Center Pad & Retainer, Rear	35
Liner	35



- Anti-Squeak Pads ..... 35
- U-bolt, Rear ..... 35
- Lens Gasket, Parking Light** ..... 56
- Lens Retainer, Parking Light** ..... 56
- Lever Oil Seal, Automatic Transmission** 43
- Lever, Turn Signal** ..... 64
- License Plate**
  - Bracket, Front ..... 58
  - Frames ..... 113
  - Light Assembly, Rear ..... 59
  - Light Wiring ..... 60
  - Parts ..... 58-59
  - Reflector Bolts ..... 119
- Lift Channels** ..... 77
- Lifter, Valve** ..... 36
- Light**
  - Bucket, Tail ..... 57
  - Bulbs ..... 59
  - Gasket Kits ..... 59
- Light Housing**
  - Map ..... 56
  - Parking ..... 56
  - Reflector, Back-up ..... 58
  - to Body Gasket & Blank-off Plate Pad, Back-up ..... 58
  - to Body Pad, Tail ..... 57
- Light Lens**
  - Back-up ..... 58
  - Bezel, Tail ..... 57
  - Map ..... 56
  - Parking ..... 56
  - Tail ..... 57
  - to Housing Gasket, Back-up ..... 58
  - to Housing Gasket, Tail ..... 57
- Light Socket & Pigtail, Back-up** ..... 58
- Light Socket, Tail** ..... 57
- Light Switch**
  - Back-up ..... 42
  - Brake ..... 65
  - Courtesy ..... 65
- Light, Hood** ..... 112
- Lighter, Cigar** ..... 65
- Lights** ..... 56-59
- Liner, Glovebox** ..... 65
- Link Rod Bolt, Master Cylinder** ..... 25
- Link Spring, Emergency Brake** ..... 27
- Lock & Ignition Cylinder Set, Door** ..... 79
- Lock Button**
  - Door ..... 79 & 121
  - Grommet, Door ..... 79
  - Rod, Door ..... 79
- Lock Cylinder**
  - Door ..... 79
  - Lever & Spring, Door ..... 79
  - Retainers, Door ..... 79
- Lock Striker Plate & Parts, Door** ..... 79
- Lock, Automatic Transmission** ..... 112
- Lower Retainer Strip, Door Glass** ..... 77
- Lug Nuts** ..... 23

## M

- Magnetic Signs** ..... 113
- Main Bearings** ..... 36
- Manual Seat Parts** ..... 4
  - Adjuster Handle ..... 4
  - Adjustment Lever Shield ..... 4
  - Track Assist Spring ..... 4
  - Track Cable ..... 4
- Manual Transmission Gasket Set** ..... 42

- Manual Window Regulator** ..... 81
- Manuals** ..... 104-106
  - Owner's ..... 105
  - Shop ..... 104
  - Wiring Diagram ..... 105
- Map Light Housing** ..... 56
- Map Light Lens** ..... 56
- Master Cylinder Parts** ..... 25
  - Drip Tray ..... 25
  - Filler Cap & Gasket ..... 25
  - Link Rod Bolt ..... 25
  - Outlet Fitting ..... 25
  - Outlet Fitting Bolt ..... 25
  - Pushrod Bushing ..... 25
  - Rebuild Kit ..... 25
- Mat, Trunk** ..... 16
- Mirrors** ..... 72
- Motor Gear Repair Kit, Power Window** .. 81
- Motor Mounts** ..... 41
- Moulding, Rear Window** ..... 83
- Mounting Parts**
  - Body to Frame ..... 41
  - Bracket, Generator ..... 50
  - Brackets, Power Brake Booster ..... 26
  - Strap, Ignition Coil ..... 54
- Mufflers, Smithy** ..... 40

## N

- Nameplate & Emblem, Dash** ..... 62 & 83
- Nameplate, Quarter Panel** ..... 83
- Needle, Tachometer** ..... 64
- Neutral Safety Switch** ..... 42 & 64
- Neutral Safety Switch Wire** ..... 61
- Non-ford Books** ..... 110
- Nose Panel** ..... 84
- Nostalgia Decals** ..... 101-102
- Novelties** ..... 122-123

## O

- Oil** ..... 116
  - Filters ..... 40
  - Pump & Parts ..... 38
  - Dipstick ..... 38
  - Draft Tube ..... 38
  - Filler, Breather Cap ..... 38
  - Filter Canister Parts ..... 40
  - Pan Drain Plug ..... 38
  - Pressure Sending Unit ..... 38
- Outer Tie Rod** ..... 28
- Outlet Fitting Bolt, Master Cylinder** ..... 25
- Outlet Fitting, Master Cylinder** ..... 25
- Overdrive**
  - Cable & Handle ..... 47
  - Governor Cover ..... 42
  - Housing Bushing ..... 42
  - Housing Seal ..... 42
  - Kickdown Switch ..... 42
  - Solenoid Seal ..... 42
  - Wire ..... 60
- Overflow Tube, Radiator** ..... 44
- Overhaul Kits**
  - Brake ..... 23
  - Transmission ..... 43
- Owner's Manuals** ..... 105

## P

- Pad Retainer Strip Set, Dash** ..... 62
- Paint Books** ..... 107
- Paint, Engine** ..... 118
- Panel Retainer, Kick** ..... 8
- Panels, Kick** ..... 8
- Parking Light & Turn Signal Wiring** ..... 60
- Parking Light Parts** ..... 56
  - Body to Fender Pad ..... 56
  - Hardware ..... 56
  - Housing ..... 56
  - Lens ..... 56
  - Lens Gasket ..... 56
  - Lens Retainer ..... 56
  - Socket & Wire ..... 56
- Pawl Spring, Turn Signal Switch** ..... 64
- Pedal**
  - Accelerator & Rod ..... 49
  - Bushing to Spring Insulator, Brake ..... 24
  - Pads, Brake ..... 24
- Pedal Cars** ..... 126-127
- Performance Books** ..... 108
- Pertronix** ..... 54
- Petcock, Radiator** ..... 44
- Pillar Chrome & Bracket, Door** ..... 79
- Pilot Bearing, Clutch** ..... 42
- Pinion**
  - Bearing Retainer "O" ring, Rear Axle ... 33
  - Bearing Spacer ..... 33
  - Oil Seal, Rear Axle ..... 33
  - Pilot Bearing, Rear Axle ..... 33
  - Pilot Bearing Retainer, Rear Axle ..... 33
- Piston Rings** ..... 36
- Pistons** ..... 36
- Pivot Shaft Washer** ..... 70
- Plate**
  - Frames, License ..... 113
  - Gaskets, Rear Deck ..... 13, 15
  - Pawl, Turn Signal Switch ..... 64
  - Retainer Spring, Turn Signal Switch ... 64
- Plenum Chamber, Heater** ..... 74
- Plugs, Spark** ..... 54
- Point Sets, Distributor** ..... 55
- Points & Condenser Replacement** ..... 54
- Polishes** ..... 118
- POR-15 Products** ..... 120-121
- Porthole**
  - Glass ..... 69
  - Glass Seal ..... 69
  - Installation Kit ..... 69
  - Rings ..... 69
- Power Brake Boosters & Parts** ..... 26
- Power Cylinders** ..... 30
  - Mounting Bushings ..... 30
- Power Seat Parts** ..... 4
  - Regulator Supports ..... 4
  - Relays ..... 4
  - Stop Plates ..... 4
  - Switch Parts ..... 4
  - Worm Gear ..... 4
- Power Seat Wiring** ..... 61
- Power Steering**
  - Belt ..... 45
  - Control Valves & Parts ..... 31
  - Hose Insulator ..... 31
  - Hose Kits ..... 31
  - Pump Parts ..... 30-31
- Power Window** ..... 81
  - Motor Gear Repair Kit ..... 81



Regulator to Drive Assembly Coupling	81
Switch	81
Switch Backing Plate	81
Wiring	61
<b>PowerGen</b>	<b>50</b>
<b>Pressure Plate, Clutch</b>	<b>42</b>
<b>Pulley to Fan Spacer, Water Pump Pump</b>	<b>45</b>
Rebuild Kit, Water	43
to Control Valve Pressure Line,	
Power Steering	31
Water	45
<b>Pushrod</b>	<b>37</b>
<b>Pushrod Bushing, Master Cylinder</b>	<b>25</b>

## Q

<b>Quarter Panel</b>	
Cardboard	10
Nameplate	83
Sheetmetal	86

## R

<b>Radiator Parts</b>	<b>44</b>
Cap	44
Hoses	44
Overflow Tube	44
<b>Radio</b>	<b>18-20</b>
Antenna	20
Knobs	20
Speakers	19
<b>Rail Vinyl Sets, Door Garnish</b>	<b>9</b>
<b>Ratchet Spring, Emergency Brake</b>	<b>27</b>
<b>Rear Axle Parts</b>	<b>33</b>
Bumper	33
Cover Gasket	33
Flange Gasket	33
Grease Seal	33
Pinion Bearing Retainer "O"-ring	33
Pinion Bearing Set	33
<b>Rear Clamp Lever</b>	<b>12, 15</b>
<b>Rear Clamp Stud</b>	<b>13, 15</b>
<b>Rear Deck Plate Gaskets</b>	<b>13, 15</b>
<b>Rear Wheel Bearing</b>	<b>33</b>
<b>Rear-View Mirror</b>	
Base Gasket, Outside	72
Inside	72
Outside	72
<b>Rebuild Kit, Master Cylinder</b>	<b>25</b>
<b>Regulator to Drive Assembly Coupling, Power Window</b>	<b>81</b>
<b>Regulator, Voltage</b>	<b>15</b>
<b>Release Cable, Bracket &amp; Clamp, Hood</b>	<b>67</b>
<b>Release Handle, Emergency Brake</b>	<b>27</b>
<b>Remote Control Spring, Inside Door Handle</b>	<b>80</b>
<b>Resistor, Ignition Coil</b>	<b>54</b>
<b>Restoration</b>	
Books	107-108
Supplies	118-119
<b>Retainer Clip</b>	
Brake Hose	25
Headlight Door	56
<b>Retaining</b>	
Nut, Dash	63
Ring, Headlight	56
<b>Return Springs, Brake Shoe</b>	<b>24</b>
<b>Ring &amp; Pinion, Differential</b>	<b>33</b>
<b>Rings, Piston</b>	<b>36</b>

<b>Rocker</b>	
Arm	37
Arm Shaft	37
Panels	84
<b>Rod Bearings, Connecting</b>	<b>36</b>
<b>Roller Assembly, Window</b>	<b>81</b>
<b>Roof Emblems &amp; Bezels</b>	<b>83</b>
<b>Rotor, Distributor</b>	<b>55</b>

## S

<b>Safety Switch, Neutral</b>	<b>42 &amp; 64</b>
<b>Sales Brochures</b>	<b>105</b>
<b>Scoop Block-off Plate Kit, Hood</b>	<b>67</b>
<b>Scoop Grille, Hood</b>	<b>67 &amp; 82</b>
<b>Scout-a-longs</b>	<b>125</b>
<b>Scuff Plates</b>	<b>79</b>
<b>Seal Puller</b>	<b>119</b>
<b>Seals</b>	<b>76-78</b>
A-pillar	76
Accelerator Rod to Floor	49
Cowl	76
Defroster Nozzle	75
Door	77
Fender Skirt	87
Front of Door	77
Heater	74
Inner Dog Leg	77
Retainers, Door	77
Rear Stone Deflector to Bumper	73
Steering Column Floor	29
Valve Stem	37
<b>Sealed Beam Headlights</b>	<b>56</b>
<b>Seat</b>	
Adjuster Handle, Manual	4
Adjustment Lever Shield, Manual	4
Backrest Panel	3
Covers	2-3
Foam Sets	3
Track Assist Spring, Manual	4
Track Cable, Manual	4
Wiring	61
<b>Seat Belts</b>	<b>5</b>
<b>Secondary Vacuum Diaphragm, Carburetor</b>	<b>48</b>
<b>Sector Shaft Bushing, Steering Gearbox</b>	<b>29</b>
<b>Self-adjuster Assembly, Brake Shoe</b>	<b>24</b>
<b>Sending Unit</b>	
Floats, Gas Tank	46
Gas Tank	46
"O" ring & Lock Ring, Gas Tank	46
Oil Pressure	38
Water Temperature & Adapter	45
<b>Shackle Kit &amp; Bushings, Rear</b>	<b>35</b>
<b>Shaft &amp; Bushing Kits, Control Arm</b>	<b>32</b>
<b>Shaft Seal, Distributor</b>	<b>55</b>
<b>Sheetmetal &amp; Welding Books</b>	<b>107</b>
<b>Sheetmetal</b>	<b>84-87</b>
<b>Shift Knobs</b>	<b>43 &amp; 120</b>
<b>Shirts, Tee</b>	<b>128-129</b>
<b>Shock Absorber</b>	<b>34</b>
Spring, Rear	35
<b>Shop Manuals</b>	<b>104</b>
<b>Show Supplies</b>	<b>113</b>
<b>Side Vent</b>	
Door Spring, Cowl	68
Screen, Cowl	68
<b>Side Ventilator</b>	
Grille, Cowl	68
Hinge Assembly, Cowl	68

<b>Signs, Magnetic</b>	<b>113</b>
<b>Sleeve &amp; Spacer Kit, Bumper Guard</b>	<b>73</b>
<b>Sleeve, Cylinder</b>	<b>36</b>
<b>Slushing Compound, Gas Tank</b>	<b>117</b>
<b>Smithy Mufflers</b>	<b>40</b>
Decal	40
<b>Sound Deadener</b>	<b>119</b>
<b>Spacer, Water Pump</b>	<b>45</b>
<b>Spare Wheel</b>	
Clamp	17
Hold Down Brackets	17
"J"-Hook	17
Mounting Plate	17
Nut	17
<b>Spark Plugs</b>	<b>54</b>
<b>Spark Plug Wire</b>	
Grommets & Brackets	54
Set	54
Shield	54
<b>Speedometer</b>	<b>63</b>
Cable	63
Dome	63
Driven Gear	63
Face Dial	63
<b>Splash Shields, Fender</b>	<b>84</b>
<b>Spotlight</b>	<b>112</b>
<b>Springs &amp; Shocks</b>	<b>34-35</b>
<b>Springs, Gas Tank Door</b>	<b>47</b>
<b>Stabilizer Bar</b>	
Bushings	32
End Repair Kit	32
<b>Starter</b>	
Cable Bracket	52
Cable Grommet	52
Cables	52
Drive	53
Motor	53
Parts	53
Relay	53
to Flywheel Housing Seal	37
<b>Stealth Speakers</b>	<b>19</b>
<b>Steering</b>	
Belt, Power	45
Column Bracket Cover Insulator	29
Column Floor Seal	29
Column to Dash Grommet	29
Gasket	29
Gearbox Parts	29
Sector Shaft Bushing & Seal	29
Worm Gear Lower Race	29
Wheels	29
<b>Stereo Speakers</b>	<b>19</b>
<b>Stone</b>	
Deflector to Bumper Seal, Rear	73
Guards, Fender Skirt	87
<b>Storage Items</b>	<b>115</b>
<b>Straps &amp; Hardware, Gas Tank</b>	<b>46</b>
<b>Strip Caulk</b>	<b>117</b>
<b>Stud, Rear Clamp</b>	<b>13, 15</b>
<b>Sun Visors Parts</b>	<b>8</b>
Anchor Pin	8
Brackets & Rods	8
Clip	8
<b>Support Bracket, Generator</b>	<b>50</b>
<b>Swing Arm Bar &amp; Parts</b>	<b>12</b>
<b>Switches</b>	<b>64-65</b>
Backing Plate, Power Window	81
Brake Light	24 & 65
Power Window	81





## T

- Tachometer Parts** ..... 64
  - Cable & Housing ..... 64
  - Driven Gear ..... 64
  - Face Plate ..... 64
  - Needle ..... 64
- Tags & Decals** ..... 96-102
- Tail Light Parts** ..... 57
  - Bucket ..... 57
  - Hardware ..... 57
  - Housing to Body Pad ..... 57
  - Lens ..... 57
  - Lens Bezel ..... 57
  - Lens to Housing Gasket ..... 57
  - Socket ..... 57
- Tee-shirts** ..... 128-129
- Temperature Gauges** ..... 63
- Tender, Battery** ..... 115
- Thermostat** ..... 45
  - Housing & Gasket ..... 45
- Throttle Rod, Primary** ..... 48
- Throttle Return** ..... 49
- Throwout Bearing & Hub** ..... 42
- Thunderbird Specialty Books** ..... 103
- Tie Rod**
  - Connecting Sleeve ..... 28
  - End Cup ..... 28
  - Inner & Outer ..... 28
- Timing Chains** ..... 37
- Timing Pointer** ..... 37
- Tires** ..... 28
- Tonneau Cover Kits** ..... 4
- Tools** ..... 112, 119
- Top Parts** ..... 11-15
  - Clamp ..... 12-13
  - Cup ..... 12
  - Gasket to Air Cleaner, Carburetor ..... 49
  - Moulding, Convertible ..... 82
  - Rear Fastener, Hard & Soft ..... 13, 15
- Track Cable** ..... 5
- Transmission** ..... 42-43
  - Gasket Set, Manual ..... 42
  - Mounts ..... 41
  - Rebuilding Books ..... 108
- Tray, Battery** ..... 51
- Trim**
  - Dash ..... 62
  - Kits, Dash ..... 62
  - Panels, Door ..... 10
- Trunk** ..... 16-17
  - Divider Board ..... 16
  - Hinge Spring ..... 17
  - Jack Strap ..... 17
  - Lid Bumpers ..... 17
  - Lid Emblem ..... 82
  - Lid Handle ..... 16
  - Lid Weatherstrip ..... 16
  - Lock Cylinder & Keys ..... 16
  - Lock Keyhole Cover ..... 16
  - Lock Release Rod ..... 16
  - Lock Sleeve Pad ..... 16
  - Mat ..... 16
  - Metal ..... 87
  - Side Boards ..... 16
- Tune-up Kits**
  - Carburetor ..... 48
  - Distributor ..... 55
- Turn Signal Parts** ..... 64
  - Canceling Plate ..... 64

- Flasher ..... 64
- Lever ..... 64
- Switch Canceling Cam ..... 64
- Switch Pawl Spring ..... 64
- Switch Plate Pawl ..... 64
- Switch Plate Retainer Spring ..... 64
- Switch Wire ..... 61

## U

- Universal Joint** ..... 33
- Upholstery Books** ..... 107

## V

- Vacuum Advance, Distributor** ..... 55
- Vacuum Line & Hose, Power Brake**
  - Booster** ..... 26
- Valve**
  - Guide ..... 37
  - Intake & Exhaust ..... 36
  - Keeper ..... 36
  - Lifter ..... 36
  - Spring ..... 37
  - Spring Insert Shim ..... 37
  - Stem Caps ..... 121
  - Stem Seals ..... 37

- Vent**
  - Control Assembly ..... 75
  - Door Spring, Cowl Side ..... 68
  - Knob, Cowl ..... 68
  - Screen, Cowl Side ..... 68
- Ventilator**
  - Air Damper Seal ..... 75
  - Air Duct ..... 75
  - Air Duct Assembly ..... 75
  - Air Duct Scoop ..... 75
  - Air Valve Gasket ..... 75
  - Cable Brackets ..... 75
  - Grille, Cowl Side ..... 68
  - Hinge Assembly, Cowl Side ..... 68
  - Register ..... 75
  - System Parts ..... 75

- Vinyl Floor Cover** ..... 9
- Visor, Sun** ..... 8
  - Anchor Pin ..... 8
  - Brackets & Rods ..... 8
  - Clip ..... 8
- Voltage Reducers** ..... 52
- Voltage Regulator** ..... 51

## W

- Washer**
  - Bag ..... 71
  - Fluid Jets ..... 71
  - Fluid Pump ..... 71
  - Fluid Seals ..... 71
  - Hose ..... 70
  - Hose Tee ..... 71
  - Pedal & Pad ..... 71

- Water**
  - Blade™ ..... 113
  - Bypass Tube Gasket ..... 45
  - Pump ..... 45
  - Temperature Sending Unit & Adapter ..... 45
- Weatherstripping** ..... 76-78
- Wedge Spacer** ..... 10

- Wheel**
  - Bearing Sets ..... 23
  - Bearing, Rear ..... 33

- Cylinder Rebuild Kits ..... 26
- Cover ..... 21
- Cover Clip ..... 21
- Cover Medallion ..... 21
- Cover Tool ..... 17
- Cylinder Bleeder Screw ..... 26
- Cylinder, Front Brake ..... 26
- Cylinder, Rear Brake ..... 26
- Dollies ..... 115
- Studs ..... 23

## Whitewall Tires

- Windlace**
  - Cloth ..... 8
  - Vinyl ..... 8

- Window**
  - Crank ..... 80
  - Mouldings, Rear ..... 83
  - Regulator, Manual ..... 81
  - Roller Assembly ..... 81

- Windshield**
  - Moulding Joint Cover ..... 82
  - Seal ..... 76
  - Washer ..... 71
  - Wiper ..... 70

- Windwing** ..... 69
  - Assembly ..... 69
  - Glass ..... 69
  - Glass Retainer Strip ..... 69
  - Hinge & Bushing ..... 69

- Wiper** ..... 70-71
  - Arm ..... 70
  - Arm to Motor Grommet ..... 70
  - Control Knob ..... 70
  - Motor Conversion Kit ..... 70
  - Pivot Bezels ..... 70
  - Pivot Shaft Nut ..... 71
  - Retainer Plate & Spring ..... 70

## Wire Grommets & Brackets, Spark

- Plug** ..... 54

## Wire Shield, Spark Plug

- ..... 54

## Wire Wheel Covers

- ..... 21

## Wiring

- Back-up Light ..... 61
- Bulk ..... 60
- Diagram Manuals ..... 105
- Dome Light ..... 60
- Generator to Regulator ..... 60
- Harnesses ..... 60
- Harness Straps ..... 61
- Headlight ..... 60
- Heater ..... 60
- Heater Blower Motor ..... 61
- Horn ..... 60
- Ignition Coil to Distributor ..... 61
- License Plate Light ..... 60
- Oil Pressure Sending Unit ..... 60
- Overdrive ..... 60
- Parking Light ..... 60
- Power Seat ..... 61
- Power Window ..... 61
- Turn Signal ..... 61

## Worm Gear, Power Seat

- ..... 4

## Worm Roller Bearing, Steering Gearbox

- ..... 29

716-210-1340 ..... Local & Foreign  
 800-777-0948 ..... USA & Canada  
 716-210-1370 ..... Fax  
 E-MAIL ..... customerservice@macsauto.com  
 WEBSITE ..... www.macsautoparts.com

# Our New Building!

We're proud to unveil our newly completed state-of-the-art facility! It's 50,000 square feet of heaven for anyone who truly lives vintage Ford cars & trucks—from Model T's & Model A's to Mustang's & Mercury's.

Visitors will love our huge new showroom, with an abundance of Ford parts & accessories as well as 4 of our own antique & classic cars. Customers will benefit from being able to look a part over closely before making a purchase. They'll also enjoy the rare old Ford items from MAC's extensive private collection.

Our all new, state-of-the-art warehousing system is designed to verify that parts are in stock & easy to pull for prompt filling of orders. This ensures that our customers will receive their orders faster & more accurately than ever before. Our shipping department now has the capacity to ship over 500 packages a day!

What does this mean to you? Greater product availability & faster shipping. Add to this the same great prices & customer service that MAC's is known for & we're sure to be on the top of your list for Ford Antique & Classic parts.



RANDY & RICK UNPACKING



THE NEW SHOWROOM

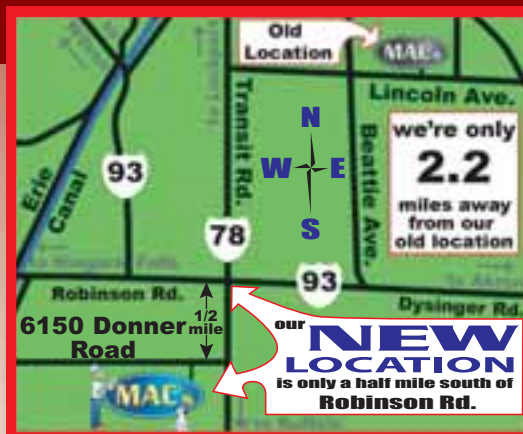

Stop by our new location, just a few minutes Northeast of Buffalo & Niagara Falls, NY.



MAC's Antique Auto Parts  
6150 Donner Road  
Lockport, NY 14094  
800-777-0948  
[www.macsautoparts.com](http://www.macsautoparts.com)

Visit our website: [www.macsautoparts.com](http://www.macsautoparts.com) to see our move step-by-step & to browse or order parts.



# MACcessories

## Novelties



## Decals



## Books

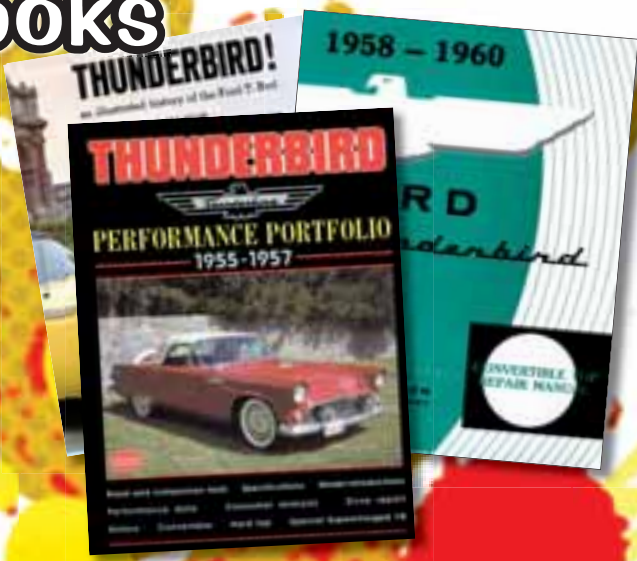

## Restoration Supplies







We now offer these decal kits for two main reasons. The first reason & probably the most important one to you, is to save you money! The second reason is to make it quick & easy for you to order the proper decals for your engine compartment.

These kits come with all the decals in one package. All you need to know is the year of your T-Bird. They are reproductions of the factory stampings, correct down to the smallest detail.

**1955 Decal Kit Contains 1 each of the Following Decals:**

- |                                         |                                  |
|-----------------------------------------|----------------------------------|
| Air cleaner service instructions - DF86 | Jacking instruction decal - DF40 |
| Air scoop removal decal - DF89          | Oil filter canister decal - DF82 |
| Auto trans. glove box decal - DF81      | Paint OK decal set - DF235       |
| Folding top instruction decal - DF90    | Tire pressure decal - DF80       |
| Heater box decal - DF39                 | Voltage regulator decal - DF84   |



1955 Decal kit ..... DK35 17.95 kit

**1956 Decal Kit Contains 1 each of the Following Decals:**

- |                                         |                                  |
|-----------------------------------------|----------------------------------|
| Air cleaner service instructions - DF86 | Jacking instruction decal - DF40 |
| Air scoop removal decal - DF89          | Oil filter canister decal - DF82 |
| Auto trans. glove box decal - DF81      | Paint OK decal set - DF236       |
| Folding top instruction decal - DF90    | Starter decal - DF131            |
| Heater box decal - DF39                 | Tire pressure decal - DF80       |
| Ignition coil decal - DF33              | Voltage regulator decal - DF32   |



1956 Decal kit ..... DK36 17.95 kit

**1957 Decal Kit Contains 1 each of the Following Decals:**

- |                                      |                                |
|--------------------------------------|--------------------------------|
| Air cleaner service decal - DF83     | Heater box decal - DF39        |
| Air scoop removal decal - DF89       | Ignition coil decal - DF33     |
| Auto trans. glove box decal - DF81   | Jack instruction decal - DF41  |
| Body door decal - DF93               | Paint OK decal set - DF237     |
| Folding top instruction decal - DF90 | Starter decal - DF131          |
| Generator "B" decal - DF68           | Voltage regulator decal - DF32 |



1957 Decal kit ..... DK37 17.95 kit

# HUGE Savings

**1961 Decal Kit Contains 1 each of the Following Decals:**

- |                                         |                               |
|-----------------------------------------|-------------------------------|
| Ignition coil - DF33                    | FoMoCo antifreeze tag - DF120 |
| Air cleaner, 390 CID - DF54             | Oil filler cap - DF164        |
| Air cleaner, service instruction - DF83 | BATTERY TEST OK - DF405       |
| Voltage regulator - DF107               | Jack instruction - DF513      |
| CAUTION FAN - DF118                     | A/C compressor - DF574        |
| Voltage regulator warning, pair - DF347 |                               |



1961 Decal kit ..... DK41 17.95 kit

**1962 Decal Kit Contains 1 each of the Following Decals:**

- |                                         |                                            |
|-----------------------------------------|--------------------------------------------|
| Ignition coil - DF33                    | Tire pressure - DF369                      |
| Air cleaner, 390 CID - DF54             | BATTERY TEST OK - DF405                    |
| Air cleaner, service instruction - DF83 | Starter - DF447                            |
| CAUTION FAN - DF118                     | Generator - DF515                          |
| FoMoCo antifreeze tag - DF120           | Fuel filter - DF1037                       |
| Jack instruction - DF132                | Air cleaner, Autolite Spark Plugs - DF160  |
| Oil filler cap - DF164                  | Air cleaner, crankcase ventilation - DF350 |
| Voltage regulator - DF337               |                                            |



1962 Decal kit ..... DK42 17.95 kit



**1963 Decal Kit Contains 1 each of the Following Decals:**

- |                                            |                            |
|--------------------------------------------|----------------------------|
| Air cleaner, 390 CID - DF54                | Jack instruction - DF219   |
| Air cleaner, service instruction - DF83    | Tire pressure - DF369      |
| CAUTION FAN - DF118                        | BATTERY TEST OK - DF405    |
| FoMoCo antifreeze tag - DF120              | Starter - DF447            |
| Air cleaner, Autolite Spark Plugs - DF160  | Ignition coil - DF518      |
| Oil filler cap - DF164                     | Fuel filter - DF1037       |
| Battery CAUTION - DF198                    | Voltage regulator - DF1038 |
| Air cleaner, crankcase ventilation - DF350 |                            |



1963 Decal kit ..... DK43 17.95 kit

**1964 Decal Kit Contains 1 each of the Following Decals:**

- |                                           |                                            |
|-------------------------------------------|--------------------------------------------|
| Air cleaner, 390 CID - DF54               | Ignition coil - DF224                      |
| CAUTION FAN - DF118                       | Jack instruction - DF249                   |
| Air cleaner, service instruction - DF149  | Fuel filter - DF280                        |
| Air cleaner, front - DF150                | Service specification - DF345              |
| Oil filler cap - DF164                    | Air cleaner, crankcase ventilation - DF350 |
| Battery Test OK - DF194                   | Voltage regulator - DF412                  |
| Battery CAUTION - DF198                   | Starter - DF447                            |
| Air cleaner, Autolite Spark Plugs - DF160 | Rotunda antifreeze tag - DF699             |



1964 Decal kit ..... DK44 17.95 kit

**1965 Decal Kit Contains 1 each of the Following Decals:**

- |                                           |                                     |
|-------------------------------------------|-------------------------------------|
| Service specification - DF20              | Rotunda antifreeze tag - DF699      |
| Air cleaner, 390 CID - DF54               | Master cylinder warning tag - DF729 |
| CAUTION FAN - DF118                       | Fuel filter - DF280                 |
| Oil filler cap - DF164                    | Jack Instruction - DF290            |
| Battery Test OK - DF194                   | Voltage regulator - DF412           |
| Ignition coil - DF224                     | Starter - DF447                     |
| Air cleaner, Autolite Spark Plugs - DF352 | Power box - DF512                   |



1965 Decal kit ..... DK45 17.95 kit

**1966 Decal Kit Contains 1 each of the Following Decals:**

- |                                           |                             |
|-------------------------------------------|-----------------------------|
| Tire pressure, convertible only - DF293   | Air cleaner, 390 CID - DF54 |
| Tire pressure, hardtop only - DF294       | Air cleaner - DF115         |
| Disc brake master cylinder cap - DF331    | CAUTION FAN - DF118         |
| Air cleaner, Autolite Spark Plugs - DF352 | Oil filler cap - DF164      |
| Voltage regulator - DF412                 | Battery Test OK - DF194     |
| Power box - DF512                         | Ignition coil - DF224       |
| Rotunda antifreeze tag - DF699            | Jack instruction - DF238    |
| Service specification - DF20              | Fuel filter - DF280         |



1966 Decal kit ..... DK46 17.95 kit





## Engine Compartment Decals

### Air Cleaner



- 55-56 Service instructions . . . . . DF86 5.95
- 1957 Service instructions . . . . . DF83 2.95



- 55-57 Air scoop removal decal . . . . . DF89 3.95
- 1958 Thunderbird Interceptor air cleaner decal . . . . . DF430 5.95
- 1961 Service instructions . . . . . DF1226 4.95



- 58-63 Air cleaner service instructions decal with white background . . . . . DF83 2.95
- 61-64 Air cleaner crankcase ventilation decal . . . . . DF350 3.95
- 65-66 390 4-V premium fuel air cleaner decal . . . . . DF54 3.95



- 63-64 Air cleaner Autolite spark plug decal . . . . . DF160 3.95
- 1964 Air cleaner front decal . . . . . DF150 2.95
- 64-66 Air cleaner service instructions decal with gray background . . . . . DF149 2.95



- 65-66 Air cleaner Autolite spark plug decal . . . . . DF352 3.95
- 1966 428 4-V premium fuel air cleaner decal . . . . . DF221 3.95

### Valve Cover Decals



- 55-57 292 "THUNDERBIRD V-8" . . . . . DF72 8.95 pair
- 56-57 312 "THUNDERBIRD SPECIAL V-8" . . . . . DF71 8.95 pair

### Air Conditioning & Heater



- 58-60 Air conditioning evaporator case decal . . . . . DF1107 4.95
- 58-59 Air conditioning compressor charge decal . . . . . DF536 4.95
- 60-61 Air conditioning compressor decal . . . . . DF574 4.95



- 1961 Air conditioning compressor decal . . . . . DF1448 4.95
- 1963 Air conditioning aluminum tag decal . . . . . DF875 4.95
- 64-66 Air conditioning aluminum tag decal . . . . . DF876 4.95



- 64-66 Air conditioning dryer decal . . . . . DF550 2.95
- 55-57 Heater box decal . . . . . DF39 2.95

## Ignition Coil



- 56-57 Ignition coil decal . . . . . DF33 2.95
- 58-62 Coil decal . . . . . DF497 4.95



- 63-66 Coil decal, without transistorized ignition, FAC, see note below . . . . . DF224 4.95
- 64-66 Coil decal, with transistorized ignition, C3TF, see note below . . . . . DF1098 4.95

## Master Cylinder



- 1965 Disc brake master cylinder warning tag . . . . . DF729 3.95
- 1966 Disc brake master cylinder lid decal . . . . . DF331 2.95

## Generator

FHA C3TF B8A B9MF COMF & B8S are the Ford engineering numbers for the correct part. These numbers were ink-stamped on the part at the factory. If your original is missing or unreadable, select the most appropriate decal or tag from our listings.



- 56-62 Generator warning decal . . . . . DF1125 3.95



- 1956 Generator "B" decal . . . . . DF68 3.95
- 1957 Generator "C" decal . . . . . DF69 3.95



- 58-60 35 amp generator decal, with A/C, "B8A-10002-A" . . . . . DF1099 4.95
- 1959 35 amp generator decal, 352, with A/C, "B9MF-10002-A" . . . . . DF1102 4.95
- 59-60 30 amp generator decal, 352, without A/C, "FHA-10002-A" . . . . . DF448 4.95



- 59-60 35 amp generator decal, 430, with A/C, "COMF-10002-A" . . . . . DF406 4.95
- 59-60 30 amp generator decal, 430, without A/C, "B8S-10002-A" . . . . . DF1103 4.95

## Antifreeze



- 58-63 "FoMoCo" antifreeze tag . . . . . DF120 3.95
- 64-66 Rotunda antifreeze tag . . . . . DF699 4.95





Battery



- 62-63 Battery OK decal, decal has rounded corners . . . . . DF405 2.95
- 64-66 Battery test OK decal, decal has squared corners . . . . . DF194 2.95



- 62-71 Autolite Sta-Ful battery tag . . . . . DF784 4.95
- 63-64 Caution battery decal . . . . . DF198 3.95

Service Specification



- 1964 Service specifications decal . . . . . DF345 2.95
- 65-66 Service specifications decal . . . . . DF20 2.95

Fan



- 61-66 Caution fan decal . . . . . DF118 3.95

Oil



- 55-56 Oil filter canister decal . . . . . DF82 5.95
- 61-70 Autolite FL-1 oil filter decal with white background . . . . . DF684 4.95



- 61-66 Oil filler cap decal . . . . . DF164 2.95
- 65-70 Rotunda 6,000 mile oil filter decal with gold background . . . . . DF647 5.95

Starter



- 56-60 352 starter decal, "FAR-11001-A" . . . . . DF131 3.95
- 59-60 430 starter decal, "FAY-11002-A" . . . . . DF436 4.95
- 59-60 430 starter decal, "2900550" . . . . . DF1100 4.95



- 1961 Starter decal, "FAY-11002-A" . . . . . DF436 4.95
- 63-64 Starter decal, "C3SF-11001-A" . . . . . DF498 4.95
- 65-66 390 & 428 Starter decal, "C5AF-11001-A" . . . . . DF1097 4.95

Fuel Filter



- 62-63 **NEW** Fuel filter decal, for tri-power cars . . . . . DF1037 3.95
- 62-66 Fuel pump filter decal . . . . . DF280 2.95

Transistorized Ignition



- 64-66 Transistorized ignition cover decal . . . . . DF353 4.95
- 64-66 Transistorized ignition distributor decal . . . . . DF502 4.95

Voltage Regulator

FAC, C3TF, B8A, etc., are the Ford engineering numbers for the correct part. These numbers were ink-stamped on the part at the factory. If your original is missing or unreadable, we suggest you select the most appropriate decal or tag from our listing.



- 1955 Voltage regulator decal . . . . . DF84 3.95
- 56-57 Voltage regulator decal . . . . . DF32 3.95
- 58-61 Voltage regulator decal, 2900424, no AC . . . . . DF107 4.95



- 58-60 Voltage regulator decal, 29003, with AC, 35 amp 352, 430 . . . . . DF407 4.95
- 1960 Voltage regulator decal, COMF, 35 amp 352, 430 with AC . . . . . DF454 4.95
- 63-66 Voltage regulator radio warning tag . . . . . DF320 3.95



- 1961 Voltage regulator decal, C1TF-B, 30 amp, no AC . . . . . DF530 4.95
- 1961 Voltage regulator decal, C1TF, 40 amp, with AC . . . . . DF1101 4.95
- 1962 Voltage regulator decal, C2SZ-B, after 5-21-62, 35 amp, no AC . . . . . DF1104 4.95



- 1962 Voltage regulator decal, C2SF, 40 amp, with AC . . . . . DF825 4.95
- 1963 Voltage regulator decal, C3XF, 30 amp, with AC . . . . . DF500 4.95
- 1963 Voltage regulator decal, C3TF, 40 amp . . . . . DF496 4.95



- 1963 Voltage regulator decal, C4TF-A, 30 & 40 amp, late 1963 . . . . . DF453 4.95
- 61-62 Voltage regulator radio warning decal . . . . . DF347 4.95 pair
- 1964 Voltage regulator decal, C4OF, 40 amp, no AC . . . . . DF408 4.95



- 1964 Voltage regulator decal, C4TF-B, 52 amp, transistorized ignition . . . . . DF495 4.95
- 65-66 Voltage regulator decal, C5TF-A, with AC or convertible top . . . . . DF412 4.95



## Engine Compartment Decals (continued)

### Miscellaneous

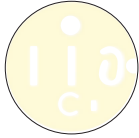

- 55-57 Engine foundry tag . . . . . DF229 4.95
- 55-57 Non-aluminum valve cover . . . . . DF1074 10.95 pair



- 1956 Paint OK decal set, 12 Volt 3-23-56 . . . . . DF236 4.95 set
- 1957 Paint OK decal set, 12 Volt . . . . . DF237 4.95 set

## Trunk Decals



- 55-56 Jack instruction decal . . . . . DF40 2.95
- 1957 Jack instruction decal . . . . . DF41 3.95

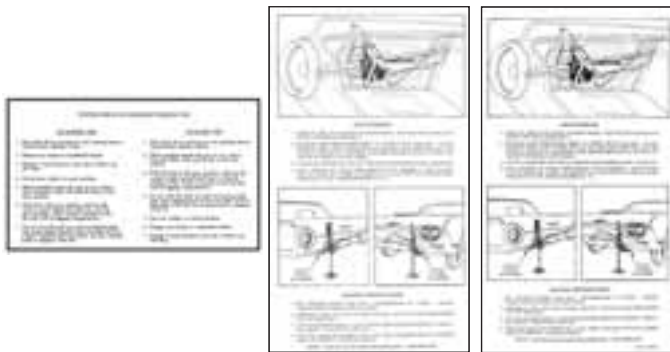

- 58-60 Convertible top operation . . . . . DF547 3.95
- 1961 Jack instructions . . . . . DF513 3.95
- 1962 Jack instructions, **except** Sports Roadster. DF132 2.95



- 62-63 Jack instructions, Thunderbird Sports Roadster only . . . . . DF434 3.95
- 1963 Jack instructions . . . . . DF219 3.95
- 1964 Jack instructions . . . . . DF249 3.95

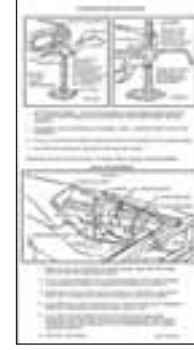
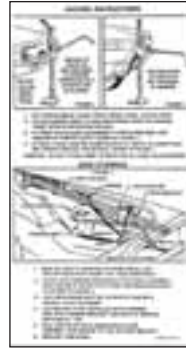

- 1965 Jack instructions . . . . . DF290 3.95
- 1966 Jack instructions . . . . . DF238 3.95

## Interior Decals

### Glove Box Door



- 55-56 Glove box tire pressure decal . . . . . DF80 3.95
- 55-57 Glove box door automatic transmission decal. DF81 3.95
- 55-57 Glove box door, folding top decal . . . . . DF90 3.95
- 1957 Glovebox door engine oil / tire pressure decal. . DF79 1.95



- 62-63 Glove box tire pressure decal . . . . . DF369 3.95
- 62-64 Tonneau glove box warning, Sports Roadster. DF269 3.95
- 1966 Glove box tire pressure decal, convertible . DF293 3.95
- 1966 Glove box tire pressure decal, coupe . . . . . DF294 3.95

### Lifeguard



- 1957 Lifeguard body door decal . . . . . DF93 3.95
- 1957 Lifeguard door lock decal . . . . . DF180 4.95

### Schematics

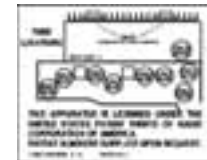
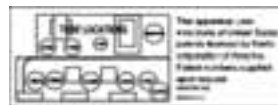

- 1956 Radio schematic decal . . . . . DF273 2.95
- 1957 Radio schematic decal . . . . . DF274 2.95



- 1964 Kick panel decal, schematic for fuse box . DF1108 4.95
- 1965 Kick panel decal, schematic for fuse box . DF1105 4.95
- 1966 Kick panel decal, schematic for fuse box . . DF512 4.95



**New Car Stickers & Price Lists**



- 1959 New car window price sticker . . . . . DF186 4.95
- 1960 New car window price sticker . . . . . DF187 4.95
- 1961 New car window price sticker . . . . . DF188 4.95
- 1962 New car window price sticker (early 1962) . . . . . DF903 4.95
- 1962 New car window price sticker (late 1962) . . . . . DF189 4.95
- 1963 New car window price sticker . . . . . DF190 4.95
- 1964 New car window price sticker (early 1964) . . . . . DF904 4.95
- 1964 New car window price sticker (late 1964) . . . . . DF191 4.95
- 1965 New car window price sticker . . . . . DF192 4.95
- 1966 New car window price sticker . . . . . DF193 4.95



- 1959 New car accessory price list . . . . . DF209 2.95
- 1960 New car accessory price list . . . . . DF210 2.95
- 1961 New car accessory price list . . . . . DF211 2.95
- 1962 New car accessory price list . . . . . DF212 2.95
- 1963 New car accessory price list . . . . . DF213 2.95
- 1964 New car accessory price list . . . . . DF214 2.95
- 1965 New car accessory price list . . . . . DF215 2.95
- 1966 New car accessory price list . . . . . DF216 2.95

**Miscellaneous**



- 55-56 Electric clock instruction booklet . . . . . DF156 3.95
- 56-57 Battery warranty card . . . . . DF117 2.95
- 1955 Service policy . . . . . DF445 2.95
- 55-56 Glare-proof mirror instruction decal . . . . . DF154 2.95

**Nostalgia Decals**



- ALL Ford drag team 5" . . . . . DZ115 4.95
- ALL Ford drag team 8" . . . . . DZ116 5.95



- ALL 3-1/2" blue oval decal, "Ford" script lettering on a white background . . . . . DF361 3.00
- ALL 6-1/2" blue oval decal, "Ford" script lettering on a white background . . . . . DF362 3.75
- ALL 9-1/2" blue oval decal, "Ford" script lettering on a white background . . . . . DF363 4.25
- ALL 17" blue oval decal, "Ford" script lettering on a white background . . . . . DF364 5.05
- ALL **NEW** 17" blue oval decal, "Ford" script lettering on a clear background . . . . . DF1391 5.95



- ALL 3" "Ford Genuine Parts" decal . . . . . DF531 3.00



- ALL **NEW** Smithy's muffer decal . . . . . DZ309 4.95
- ALL Muscle Power inside window decal . . . . . DZ113 5.95
- ALL Muscle Power exterior decal . . . . . DZ114 5.95
- ALL 5" Muscle Power window decal, inside . . . . . DZ185 5.95
- ALL 5" Muscle Power window decal, outside . . . . . DZ186 5.95

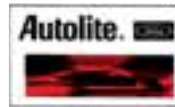

- ALL 1-1/2" x 2-1/2" Ford Autolite decal . . . . . DZ120 4.95
- 55-57 4" Autolite sparkplug circle decal . . . . . DZ5 4.95
- 55-57 6-1/2" Autolite sparkplug circle decal . . . . . DZ4 5.95



- 55-57 6,000 mile or 6 month lube sticker, Ford . . . . . DF746 2.95
- 55-57 Auto Racing Club of America . . . . . DZ36 4.95



- ALL Island dragway, NHRA Class Winner window decal . . . . . DZ61 4.95
- ALL Kil-Kare dragstrip . . . . . DZ154 5.95
- ALL Lions dragstrip . . . . . DZ215 4.95

Continued on the next page



# DECALS & TAGS



## Nostalgia Decals (continued)

- |                                                                 |                                                 |                                                    |
|-----------------------------------------------------------------|-------------------------------------------------|----------------------------------------------------|
|                                                                 |                                                 |                                                    |
| ALL Cecil County Dragway Super Stock Factory Showdown . . . . . | ALL NASCAR Drag Racing Division decal . . . . . | ALL Phenix Dragway, Phenix City, Alabama . . . . . |
| DZ221                                                           | DZ247                                           | DZ91                                               |
| 4.95                                                            | 4.95                                            | 4.95                                               |

- |                                               |                                             |                                           |
|-----------------------------------------------|---------------------------------------------|-------------------------------------------|
|                                               |                                             |                                           |
| ALL Phoenix International Dragstrip . . . . . | ALL Phoenix Dragstrip race driver . . . . . | ALL Ted Edwards Dragstrip decal . . . . . |
| DZ81                                          | DZ170                                       | DZ244                                     |
| 4.95                                          | 4.95                                        | 3.95                                      |

- |                                               |                                                    |                              |
|-----------------------------------------------|----------------------------------------------------|------------------------------|
|                                               |                                                    |                              |
| ALL United Racing Association decal . . . . . | ALL United Drag Racers Association decal . . . . . | ALL U.S. Auto Club . . . . . |
| DZ105                                         | DZ212                                              | DZ69                         |
| 5.95                                          | 4.95                                               | 5.95                         |

- |                                     |                                   |                                                         |
|-------------------------------------|-----------------------------------|---------------------------------------------------------|
|                                     |                                   |                                                         |
| ALL Westhampton Dragstrip . . . . . | ALL NASCAR, early 1950s . . . . . | 1951 Bonneville, Hop-Up Magazine window decal . . . . . |
| DZ163                               | DZ63                              | DZ37                                                    |
| 4.95                                | 4.95                              | 4.95                                                    |

- |                                                  |                                                         |                                                          |
|--------------------------------------------------|---------------------------------------------------------|----------------------------------------------------------|
|                                                  |                                                         |                                                          |
| 1952 Bonneville, Sta-Lube window decal . . . . . | 1953 Bonneville, Bell Auto parts window decal . . . . . | 1954 Bonneville, Iskenderian Cams window decal . . . . . |
| DZ39                                             | DZ38                                                    | DZ40                                                     |
| 5.95                                             | 5.95                                                    | 5.95                                                     |

- |                             |
|-----------------------------|
|                             |
| 1954 NASCAR decal . . . . . |
| DZ194                       |
| 5.95                        |
| 1955 NASCAR decal . . . . . |
| DZ195                       |
| 5.95                        |
| 1956 NASCAR decal . . . . . |
| DZ198                       |
| 5.95                        |
| 1957 NASCAR decal . . . . . |
| DZ193                       |
| 5.95                        |
| 1958 NASCAR decal . . . . . |
| DZ197                       |
| 5.95                        |
| 1959 NASCAR decal . . . . . |
| DZ196                       |
| 5.95                        |

- |                                                          |                                                                |                                 |                                                |
|----------------------------------------------------------|----------------------------------------------------------------|---------------------------------|------------------------------------------------|
|                                                          |                                                                |                                 |                                                |
| 1957 Bonneville, Iskenderian Cams window decal . . . . . | 1959 NHRA, Moon Equipment 1959 Nationals Participant . . . . . | 1960s NASCAR Race Car . . . . . | 1964 Winternationals NHRA 1964 decal . . . . . |
| DZ41                                                     | DZ150                                                          | DZ31                            | DZ30                                           |
| 5.95                                                     | 5.95                                                           | 5.95                            | 5.95                                           |



- |      |                                                           |       |      |
|------|-----------------------------------------------------------|-------|------|
| 1968 | 1968 NHRA World Series Contestant decal . . . . .         | DZ203 | 4.95 |
| 1970 | 1970 NHRA World Series Contestant decal . . . . .         | DZ202 | 4.95 |
| 1974 | 1974 NHRA World Series Contestant decal . . . . .         | DZ201 | 4.95 |
| 1975 | Pomona, NHRA 1975 Winternationals Participant . . . . .   | DZ174 | 4.95 |
| 1979 | Bakersfield 1979 Bracket Finals Qualifier decal . . . . . | DZ173 | 4.95 |

## Bumper Stickers

- |                                                  |
|--------------------------------------------------|
|                                                  |
| ALL My other car is a classic Mustang! . . . . . |
| BS74                                             |
| 2.95                                             |

- |                                  |
|----------------------------------|
|                                  |
| ALL You drive a Chevy! . . . . . |
| BS64                             |
| 2.95                             |

- |                                  |
|----------------------------------|
|                                  |
| ALL You drive a Mopar! . . . . . |
| BS65                             |
| 2.95                             |

- |                                                        |
|--------------------------------------------------------|
|                                                        |
| ALL I'd rather eat worms than drive a Chevy! . . . . . |
| BS67                                                   |
| 2.95                                                   |

- |                                                        |
|--------------------------------------------------------|
|                                                        |
| ALL I'd rather eat worms than drive a Mopar! . . . . . |
| BS68                                                   |
| 2.95                                                   |

- |                                                     |
|-----------------------------------------------------|
|                                                     |
| ALL Friends don't let friends drive Chevys. . . . . |
| BS69                                                |
| 2.95                                                |

- |                                                     |
|-----------------------------------------------------|
|                                                     |
| ALL Friends don't let friends drive Mopars. . . . . |
| BS71                                                |
| 2.95                                                |

- |                                                                      |
|----------------------------------------------------------------------|
|                                                                      |
| ALL Carroll Shelby is alive & well & living under the hood . . . . . |
| BS73                                                                 |
| 2.95                                                                 |



**Thunderbird Specialty Books**

This 304-page book by Ray Miller tracks the Little Bird into the 1970s. It gives you all the information on the Thunderbird that you will need to correctly restore it to its original glory. It covers each model year by giving all the year's subtle differences & shows you what everything on the car does & how it does it. It even goes as far as showing where decals are located. Also included are the years from 1958-1966 & into the '70s.

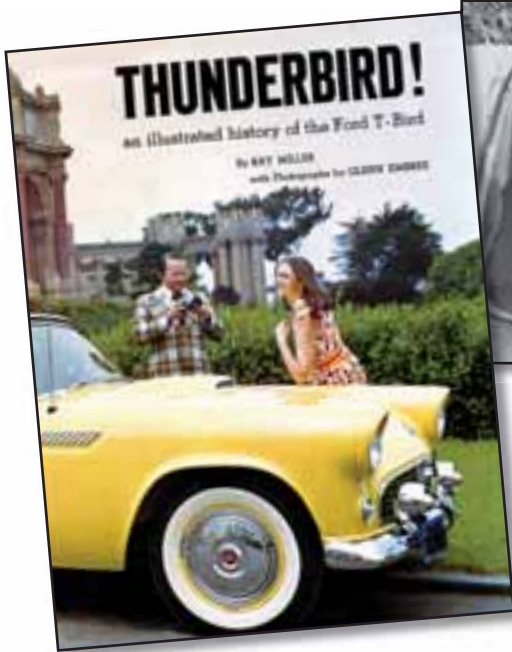

"THUNDERBIRD!" is not an amateur's photo album. Neither is it a complex engineering notebook containing, to be sure, the significant changes, but also the trivia of the model years. Rather, it is what it set out to be, an accurate & authoritative study of the characteristics that make for a typical "model year." Future restorers will benefit from its compact, succinct & definitive presentations. It is a book to be enjoyed by the curious, welcomed by the purist & relished by the aficionado. We give to you for your enjoyment . . . ."

Ray Miller  
THUNDERBIRD! an illustrated history of Ford's T-Bird

ALL **THUNDERBIRD: An Illustrated History Of The Ford T-Bird** . . . . . VB1000 53.75

55-57 **Thunderbird Performance Portfolio 1955-57** . . . . . BK032AE 22.95

This Brooklands book is 140 pages softbound & has 180 illustrations that evaluate Ford's two-seat sports car with road tests. Front to back, it is full of illustrations of the actual ads that were used to introduce & advertise these beauties. There are road & comparison tests, specifications, performance data, drive reports & consumer analysis.

55-70 **1955-1970 Thunderbird Illustrated I.D. Decoder Manual**, softbound, 59 pages, more than 20 illustrations. . . . . BK2DM55 7.95

This small decoder book makes the perfect companion for the auto auction scene. When that special "find" of the auction is available for viewing you can verify the data plate codes & tuck this book in your shirt pocket when you are done.

55-93 **Thunderbird ID Numbers, 1955-93**, softbound, 229 pages, more than 90 black & white photographs, 54 page color section on exterior paint & interior trim . . . . . BK52414 24.95

Compiled by the staff of Cars & Parts magazine, this book determines what the numbers & letters on your data plate stand for. Starting with the VIN number it explains what every digit means & then breaks down all the codes used by Ford. A detailed list of "regular production options" (RPO) is listed for every year from 1955 thru 1993. A special section gives you the lowdown on deciphering date codes & casting numbers.

55-57 **Ford & Thunderbird Body Parts Catalog**, 456 pages of text & technical illustrations for the Thunderbird. . . . . VB53 42.75

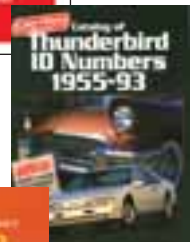





## Shop Manuals

The following manuals are the comprehensive sources on all aspects of servicing parts, assemblies & systems of the Ford Thunderbird. Ford Motor Company sent these to Ford dealerships to instruct mechanics how to remove & replace most major components on new Thunderbirds. These are correct reprints of those original shop manuals. Each manual outlines procedures for replacement, adjustment & trouble-shooting, from basic operations like transmissions, brakes & chassis to accessories & instrumentation. No Thunderbird enthusiast or restorer should be without one!

### Concours-Quality For Display



1955	341 pages	VB55	28.95
1956	368 pages	BK846A	29.95
1957	Over 500 pages	BK121A	29.95
1958	340 pages	BK258SM	34.95



1959	421 pages	BK259SM	34.95
1960	384 pages	BK260SM	34.95
1961	322 pages	BK261SM	34.95
62-63	314 pages	BK262SM	34.95



1963	<b>Supplement</b> , this only lists the changes from the 1962 version, so the 1962 Shop Manual is required to make this a complete shop manual, 62 pages	BK263SM	23.95
1964	396 pages	BK264SM	31.95
1965	426 pages	BK265SM	31.95
1966	432 pages	BK266SM	34.95

## Electrical Assembly Manuals

Reprints of original Ford electrical system assembly manuals. These books are incredibly valuable to anyone working on Thunderbird electrical systems.



1955	35 pages	BK4EM55	15.95
1956	47 pages	BK4EM56	15.95
1957	53 pages	BK4EM57	15.95
1959	86 pages	BK2EM59	15.95
1960	107 pages	BK2EM60	15.95
1961	88 pages	BK2EM61	15.95
1962	88 pages	BK2EM62	15.95
1963	79 pages	BK2EM63	15.95
1964	74 pages	BK2EM64	15.95
1965	89 pages	BK2EM65	15.95
1966	93 pages	BK2EM66	15.95

## Thunderbird Body, Interior Assembly Manuals

Officially licensed collection of Ford body engineering installation & trim diagrams, close-ups & step-by-step instructions, reprinted from original Ford Body, Interior Assembly Manuals. You will not find a more comprehensive guidebook for Thunderbird interior restoration.



1962	96 pages	BK2BIM62	25.95
1964	92 pages	BK2BIM64	25.95
1965	97 pages	BK2BIM65	25.95
1966	112 pages	BK2BIM66	25.95

## Thunderbird Body, Trim & Sealant Assembly Manuals

If you are doing a ground up restoration this book should be required reading. Reprints of the incredibly detailed engineering drawings from Ford Motor Companies archives, showing every area that was sealed, all the sound deadener & even some weatherstripping details.



1957	53 pages	BK4BTSM57	25.95
1958	76 pages	BK2BTSM58	25.95
1959	72 pages	BK2BTSM59	25.95
1960	73 pages	BK2BTSM60	25.95
1961	84 pages	BK2BTSM61	25.95
1963	104 pages	BK2BTSM63	25.95





### Convertible Top Repair & Adjustment Manuals

These manuals include sections covering maintenance & adjustments, component replacement & in the event your top won't open or close or gets stuck, a handy troubleshooting guide.



58-60	30 pages	BK2CT58	6.95
61-63	16 pages	BK2CT61	6.95
64-66	36 pages	BK2CT64	6.95

### Wiring Diagram Manuals

The following manuals contain highly detailed, easy-to-follow diagrams for Thunderbird wiring. Each one has the specific information for the chassis, instrumentation & turn signals of your car, as well as additional material. Wiring can be dangerous & can lead to problems if not installed properly, so having one of these manuals could save you a lot of time & money.



1955	8 pages	BK1WM55	7.95
1956	8 pages	BK1WM56	7.95
1957	8 pages	BK1WM57	7.95
1958	8 pages	BK2WD58	6.95
1959	6 pages	BK2WD59	6.95
1960	6 pages	BK2WD60	6.95
1961	4 pages	BK2WD61	6.95
1962	4 pages	BK2WD62	6.95
1963	17 pages	BK2WD63	6.95
1964	21 pages	BK2WD64	6.95
1965	16 pages	BK2WD65	6.95
1966	20 pages	BK2WD66	6.95

### Owners Manuals

The following owners manuals are reprints of the original manual that was included with the car. They are a tremendous resource of information about your Thunderbird & are great for displaying at car shows. Each manual covers everything from driving the car to its maintenance & specifications, using numerous illustrations. In addition to their value as sources of information, these manuals are also attractive for the collector.



1955	64 illustrated pages	BK4OM55	8.95
1956	64 pages, 52 illustrations	BK866A	6.95
1957	64 illustrated pages	BK867A	6.95



1958	40 illustrated pages	BK2OM58	16.95
1959	40 illustrated pages	BK2OM59	16.95
1960	60 pages, 40 illustrations	BK2OM60	16.95
1961	64 illustrated pages	BK2OM61	16.95
1962	65 pages, over 60 illustrations	BK2OM62	16.95
1963	65 pages, over 50 illustrations, includes Ford Registered Owner Plan.	BK2OM63	16.95



1964	65 pages, 73 illustrations, includes Ford Registered Owner Plan	BK2OM64	16.95
1965	68 pages, over 70 illustrations, includes Ford Registered Owner Plan	BK2OM65	16.95
1966	69 pages, over 70 illustrations, includes Ford Registered Owner Plan	BK2OM66	16.95

### Owners Manual Envelopes

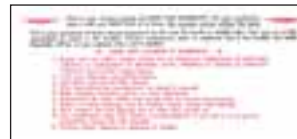

59-60	DF335	3.95
61-62	DF648	3.95

### Facts & Feature Manuals

These reprints from Ford data manuals cover paint, trim, interiors, powertrain availability & options, accessories & safety features available for your car. No more guessing: all the facts, according to Ford.



1958	16 illustrated pages	BK2FF58	6.95
1959	16 illustrated pages	BK2FF59	6.95
1960	16 illustrated pages	BK2FF60	6.95
1962	16 illustrated pages	BK2FF62	6.95
1963	22 illustrated pages	BK2FF63	6.95
1964	14 illustrated pages	BK2FF64	6.95
1965	18 illustrated pages	BK2FF65	6.95
1966	18 pages, 40 plus illustrations	BK2FF66	6.95

### Dealer Sales Brochures

These quality reprints of Ford dealer sales brochures are perfect for display at a car show!

1955	Thunderbird Foldout Brochure	BK4DSB55	7.95
1956	Thunderbird Foldout Brochure	BK4DSB56	7.95
1957	Thunderbird Foldout Brochure	BK4DSB57	7.95
1958	Thunderbird Foldout Brochure	BK2DSB58	5.95
1959	Thunderbird Foldout Brochure	BK2DSB59	5.95
1960	Thunderbird Foldout Brochure	BK2DSB60	5.95
1961	Thunderbird Foldout Brochure	BK2DSB61	7.95



## All Ford Products Engine Equipment Assembly Manuals

These books are officially licensed collections of Ford technical illustrations of external engine components (alternator, power steering pump, choke lines—almost anything that mounts outside of the block), reprinted from original Ford assembly manuals.



1963 38 pages . . . . . BK1EEM63 15.95  
 1964 46 pages . . . . . BK1EEM64 15.95



1965 33 pages . . . . . BK1EEM65 15.95  
 1966 157 pages . . . . . BK1EEM66 15.95



1967 253 pages . . . . . BK1EEM67 15.95

## Identification Books



64-04 **Standard Catalog Of Mustang 1964-2004**, by John Gunnell, FULL COLOR! This full size, softcover book combines history, photos, buyer's guide information, technical specifications & pricing into one handy easy-to-use publication, 304 pages & 500 color photos . . . . . BK305 24.95

1960-2000 **Field Guide To Muscle Cars, American Supercars 1960-2000**, by John Gunnell, don't let the small size format (5-1/8" x 4-1/4") of this book fool you, it features 188 cars, each having a full page photo & another page devoted to production data, engine specs & popular options, this is the book to have if you love American muscle cars, 400 pages, more than 180 illustrations . . . . . BK1020 14.95

1886-2000 **Standard Catalog Of American Light Duty Trucks**, 500 truck listings from 1896-2000, included manufacturing mini-histories, 800 pages, 2,300 photos . . . . . BK2389 34.95

## Source Guides & Interchange Books



50-65 **Ford Products Interchange Manual**, by Auto Interchange Systems, 160 pages, 253 photos, lists identically-used parts on all American Ford products from 1950-1965, designed to save time locating the parts you need, invaluable for the owner or restorer . . . . . SRB941C 44.95

59-70 **Ford Parts Interchange Manual**, covers Mustang, Fairlane, Torino & Mercury Cougar & Cyclone, a great resource for improving your odds of finding the part you need at swap meets, salvage yards, or even at retail for less, 224 pages, 206 illustrations . . . . . BK151PI 23.95

63-74 **Ford Products Interchange Manual**, by Auto Interchange Systems, this softbound book lists parts interchanges for major parts groups including axle, bearing, brake, clutch, cooling, suspension & more, 278 pages . . . . . BK194C 44.95

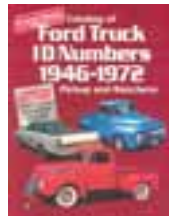

46-72 **Catalog Of Ford Truck ID Numbers**, for pickups & Rancheros, this book gives codes for VIN tags, body plates, engines & transmissions & includes color & trim information, 245 pages . . . . . BK52403 24.95

ALL **Parts Locating Guide—Mustang & Mercury Cougar**, a listing of hundreds of parts dealers, salvage yards, literature & performance parts dealers, clubs & restoration & rebuild services, 152 pages, 52 illustrations . . . . . BK053D 27.95

ALL **Ford Restoration Sources**, a comprehensive listing of parts & literature, dealers, repair & restoration companies, specialty salvage yards, appraisers & clubs, all listed by section for easy use, excellent resource for the restorer, 100 pages . . . . . BK054D 27.95

ALL **Ford Truck & Ranchero Restoration Sources**, a listing of hundreds of parts dealers, salvage yards, literature dealers, repair & restoration companies, appraisers, insurance & transport companies, 106 pages, 9 illustrations. . . BK055D 27.95



**Sheetmetal & Welding Books**



- ALL **Performance Welding**, by Richard Finch, this guide covers techniques used for Indy, NASCAR & experimental aircraft, your guide to making high-quality welds with 4130 steel, aluminum & stainless, how to select equipment & choose the right process & fill metal for each project, 160 pages with 250 illustrations . . . . BK530AP 18.95
- ALL **Sheetmetal Handbook**, by Ron & Sue Fornier, shows you how to form & shape sheet metal using hammer forming, riveting, layout, design & pattern-making, 144 pages . . . BK575 16.95

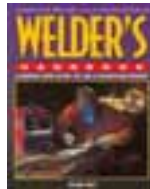

- ALL **Metal Fabricator's Handbook**, by Ron & Sue Fornier, over 350 step-by-step photos & instructions teach proper welding, metal shaping & design techniques for bodywork, fuel & oil tanks & exhaust headers, 175 pages. . . . . BK709 16.95
- ALL **Welder's Handbook, 2nd Edition**, by Richard Finch, the complete guide to MIG, TIG, oxyacetylene & arc welding, weld like the pros! Sections include brazing, cutting, soldering, plasma cutting master materials like mild steel, aluminum, chrome-moly, magnesium & titanium, 169 pages . . . . BK1264 19.95

**Restoration Books**

**Paint**

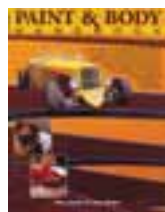
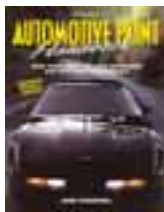

- ALL **Automotive Paint Handbook**, by John Pfanstiehl, revised & updated, master the #1 appearance item on your car—the paint! Chip repair & paint care for the restorer, learn paint basics, equipment & regulations, spot repainting, custom painting, detailing & finessing, 180 pages. . . . . BK1291 16.95
- ALL **Paint & Body Handbook**, by Don Taylor & Larry Hofer, over 450 illustrations & easy-to-read text show how to repair dents, rust, aluminum & fiberglass, also learn to use lead, plastic filler, weld patches & do spot repairs. How to avoid & correct blistering, blushing, orange peel & more, 144 pages . . . . BK1082 19.95

**Upholstery**

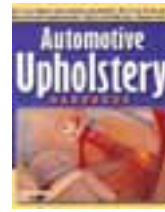

- ALL **Automotive Upholstery Handbook**, by Don Taylor, how to use tools, fasteners & materials, how to cut, fit, sew & install complete interiors, vinyl & convertible tops & tonneau covers, 232 pages with more than 550 illustrations. . . . . BK755C 21.95
- ALL **Auto Upholstery & Interiors**, by Bruce Caldwell, a basic do-it-yourself guide to repairing, replacing, or customizing auto interiors, it was written expressly for the home enthusiast, 136 pages . . . . . BK1265 19.95

**Detailing & Trim; Fiberglass**

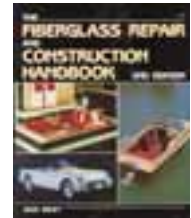

- ALL **How To Restore Metal Auto Trim**, by the auto trim expert, Jeff Lilly, step-by-step information to restore & repair aluminum & stainless steel trim on your classic, covers essential tools & materials, what you'll need & where to get them, 96 illustrated pages. . . . . BK1RG1 19.95
- ALL **The Fiberglass & Construction Handbook**, includes fiberglass facts, materials, tools, equipment, supplies & work area, discusses fundamentals moulding methods, structural & assembly concepts & practices, includes covering wood with fiberglass & fiberglass products in kits, 216 pages, 221 illustrations . . . . . SRB692A 23.25





## Transmission & Engine Rebuilding Books



- 32-53 **Rebuilding The Famous Ford Flathead**, a step-by-step approach to rebuilding the V-8 flathead, covers all models from 1932 to 1953, a necessary guide for the flathead rebuilder, 140 pages, 81 detailed diagrams . . . . . VB124 14.95
- 32-53 **Ford Flathead V-8 Builder's Handbook 1932-1953**, with tips on rebuilding Ford & Mercury V-8 flatheads for stock & high performance, covers boring, stroking, porting & relieving, 500 illustrations in 154 pages . . . . . VB160 19.95
- 49-51 **1949-51 Lincoln & Mercury Overhaul Set & Shop Manual**, includes automatic transmission supplements & wiring diagrams, 860 plus illustrated pages . . . . . BK1SM1 64.95

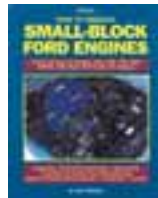
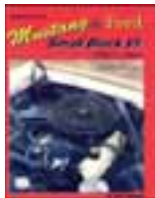

- 49-53 **Thunder Road Flathead**, by Bill Jenkins has 10 valuable chapters of procedures, ideas & modifications for 1949-1953 Ford & Mercury flatheads, 84 page book, 61 photos . . . BK474D 28.95
- 62-69 **Mustang & Ford Small Block V-8**, by Bob Mannel, volumes 1 & 2 under one cover! 736 pages with nearly 3,000 photos detail engine colors, decal placement, casting numbers & more! . . . . . BK3SB1 63.95
- 62-78 **How To Rebuild Small-Block Ford Engines**, detailed guide covers the step-by-step rebuilding process, a necessity for small-block Ford owners & mechanics, 160 pages with 567 illustrations . . . . . BK89 18.95

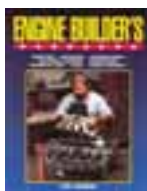
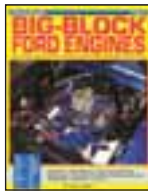

- 60-72 **How To Rebuild V-8 Ford Engines**, accurately details all rebuilding steps, organized in an easy one-step-at-a-time format, covers 351C, 351M, 400, 429 & 460 engines, 160 pages, 560 photos & drawings . . . . . BK36 17.95
- ALL **How To Rebuild Big-Block Ford Engines**, charts, drawings & diagrams, tips on engine removal, disassembly, parts reconditioning, assembly & installation, includes complete section on parts identification & swapping, all years & models of FE & FT engines used in Ford & Mercury passenger cars & Ford trucks, 160 pages with 500 photos . . . . . BK708 16.95
- ALL **Engine Builder's Handbook**, by Tom Monroe, a complete, illustrated guide to professional blueprinting & assembly techniques, written for the serious enthusiast as well as the professional, 169 pages . . . . . BK1245 16.95

## Electrical Books

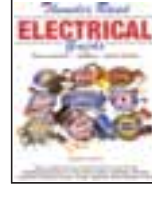
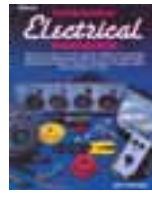

- ALL **Automotive Electrical Handbook**, complete guide to automotive wiring, covers terminology, troubleshooting, 6-to-12 volt conversion & system designing, glossary of terms & symbols, 159 pages . . . . . BK387 19.95
- ALL **Thunder Road Electrical Guide**, a guide for antiques, rods, customs & racing vehicles on pros & cons & how-to's of converting a 6 volt system to 12 volts, 137 pages . . . . . BK475D 28.95

## Carburetor Books

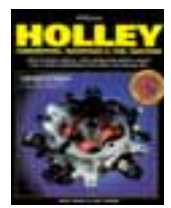

- 55-73 **Ford Carburetor Guide, 1955-1973, 2nd edition**, by Pony Carburetors, Inc., a comprehensive identification guide for all Ford, Lincoln & Mercury carburetors, charts for decoding carburetor tags, description & history for each carburetor type & series, application charts itemized by year, car line & engine size, over 100 pages with photographs . . . . . BK1CARB1 15.95
- ALL **Rochester Carburetors**, thoroughly explains theory, service & performance techniques, also gives detailed information on performance modifications, great tool for rebuilding Rochester carburetors, 176 pages, 650 illustrations . . . . . BK014 16.95
- ALL **Holley Carburetors & Manifolds**, this book has carburetion basics, installation guidelines & tips on tuning, modification & troubleshooting, it also provides the "inside edge" on Holley carbs & manifolds, 224 pages & more than 500 photos, charts, illustrations & diagrams . . . . . BK1052 16.95

## Performance Books, Engine



- 62-63 **Ford 406 High-performance Engine Parts & Accessories**, this 8 page brochure features 7 illustrations & specifications for engines, parts & accessories. . . . . BK1AF62 6.95
- 63-64 **Ford 427 High-performance Part & Accessories Folder**, this 4 page folder is the most comprehensive resource on Ford 427 engines, listing everything from axles & engine parts to electrical accessories. . . . . BK1AF63 5.95
- 1963 **Ford Galaxie 427 Homologation Record**, detailed, 9 page record specifically for owners of the Ford Galaxie 427, 19 illustrations . . . . . BK1FG63 6.95



**Ford Road Series**

Authored by Ray Miller, these books track each model from drawing board to showroom to customer. Overflowing with black & white photos of the cars, Ray's books document styling changes from year to year & show optional equipment & differences in trim. The Ford Road Series is the most thoroughly informative & most intensely illustrated

reference collection available for these cars. With masterful photography throughout, these books are not only great sources of information; they are also attractive show pieces for the concours or the coffee table.

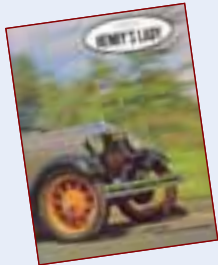

- 09-27 **FROM HERE TO OBSCURITY**, hard bound, year by year detailed information, most complete coverage available, all years & body styles, 293 pages, 950 pictures . . . .128 34.00
- 28-31 **HENRY'S LADY**, illustrated history of the Model A Ford Car, great detail, 304 pages, 1029 photos . . . . . P7A 53.75
- 32-42 **THE V-8 AFFAIR**, highlights body & trim changes of the new V-8 powered Fords, includes a 22 page specification section loaded with charts, including production figures, for all years, 303 pages, over 800 photos & a special 8 page color section . . . . . VB81 53.75

- 46-59 **THE NIFTY FIFTIES FORD**, mammoth 320 page volume detailing annual styling changes from 1946-1959, using more than 1,200 illustrations! . . . . . VB1001 51.95
- 55-66 **THUNDERBIRD: AN ILLUSTRATED HISTORY OF THE FORD T-BIRD**, includes a special full-color section, 300 pages, with over 1,000 illustrations . . . . . VB1000 53.75
- 59-70 **FALCON! THE NEW-SIZE FORD**, shows this new "compact" car from every angle, illustrating the trim differences between many models, also included are production statistics, a chart to help decode the data plate & photos of typical over-the-counter accessories, some fairly common & some now very rare, 320 pages with more than 1,300 photo's . . . . . VB1003 51.95

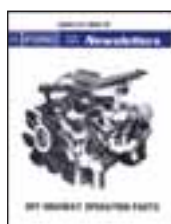
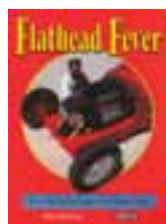

- ALL **Flathead Fever**, revised, charts how to Hot Rod the famous Ford Flathead engine, a step-by-step guide to the entire buildups of Flathead fitted to a couple of Ford Roadsters, 80 pages, 142 black & white illustrations, diagrams . . . . . BK830AE 16.95
- 63-72 **Ford O.H.O. Parts Newsletters**, an excellent source of parts information, specifications & installation details, this 38 page manual includes 94 illustrations & photos for the Ford dealer & the off-road enthusiast . . . . . BK120A 8.95
- 61-73 **Hi-Per Parts**, a catalog of special high-performance parts for big block engines (390, 406, 427 & 428) & detailed instructions for peak performance, it's the ideal reference for maintaining a finely-tuned high-output engine, 38 pages with 68 illustrations . . . . . BK227A 17.95

**Brooklands Road Test Books**

Edited by R.M. Clarke, these softbound treasures contain information not available anywhere else. The articles, originally printed in automotive magazines & written by the world's automotive experts, include test drive results, technical data, performance statistics & new model comparisons. Find out what they were saying & thinking back when your car was new & see how your classic stacked up against the competition of its day.

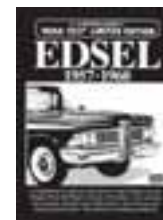
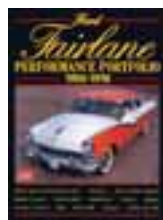

- 55-70 **Ford Fairlane Performance Portfolio, 1955-1970**, 140 pages, 180 black & white illustrations . . . . . BK365A 22.95
- 57-79 **Ford Ranchero Muscle Portfolio, 1957-1979**, approximately 100 pages, 180 illustrations . . . . . BK973A 22.95
- 58-60 **Edsel**, 92 pages, over 160 illustrations . . BK714B 22.95



- 60-70 **Falcon Performance Portfolio, 1960-1970**, 100 pages, 180 illustrations . . . . . BK401B 22.95
- 66-77 **Ford Bronco 4x4 Performance Portfolio**, 100 pages, 180 illustrations . . . . . BK597A 22.95





## History of Ford & Mercury Books

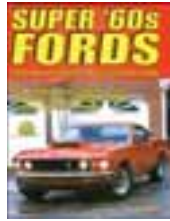
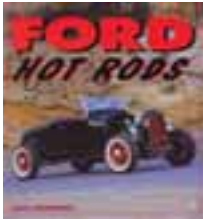

- 09-69 **Ford Hot Rods**, by Dain Gingerelli, 96 illustrated pages follow the hot rods from the Model T to the 1960s, includes quotations from Henry Ford . . . . . BK164AP 14.95
- ALL **Super '60s Fords**, by John Smith, performance cars were the kings of the '60s, lists performance engines & stats for each year & includes info to help you decipher your VIN tags & parts codes, 160 pages with 100 color & 200 black & white photos . . . . . BK1706 24.95

## Truck Books

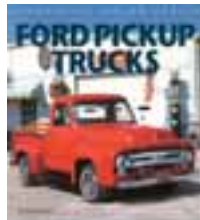

- ALL **Ford Truck & Ranchero Restoration Resources**, a listing of hundreds of parts dealers, salvage yards, literature dealers, repair & restoration companies, appraisers & insurance & transport companies, 106 pages, 9 illustrations . . . BK055D 27.95
- 48-94 **Ford Pickup Trucks Color History**, a full-color gallery of classic Ford pickup trucks, from Model T to Ranger & Bronco, 96 pages, 75 color photos . . . . . BK461AP 15.95



- 46-47 **How To Restore Your Ford Pickup**, step-by-step restoration guide, body, box, engine, electrical, paint, metal & glass, 224 pages . . . . . VB251 24.95
- 32-52 **Pickup Book**, good restoration guide for pick-ups, 140 pages . . . . . VB88 16.95

## Chevy Books



- ALL **How To Rebuild Your Small-Block Chevy**, guides you thru the complete rebuilding process, easy-to-read, user-friendly format, a necessity for the Chevy man! 167 pages & softbound color cover. . . . . BK1029 16.95
- 55-57 **Chevrolet Shop Manual (car)**, complete, 1955, 1956 Supplement & 1957 Shop Manuals in a single deluxe master volume, 1,464 pages. . . . . CV 32.95

## Non-Ford Books

### Catalogs Of American Car ID Numbers

An extensive guide to decoding VIN tags, body plates, engine numbers & paint & trim codes, organized by car maker, an in-depth & detailed guide from the staff at Cars & Parts magazine.

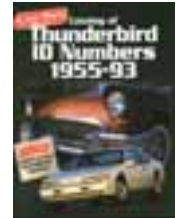
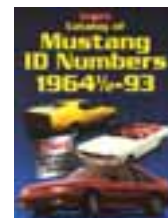
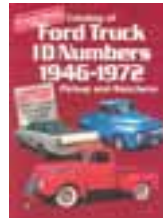

- 46-72 **Catalog Of Ford Truck ID Numbers 1946-1972**, codes for VIN tags, body plates, engine & transmission, color & trim information, 245 pages . . . . . BK52403 24.95
- 64-73 **Catalog Of Mustang ID Numbers 1964 1/2-1993**, codes for VIN tags, body plates, engine & transmission, color & trim information, 292 pages . . . . . BK52410 24.95
- 55-93 **Catalog Of Thunderbird ID Numbers 1955-1993**, codes for VIN tags, body plates, engine & transmission, also color & trim information, 283 pages . . . . . BK52414 24.9570-

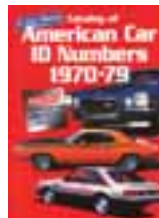

- 79 **Catalog Of American Car ID Numbers 1970-1979**, codes for VIN tags, body plates, engine & transmission, also color & trim information, 556 pages . . . . . BK38518 24.95
- 53-93 **Catalog Of Corvette ID Numbers**, helpful aid in decoding VIN tags, body plates, engine numbers, or paint & trim codes, 214 pages plus a 41 page paint color section, 282 illustrations . . . BK52408 20.95





**General Interest Books**



56-56 **Ford Accessories-passenger Car & Truck**, these 47 pages contain more than 75 photos . . . . . BK1AC56 12.95



55-70 **Thunderbird Illustrated I.D. Decoder Manual**, contains 59 pages . . . . . BK2DM55 7.95

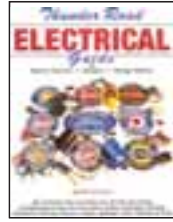

ALL **Thunder Road Electrical Guide**, a basic introductory guide to auto electrical (no technical information or service specifications for particular makes or models), with 137 pages of black & white photos, charts, illustrations & instructions . . . . . BK475D 28.95

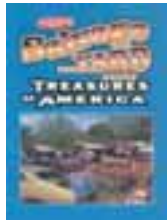

ALL **American Salvage Yard Treasures, 3rd Edition**, tour 25 western US salvage yards or browse from the extensive directory inside, 167 page photo-journal . . . . . BK52409 19.95

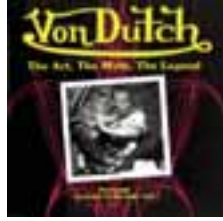

ALL **Von Dutch The Art, The Myth, The Legend**, by Pat Ganahl, known as the father of pinstriping, his legend has grown to gargantuan proportions, the author uses stories & quotes from interviews to tell the tale of a man who went from obscurity to pinstriping master & eventually back into obscurity, 192 pages with 100 color & 200 black & white photos. . . . . BK1701 39.95

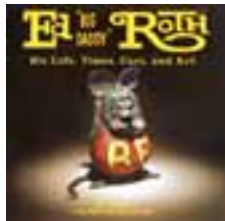

ALL **Ed "Big Daddy" Roth His Life, Times, Cars & Art**, by Pat Ganahl, to say Ed Roth was interesting is an understatement & this book covers it all, from art to custom cars, monster shirts to VW-powered trikes, pinstriping to plastic models & the wild life that brought it all together, 192 pages with 100 color & 150 black & white photos . . . . . BK1707 39.95



ALL **Deuce: 75 years Of The '32 Ford**, by Robert Genat, enjoy the complete history of Ford's landmark car, includes information on how the Deuce was built & then later hot rodded, hardbound,



192 pages . . . . . VBZ 14.50  
ALL **Antique Auto Body Accessories For The Restorer**, depicts every significant optional equipment of the era, 128 pages . . . . . CA 14.50

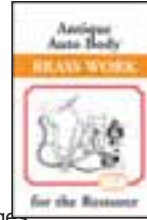

ALL **Antique Auto Body Brass Work For The Restorer**, authentic lamp, horn & instrument source book, from early catalogs, 128 pages. . . . . CB 14.50



ALL **Antique Auto Body Decoration For The Restorer**, authentic ornamental painting practices & expert instructions, 128 pages. . . . . CD 14.50

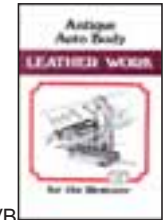

ALL **Antique Auto Body Leather Work For The Restorer**, authentic leather upholstery & trimming practice in great detail, 128 pages . . . . . CL 14.50

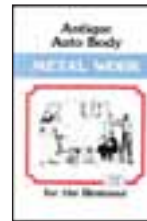

ALL **Antique Auto Body Metal Work For The Restorer**, authentic layout of steel & aluminum patterns for body panels, 128 pages . . . . . CM 14.50

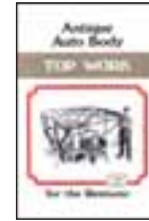

ALL **Antique Auto Body Top Work For The Restorer**, design, layout & fabrication of various tops for Phaeton car tops, 128 pages . . . . . CT 14.50

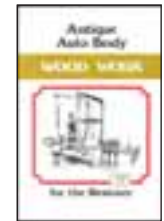

ALL **Antique Auto Body Wood Work For The Restorer**, authentic framing practices & options for open & closed cars, 128 pages. . . . . CW 14.50



ALL **Essentials Of Upholstery & Trim For Vintage & Classic Car**, for apprentice trimmers, 176 pages, 110 illustrations . . . . . UL 14.50



ALL **Auto Radiator Construction & Restoration For Antique Cars**, repair techniques, 192 pages, 125 illustrations. . . . . RD 12.75



## Automatic Transmission Lock



55-57 Automatic transmission lock, attaches to shifter & locks it in park, lock is removed when not in use, comes with 2 keys. . . . . ATL-1 30.95

## Special Tools



55-57 Dash bezel tool, specially designed for easy removal of retaining nuts for ignition, headlights, windshield wiper & heater control switches. . . . . 17470-N 7.95

ALL Headliner installation tool, our standard model. . . . . TOOL-7672 10.95



ALL Headliner installation tool, this is the deluxe model with a nice wooden handle. . . . . TOOL-13575 22.95

ALL Inside door handle & window crank removal tool for "C" clip. . . . . TOOL-22600 6.95

## Dummy Spotlight



ALL Dummy spotlight, nonfunctional, accurate reproduction of an original aftermarket accessory, chrome plated steel housing with chrome plated zinc die-cast arm & 2 brackets, mounts are included for both the left side & the right side of the car. . . . . A9A-15200 39.95

## Hood Accessory Light

*This is a reproduction of the popular Ford accessory from the '60s. It can be mounted on the underside of the hood or the trunk lid. Raising the hood or trunk activates a mercury switch, providing illumination. It's a snap to install, so order yours now!*



ALL Accessory light, includes housing, wiring & the bulb. . . . . C2RZ-15A700-A 19.95

## Battery Mat

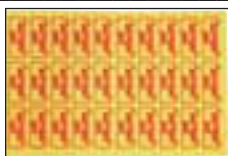

ALL Battery mat, absorbs & neutralizes battery acid & vapors, great protective accessory, 8" x 12", trim to fit. . . . . BATMAT 5.95

Prevents corrosion & helps improve battery efficiency.



ALL Corrosion arrestors, pair. . . . . C1AZ-10A717-B 2.95 pair

## Battery Disconnect Switches

*Attach to the battery post & when you leave the car, unscrew the knob. The 16 amp bypass fuse maintains current to all circuits, but because the starter needs 150 amps, the fuse will blow if someone attempts to start the car.*

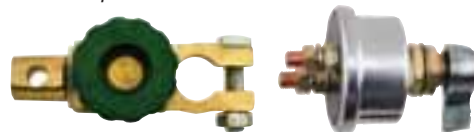

ALL Mounts on battery. . . . . A14300C 12.85  
ALL Mounts on frame. . . . . A14300D 24.75

## Power Inverter

*Power inverters convert a circuit of 6, 8 or 12 volt positive ground system to 12 volt negative ground to allow operation of 12 volt negative ground accessories, such as: car stereos, citizens band radios & cellular phones. It is a 1-3/4" cube. There is a 1 year factory warranty.*



1955 Positive ground electrical systems only, instructions are included, 2.1 amps. . . . . A10700AH 99.50

## Key Blanks & Key Fobs



55-64 Anniversary key blank, gold with red, white & blue Ford crest. . . . . BA-3685-ANV 7.95  
55-64 Key blank, single side, ignition. . . . . BA-3685-A 3.95  
55-64 Key blank, single side, trunk. . . . . BA-3685-B 3.95



65-66 Key blank, double-sided ignition. . . . . C7AZ-3685-A 2.95  
65-66 Key blank, double-sided trunk. . . . . C7AZ-3685-B 2.95  
65-66 Key blank, N.O.S. with Thunderbird logo, ignition. . . . . C5SZ-3685-A 3.95  
65-66 Key blank, N.O.S. with Thunderbird logo, trunk (not shown). . . . . C5SZ-3685-B 3.95



ALL Key fob, black leather with porcelain Ford script emblem. . . . . FORD/FOB 5.00  
ALL **NEW** Chrome key fob, with chrome Ford script on a blue background. . . . . KC-1 4.95



**License Plate Frames**

These frames have a sparkling chrome frame with white lettering over a black background. Sold Individually.



1955	"1955 Thunderbird"	B5S-18240-A	7.95
1956	"1956 Thunderbird"	B6S-18240-A	7.95
1957	"1957 Thunderbird"	B7S-18240-A	7.95



1958	"1958 Thunderbird"	B8S-18240	9.95
1959	"1959 Thunderbird"	B9S-18240	8.95
1960	"1960 Thunderbird"	COSZ-18240	8.95
1961	"1961 Thunderbird"	C1SZ-18240	8.95
1962	"1962 Thunderbird"	C2SZ-18240	8.95
1963	"1963 Thunderbird"	C3SZ-18240	8.95
1964	"1964 Thunderbird"	C4SZ-18240	8.95
1965	"1965 Thunderbird"	C5SZ-18240	8.95
1966	"1966 Thunderbird"	C6SZ-18240	8.95

**Vanity License Plate**



ALL	"Thunderbird" black background with white & teal insignia	LP46	6.95
-----	-----------------------------------------------------------	------	------

**Magnetic Show Signs**



ALL	"DANGER HIGH VOLTAGE BODY (75,000 VOLTS OF PROTECTION)"	MM1	0.95
ALL	"LOOK BUT...PLEASE DON'T TOUCH!"	MM2	3.95
ALL	"LOOK & ENJOY...BUT PLEASE DON'T TOUCH!"	MM3	3.95

**Reflector License Plate Bolts & Wing Nuts**



ALL	Blue reflector	A13409MBRB	1.25 pair
ALL	Green reflector	A13409MBRG	1.25 pair
ALL	Red reflector	A13409MBRR	1.25 pair
ALL	Yellow reflector	A13409MBRY	1.25 pair

**Car Show Supplies**

We at MAC's know that once your car is built, you want top quality products to keep it looking shiny & new. All of our car show supplies are easy to use & produce superior results. Nothing is better or faster for removing dust from your car than our Wood Duster. Our Plastic Duster does the same top notch job on interior surfaces. Simichrome has a worldwide reputation for being THE polish to use. Whether it's for a cruise night or a judged competition, look to MAC's for all of your car supplies.



ALL	The original California Water Blade® dries your car in 1/3 the time! The super soft medical grade silicone blade will never scratch your paint.	WATER-BLADE	19.75
-----	-------------------------------------------------------------------------------------------------------------------------------------------------	-------------	-------



ALL	The original California Car Duster® with a wooden handle is just the ticket to keeping your baby car show clean, special baked-on wax treated cotton fiber strands "lift" dust without scratching paint, the dirtier it gets, the better it works!	WOOD-DUSTER	18.95
-----	----------------------------------------------------------------------------------------------------------------------------------------------------------------------------------------------------------------------------------------------------	-------------	-------



ALL	The original California Mini-Duster®, the car duster's little brother—it boasts the same baked-on wax treated cotton fiber strands that "lift" dust in one easy pass	PLASTIC-DUSTER	9.00
-----	----------------------------------------------------------------------------------------------------------------------------------------------------------------------	----------------	------



ALL	Simichrome polish, for brass, chrome, nickel & stainless steel, 1.76 oz. tube	POLISH	6.75
-----	-------------------------------------------------------------------------------	--------	------





**Car Covers**

We understand how much time & money goes into making your Ford or Mercury look its best. So why buy a one-size-fits-all cover that doesn't REALLY fit anything? To better protect your investment from the elements we offer custom-fit covers, specifically made for your year & body style. With a choice of Poly-Cotton, Tan Flannel or Technalon-2 you can get the one best suited for your storage facility & your budget. Custom car covers & logo car covers are not returnable.

**Poly-Cotton**

**GOOD: This cover is best for protecting cars for a short time in a slightly protected area.**

This is a durable blend of polyester for sun & water resistance & cotton to assure a soft touch to any paint finish. Available in gray. If you don't see your car listed, please order CC-CUSTOM-PD & we will make it exactly for your vehicle. 90 day warranty.

1955	Poly-Cotton car cover	CC34596PD	179.95
1956	Poly-Cotton car cover	CC33339PD	179.95
1957	Poly-Cotton car cover	CC33935PD	179.95
1958	Poly-Cotton car cover	CC33476PD	214.95
1959	Poly-Cotton car cover	CC33476PD	214.95
1960	Poly-Cotton car cover	CC33476PD	214.95
1961	Poly-Cotton car cover	CC33359PD	214.95
1962	Poly-Cotton car cover	CC33359PD	214.95
1963	Poly-Cotton car cover	CC33359PD	214.95
1964	Poly-Cotton car cover	CC33359PD	214.95
1965	Poly-Cotton car cover	CC33359PD	214.95
1966	Poly-Cotton car cover	CC33359PD	214.95
ALL	Personalize your cover with one of the logos pictured on page 115, specify logo number when ordering	CCLOGO	25.00

**TAN FLANNEL**

**BETTER: This cover is best for cars in a protected area, such as a garage.**

This is our paint-friendly cover for the true automotive enthusiast. This poly-cotton blend fabric has a soft, napped underside with a breathable, water-resistant outer layer. Available in tan. If you don't see your car listed, please order CC-CUSTOM-TF & we will make it exactly for your vehicle. 90 day warranty.

1955	Tan Flannel car cover	CC34596TF	219.95
1956	Tan Flannel car cover	CC33339TF	219.95
1957	Tan Flannel car cover	CC33935TF	219.95
1958	Tan Flannel car cover	CC33476TF	269.95
1959	Tan Flannel car cover	CC33476TF	269.95
1960	Tan Flannel car cover	CC33476TF	269.95
1961	Tan Flannel car cover	CC33359TF	269.95
1962	Tan Flannel car cover	CC33359TF	269.95
1963	Tan Flannel car cover	CC33359TF	269.95
1964	Tan Flannel car cover	CC33359TF	269.95
1965	Tan Flannel car cover	CC33359TF	269.95
1966	Tan Flannel car cover	CC33359TF	269.95
ALL	Personalize your cover with one of the logos pictured on page 115, specify logo number when ordering	CCLOGO	25.00

**\* Warranty is for defects in material & workmanship & against the fabric becoming unserviceable. We will repair or replace after factory inspection.**

**Technalon-2**

**BEST: This cover is best for protecting cars stored outside with no other protection.**

Made of Evolution 4 fabric from Kimberly-Clark, Technalon-2 covers offer 4-layer construction for maximum protection. This unique fabric has many features. Available in gray. If you don't see your car listed, please order CC-CUSTOM-GK & we will make it exactly for your vehicle. 4 year warranty.

1955	Technalon-2 car cover	CC34596GK	209.95
1956	Technalon-2 car cover	CC33339GK	209.95
1957	Technalon-2 car cover	CC33935GK	209.95
1958	Technalon-2 car cover	CC33476GK	249.95
1959	Technalon-2 car cover	CC33476GK	249.95
1960	Technalon-2 car cover	CC33476GK	249.95
1961	Technalon-2 car cover	CC33359GK	249.95
1962	Technalon-2 car cover	CC33359GK	249.95
1963	Technalon-2 car cover	CC33359GK	249.95
1964	Technalon-2 car cover	CC33359GK	249.95
1965	Technalon-2 car cover	CC33359GK	249.95
1966	Technalon-2 car cover	CC33359GK	249.95
ALL	Personalize your cover with one of the logos pictured on page 115, specify logo number when ordering	CCLOGO	25.00

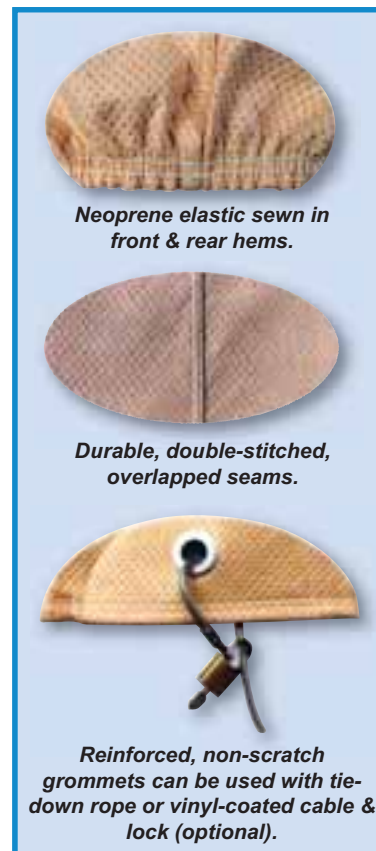

Neoprene elastic sewn in front & rear hems.

Durable, double-stitched, overlapped seams.

Reinforced, non-scratch grommets can be used with tie-down rope or vinyl-coated cable & lock (optional).

**Car Cover Material Sample Card**

Samples of both materials  
item #: SAMPLE-CARCOVER .....FREE



Car Cover Accessories

ALL Car cover lock, secure your cover so it doesn't blow off in the wind, comes complete with lock, cable & snap-together grommets . . . . . CCL-1 9.95



ALL Car cover antenna grommet, if you can't unscrew your antenna mast, you can cut a slit in your car cover & this grommet will keep the edges from fraying. . . . . CCAG-1 3.95





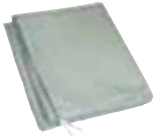



ALL Storage bag, works for any & all car covers for storage & protection. . . . . ZBAG 9.95



**Add a logo for just \$25.00! Add CCLOGO to your order & specify which logo you would like. Logo will be placed on the front radiator area. Please note, car covers with a logo are non-returnable.**



 FD-23 (12" WIDTH)	 FD-10 (8" WIDTH)	 FD-24 (8" WIDTH)
 FD-25 (6" HEIGHT)	 FD-12 (5" HEIGHT)	 FD-1 (8" HEIGHT)



**MAC's is here to help you get ready for long term or winter storage!**  
 Up here in the north, we put our toys away for the winter so they stay looking as good as possible. MAC's can provide you with all the products that will make that as easy as 1-2-3! At the top of the list is Fuel Stabilizer to keep that precious fuel from getting gummy over the winter. Next, keep that battery at full charge with our Accumate Power Charger. Also, if you want to be able to roll your prized possession around without having to get inside it, we now carry Wheel Dollies.

Fuel Stabilizer

The ideal formulation to add to the gas tank when storing vehicles for extended periods. It not only prevents varnish & tank corrosion, it has a no alcohol formula & will not attack rubber lines or diaphragms, as many other fuel stabilizers do. This is the best product on the market & our customers swear by it. Call & order yours today!

ALL One quart bottle, one ounce of this product will keep 3 gallons of fuel fresh for at least 3 years. . . . . RSP101 \* 28.95 quart



**\*Hazardous material can only be shipped by ground within the U.S. because of safety regulations.**

AccuMate® Power Charger

Nothing is worse than pulling your car out of storage & finding out your battery is dead. MAC's has a way to keep that from ever happening again, our AccuMate® Power Charger. AccuMate® is an advanced fully automatic battery charger & maintainer for all 6 & 12 volt lead-acid batteries. It will bring your battery up to a full charge & then go into standby mode. If your battery goes below a pre-determined level, the charging process is immediately restarted. Since it operates on normal 110 volt household current & only costs pennies to operate, plug it in & forget about it. From now on, your battery will always be ready.

ALL AccuMate Power Charger, 2-year factory backed warranty. . . . . 10655-TEND 64.95



Wheel Dolly Set

Have you ever wanted to push a car sideways to get it out of the way? If that car was on one of our new Auto Dolly sets, you could! Each Auto Dolly is constructed from 1/4" thick steel for extra durability & long life. The tough polyurethane casters turn on top-quality ball bearings to make for smooth rolling, even on rough surfaces. With each dolly carrying a load rating of 1500 lbs., you can move a 6000 lb. car or truck easily & safely. This is a "tool" every restorer should have, call for yours today!

ALL 4-piece set, 12" wide, red painted finish. . . . . ACC-DOLLY-12 159.95 set



Fender Covers

MAC's presents the ultimate in a fender cover, The Fender Gripper. Created to solve the problem of fender covers sliding off the car, it is made up of a non-slip, soft & pliable yet strong, PVC material. It is fully washable & impervious to motor oil, gasoline, carb cleaner & transmission, power steering & brake fluids. Its size, 22" x 34", is perfect for your fenders. The grippy surface keeps your tools in place, too! Call us today to place your order.

ALL Black, with the "Ford" oval in white (shown) . . . . . FG-FORDOVAL 19.95  
 ALL Black with "Thunderbird" & logo in white (shown) . . . . . FG-TBIRD 19.95  
 ALL **NEW** Black with original "FoMoCo" logo in white . . . . . FG-FOMOCO 19.95





## ZDDPlus Motor Oil Additive

Major oil companies have been significantly reducing the level of ZDDP (zinc) in motor oil over the past few years. This vital anti-wear ingredient is necessary in all flat-tappet classic vehicle engines. By adding one bottle of ZDDP each time you change your oil, that protection will be maintained, no matter what brand or viscosity motor oil you've been using.



ALL **NEW** Oil additive, 4 oz. bottle . . . . . ZDDPLUS 9.95

## Water Wetter

Is your engine running hot? Cool it off with Water Wetter®. Adding one 12 oz. bottle to 12–16 quarts of coolant can drop the operating temperature up to 30°. Not only that, you will also be reducing rust, corrosion & electrolysis in your cooling system. It's modern science for your classic car. Call us & place your order today!



ALL **NEW** Water Wetter®, 12 oz. bottle. WET-H2O 9.95

## Adhesives



ALL Rubber weatherstrip & felt glass channel adhesive, black, 3M brand, 5 oz. tube . . RSP28 8.75  
 ALL Weatherstrip adhesive, yellow, 3M brand, for spongy weatherstrips like what is used for the trunk, 5 oz. tube . . . . . RSP89 7.95  
 ALL Light-colored fast-drying vinyl adhesive, use as adhesive & sealer, 5 oz. tube, 3M brand . . . . . RSP31 8.50



ALL Vinyl & upholstery adhesive, 3M brand, 18.1 oz. spray can. . . . . RSP29 \* 14.75  
 ALL Super trim adhesive, 3M brand, the best adhesive for securing headliners, vinyl tops & hood insulation pads, 19 oz. spray can . . . . RSP79 \* 17.95

\* **HAZARDOUS MATERIAL** can only be shipped by ground/surface within the U.S. because of government regulations.

## Oil, Grease & Additives



ALL Wheel bearing grease, 1 pound container, Timken . . . . . GREASE 5.50  
 ALL Water pump grease, 14 oz. cartridge . . . . . GREASE/WP 5.25  
 ALL Suction gun, for changing differential oil. . . M3412 13.00



ALL Gas additive, lead substitute, 12 oz. container, treats 20 gallons, reduces valve & seat wear. . . . . LS+ 3.25  
 ALL Marvel Mystery Oil, for top of cylinders, 16 oz. container. . . . . MARVEL 3.95  
 ALL Penetrating oil, super product: we use it in our shop, 11 oz. spray can. . . . . RSP13 \* 4.95  
 ALL White grease, water resistant, use on hinges, latches, linkages & sliding parts, 12 oz. spray can . . . . . RSP19 \* 6.95



ALL Speedometer cable lubricant, graphite in oil formulated for long life, all-temperature lubrication of the speedometer cable core, 1/2 oz. . . . . A17260L 2.50

## Engine Rebuilding Supplies

Plastigage accurately measures clearance on bearing surfaces. One package is usually enough for one car.



ALL Plastigage, from 0.001" to 0.003" . . . . . PG1 1.85



ALL Plastigage, from 0.002" to 0.006" . . . . . PG2 1.85



ALL Permatex Prussian Blue, for precision fitting of valve gears, bearings & other machined surfaces, .75 oz. . . . . PG3 3.75



ALL Permatex valve grinding compound, 1.5 oz. tube . . . . . RSP26 3.90



ALL Permatex "Form-a-Gasket," silicone, replaces almost any cut gasket, 3 oz. tube . . . . . RSP50 4.95



ALL Distributor cam lubricant, 7/8 oz. tube, made with silicone . . . . A12210L 7.95



ALL Permatex anti-seize lubricant, a blend of aluminum, copper & graphite lubricants. Perfect for easy removal of spark plugs & cylinder head or exhaust manifold bolts, 1 oz. tube . . . RSP102 3.95





ALL "High Tack" by Permatex, a gasket sealant with a thousand uses, use it on your water pump, thermostat housing, valve covers, or put it directly on the threads of a gas line or brake line, its non hardening formula assures you of a leakproof seal, 4 oz. can . . . . .RSP25 \* 5.45



ALL Permatex heavy-duty radiator cleaner, 1 quart. . . . .RSP27 12.25  
 ALL Permatex gasket remover, quickly removes all types of baked-on gaskets, adhesives & sealants, 12 oz. spray can . . . . .RSP52 \* 5.95  
 ALL Belt dressing, adds to belt life, helps increase performance, 5 oz. spray can . . . . .RSP10 \* 3.95  
 ALL Carburetor cleaner, acts in seconds, great for old cars, 12.5 oz. spray can. . . . .RSP14 \* 4.95  
 ALL Battery protector, seals terminals & prevents corrosion, cuts current loss, 5 oz. spray can . . . . .RSP15 \* 3.95



ALL Electric motor cleaner, instant penetration without insulation damage, 19 oz. spray can . . . . .RSP18 \* 4.95  
 ALL Teflon tape, use it on the threads of the oil pressure & water temperature senders, 3/4" wide x 520" total length . . . . .TAPE 1.95 roll  
 ALL **NEW** Head gasket sealant, resists heat up to 525°, use on exhaust manifolds, cylinder head gaskets, carb base gaskets, 9 oz. spray can . . . . .RSP32 \* 8.15

**High Temp Silicone Gasket**

*This high-temp sealant replaces cork, rubber, silicone, felt & any other cut gaskets to form a leak-proof seal. It resists oil, grease, water, antifreeze mixture & transmission fluid. More flexible than conventional gaskets, it can be used on water pumps, exhaust manifolds, valve covers, timing gear covers, transmission pans, water neck outlets or anyplace a high-performance gasket is needed. It's perfect for emergency, side of the road, repairs.*



ALL Silicone gasket, good up to 700°, 3 oz. tube . . . . .A5251SEAL 4.95

**Glasswork**

ALL Windshield setting tool, nylon, cannot scratch or chip glass . . . . .RSP216 1.50



ALL "Hook tool," used to install windshield & back glass weather stripping. . . . .RSP253 10.95



ALL Glass silicone sealer, black, 10 oz. cartridge . . . . .RSP408BL 9.75

ALL Glass silicone sealer, clear, 10 oz. cartridge . . . . .RSP408C 9.75



ALL Quick release agent, makes removal of windshield & back glass easier by softening or dissolving the old adhesive, 14 oz. spray can . . . . .RSP958 \* 10.95



ALL Instant bond adhesive, .02 oz bottle, works on rubber & even foam. . . . . 11067-2 2.95



\* **HAZARDOUS MATERIAL** can only be shipped by ground/ surface within the U.S. because of government regulations.

**Don't Forget Strip Caulk!**

*This is the original "dum-dum" that is used in many places on a car, such as the seams in metal, like trunk floors, floorboards, the cowl/dash area & on the pillar post. Also used as a base under roof rail seals. A multi-use product that every workbench should have!*



ALL Strip caulk, 3M brand, 20 yards . . . . .8578 15.95 box

**Gas Tank Slushing Compound**

*Stops rust, leaks & corrosion permanently. Resists alcohol & all fuels including Phase II oxygenated fuels. Bonds to all metal & fiberglass gas tanks. Outsells all other sealers on the market combined. One can does several tanks.*



ALL Gas tank slushing compound/sealer, one quart can . . . . .RSP22A \* 24.25 qt.

\* **HAZARDOUS MATERIAL** can only be shipped by ground/ surface within the U.S. because of government regulations.



## Engine Compartment & Reconditioning Paint

Detailing your engine compartment is easy with our detail paints. Whether its spray cans or quarts, MAC's detail paints will make your car the star of the show!



- 55-57 Engine paint, Thunderbird Red, 12 oz. spray can . . . . . RSP81 \* 6.95
- 58-59 Engine paint, blue, 12 oz. spray can, the whole engine in 1958 but just the valve covers in 1959 . . . . . RSP99 \* 6.95
- 58-60 Engine paint, white, 12 oz. spray can, air cleaner assembly . . . . . RSP97 \* 6.95
- 59-65 Engine paint, gloss black, 12 oz. spray can, valve covers in 1958 & complete engine from 1959-1965 . . . . . RSP5 \* 6.00
- 63-65 Engine paint, gold, 12 oz. spray can, valve covers & air cleaner assembly . . RSP82 \* 10.95

When this top quality high gloss enamel is applied with a spray gun, it can give a "factory" look finish. Rated to 600° & sold in the correct shade of red, your car can be the one everybody is looking at for comparison. One quart is more than enough for one engine.

- 55-57 Engine paint, Thunderbird Red, 1 quart can . . . . . RSP92 \* 32.95 qt.
- 55-57 Turquoise touch up paint, perfect for aluminum valve covers & can also be used on the dash emblem. . . . . RSP40 \* 9.95



- 58-60 Heater box paint, black, 12 oz. spray can, for heater box under dash leaves a "wrinkle" finish . . . . . RSP100 \* 6.95
  - 1960 Engine paint, yellow, 20 oz. spray can, valve covers . . . . . RSP98 \* 8.95
  - 61-62 Engine paint, Argent (silver), 12 oz. spray can, valve covers & air cleaner, **Genuine Ford** . . . . . RSP84 \* 13.95
- Beginning in 1966 Ford painted the entire engine (block, heads, intake manifold, front cover, oil pan, valve covers & air cleaner assembly) Medium Ford Blue.
- 1966 Engine paint, Medium Ford Blue, quart can, whole engine . . . . . RSP93 \* 32.95 qt.

\* **HAZARDOUS MATERIAL** can only be shipped by ground/ surface within the U.S. because of government regulations.



- 1966 Engine paint, Medium Ford Blue, 12 oz. spray can, whole engine . . . . . RSP80 \* 6.95
- ALL Cast Blast, 12 oz. spray can, restore a new cast iron look to freshly cleaned or bead blasted parts . . . . . RSP86 \* 6.95
- ALL Alumi Blast, 12 oz. spray can restores a new aluminum look to freshly cleaned or bead blasted parts . . . . . RSP87 \* 6.95
- ALL Semi-gloss black, 12 oz. spray can, for most brackets & suspension parts. RSP85 \* 6.95
- ALL Gloss clear lacquer, 12 oz. spray can, use under the hood on hoses, wires & plastic to get a shiny new appearance . RSP88 \* 6.95
- ALL Cast iron gray, hi-temp, 12 oz. spray can, good up to 1200°, can be used on exhaust manifolds without fear of it burning off. . . . . RSP96 \* 8.95



- ALL Red oxide primer, 10 oz. spray can, great for small jobs . . . . . RSP1 \* 5.95
- ALL Cold galvanizing, this zinc heavy primer is THE product to use on bare metal surfaces to protect them, has weld-thru properties, 15 oz. spray can . . . . . RSP4 \* 8.95
- ALL Primer, 12 oz. spray can, green zinc phosphate for use on galvanized steel, aluminum, white metals & steel . . . . . RSP3 \* 7.95
- ALL Chrome paint, 12 oz. spray can, great for refinishing the metal reflectors of tail lights, backup lights & parking lights for increased visibility . . . . . RSP24 \* 5.95

## Polish, Cleaners & Protectants



- ALL Simichrome polish, for brass, chrome & nickel, tube, simply the best! . . . . . POLISH 6.75
- ALL Cleaner & degreaser, spray on & wash off! 13 oz. spray can . . . . . RSP11 \* 4.45
- ALL Glass cleaner, made especially for cleaning automotive windows, 16 oz. spray can RSP12 \* 4.95
- ALL Armorall cleaner, 20 oz. pump, specially formulated to remove ground-in dirt, grease, road grime, tar & brake dust. Safe for all surfaces like the dash, seat covers & carpet. . . . . RSP21 5.95



# RESTORATION SUPPLIES & TOOLS



ALL Vinyl top dressing, black, restores the shiny black look of weather-beaten tops, sold by the quart. . . . . RSP70 13.50 qt.

*MAC's tested & approved! Combine the best cleaner on the market with our awesome protectant & your top will look great & stay looking that way!*

ALL Convertible top cleaner, Raggtopp brand, 16 oz. pump. . . . . RSP21438 11.95

ALL Convertible top protectant, for vinyl material, Raggtopp brand, 16 oz. pump. . . . . RSP11415 16.95

ALL Convertible top protectant, for fabric tops, Raggtopp brand, 14 oz. spray can. . . . . RSP21414 \* 19.95

\* **HAZARDOUS MATERIAL** can only be shipped by ground/ surface within the U.S. because of government regulations.

## Sound Deadener & Insulation

Jute backing, this is a synthetic jute, this is that material that was installed at the factory behind your kick panels, it was also behind quarter trim panels & under the carpet, or floor mat & overall it served as a sound deadener, 1/2" thick x



ALL 36" W x 72" L . . . . . B13000 15.95

*For years, we have been selling the original Dynamat & can boast of hundreds of satisfied customers. We are now proud to offer the next generation of Dynamat sound deadeners, Xtreme. Xtreme is a step up from the original formula & is Dynamat's best product at controlling vibration. It damps 4 times as much as the original Dynamat & as an added bonus, it weighs 50% less. It is available in conveniently sized 18" x 32" sheets & with peel & stick application; it goes on quickly & easily. Do yourself a favor & order some today!*



ALL Dynamat Xtreme, each piece is 18" x 32" (as required) . . . . . DYNAMAT-0433 29.95



ALL Insulation sheet, a well-insulated firewall, transmission tunnel & floor pans are a must for any restoration or street rod, the V700770X insulation sheet with a space-age reflective foil bonded on both sides & rated R18.3 (700° F heat resistance), can also be used in kick panels, inside door panels & under carpeting, 48" x 72" x 5/16" thick . . . V700770X 32.00



ALL Insulation sheeting, tar-coated sound deadener, 3' wide x 8' long x 1/16" thick, plastic. . . V5010F 7.75

## Tools



ALL Stud extractor, for those rusted-in, corroded, hard to remove exhaust studs. . . . . X6065 38.75



ALL Piston ring compressor, can be used on 2-1/8", up to a 5" bore . . . . . X6151 11.95



51-59 Inside door handle "C" clip tool, slip it in between the handle & the door panel & its special design will release the "C" clip. . . . . TOOL-22600 6.95



ALL Windshield setting tool, nylon, cannot scratch or chip glass. . . . . RSP216 1.50



ALL "Hook tool," used to install windshield & back glass weather stripping. . . . . RSP253 10.95



ALL Light bulb pliers, a convenient tool for removing various sizes of round socket type bulbs . . . . . TOOL-BULB 22.50



ALL Suction gun, incredibly useful for removing old fluids from transmissions, differentials & other places that are normally difficult to drain . . . . . M3412 13.00



ALL Hog-ring pliers, professional quality pliers with comfortable vinyl covered handles, they make attaching seat covers to the seat frame much easier . . . . . T4407U 25.25



ALL **NEW** Universal bearing grease packer kit, applies fresh grease evenly to virtually any bearing. The old grease is forced out onto the cone for easy clean up, 4-1/2" diameter cone . . . . . X6150 9.50 kit



ALL **NEW** Universal seal puller, use on any oil or grease seal. Place the tip behind the seal, press & pull, two tip sizes fit almost all applications. . . . . X1175 9.50



ALL Headliner installation tool, economy version. . . . . TOOL-7672 10.95



ALL Headliner installation tool, wood handle, "pro" version. . . . . TOOL-13575 22.95





# STOP RUST PERMANENTLY!



These products are designed to work as a complete system. When used together, these products provide a coating that will not only stop rust, but will prevent it from returning.

## Here's How it Works...

### Step 1—Degrease & Clean

Marine Clean™ degreaser/cleaner will remove dirt, grease, wax & other contaminants that could interfere with the restoration. Before you apply ANY rust preventive paint or coating, you MUST remove any oily film or residue!

### Step 2—Neutralize Rust

METAL READY™ provides the best adhesion on any surface including aluminum & shiny polished metal surfaces. While neutralizing rust, it etches metal, creating an ideal anchor pattern for coatings such as POR-15®, while leaving a zinc phosphate film to promote chemical bonding of paint & steel.

### Step 3—Stop Rust Permanently

POR-15® is designed to be coated right onto rusty surfaces. It leaves a beautiful, rock-hard finish that won't crack, chip or peel & stops rust PERMANENTLY! The secret is in its nonporous surface. It doesn't let moisture reach the surface of the painted metal, so no rust can form. POR-15® is also flexible, so it can withstand twisting without cracking, but it has a tougher finish than ordinary paint, so it can survive what no paint can.



**Paint  
Right  
Over  
Rust!**



Auto | Farm | Marine | Industrial | Home

*All POR-15 products are considered hazardous material & can only be shipped by ground /surface within the U.S. because of government regulations.*

Step #	Description	Item #	Price
Step 1	Marine Clean, 1 gallon	POR-403	20.95 gallon
Step 2	Metal-Ready, quart	POR-407	16.95 quart
Step 3	POR-15, Gloss black, quart	POR-105	44.95 quart
Step 3	POR-15, Semi-gloss black, quart	POR-101	44.95 quart
Step 3	POR-15, Silver, quart	POR-103	44.95 quart
—	Starter kit, Gloss black	POR-506	19.95 kit
—	Starter kit, Silver	POR-508	19.95 kit
—	Starter kit, Semi-gloss black	POR-510	19.95 kit
—	Solvent	POR-402	11.95 quart

### Still Skeptical?

Try one of our **Super Starter Kits** for only \$19.95. They include everything you'll need to test out these incredible products. Each kit contains: One half pint of MARINE CLEAN™, one half pint of METAL-READY™, a 4 oz. can of POR-15®, two wooden handle paint brushes & a pair of special high dexterity surgical latex gloves.

### POR-15 Solvent

No more hard cleanup! This solvent is specially formulated by the makers of the entire POR line to make for easy cleanup or thinning of POR-15®.



**Always wear gloves when working with these products!**



### Topcoats



These topcoats are specially formulated to work with POR-15®. They are non-UV sensitive, highly flexible, nonporous & extremely scratch & chip resistant, just like POR-15®.

**CHASSIS COAT BLACK™** top coat dries to a satiny semi-gloss that is correct for most 1950s & newer car & truck frame & suspension pieces.

**BLACKCOTE™** top coat is the glossy black used on car or truck frame & suspension pieces in the early fifties & before.

**METAL MASK™** top coat is a super tough coating that looks just like bare metal. Now you can protect your steering box, spindle, leaf springs, coil springs, master cylinder & anything that requires a bare metal finish.

### Primer



If you choose to use a non POR topcoat over your POR-15®, it is recommended that you first apply **TIE-COAT PRIMER™**. No need to rough up or de-gloss the POR-15® surface. Apply the TIE-COAT PRIMER™ & you are ready for the paint of your choice.

### Vinyl Protectant

#### Lasts for Months, not Days!



POR-15® has developed a vinyl protectant that outperforms all the rest, **BOSS GLOSS™**. The key to the difference is a greater percentage of solids in this formula. They make it work better & last longer than those popular national brands. You'll only have to use this product once to see the difference.

### Seam Sealer



This is the ultimate filler & seam sealer! **POR-PATCH™** is a highly concentrated paste form of POR-15, available in a tube. It dries hard as a rock, but remarkably remains flexible. Once dry it is totally impervious to fuels & solvents. With its applicator tube & thick consistency, it's perfect for seams & holes. Its incredible formula allows you to bond steel to plastic, wood or concrete!

### High Temperature Topcoats

We carry high-tech coatings that can withstand high temperatures from 1200° to 1400° F. They resist cracking, chipping & peeling & won't burn off. They can be brushed or sprayed on.

#### No Burning or Discoloration



### Steering Wheel Restoration

You can bring that cracked steering wheel back to its original beauty with our new POR-15® Steering Wheel Restoration Kit. We give you everything you need to get the job done.

Each kit includes the following:

- Marine Clean Spray Cleaner
- Contoured Sanding Block
- Red Scuff Pad (360–400 grade)
- High Gloss Polishing Compound
- Polyester Primer & Surfacer With Hardener
- Spray Bottle/Cartridge for Primer & Enamel
- Gray (600–800) Scuff Pad Sandpaper
- Detailed, Illustrated Instruction Book
- Steering Wheel Sanding Board
- POR Epoxy Putty
- Surgical Latex Gloves
- Saw, File & Drill Bit
- Tack Cloth

**A Must for Restorers**



Description	Item #	Price
Chassis Coat Black	POR-201	48.95 quart
Black Cote	POR-203	48.95 quart
Metal Mask	POR-206	48.95 quart
Black Velvet- 1200°	POR-306	30.95 pint
Factory Manifold Gray- 1400°	POR-304	30.95 pint
POR-20- 1400°	POR-302	32.95 pint
Tie-Coat Primer	POR-601	29.95 quart
POR-Patch—black	POR-701	17.95 4 oz. tube
POR-Patch—white	POR-702	17.95 4 oz. tube
Boss Gloss	POR-801	17.95 8 oz. bottle
Steering Wheel Kit	POR-901	91.95 kit





Let MAC's take you back with these retro cruise items. Whether it's for your classic ride, or the one parked next to it, these timeless toys will liven up your next '50s night out.



### Wolf Whistle

*"Imitates the Famous Sexy Whistle!"*

This "Blast From The Past" produces the "famous" wolf call that never fails to attract attention. Simply attach it to a source of vacuum & you are on your way to laughs from your friends & catcalls from your "new" acquaintances.

- All Metal
- Hi-grade Die Casting
- Hammer Tone Finish

**Great for Cruise Night!**

WOLF ..... 49.75



### Novelty Mug

*"Stromberg 97 Mug"*

It's a ceramic replica of the famous Stromberg 97 carburetor. The originals leaked but ours won't! Put pencils in it, use it as a vase, heck, you can even drink from it! A great conversation piece for your desk.

MUG97 ..... 13.95



7213-SKULL-CC

### Shift Knobs

*"Make your stick real slick."*

That old time "Three On The Tree" or the racers "Four On The Floor" needs a new look—check out these shift knobs & give your car a custom look.

- 7213-8BALL ..... 10.95
- 7213-SKULL-CC ..... 18.95
- 7213-PISTON ..... 10.95
- NEW** A7213CHB ..... 6.45
- NEW** A7213DBLK ..... 10.50
- NEW** A7213DBLU ..... 10.50
- NEW** A7213DRED ..... 10.50



7213-8BALL



A7213CHB



7213-PISTON

- A7213DBLK
- A7213DBLU
- A7213DRED

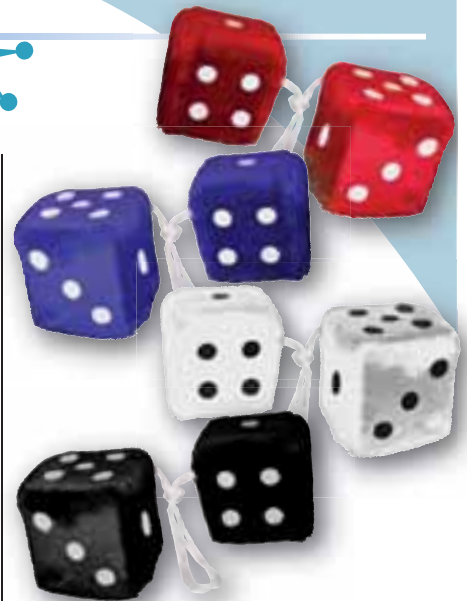

### Classic Fuzzy Dice

*"For your rear-view mirror!"*

With your choice of 4 colors in a big 3" square, these fuzzy dice look great & are priced right.

- DICE33-BLK ..... 4.95
- DICE33-BLU ..... 4.95
- DICE33-RED ..... 4.95
- DICE33-WHT ..... 4.95



**Right out of the '50s!**

### Custom Steering Knob

*"Insert ANY Picture!"*

Everybody knows that this is not to be used for anything other than a decoration, but what a decoration it is! The front opens up so you can add any photo you desire.

3600-PHOTO ..... 6.95





### Valve Stem Caps

Dress up your old wheels with some nostalgic valve stem caps. We have dice in 7 colors plus chrome or check out our famous 8 ball. You can even scare kids with skulls on every wheel. Whatever your choice, you're making a statement.

8 ball (set of 4) . . . . .	1017-8BALL-BLK	4.95
Piston (set of 4) . . . . .	1017-PISTON-CC	9.95
Skull (pair) . . . . .	1017-SKULL	9.95
Dice (set of 4)		
Chrome . . . . .	1017-DICE-CC	4.95
Black . . . . .	1017-DICE-BLK	3.95
Blue . . . . .	1017-DICE-BLU	3.95
Brown . . . . .	1017-DICE-BRN	3.95
Green . . . . .	1017-DICE-GRN	3.95
Red . . . . .	1017-DICE-RED	3.95
Purple . . . . .	1017-DICE-PRP	3.95
White . . . . .	1017-DICE-WHT	3.95



### Door Lock Knobs

Have a little fun with your interior. Add some of our colorful door lock knobs. Choose from dice, an 8-ball, a piston or the always scary chrome skull! Sold in pairs.

8 ball . . . . .	21850-8BALL	4.95
Piston . . . . .	21850-PISTON-CC	4.95
Skull . . . . .	21850-SKULL	13.95
Dice		
Chrome . . . . .	21850-DICE-CC	4.95
Brown . . . . .	21850-DICE-BRN	4.95
Green . . . . .	21850-DICE-GRN	4.95
Purple . . . . .	21850-DICE-PRP	4.95
White . . . . .	21850-DICE-WHT	4.95
Red . . . . .	21850-DICE-RED	4.95
Black . . . . .	21850-DICE-BLK	4.95
Blue . . . . .	21850-DICE-BLU	4.95

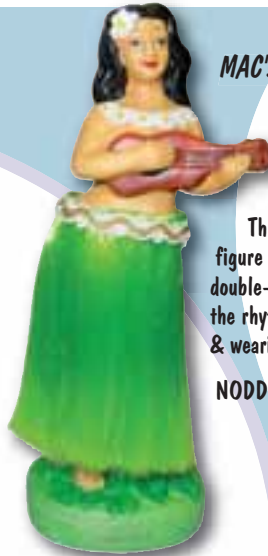

NODDER-HULAGIRL

### Nodders

MAC's has a great assortment of nodders & toppers. Spice up your next ride or cruise night by adding one of our friends to the interior or exterior of your car.

#### Hula Girl—7½"

This attractive 7-1/2" tall ceramic Hula figure attaches to the dashboard of your car with double-sided foam tape—her hips swaying to the rhythm of the road. She's playing a ukulele & wearing a bright flowing skirt.

NODDER-HULAGIRL . . . . . 9.95



NODDER-HULAGIRL2

#### Hula Girl 2—5¼"

Here's an affordable, hard vinyl version of our swaying Hula Girl. She stands 5-1/4" tall, with a flowing "grass" skirt & spring action hips. Double-sided foam tape is included for attachment to your dashboard.

NODDER-HULAGIRL2 . . . . . 5.95

### Antenna Toppers

The "hottest" antenna toppers around! Durable, plastic construction, rubber inserts & wind resistant vinyl flames make these guys look great on any classic ride. Our Tiki & Rat Fink even have glow-in-the-dark eyes!



Flaming Skull  
TOPPER-SKULL . . . . . 4.95

Mister Horsepower  
TOPPER-MRHP . . . . . 4.95



Flaming Rat Fink  
TOPPER-RATFINK . . . 4.95



Flaming Devil  
TOPPER-DEVIL . . . . . 4.95



Flaming Eightball  
TOPPER-8BALL . . . . . 4.95



Flaming Eyeball  
TOPPER-EYEBALL . . . 4.95



**Ford Decals**

ALL	"Ford" adhesive oval decal/ white letters on a blue background 3-1/2" x 1-1/2" . . . . .	DF361	3.00
ALL	Same as above, <b>except</b> 6-1/2" x 3" . . . . .	DF362	3.75
ALL	Same as above, <b>except</b> 9-1/2" x 4-1/2" . . . . .	DF363	4.25
ALL	Same as above, <b>except</b> 17" x 7-3/4" . . . . .	DF364	5.05
ALL	"Ford" oval decal/ blue letters on a clear background, 17" . . . . .	DF1391	5.95
ALL	"Genuine Ford Parts" decal/ 3" x 3-1/8" . . . . .	DF531	3.00



DF361  
DF362  
DF363  
DF364  
DF1391



DF531

**Ford Hat Pins**

*Hat Pins are enameled metal & come with a backing fastener. Only the years listed are available.*



Item # . . . .	Year	Item # . . . .	Year	Item # . . . .	Year	Item # . . . .	Year
HP-1 . . . . .	PLAIN	FHP-35 . . . .	1935	FHP-53 . . . .	1953	FHP-67 . . . .	1967
HP-T . . . . .	"T"	FHP-36 . . . .	1936	FHP-54 . . . .	1954	FHP-68 . . . .	1968
HP-A . . . . .	"A"	FHP-37 . . . .	1937	FHP-55 . . . .	1955	FHP-69 . . . .	1969
FHP-23 . . . .	1923	FHP-38 . . . .	1938	FHP-56 . . . .	1956	FHP-70 . . . .	1970
FHP-24 . . . .	1924	FHP-39 . . . .	1939	FHP-57 . . . .	1957	FHP-71 . . . .	1971
FHP-26 . . . .	1926	FHP-40 . . . .	1940	FHP-58 . . . .	1958	FHP-72 . . . .	1972
FHP-27 . . . .	1927	FHP-41 . . . .	1941	FHP-59 . . . .	1959	FHP-73 . . . .	1973
FHP-28 . . . .	1928	FHP-46 . . . .	1946	FHP-60 . . . .	1960	FHP-74 . . . .	1974
FHP-29 . . . .	1929	FHP-47 . . . .	1947	FHP-61 . . . .	1961	FHP-75 . . . .	1975
FHP-30 . . . .	1930	FHP-48 . . . .	1948	FHP-62 . . . .	1962	FHP-76 . . . .	1976
FHP-31 . . . .	1931	FHP-49 . . . .	1949	FHP-63 . . . .	1963	FHP-77 . . . .	1977
FHP-32 . . . .	1932	FHP-50 . . . .	1950	FHP-64 . . . .	1964	FHP-78 . . . .	1978
FHP-33 . . . .	1933	FHP-51 . . . .	1951	FHP-65 . . . .	1965	FHP-79 . . . .	1979
FHP-34 . . . .	1934	FHP-52 . . . .	1952	FHP-66 . . . .	1966		

**Oval with specified year.**

*We carry all years from 1923 thru 1979 except 1925 & the war years 1942-1945. . . . .*

**\$4.95**





**Miscellaneous Hat Pins**



HP-7



HP-4



HP-27



HP-5



HP-18



HP-19



HP-26



HP-3



HP-2

**Mustang & Thunderbird Hat Pins**

Item#	Year
MHP-64	1964
MHP-65	1965
MHP-66	1966
MHP-67	1967
MHP-68	1968
MHP-69	1969
MHP-70	1970
MHP-71	1971
MHP-72	1972
MHP-73	1973



MHP-64



MHP-73



HP-21



HP-20



MHP-69



HP-23



HP-22

**Truck & V-8 Hat Pins**



HP-30



HP-13



HP-14



HP-11



HP-29

**Nameplate Hat Pins**



HP-12

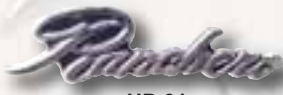

HP-31



HP-9

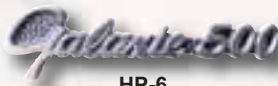

HP-6

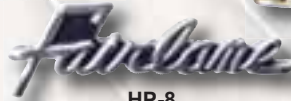

HP-8

**Mercury Hat Pins**

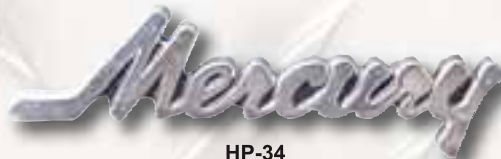

HP-34



HP-32



HP-33

**\$4.95**  
each

Refer to part number when ordering





# Pedal Cars

**1 2 05** All pedal cars are oversized & require additional handling

**\$239<sup>95</sup>**

## Flamin' Hot Rod

- Chrome steering wheel & grille
- All steel body
- Flame decals on sides
- Ages 3-5 years



PEDAL-32-FLAMES

**\$264<sup>95</sup>**

## Mustang

- Chrome steering wheel & windshield frame
- All steel body
- Choose from 2 colors
- Ages 3-5 years



PEDAL-MUSTANG-BLUE

PEDAL-MUSTANG-RED

## The "Sporty"

- Chrome steering wheel
- All steel Body
- 2 position seat
- 3 position pedals
- Ages 3-7 years

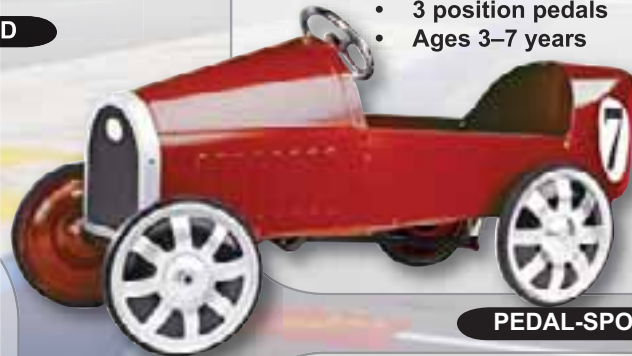

PEDAL-SPORTY

**Kids Love 'Em!**

## Yellow Roadster

- Chrome steering wheel & windshield frame
- Heavy gauge steel body
- Simulated fold back top
- Powder-coated lead free paint
- Adjustable Pedals



PEDAL-YELLOW

**\$199<sup>95</sup>**

## Jalopy Pick-Up Truck

- Chrome steering wheel & windshield frame
- Hardwood frame
- 3 position pedals
- Working tailgate



PEDAL-PICKUP



**Jalopy Sedan**

- Chrome steering wheels, windshield bars, radiators & head lights
- Heavy gauge steel body
- Wooden dashes
- Custom graphics
- Simulated gauges
- Powder coated lead-free paint
- Ages 3-5 years old
- \*Some assembly required

**\$159<sup>95</sup>**



**PEDAL-GREEN**

**PEDAL-PINK**

**PEDAL-RED**

**Gas Pumps**

- Heavy-duty steel bodies
- 32" tall
- Opening doors
- Can be used for CD storage
- Ringing bells
- Plastic hoses

**\$119<sup>95</sup>**



**PUMP-BLACK**

**PUMP-GREEN**

**PUMP-RED**

**Scout-A-Longs**

**\$79<sup>95</sup>**

**Scout-A-Long Fire Truck**

- Heavy gauge steel body
- Plastic fenders protect wall & furniture
- Chrome fire bell & Ladder racks
- Wooden Ladders
- Custom graphics
- Toy safety tested & approved
- Chip & rust resistant, child safe, non-toxic. powder coating paint
- Ages 1-3 years old
- Maximum recommended weight 42 lbs
- \*Some assembly required

**Scout-A-Long Freestyle**

- Heavy gauge steel body
- Plastic fenders protect wall & furniture
- Steel wheels with rubber tires
- Working steering wheel
- Custom graphics
- Toy safety tested & approved
- Chip & rust resistant, child safe, non-toxic powder coating paint
- Ages 1-3 years old
- Maximum recommended weight 42 lbs
- \*Some assembly required

**Scout-A-Long Speedster**

- Heavy gauge steel body
- Plastic fenders protect wall & furniture
- Steel wheels with rubber tires
- Working steering wheel
- Custom graphics
- Toy safety tested & approved
- Chip & rust resistant, child safe, non-toxic powder coating paint
- Ages 1-3 years old
- Maximum recommended weight 42 lbs
- \*Some assembly required



**SCOOT-FLAMES**



**SCOOT-PINK**



**SCOOT-FIRETRUCK**





# Mac Wear

The latest additions to our t-shirt collection celebrate some of the earliest Fords, the Model T, Model A & the V-8. These all have the MAC's logo on the front with a beautiful full color print on the back. These are hand drawn designs exclusive to MAC's.

**Front View**



Small thru X-Large = \$9.00  
XX-Large = \$10.00

**Back Views**

- Item #  
T-SHIRT-S  
T-SHIRT-M  
T-SHIRT-L  
T-SHIRT-X  
T-SHIRT-XX



- Item #  
A-SHIRT-S  
A-SHIRT-M  
A-SHIRT-L  
A-SHIRT-X  
A-SHIRT-XX



- Item #  
V-SHIRT-S  
V-SHIRT-M  
V-SHIRT-L  
V-SHIRT-X  
V-SHIRT-XX



**M-SHIRT & MSW-SHIRT have the same back print**

- Item #  
M-SHIRT-S  
M-SHIRT-M  
M-SHIRT-L  
M-SHIRT-X  
M-SHIRT-XX



T-Shirts  
Small thru X-Large = \$10<sup>25</sup>  
XX-Large = \$11<sup>25</sup>

- Item #  
MSW-SHIRT-S  
MSW-SHIRT-M  
MSW-SHIRT-L  
MSW-SHIRT-X  
MSW-SHIRT-XX

**Back View**



Sweatshirts  
Small thru X-Large = \$20.00  
XX-Large = \$24<sup>95</sup>





Now THAT'S COOL!



Available in 3 cool flavors!

# RETRO



This nostalgic Model A HiBoy roadster has wires, radius rods & a full-dress flathead with all the goodies. Black print on ash gray.

- Item #
- NSA-SHIRT-L .....\$10.00
  - NSA-SHIRT-XL .....\$10.00
  - NSA-SHIRT-XX .....\$11.00

Our shirts printed on one side & pre-shrunk.



You'll appreciate this full-fendered Deuce roadster with steelies & caps, louvered hood sides & a perfect rake. Navy Blue print on Parchment.

- Item #
- NSV-SHIRT-L .....\$10.00
  - NSV-SHIRT-XL .....\$10.00
  - NSV-SHIRT-XX .....\$11.00



Our 1950 Custom is a period perfect lowered leadsled featuring dummy spots, spinner caps & chopped top. Ivory print on black.

- Item #
- NSF-SHIRT-L .....\$10.00
  - NSF-SHIRT-XL .....\$10.00
  - NSF-SHIRT-XX .....\$11.00

## BASEBALL CAPS



- S-CAP-F
- S-CAP-E
- S-CAP-M SHOWN
- S-CAP-M
- S-CAP-T
- S-CAP-V
- S-CAP-C
- S-CAP-SR
- S-CAP-A
- S-CAP-TB
- S-CAP-MUST

Blue baseball style hats. One size fits all, adjustable. Choose one of the logos below. Logos are stitched. in white onto the hat. **\$4.95**

## OVAL CLOTH PATCHES

- PATCH-F
- PATCH-A
- PATCH-T
- PATCH-V

**\$2.50**

## DRIVER'S CAPS

### D-CAP

- D-CAP
- D-CAP-A
- D-CAP-F
- D-CAP-T
- D-CAP-V

White "Gatsby" style driving caps. One size fits all, adjustable. Order it 'as is', or with one of the patches shown above.

**without patch \$10.50**      **with patch \$12.50**



# MAC's Saves You the Shipping Charges With FREE Show Delivery!



Order from any of our 10 catalogs and we deliver it to you at the show! That's right, you can stretch your dollars and save big bucks when you order with us and pick up your parts at any event on the MAC's 2009

Show Schedule. You not only save on the shipping and freight charges, you also avoid the hassle of waiting for home delivery—plus we'd love to meet you! (Space limitations might apply; see below for details.)

## MAC's Antique Auto Parts 2009 Show Schedule

### **Cavalcade Of Cars—Hamburg, NY**

Friday, March 6—Sunday, March 8

Spaces: Main Room

Order Cutoff Date: Noon each day for delivery the next day

### **Dunkirk Flea Market—Dunkirk, NY**

Friday, May 15—Saturday, May 16

Spaces: B1–2

Order Cutoff Date: Noon on Wednesday, July 13

### **Carlisle All Ford Nationals—Carlisle, PA**

Friday, June 5—Sunday, June 7

Spaces: J163–168

Order Cutoff Date: Noon on Tuesday, June 2

### **Eastern Street Rod Nationals—York, PA**

Friday, June 5—Sunday, June 7

Spaces: 344–346

Order Cutoff Date: Noon on Tuesday, June 2

### **Syracuse Nationals—Syracuse, NY**

Friday, July 17—Sunday, July 19

Spaces: 1–3 in Main Building

Order Cutoff Date: Noon on Tuesday, July 14

### **NSRA Street Rod Nationals—Louisville, KY**

Thursday, August 6—Sunday, August 9

Spaces: 442 & 546

Order Cutoff Date: Noon on Friday, July 31

### **Fall Carlisle—Carlisle, PA**

Thursday, October 1—Saturday, October 3

Spaces: E137–142

Order Cutoff Date: Noon on Monday, September 28

### **Hershey Fall AACA—Hershey, PA**

Wednesday, October 7—Saturday, October 10

Spaces: (North Red Field)RNC35–39 & RND35–42

Order Cutoff Date: Noon on Monday, September 28

### Information on Placing Free Delivery Orders

To have your order delivered free at any of the above shows, simply call 800-777-0948 and place your order from any catalog. Let us know what show to bring it to and we will have your order there waiting for you!

- Orders must be picked up by noon on the last day of the event.
- We might be unable to deliver certain large items because of space limitations (fenders, gas tanks, etc.).
- Orders can be paid for by credit card when ordering on the phone, or by cash (US Dollars) when picking up in person. **NO CHECKS PLEASE.**
- Sales Tax appropriate to each state will be charged.
- No shipping charges will be applied to any item you pick up at any of the above shows.





Antique Auto Parts

1958-1966

# BIG BIRD



Parts Listings . . . . . 132-245  
Detailed Index . . . . . 245-253

## How To Use THIS CATALOG



These page headers tell you which area of your car the parts on the page are for.

### INTERIOR TRIM

These sub-headers tell you which specific parts are listed below it.

This is the order of our listings:

Years of Application	Part Description	Part Number	Price
1955	Finish plate, 1 hole, used in early 1955 only, left (4 required)	B5S-4021145-A	41.95

### Door Garnish Rails

- 55-57 Door garnish rail, metal, right . . . . . B5S-4020906
- 55-57 Door garnish rail, metal, left . . . . . B5S-4020907

### Door Garnish Rail Vinyl Sets

*The 3-piece sets listed below include covers for right & left door garnish rails & the rear garnish rail, at the deck area behind the seat.*

- 1955 **NEW** Black #LB13 . . . . . B5S-4020908
- 1955 Dark green #LB24 . . . . . B5S-4020909

This italicized text is technical information about the parts listed below it.

Numbers in parentheses & italics are the recommended number required.





## Vinyl Seat Covers

MAC's seat covers are made from the finest reproduction vinyl available. Sewn in the original style, they feature the correct grains, colors & use original style welts & seams. We feel we offer the finest seat covers anywhere & your satisfaction, as always is our top priority.



The number (example: #6) following each color name is the identification that appears on our color sample cards. The first number listed is the outer color & the second number listed is the insert color.



All seat covers are oversize & require additional shipping.

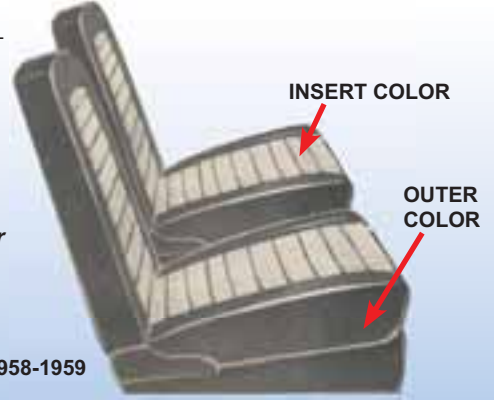

1958-1959

### Colors available for 1958 Thunderbirds



Black #1



White #2



Blue #4



Gulfstream #5



Green #6



Palomino #7



Red #8

## 1958

### Front Bucket Pairs Only

All 1958 seat covers come complete with vinyl-covered hardbacks & use silver welting as original.

1958	Black #1 & white #2, trim code XH . . . . .	UBF-260	275.95 pair
1958	Red #8 & white #2, trim code XG . . . . .	UBF-262	275.95 pair
1958	Blue #4 & white #2, trim code XE . . . . .	UBF-264	275.95 pair
1958	Gulfstream #5 & white #2, trim code XM . . . . .	UBF-266	275.95 pair
1958	Green #6 & white #2, trim code XF . . . . .	UBF-268	275.95 pair
1958	Palomino #7 & white #2, trim code XL . . . . .	UBF-270	275.95 pair

### Full Sets - Front & Rear

All 1958 seat covers come complete with vinyl-covered hardbacks & use silver welting as original.

1958	Black #1 & white #2, trim code XH . . . . .	UBC-261	440.95 set
1958	Red #8 & white #2, trim code XG . . . . .	UBC-263	440.95 set
1958	Blue #4 & white #2, trim code XE . . . . .	UBC-265	440.95 set
1958	Gulfstream #5 & white #2, trim code XM . . . . .	UBC-267	440.95 set
1958	Green #6 & white #2, trim code XF . . . . .	UBC-269	440.95 set
1958	Palomino #7 & white #2, trim code XL . . . . .	UBC-271	440.95 set

### Colors available for 1959 Thunderbirds



Black #1



White #2



Green #6



Hickory Tan (Palomino) #7



Red #8



Dark Blue #9



Light Blue #10

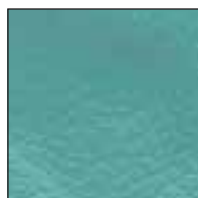

Turquoise #11

## 1959

### Front Bucket Pairs Only

All 1959 seat covers come complete with vinyl-covered hardbacks & use silver welting as original.

1959	Black #1 & white #2, trim code 8X . . . . .	UBF-260	275.95 pair
1959	Red #8 & white #2, trim code 9X . . . . .	UBF-262	275.95 pair
1959	Dark blue #9 & light blue #10, trim code 5X . . . . .	UBF-272	275.95 pair
1959	Turquoise #11 & white #2, trim code 7X . . . . .	UBF-274	275.95 pair
1959	Green #6 & white #2, trim code 6X . . . . .	UBF-268	275.95 pair
1959	Hickory tan (Palomino) #7 & white #2, trim code 5Y . . . . .	UBF-270	275.95 pair

### Full Sets - Front & Rear

1959	Black #1 & white #2, trim code 8X . . . . .	UBC-261	440.95 set
1959	Red #8 & white #2, trim code 9X . . . . .	UBC-263	440.95 set
1959	Dark blue #9 & light blue #10, trim code 5X . . . . .	UBC-273	440.95 set
1959	Turquoise #11 & white #2, trim code 7X . . . . .	UBC-275	440.95 set
1959	Green #6 & white #2, trim code 6X . . . . .	UBC-269	440.95 set
1959	Hickory tan (Palomino) #7 & white #2, trim code 5Y . . . . .	UBC-271	440.95 set



Just not sure which color?  
Order SAMPLE2 & we will mail you our FREE color sample card!



Because of the size of the Seat Cover Sets, additional shipping charges will be incurred.



## Colors available for 1960 Thunderbirds



## 1960

### Front Bucket Pairs Only

All 1960 seat covers are made with matching trim color welt as original.

1960	Black #12 & white #13, trim code 56 . . .	UBF-204	275.95 pair
1960	Red #14 & white #13, trim code 55 . . . .	UBF-205	275.95 pair
1960	Turquoise two-tone #17 & #18, trim code 57 . . . . .	UBF-206	275.95 pair
1960	Blue two-tone #15 & #16, trim code 52 . . .	UBF-207	275.95 pair
1960	Green two-tone #19 & #20, trim code 53 . . .	UBF-208	275.95 pair
1960	Brown (beige) two-tone #21 & #22, trim code 54 . . . . .	UBF-209	275.95 pair

### Full Sets - Front & Rear

All 1960 seat covers are made with matching trim color welt as original.

1960	Black #12 & white #13, trim code 56 . . .	UBC-204	440.95 set
1960	Red #14 & white #13, trim code 55 . . . .	UBC-205	440.95 set
1960	Turquoise two-tone #17 & #18, trim code 57 . . . . .	UBC-206	440.95 set
1960	Blue two-tone #15 & #16, trim code 52 . . .	UBC-207	440.95 set
1960	Green two-tone #19 & #20, trim code 53 . . .	UBC-208	440.95 set
1960	Brown (beige) two-tone #21 & #22, trim code 54 . . . . .	UBC-209	440.95 set

## Colors available for 1961 Thunderbirds



## 1961

### Front Bucket Pairs Only

All 1961 seat covers are made with matching trim color welt as original.

1961	Black #23, trim code 56 . . . . .	UBF-210	275.95 pair
1961	Red #8, trim code 55 . . . . .	UBF-211	275.95 pair
1961	Light blue metallic #24, trim code 52 . . .	UBF-212	275.95 pair
1961	Light beige (Pearl white) #26, trim code 54 . . . . .	UBF-213	275.95 pair
1961	Turquoise metallic #25, trim code 57 . . .	UBF-247	275.95 pair

### Full Sets - Front & Rear

1961	Black #23, trim code 56 . . . . .	UBC-210	440.95 set
1961	Red #8, trim code 55 . . . . .	UBC-211	440.95 set
1961	Light blue metallic #24, trim code 52 . . .	UBC-212	440.95 set
1961	Light beige (Pearl white) #26, trim code 54 . . . . .	UBC-213	440.95 set
1961	Turquoise metallic #25, trim code 57 . . .	UBC-247	440.95 set



See matching Kick Panels, Door Panels, Quarter Trim Panels & Arm Rest Covers on pages 140-144.



## Colors available for 1962 Thunderbirds

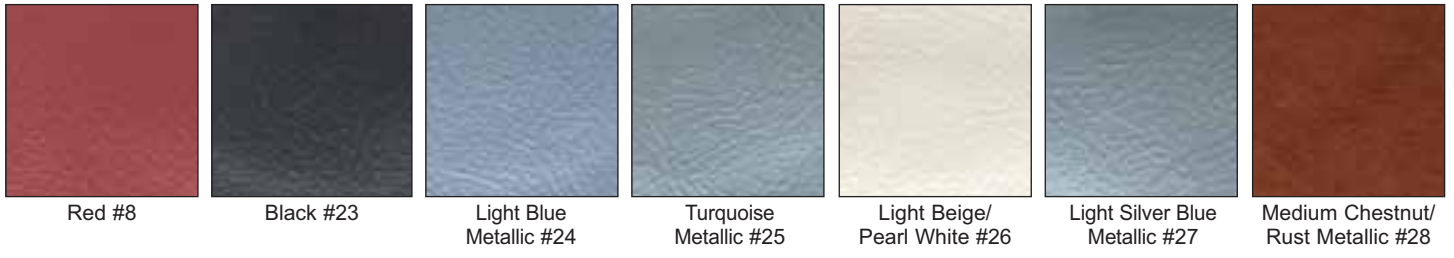

### 1962

#### Front Bucket Pairs Only

All 1962 seat covers are made with matching color welt as original.

1962	Black #23, trim code 56	UBF-210	275.95 pair
1962	Red #8, trim code 55	UBF-211	275.95 pair
1962	Light blue metallic #24, trim code 52	UBF-212	275.95 pair
1962	Light beige (Pearl white) #26, trim code 54	UBF-213	275.95 pair
1962	Light silver blue metallic #27, trim code 50	UBF-248	275.95 pair
1962	Turquoise metallic #25, trim code 57	UBF-249	275.95 pair
1962	Medium chestnut metallic (Rust) #28, trim code 59	UBF-250	275.95 pair

#### Full Sets - Front & Rear

1962	Black #23, trim code 56	UBC-210	440.95 set
1962	Red #8, trim code 55	UBC-211	440.95 set
1962	Light blue metallic #24, trim code 52	UBC-212	440.95 set
1962	Light beige (Pearl white) #26, trim code 54	UBC-213	440.95 set
1962	Light silver blue metallic #27, trim code 50	UBC-248	440.95 set
1962	Turquoise metallic #25, trim code 57	UBC-249	440.95 set
1962	Medium chestnut metallic (Rust) #28, trim code 59	UBC-250	440.95 set



See matching Kick Panels, Door Panels, Quarter Trim Panels & Arm Rest Covers on pages 140-144.

### Hog Ring Pliers & Rings

We offer high quality hog rings & pliers, for those who are skilled at installing their own seat covers. However, if you have never done this job before, we recommend that you take our premium seat cover sets to a professional trim installer, for best results. Their many years of experience have taught them countless techniques for getting the proper fit, without unnecessary wrinkles, sags, or other little imperfections. So unless you are experienced at installing reproduction automotive seat covers, check the yellow pages for a professional installer near you.

#### Hog Ring Pliers



ALL Professional quality . . . . . T4407U 25.25

#### Hog Rings



ALL 100 pieces . . . . . T4406U 2.95 set



Just not sure which color?  
Order SAMPLE2 & we will mail you our FREE color sample card!



Because of the size of the Seat Cover Sets, additional shipping charges will be incurred.





## Colors available for 1963 Thunderbirds



Red #8



Black #23



Light Beige/  
Pearl White #26



Medium Chestnut/  
Rust #28



Black #29



Red #30



Medium Blue #31



Light Blue #32



Medium Turquoise  
#33



Light Turquoise #34



Light Beige/  
Pearl White #35



Light Rose Beige  
#36



Light Rose Beige  
#37



Medium Silver Blue  
#38



Light Silver Blue #39



Light Gold/  
Silver Gold #40



Light Gold/  
Silver Gold #41



Medium Chestnut/  
Rust #42

## 1963

All 1963 seat covers have unique vachette inserts & use silver welting as original.  
In these listings, the second number is the vachette insert number.

### Front Bucket Pairs Only

1963	Black #23 & #29, trim code 56	UBF-214	275.95 pair
1963	Red #8 & #30, trim code 55	UBF-215	275.95 pair
1963	Medium blue #31 & Light blue #32, trim code 52	UBF-216	275.95 pair
1963	Light rose beige #36 & #37, trim code 51	UBF-217	275.95 pair
1963	Medium silver blue #38 & Light silver blue #39, trim code 50	UBF-218	275.95 pair
1963	Light beige (Pearl white) #26 & #35, trim code 54	UBF-219	275.95 pair
1963	Medium turquoise #33 & Light turquoise #34, trim code 57	UBF-220	275.95 pair
1963	Light gold (Silver gold) #40 & #41, trim code 58	UBF-251	275.95 pair
1963	Medium chestnut (Rust) #28 & #42, trim code 59	UBF-252	275.95 pair

### Full Sets - Front & Rear

1963	Black #23 & #29, trim code 56	UBC-214	440.95 set
1963	Red #8 & #30, trim code 55	UBC-215	440.95 set
1963	Medium blue #31 & Light blue #32, trim code 52	UBC-216	440.95 set
1963	Light rose beige #36 & #37, trim code 51	UBC-217	440.95 set
1963	Medium silver blue #38 & Light silver blue #39, trim code 50	UBC-218	440.95 set
1963	Light beige (Pearl white) #26 & #35, trim code 54	UBC-219	440.95 set
1963	Medium turquoise #33 & Light turquoise #34, trim code 57	UBC-220	440.95 set
1963	Light gold (Silver gold) #40 & #41, trim code 58	UBC-251	440.95 set
1963	Medium chestnut (Rust) #28 & #42, trim code 59	UBC-252	440.95 set



## Colors available for 1964 Thunderbirds



Red #8



Black #23



Light Blue #24



Light Turquoise #25



Light Silver Blue #27



Light Rose Beige #36



Light Beige/Silver Gold #40



White #43



Medium Palomino #44



Not sure which color you need?

Order **SAMPLE2** & we will mail you our **FREE** color sample card!



Because of the size of the Seat Cover Sets, additional shipping charges will be incurred.



See matching Kick Panels, Door Panels, Quarter Trim Panels & Arm Rest Covers on pages 140-144.

### 1964 without Reclining Passenger Seat

#### Front Bucket Pairs Only

All 1964 seat covers are made with matching color welting as original & include rear center armrest cover.

1964	Black #23, trim codes 56, 56A & 56B . . .	UBF-221	275.95 pair
1964	Red #8, trim codes 55, 55A & 55B . . . . .	UBF-222	275.95 pair
1964	White #43, trim code 53 . . . . .	UBF-223	275.95 pair
1964	Light turquoise #25, trim codes 57, 57A & 57B . . . . .	UBF-225	275.95 pair
1964	Light blue #24, trim codes 52 & 52A . . .	UBF-226	275.95 pair
1964	Light silver blue #27, trim codes 51, 51A & 51B . . . . .	UBF-253	275.95 pair
1964	Light beige (Silver gold) #40, trim codes 54, 54A & 54B . . . . .	UBF-254	275.95 pair
1964	Light rose beige #36, trim codes 50 & 50A . . . . .	UBF-255	275.95 pair
1964	Medium palomino #44, trim codes 59 & 59A . . . . .	UBF-256	275.95 pair

#### Full Sets - Front & Rear

1964	Black #23, trim codes 56, 56A & 56B . . .	UBC-221	440.95 set
1964	Red #8, trim codes 55, 55A & 55B . . . . .	UBC-222	440.95 set
1964	White #43, trim code 53 . . . . .	UBC-223	440.95 set
1964	Light turquoise #25, trim codes 57, 57A & 57B . . . . .	UBC-225	440.95 set
1964	Light blue #24, trim codes 52 & 52A . . .	UBC-226	440.95 set
1964	Light silver blue #27, trim codes 51, 51A & 51B . . . . .	UBC-253	440.95 set
1964	Light beige (Silver gold) #40, trim codes 54, 54A & 54B . . . . .	UBC-254	440.95 set
1964	Light rose beige #36, trim codes 50 & 50A . . . . .	UBC-255	440.95 set
1964	Medium palomino #44, trim codes 59 & 59A . . . . .	UBC-256	440.95 set

### 1964 with Reclining Passenger Seat

#### Front Bucket Pairs Only

All 1964 seat covers are made with matching color welting as original & include rear center armrest cover.

1964	Black #23, trim codes 56, 56A & 56B . . .	UBF-227	330.95 pair
1964	Red #8, trim codes 55, 55A & 55B . . . . .	UBF-228	330.95 pair
1964	White #43, trim code 53 . . . . .	UBF-201	330.95 pair
1964	Light turquoise #25, trim codes 57, 57A & 57B . . . . .	UBF-231	330.95 pair
1964	Light blue #24, trim codes 52 & 52A . . .	UBF-232	330.95 pair
1964	Light silver blue #27, trim codes 51, 51A & 51B . . . . .	UBF-229	330.95 pair
1964	Light beige (Silver gold) #40, trim codes 54, 54A & 54B . . . . .	UBF-281	330.95 pair
1964	Light rose beige #36, trim codes 50 & 50A . . . . .	UBF-291	330.95 pair
1964	Medium palomino #44, trim codes 59 & 59A . . . . .	UBF-282	330.95 pair

#### Full Sets - Front & Rear

1964	Black #23, trim codes 56, 56A & 56B . . .	UBC-227	525.95 set
1964	Red #8, trim codes 55, 55A & 55B . . . . .	UBC-228	525.95 set
1964	White #43, trim code 53 . . . . .	UBC-201	525.95 set
1964	Light turquoise #25, trim codes 57, 57A & 57B . . . . .	UBC-231	525.95 set
1964	Light blue #24, trim codes 52 & 52A . . .	UBC-232	525.95 set
1964	Light silver blue #27, trim codes 51, 51A & 51B . . . . .	UBC-229	525.95 set
1964	Light beige (Silver gold) #40, trim codes 54, 54A & 54B . . . . .	UBC-281	525.95 set
1964	Light rose beige #36, trim codes 50 & 50A . . . . .	UBC-291	525.95 set
1964	Medium palomino #44, trim codes 59 & 59A . . . . .	UBC-282	525.95 set



## Colors available for 1965 Thunderbirds



Red #8



Black #23



Light Blue #24



Light Aqua #25



Light Silver Mink #27



Light Beige/  
Silver Gold #40



White #43



Medium Palomino  
#44



Burgundy #46



Parchment #47



Light Ivy Gold/  
Green #48

### 1965 without Reclining Passenger Seat

All 1965 seat covers are made with matching trim color welt as original & include rear center armrest cover. Listed are the only color choices presently available.

#### Front Bucket Pairs Only

1965	Black #23, trim code 26	UBF-221	275.95 pair
1965	Red #8, trim code 25	UBF-222	275.95 pair
1965	White #43, trim code G2-G9 or P2-P9	UBF-223	275.95 pair
1965	Light silver mink (Silver blue) #27, trim code 21	UBF-290	275.95 pair
1965	Light aqua #25, trim code 27	UBF-225	275.95 pair
1965	Light blue #24, trim code 22	UBF-226	275.95 pair
1965	Light ivy gold (Green) #48, trim code 28	UBF-224	275.95 pair
1965	Burgundy #46, trim code 23	UBF-258	275.95 pair
1965	Light beige (Silver gold) #40, trim code 24	UBF-259	275.95 pair
1965	Medium palomino #44, trim code 29	UBF-288	275.95 pair
1965	Parchment #47, trim code 7D	UBF-289	275.95 pair

#### Full Sets - Front & Rear

1965	Black #23, trim code 26	UBC-221	440.95 set
1965	Red #8, trim code 25	UBC-222	440.95 set
1965	White #43, trim code G2-G9 or P2-P9	UBC-223	440.95 set
1965	Light silver mink (Silver blue) #27, trim code 21	UBC-290	440.95 set
1965	Light aqua #25, trim code 27	UBC-225	440.95 set
1965	Light blue #24, trim code 22	UBC-226	440.95 set
1965	Light ivy gold (Green) #48, trim code 28	UBC-224	440.95 set
1965	Burgundy #46, trim code 23	UBC-258	440.95 set
1965	Light beige (Silver gold) #40, trim code 24	UBC-259	440.95 set
1965	Medium palomino #44, trim code 29	UBC-288	440.95 set
1965	Parchment #47, trim code 7D	UBC-289	440.95 set

### 1965 with Reclining Passenger Seat

All 1965 seat covers are made with matching trim color welt as original & include rear center armrest cover. Listed are the only color choices presently available.

#### Front Bucket Pairs Only

1965	White #43, trim code G2-G9 or P2-P9	UBF-201	330.95 pair
1965	Black #23, trim code 56	UBF-227	330.95 pair
1965	Red #8, trim code 55	UBF-228	330.95 pair
1965	Light silver mink (Silver blue) #27, trim code 51	UBF-229	330.95 pair
1965	Light aqua #25, trim code 57	UBF-231	330.95 pair
1965	Light blue #24, trim code 52	UBF-232	330.95 pair
1965	Light ivy gold (Green) #48, trim code 58	UBF-230	330.95 pair
1965	Burgundy #46, trim code 53	UBF-280	330.95 pair
1965	Light beige (Silver gold) #40, trim code 54	UBF-281	330.95 pair
1965	Medium palomino #44, trim code 59	UBF-282	330.95 pair
1965	Parchment #47, trim code XD	UBF-283	330.95 pair

#### Full Sets - Front & Rear

1965	White #43, trim code G2-G9 or P2-P9	UBC-201	525.95 set
1965	Black #23, trim code 56	UBC-227	525.95 set
1965	Red #8, trim code 55	UBC-228	525.95 set
1965	Light silver mink (Silver blue) #27, trim code 51	UBC-229	525.95 set
1965	Light aqua #25, trim code 57	UBC-231	525.95 set
1965	Light blue #24, trim code 52	UBC-232	525.95 set
1965	Light ivy gold (Green) #48, trim code 58	UBC-230	525.95 set
1965	Burgundy #46, trim code 53	UBC-280	525.95 set
1965	Light beige (Silver gold) #40, trim code 54	UBC-281	525.95 set
1965	Medium palomino #44, trim code 59	UBC-282	525.95 set
1965	Parchment #47, trim code XD	UBC-283	525.95 set

### Hog Ring Pliers & Rings

We offer high quality hog rings & pliers, for those who are skilled at installing their own seat covers. However, if you have never done this job before, we recommend that you take our premium seat cover sets to a professional trim installer, for best results. Their many years of experience have taught them countless techniques for getting the proper fit, without unnecessary wrinkles, sags, or other little imperfections. So unless you are experienced at installing reproduction automotive seat covers, check the yellow pages for a professional installer near you.

#### Hog Ring Pliers



ALL Professional quality . . . . . T4407U 25.25

#### Hog Rings



ALL 100 pieces . . . . . T4406U 2.95 set





## Colors available for 1966 Thunderbirds



Black #23



Light Aqua #25



Light Silver Mink #27



Medium Emberglo/  
Rust #28



White #43



Burgundy #46



Parchment #47



Light Ivy Gold/  
Green #48



Red #49



Dark Blue #50



Just not sure which color?  
Order **SAMPLE2** & we will mail you  
our **FREE** color sample card!



See matching Kick Panels, Door Panels, Quarter Trim  
Panels & Arm Rest Covers on pages 140-144.

### 1966 without Reclining Passenger Seat

All 1966 vinyl seat covers are made with matching trim color welt  
as original & include rear center armrest cover.

#### Front Bucket Pairs Only

1966	White #43, trim code G1-G9 or P1-P9	UBF-202	275.95 pair
1966	Black #23, trim code 26	UBF-233	275.95 pair
1966	Burgundy #46, trim code 23	UBF-234	275.95 pair
1966	Red #49, trim code 25	UBF-235	275.95 pair
1966	Dark blue #50, trim code 22	UBF-236	275.95 pair
1966	Light ivy gold (Green) #48, trim code 28	UBF-237	275.95 pair
1966	Parchment #47, trim code B2-B9	UBF-238	275.95 pair
1966	Medium emberglo (Rust) #28, trim code 24	UBF-239	275.95 pair
1966	Light silver mink (Silver blue) #27, trim code 21	UBF-286	275.95 pair
1966	Light aqua #25, trim code 27	UBF-287	275.95 pair

#### Full Sets - Front & Rear

1966	White #43, trim code G1-G9 or P1-P9	UBC-202	440.95 set
1966	Black #23, trim code 26	UBC-233	440.95 set
1966	Burgundy #46, trim code 23	UBC-234	440.95 set
1966	Red #49, trim code 25	UBC-235	440.95 set
1966	Dark blue #50, trim code 22	UBC-236	440.95 set
1966	Light ivy gold (Green) #48, trim code 28	UBC-237	440.95 set
1966	Parchment #47, trim code B2-B9	UBC-238	440.95 set
1966	Medium emberglo (Rust) #28, trim code 24	UBC-239	440.95 set
1966	Light silver mink (Silver blue) #27, trim code 21	UBC-286	440.95 set
1966	Light aqua #25, trim code 27	UBC-287	440.95 set

### 1966 with Reclining Passenger Seat

All 1966 vinyl seat covers are made with matching trim color welt  
as original & include rear center armrest cover.

#### Front Bucket Pairs Only

1966	White #43, trim code G1-G9 or P1-P9	UBF-203	330.95 pair
1966	Black #23, trim code 56	UBF-240	330.95 pair
1966	Burgundy #46, trim code 53	UBF-241	330.95 pair
1966	Red #49, trim code 55	UBF-242	330.95 pair
1966	Dark blue #50, trim code 52	UBF-243	330.95 pair
1966	Light ivy gold (Green) #48, trim code 58	UBF-244	330.95 pair
1966	Parchment #47, trim code K2-K9	UBF-245	330.95 pair
1966	Medium emberglo (Rust) #28, trim code 54	UBF-246	330.95 pair
1966	Light silver mink (Silver blue) #27, trim code 51	UBF-284	330.95 pair
1966	Light aqua #25, trim code 57	UBF-285	330.95 pair

#### Full Sets - Front & Rear

1966	White #43, trim code G1-G9 or P1-P9	UBC-203	525.95 set
1966	Black #23, trim code 56	UBC-240	525.95 set
1966	Burgundy #46, trim code 53	UBC-241	525.95 set
1966	Red #49, trim code 55	UBC-242	525.95 set
1966	Dark blue #50, trim code 52	UBC-243	525.95 set
1966	Light ivy gold (Green) #48, trim code 58	UBC-244	525.95 set
1966	Parchment #47, trim code K2-K9	UBC-245	525.95 set
1966	Medium emberglo (Rust) #28, trim code 54	UBC-246	525.95 set
1966	Light silver mink (Silver blue) #27, trim code 51	UBC-284	525.95 set
1966	Light aqua #25, trim code 57	UBC-285	525.95 set



Because of the size of the Seat Cover Sets, additional shipping charges will be incurred.



## Molded Bucket Seat Foam

Are your bucket seats missing pieces of foam, or are they just compressed from years of use? Restore them by replacing the foam & get that "like-new" feeling. Each set includes both the foam seat cushion & the foam backrest cushion, molded as original.



- 58-60 2-piece set (2 sets required) (shown) . . . . . U2SF1 118.95 set
- 61-62 2-piece set (2 sets required) . . . . . U2SF2 118.95 set
- 1963 2-piece set (2 sets required) . . . . . U2SF3 118.95 set
- 64-65 2-piece set, standard seats  
(1 or 2 sets required) (shown) . . . . . U2SF4 126.95 set
- 64-65 3-piece set, reclining passenger seat . . . . . U2SF5 118.95 set
- 1966 2-piece set, standard seats  
(1 or 2 sets required) . . . . . U2SF6 118.95 set
- 1966 3-piece set, reclining passenger seat . . . . . U2SF7 118.95 set

## Hog Ring Pliers & Rings

We offer high quality hog rings & pliers, for those who are skilled at installing their own seat covers. However, if you have never done this job before, we recommend that you take our premium seat cover sets to a professional trim installer, for best results. Their many years of experience have taught them countless techniques for getting the proper fit, without unnecessary wrinkles, sags, or other little imperfections. So unless you are experienced at installing reproduction automotive seat covers, check the yellow pages for a professional installer near you.

### Hog Ring Pliers



- ALL Professional quality . . . . . T4407U 25.25

### Hog Rings



- ALL 100 pieces . . . . . T4406U 2.95 set

## Power Seat Switch Knob & Housing

If your switch is working but the knob is broken off, we have a simple fix—our knob & housing! A universal chrome knob is installed into a reproduction pot-metal housing so you can attach it to your switch & get your seat moving again.



- 58-66 . . . . . C1SZ-14A701 23.95

## Power Seat Switches & Knobs

**How many cars have you seen with power seats that didn't work because the switch was bad & no new replacements were available? Well now we have switches for 1958 thru 1965.**

- 1958 Switch, with black knob . . . . . B8S-14A701 84.95
- 59-60 Switch, with white knob . . . . . B9SZ-14A701-A 84.95
- 61-62 Switch, with chrome knob, one 4  
wire plug & one 3 wire plug . . . C1SF-14A701-C 84.95
- 62-63 Switch, with chrome knob, one 3  
wire plug & one 2 wire plug . . . C1SF-14A701-A 84.95
- 64-65 Switch, with chrome knob . . . . . C4SZ-14A701-A 84.95
- 61-63 Switch retainer . . . . . C2SZ-14B691 6.95

## Power Seat Wires

- 58-59 Seat switch wire, 12 terminals . . . . . FEV-14642-A 39.95
- 58-60 Regulator relay feed wire, 106" long . B8S-14643-A 8.95
- 58-60 Circuit breaker to starter relay wire,  
52" long . . . . . B8S-14682-A 19.95
- 1960 Circuit breaker to seat solenoid wire,  
52" long . . . . . FEV-14682-C 7.95

## Power Seat Regulator Motor Drive Coupler (as required)



- 61-66 Power seat regulator  
motor drive . . . . . B5A-7023440-A 14.95

## Manual Seat Adjustment Knob & Clip (2 required)



- 61-63 Knob, manual bucket seat, black  
plastic, clip is not included (listed  
below), **Genuine Ford** . . . . . C5AZ-6261753-B 6.95
- 61-63 Knob clip, for above knob,  
manual bucket seat . . . . . C5AZ-6262060-A 2.95
- 61-63 **NEW Save** Knob & clip, black  
plastic, for manual bucket seat,  
includes clip, reproduction . . . C5AZ-6261753-BR 7.95



## Seat Hinge Cover Sets

Each set includes 2 each of both the inside & outside hinge covers, plus the 4 attaching screws. Replace those scuffed & cracked originals with brand new pieces now!



- 58-60 4 pieces, black, plastic, enough for 2 seats . . . . . B8S-62140-BLK 33.95 set
- 58-60 4 pieces, red, plastic, enough for 2 seats (shown) . . B8S-62140-RED 33.95 set



- 61-62 2 pieces, chrome, round, enough for 1 seat (2 sets required) . . . . . C1SB-6361697-ST 28.95 set



- 61-63 4 pieces, black . . . . . C1SB-6361694-BLK 29.95 set
- 61-63 4 pieces, blue . . . . . C1SB-6361694-BLU 29.95 set
- 61-63 4 pieces, bone . . . . . C1SB-6361694-BONE 29.95 set
- 61-63 4 pieces, red . . . . . C1SB-6361694-RED 29.95 set
- 61-63 4 pieces, tan . . . . . C1SB-6361694-TAN 29.95 set

## Seat Side Skirts (2 pairs required)

1 pair is required for each seat.



- 61-63 White . . . . . C1SZ-6362162-WHT 120.95 pair
- 61-63 Black . . . . . C1SZ-6362162-BLK 73.95 pair
- 61-63 Red (shown) . . . . . C1SZ-6362162-RED 120.95 pair

## Seat Hardware

- 61-63 Fiberglass side installation hardware set, 6 pan-head Phillips screws, 1 set does both front seats . . . . . 2HK79A 5.95 set
- 61-63 Seat hinge elbow screw set, 2 pan-head Phillips screws, 1 set does both sides . 2HK79B 2.95 set



- 63-66 Plug set, 4 pieces, for front seat mounting holes, rubber, 1-1/2" x 23/64" (shown) . . . . . 377901-ST 6.95 set
- 63-66 Plug for front seat mounting holes, rubber, 1-1/2" x 23/64" (4 required) (shown) . . 377901-S 3.95
- 1964 Front seatback panel installation set, 12 oval-head Phillips screws, 1 set does 2 seatbacks . . . . . 2HK91R 4.95 set
- 1965 Rear seat panel screw set, 4 oval-head Phillips screws, 1 set does 2 sides . . . 2HK91S 2.95 set
- 64-66 Front seatback stop hardware set, 8 oval-head Phillips screws, does both seats. . . . . 2HK79C 3.95 set

## Interior Kick Panels



From 1958 thru 1960 all interior kick panels were vinyl covered. The partial oval indentation on the lower part has been accurately reproduced on the 1958 & 1959 panels as is the four stripe indentation on the 1960.



### 1958-1959

- 58-59 White . . . . . B8S-6302344-WHT 92.95 pair
- 58-59 Light blue . . . . . B9S-6302344-LBL 92.95 pair



### 1960

- 1960 Black & white, coupe . . . . . COSZ-6302344-BW 78.95 pair
- 1960 Two tone blue, coupe . . . . . COSZ-6302344-BLU 78.95 pair
- 1960 Red & white, coupe . . . . . COSZ-6302344-RW 78.95 pair
- 1960 Two tone beige, coupe . . . . . COSZ-6302344-BGE 78.95 pair
- 1960 Turquoise & white, coupe . . . . . COSZ-6302344-TW 78.95 pair
- 1960 Black & white, convertible . . . . . COSZ-7602344-BW 78.95 pair
- 1960 Two tone blue, convertible (shown) . . . . . COSZ-7602344-BLU 78.95 pair
- 1960 Red & white, convertible . . . . . COSZ-7602344-RW 78.95 pair
- 1960 Two tone beige, convertible . . . . . COSZ-7602344-BGE 78.95 pair
- 1960 Turquoise & white, convertible . . . . . COSZ-7602344-TW 78.95 pair

### 1961-1966

These kick panels are black, molded & grained plastic & they can be painted to match your interior.



- 61-62 (shown) . . . . . C1SZ-6302344-PR 108.95 pair
- 1963 . . . . . C3SZ-6302344-PR 101.95 pair



- 64-66 Includes removable fuse panel cover, convertible (shown) . . . . . C4SZ-7602344-PR 108.95 pair
- 64-66 Includes removable fuse panel cover, hardtop . . . . . C4SZ-6302344-PR 108.95 pair





**Seatbelts**



If you haven't already installed seat belts in your classic ride, we highly recommend it. Our universal style seat belts feature a chrome lift latch & are available in 10 colors to match almost any interior. Sold per passenger, each belt includes washers, bolts, nuts & basic instructions on how to install. The 60" size is standard, for a little extra breathing room, order the 74" length. These seat belts do not include instructions on where to mount. Proper installation is at the risk & responsibility of the customer.



**60" Long**

Black . . . . .	SEATBELT-BLK60	23.95
White . . . . .	SEATBELT-WHT60	23.95
Light gray . . . . .	SEATBELT-LGR60	23.95
Dark gray . . . . .	SEATBELT-DGR60	23.95
Light tan . . . . .	SEATBELT-LTN60	23.95
Dark tan . . . . .	SEATBELT-DTN60	23.95
Light blue . . . . .	SEATBELT-LBL60	23.95
Dark blue . . . . .	SEATBELT-DBL60	23.95
Bright red . . . . .	SEATBELT-BRD60	23.95
Dark red . . . . .	SEATBELT-DRD60	23.95

**74" Long**

Black . . . . .	SEATBELT-BLK74	26.95
White . . . . .	SEATBELT-WHT74	26.95
Light gray . . . . .	SEATBELT-LGR74	26.95
Dark gray . . . . .	SEATBELT-DGR74	26.95
Light tan . . . . .	SEATBELT-LTN74	26.95
Dark tan . . . . .	SEATBELT-DTN74	26.95
Light blue . . . . .	SEATBELT-LBL74	26.95
Dark blue . . . . .	SEATBELT-DBL74	26.95
Bright red . . . . .	SEATBELT-BRD74	26.95
Dark red . . . . .	SEATBELT-DRD74	26.95

**Windlace**

Please measure your original windlace so you get as much as you need. We suggest 10 feet, but we can cut the windlace to any length you require. Price shown is per foot, order as required.

**Cloth**

ALL Black . . . . .	WLC-02600-BLK	2.25 foot	ALL Green . . . . .	WLC-02600-GRN	2.25 foot
ALL Red . . . . .	WLC-02600-RED	2.25 foot	ALL Blue . . . . .	WLC-02600-BLU	2.25 foot
ALL White . . . . .	WLC-02600-WHT	2.25 foot	ALL Dark blue . . . . .	WLC-02600-DBL	2.25 foot
ALL Gray . . . . .	WLC-02600-GRY	2.25 foot	ALL Turquoise . . . . .	WLC-02600-TUR	2.25 foot
ALL Brown . . . . .	WLC-02600-BRN	2.25 foot			



**Vinyl**

ALL Black . . . . .	WLV-02600-BLK	1.95 foot	ALL Ivy gold . . . . .	WLV-02600-IGO	1.95 foot
ALL Red . . . . .	WLV-02600-RED	1.95 foot	ALL Saddle . . . . .	WLV-02600-SAD	1.95 foot
ALL Green . . . . .	WLV-02600-GRN	1.95 foot	ALL Ginger . . . . .	WLV-02600-GIN	1.95 foot
ALL Light blue . . . . .	WLV-02600-LBL	1.95 foot	ALL Maroon . . . . .	WLV-02600-MAR	1.95 foot
ALL Dark blue . . . . .	WLV-02600-DBL	1.95 foot	ALL Light . . . . .	WLV-02600-LTPAR	1.95 foot
ALL Aqua . . . . .	WLV-02600-AQU	1.95 foot			





## Door Trim Panels



Carefully remove all of the bright trim from your original set of door panels & install it on our reproduction panels to finish them off.

### All 1958s & 1959s with Vinyl Seats

1958-1959 door trim panels are Bison grain vinyl & have built-in armrests & embossing on the lower section, as original. The first color listed is the color of the upper part of the door panel, the second color is the lower. The two-digit trim code is shown under "trim" on the patent plate, on the left door hinge pillar.

**OS** All door panels are oversized & require additional shipping charges.



1958	Black #1 & white #2, trim code XH (shown) . . . . .	B8S-23942-BLKW	575.95 pair
1958	Red #8 & white #2, trim code XG . . . . .	B8S-23942-REDW	575.95 pair
1958	Blue #4 & white #2, trim code XE . . . . .	B8S-23942-BLUW	575.95 pair
1958	Gulfstream #5 & white #2, trim code XM . . . . .	B8S-23942-TURW	575.95 pair
1958	Green #6 & white #2, trim code XF . . . . .	B8S-23942-GRNW	575.95 pair
1958	Palomino #7 & white #2, trim code XL . . . . .	B8S-23942-TANW	575.95 pair
1959	Black #1 & white #2, trim code 8X . . . . .	B8S-23942-BLKW	575.95 pair
1959	Red #8 & white #2, trim code 9X . . . . .	B8S-23942-REDW	575.95 pair
1959	Dark blue #9 & light blue #10, trim code 5X . . . . .	B9S-23942-BLBL	602.95 pair
1959	Green #6 & white #2, trim code 6X . . . . .	B8S-23942-GRNW	575.95 pair
1959	Hickory tan (Palomino) #7 & white #2, trim code 5Y . . . . .	B8S-23942-TANW	575.95 pair
1959	Turquoise #11 & white #2, trim code XM . . . . .	B9S-23942-TURW	602.95 pair
58-60	Door trim panel lower retainer, secures the bottom of the door panel (2 required) . . . . .	B7A-7021032-AP	22.95

### 1959 with Leather Seats

Solid color door panels were used only when the car had the optional leather seat covers. Our panels are covered with Bison grain vinyl.

1959	Black # 1, trim code 1Y . . . . .	B9S-23942-BLKL	602.95 pair
1959	Red #8, trim code 4Y . . . . .	B9S-23942-REDL	602.95 pair
1959	Hickory tan (Palomino) #7, trim code 2Y . . . . .	B9S-23942-TANL	602.95 pair
1959	Turquoise #11, trim code 3Y . . . . .	B9S-23942-TURL	602.95 pair



Carefully remove all of the bright trim from your original set of door panels & install it on our reproduction panels to finish them off.

### 1960 with Vinyl Seats

Our 1960 door trim panels are made with Pebble grain vinyl. The panels have horizontal & vertical embossed lines with buttons (as original) for cars with vinyl seats. The two-digit trim code is shown under "trim" on the patent plate, on the left door hinge pillar. Trim panel insert colors are listed first.

**OS** All door panels are oversized & require additional shipping charges.



1960	Black #12 & white #13, trim code 56 . . . . .	COSZ-23942-BLKW	602.95 pair
1960	Red #14 & white #13, trim code 55 . . . . .	COSZ-23942-REDW	602.95 pair
1960	Dark blue #15 & light blue #16, trim code 52 (shown) . . . . .	COSZ-23942-BLBL	602.95 pair
1960	Dark turquoise #17 & light turquoise #18, trim code 57 . . . . .	COSZ-23942-TQTQ	602.95 pair
1960	Dark green #19 & light green #20, trim code 53 . . . . .	COSZ-23942-GNGN	602.95 pair
1960	Dark beige #21 & light beige #22, trim code 54 . . . . .	COSZ-23942-BGBG	602.95 pair
58-60	Door trim panel lower retainer, secures the bottom of the door panel (2 required) . . . . .	B7A-7021032-AP	22.95

### 1960 with Leather Seats

Solid color door panels were used only with leather seat covers. Our panels are covered with pebble grain vinyl.

1960	Black #12, trim code 86 . . . . .	COSZ-23942-BLKL	602.95 pair
1960	Red #14, trim code 85 . . . . .	COSZ-23942-REDL	602.95 pair
1960	Dark turquoise #17, trim code 87 . . . . .	COSZ-23942-TURL	602.95 pair
1960	Dark beige #21, trim code 84 . . . . .	COSZ-23942-BGEL	602.95 pair

### 1961 - Early 1962

The 1961-early 1962 door panels listed below do not have armrests: you must re-use your originals. In late 1962 Ford changed the door panels to the 1963 style, which has built-in armrests.



61-62	Black (shown) . . . . .	C1SZ-23942-BLK	600.95 pair
61-62	White . . . . .	C1SZ-23942-WHT	600.95 pair
61-63	Door trim panel lower retainer, secures the bottom of the door panel (2 required) . . . . .	C1SB-6321032-BP	22.95

### Late 1962 - 1963

These door panels are only for late 1962-63 cars with built-in armrests. Early 1962 models do not have built-in armrests. See important note at the top of page 143.

62-63	Black . . . . .	C2SZ-23942-BLK	602.95 pair
62-63	White (shown) . . . . .	C2SZ-23942-WHT	602.95 pair
61-63	Door trim panel lower retainer, secures the bottom of the door panel (2 required) . . . . .	C1SB-6321032-BP	22.95



Late 1962 - 1963

Important note for late 1962-1963 Thunderbird owners: These combo door trim panels are the 1963 style with a front depression shaped & sized to accommodate the currently available 1961-1962 dash pad. Only use these combo interior door panels if you intend to install the currently available 1961-1962 dash pad on your 1963 vehicle. Your original trim must be transferred to these new vinyl panels.

OS All door panels are oversized & require additional shipping charges.



- 62-63 Black (shown) . . . . . C3SZ-23942-BLK 602.95 pair
62-63 White . . . . . C3SZ-23942-WHT 602.95 pair
61-63 Door trim panel lower retainer, secures the bottom of the door panel (2 required) . . . . C1SB-6321032-BP 22.95

1964 thru 1966

These reproduction door panels do not include the original bright trim. It must be transferred over from original panels. Only Landau door panels will accept the upper door woodgrain panels that were unique to that model.



- 1964 Black, except Landau (shown) . . C4SZ-23942-BLK 602.95 pair
1964 White, except Landau . . . . . C4SZ-23942-WHT 602.95 pair
1964 Black, Landau . . . . . C4SZ-23942-LANBLK 602.95 pair
1964 White, Landau . . . . . C4SZ-23942-LANWHT 602.95 pair



- 1965 Black, except Landau . . . . . C5SZ-23942-BLK 602.95 pair
1965 White, except Landau . . . . . C5SZ-23942-WHT 602.95 pair
1965 Black, Landau (shown) . . . . C5SZ-23942-LANBLK 602.95 pair
1965 White, Landau . . . . . C5SZ-23942-LANWHT 602.95 pair

- 1966 Black, all models . . . . . C6SZ-23942-BLK 602.95 pair
1966 White, all models . . . . . C6SZ-23942-WHT 602.95 pair

Door Panel Pull Cups (2 required)

- 58-59 Paint to match . . . . . B8S-24142 22.95
62-63 Paint to match, late 1962-63 . . . . . B8S-24142 22.95

Door Panel Retainer Set

- 61-63 4 pieces, chrome, these secure the door panels at the edge & are usually pretty rusty . . . . C2SZ-63237A24-ST 79.95 set

Vinyl Pads for Door Trim Panel Armrest Pull, 1965 & 1966 (2 required)

If your car was originally equipped with carpeting on the lower part of the doors, we sell door carpets (in pairs) as a separate item. See listings on page 147.

This vinyl pad fits in the bottom of the well that is the built-in door pull on all '65 & '66 T-Bird door panels.

- 65-66 Black . . . . . C5SZ-6324046-BLK 3.95
65-66 Bone white . . . . . C5SZ-6324046-WHT 3.95
65-66 Parchment, ideal for dyeing . . . . . C5SZ-6324046-PAR 3.95
65-66 Bright red . . . . . C5SZ-6324046-BRD 3.95
65-66 Dark red . . . . . C5SZ-6324046-DRD 4.95

Door Panel Aluminum Trim

- 61-62 1961 & early 1962 coupe with manual windows, right . . . C1SZ-63237A22-EMW 95.95
61-62 1961 & early 1962 coupe with manual windows, left . . . C1SZ-63237A23-EMW 95.95
61-62 1961 & early 1962 coupe with power windows, right . . . C1SZ-63237A22-EPW 95.95
61-62 1961 & early 1962 coupe with power windows, left . . . C1SZ-63237A23-EPW 95.95
61-62 1961 & early 1962 convertible with manual windows, left . . . . . C1SZ-76237A23-EMW 95.95
61-62 1961 & early 1962 convertible with power windows, left . . . . C1SZ-76237A23-EPW 95.95
1962 Late 1962 coupe or convertible, with power windows, right . . . . . C2SZ-63237A22-LPW 95.95
1962 Late 1962 coupe, with power windows, left . . . . . C2SZ-63237A23-LPW 95.95
1962 Late 1962 convertible, with manual windows, left . . . C2SZ-76237A23-LMW 95.95
1962 Late 1962 convertible, with power windows, left . . . . C2SZ-76237A23-LPW 95.95
62-63 Late 1962-63 coupe or convertible, with manual windows, right . . . . . C2SZ-76237A22-LMW 95.95
62-63 Late 1962-63 coupe, with manual windows, without remote control mirror, left . . . . . C2SZ-63237A23-LMW 95.95
62-63 NEW Nail strip, long, right, late 62-63, all body styles . . . . . C2SZ-637A22-LG 8.95
62-63 NEW Nail strip, short, right, late 62-63, all body styles . . . . . C2SZ-637A22-SH 4.95
62-63 NEW Nail strip, long, left, late 62-63, all body styles . . . . . C2SZ-637A23-LG 8.95
62-63 NEW Nail strip, short, left, late 62-63, all body styles . . . . . C2SZ-637A23-SH 4.95
1963 Coupe or convertible, with power windows, right . . . . C3SZ-63237A22-PW 95.95
1963 Coupe, with manual windows & remote mirror, left . . . . C3SZ-63237A23-MWRM 95.95
1963 Convertible, with manual windows, without remote mirror, left . . . . . C3SZ-76237A23-MW 95.95
1963 Convertible, with manual windows, with remote mirror, left . . . . C3SZ-76237A23-MWRM 95.95
1963 Coupe, with power windows, without remote mirror, left . . . . . C3SZ-63237A23-PW 95.95
1963 Coupe, with power windows, with remote mirror, left . . . . C3SZ-63237A23-PWRM 95.95
1963 Convertible, with power windows, without remote mirror, left . . . . . C3SZ-76237A23-PW 95.95
1963 Convertible, with power windows, with remote mirror, left . . . . C3SZ-76237A23-PWRM 95.95





## Quarter Trim Panels

1958 & 59 quarter trim panels are made with Bison grain vinyl to match our seat covers. For 1960, quarter trim panels have horizontal & vertical embossed lines with buttons to match vinyl seats. 1960 quarter trim panels are made with Pebble grain vinyl to match our seat covers.



- |       |                                       |               |            |
|-------|---------------------------------------|---------------|------------|
| 58-59 | White #2, coupe & convertible (shown) | B8S-31012-WHT | 49.95 pair |
| 1959  | Light blue #10, coupe & convertible   | B8S-31012-LBL | 49.95 pair |



- |       |                                                                      |                  |             |
|-------|----------------------------------------------------------------------|------------------|-------------|
| 1960  | White #13, coupe                                                     | COSZ-6331012-WHT | 132.95 pair |
| 1960  | Light blue #16, coupe                                                | COSZ-6331012-LBL | 132.95 pair |
| 1960  | Light turquoise #18, coupe                                           | COSZ-6331012-LTQ | 132.95 pair |
| 1960  | Light green #20, coupe                                               | COSZ-6331012-LGR | 132.95 pair |
| 1960  | Light beige #22, coupe                                               | COSZ-6331012-LBG | 132.95 pair |
| 1960  | White #13, convertible                                               | COSZ-7631012-WHT | 132.95 pair |
| 1960  | Light blue #16, convertible                                          | COSZ-7631012-LBL | 132.95 pair |
| 1960  | Light turquoise #18, convertible                                     | COSZ-7631012-LTQ | 132.95 pair |
| 1960  | Light green #20, convertible                                         | COSZ-7631012-LGR | 132.95 pair |
| 1960  | Light beige #22, convertible                                         | COSZ-7631012-LBG | 132.95 pair |
| 61-63 | Rear quarter aluminum trim, right                                    | C1SB-63310A02-A  | 28.95       |
| 61-63 | Rear quarter aluminum trim, left                                     | C1SB-63310A03-A  | 28.95       |
| 64-66 | Rear quarter upper trim caps, paint to match body color, convertible | C4SZ-7631490     | 33.95 pair  |

## Rear Armrest Covers

Armrest covers are just about always split & cracked with age, with the grain pattern worn smooth from years of constant contact. Put brand new armrests & covers on your door panels for that brand-new-car look, as well as comfort!



1958 & 59 rear armrest covers are made with Bison grain vinyl, the same as our seat covers.

- |      |                           |               |            |
|------|---------------------------|---------------|------------|
| 1958 | Black # 1                 | B8S-31600-BLK | 49.95 pair |
| 1958 | Red #8                    | B8S-31600-RED | 49.95 pair |
| 1958 | Blue #4                   | B8S-31600-BLU | 49.95 pair |
| 1958 | Gulfstream #5             | B8S-31600-TUR | 49.95 pair |
| 1958 | Green #6                  | B8S-31600-GRN | 49.95 pair |
| 1958 | Palomino #7               | B8S-31600-PAL | 49.95 pair |
| 1959 | Black # 1                 | B9S-31600-BLK | 49.95 pair |
| 1959 | Red #8                    | B9S-31600-RED | 49.95 pair |
| 1959 | Dark blue #9              | B9S-31600-DBL | 49.95 pair |
| 1959 | Turquoise #11             | B9S-31600-TUR | 49.95 pair |
| 1959 | Green #6                  | B9S-31600-GRN | 49.95 pair |
| 1959 | Hickory tan (Palomino) #7 | B9S-31600-TAN | 49.95 pair |

1960 rear armrest covers are made with Pebble grain vinyl to match our seat covers.

- |      |                    |                |            |
|------|--------------------|----------------|------------|
| 1960 | Black #12          | COSZ-31600-BLK | 49.95 pair |
| 1960 | Red #14            | COSZ-31600-RED | 49.95 pair |
| 1960 | Dark blue #15      | COSZ-31600-DBL | 49.95 pair |
| 1960 | Dark turquoise #17 | COSZ-31600-DTQ | 49.95 pair |
| 1960 | Dark green #19     | COSZ-31600-DGR | 49.95 pair |
| 1960 | Dark beige #21     | COSZ-31600-DBE | 49.95 pair |

## Headliners

Perforated vinyl headliners were used from 1958 to 1965. In 1966, Crater (or Moonskin) vinyl was used on cars with a roof console. Cars without the roof console continued to use perforated vinyl headliners.

Think about the last time you cleaned the headliner in a car ... it's the most neglected piece of trim in any vehicle. We have great prices on original type headliners in black, white or bone. Compare & we think you'll see—our headliners are the best value around! Sorry, no instructions are included.

- |       |                           |                  |       |
|-------|---------------------------|------------------|-------|
| 58-60 | White                     | B8S-6351916-WHT  | 56.95 |
| 58-60 | Bone, for beige interiors | B8S-6351916-BON  | 56.95 |
| 58-60 | Black                     | B8S-6351916-BLK  | 56.95 |
| 61-63 | White                     | C1SZ-6351916-WHT | 47.95 |
| 61-63 | Bone                      | C1SZ-6351916-BON | 47.95 |
| 61-63 | Black                     | C1SZ-6351916-BLK | 47.95 |
| 64-66 | White                     | C4SZ-6351916-WHT | 56.95 |
| 64-66 | Bone                      | C4SZ-6351916-BON | 56.95 |
| 64-66 | Black                     | C4SZ-6351916-BLK | 56.95 |

### Headliner Color Sample Card

- |       |                   |         |      |
|-------|-------------------|---------|------|
| 58-66 | Color sample card | SAMPLE2 | FREE |
|-------|-------------------|---------|------|

## Headliner Installation Tools



- |     |                                                                                                                |            |       |
|-----|----------------------------------------------------------------------------------------------------------------|------------|-------|
| ALL | Headliner tool, economy model                                                                                  | TOOL-7672  | 10.95 |
|     | <i>For a better grip, try our deluxe model with a wooden handle—it's just like the tool professionals use!</i> |            |       |
| ALL | Headliner tool, deluxe model                                                                                   | TOOL-13575 | 22.95 |



- |     |                                                                                                                      |         |       |
|-----|----------------------------------------------------------------------------------------------------------------------|---------|-------|
| ALL | Vinyl adhesive, 18.1 oz. spray can, 3M brand                                                                         | RSP29 * | 14.75 |
|     | * <b>HAZARDOUS MATERIAL</b> can only be shipped by ground/surface within the U.S. because of government regulations. |         |       |

## Coat Hook Kit



- |       |                                                                                  |                |          |
|-------|----------------------------------------------------------------------------------|----------------|----------|
| 58-60 | Coat hook kit                                                                    | B2A-7029025-KT | 8.95 kit |
| 64-66 | Coat hook installation set, 2 flat-head Phillips screws, 1 set does 2 coat hooks | 2HK81B         | 2.95 set |



### Insulation & Sound Deadener

If you are replacing your carpet, now is the best time to install superior firewall insulation. We carry everything you'll need. Our big 48" x 72" sheet is a full 5/16" thick & is rated to R18 (meaning it resists heat up to 700°). It's constructed of jute fiber with a space age reflective foil bonded to both sides. You can put it on the firewall, behind the kick panels or even on the trunk divider. It does the job of blocking intrusive road noise & keeping engine heat in the engine compartment where it belongs.



- ALL Firewall insulation, 48" x 72" x 5/16", cut to fit desired area . . . . . V700770X 32.00

For years, we have been selling the original Dynamat & can boast of hundreds of satisfied customers. We are now proud to offer the next generation of Dynamat sound deadeners, Xtreme. Xtreme is a step up from the original formula & is Dynamat's best product at controlling vibration. It damps 4 times as much as the original Dynamat & as an added bonus, it weighs 50% less. It is available in conveniently sized 18" x 32" sheets & with peel & stick application; it goes on quickly & easily. Do yourself a favor & order some today!

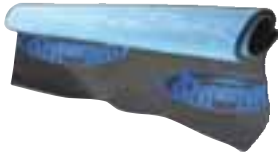

- ALL  Dynamat Xtreme, each piece is 18" x 32" (as required) . . . . . DYNAMAT-0433 29.95

We suggest RSP49, great for filling in the gaps between sound deadener sheets or firewall insulation.



- ALL Under coat, 17 oz. spray, rubberized formula protects, seals & insulates . . . . . RSP49 \* 9.95
- Ever wonder what that stuff is on the back of your carpet? It's called jute fiber & it provides a cushion underneath your carpet as well as sound insulation. We have it available in 36" x 72" sheets that are 5/16" thick. You cut the size you need for the area you want to put it in.



- ALL Synthetic jute fiber, 36" x 72" x 5/16", cut to fit . . . . . B13000 15.95

**See Hardware on page 240 for complete screw kits for the interior.**

### Sun Visors

The sun visors listed below have been reproduced in the correct grain vinyl. All original embossments have been faithfully recreated. Sorry, no other Thunderbird sun visors are currently available.

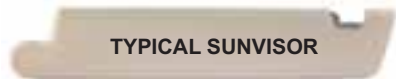

TYPICAL SUNVISOR

- 58-59 White bison . . . . . B8S-6304104-WHT 134.95 pair
- 1960 White pebble . . . . . COSB-6304104-WHT 119.95 pair
- 1960 Black pebble . . . . . COSB-6304104-BLK 119.95 pair
- 1960 Red pebble . . . . . COSB-6304104-RED 119.95 pair
- 1960 Dark blue pebble . . . . . COSB-6304104-DBL 119.95 pair
- 1960 Dark turquoise pebble . . . . . COSB-6304104-DTG 119.95 pair
- 1960 Dark green pebble . . . . . COSB-6304104-DGR 119.95 pair
- 1960 Light beige pebble . . . . . COSB-6304104-LBG 119.95 pair

### Sun Visor Clips



- 58-60 Chrome, includes mounting screws & lock-washers (2 required) (above left) . . . . . B8S-7604131-A 16.95
- 61-63 Chrome, includes mounting screws & lock-washers (above right) . C3SZ-6304131-A 19.95
- 1966 Chrome, fits into overhead console, right . . . . . C6SZ-6304132-A 22.95
- 1966 Chrome, fits into overhead console, left . . . . . C6SZ-6304133-A 22.95

### Sun Visor Arm & Bracket Assemblies



- 58-60 Die cast, chrome, right, fits all body styles (above left) . . . . . B8S-6304144-A 49.95
- 58-60 Die cast, chrome, left, fits all body styles . . . . . B8S-6304145-A 49.95
- 61-63 Die cast, chrome, right, fits all body styles (above right) . . . . C1SB-6304144-B 49.95
- 61-63 Die cast, chrome, left, fits all body styles . . . . . C1SB-6304145-B 49.95



- 64-66 Die cast, chrome, coupe (above left) . . . . . C4SZ-6304144-PR 39.95 pair
- 64-66 Die cast, chrome, right, convertible (above right) . . . . C4SZ-7604144-A 49.95
- 64-66 Die cast, chrome, left, convertible . . . . . C4SZ-7604145-A 49.95

### Sun Visor Anchor Pins (2 required)

- 61-63 Chrome, does not include tip . . C3DZ-7604114-B 5.95
- 64-65 Chrome, does not include tip, all body styles . . . . . C4SZ-6304114-A 2.95
- 1966 Chrome, does not include tip, body styles 63A & 76 only . . . . C4SZ-6304114-A 2.95



### Sun Visor Tip



- 61-66 Rubber, all body styles . . . . . D1DZ-6204115-PR 1.95 pair
- 61-63 Sun visor bracket screw set, 8 oval-head Phillips screws, 1 set does both sides . 2HK86A 5.95 set



## Carpeted Floor Mats

Please see listing on the next page for carpet color choices. Complete the show car look of your interior with our carpeted floor mats, now available with an embroidered logo. Choose from 7 different designs that match the emblems used on these great cars. Call us & we can get a set to you in no time at all!

ALL Carpeted floor mats, 4-piece set, plain, without any logo ..... 8880-PLAIN 74.95 set

Logo mats are not returnable!

ALL Carpeted floor mats, 4-piece set, with your choice of 6 embroidered logo's, please include the number listed next to the logo. .... 8880-LOGO 119.95 set



148



111



80



116



113



112



Unsure of the color?  
Order SAMPLE2, it's free!

## Rubber Floor Mats

These reproduction floor mats look just like the floor mats Ford provided back when your Bird was brand new. Made of heavy-weight rubber, they feature the T-Bird logo at the top. For 58-63, the word "Thunderbird" in script is also written across the mat.

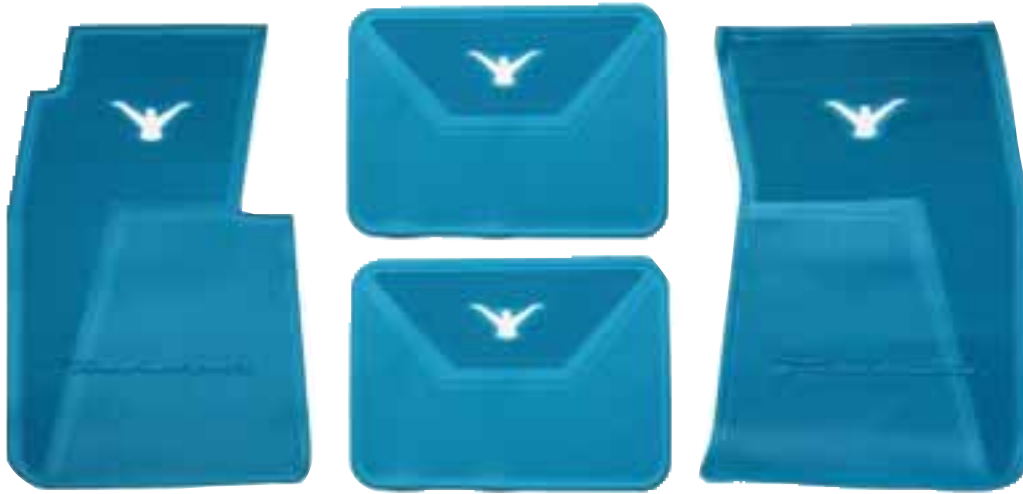

### 2-piece Pairs, Front Only

58-60	Black with white T-bird	13086-PRB	79.95 pair
58-60	Red with white T-bird.	13086-PRR	79.95 pair
58-60	Medium blue with white T-bird	13086-PRMB	79.95 pair
58-60	Medium green with white T-bird	13086-PRA	79.95 pair
58-60	Willow green with white T-Bird	13086-PRWG	79.95 pair

### 4-piece Sets, Front & Rear

58-60	Black with white T-bird	13086-SETB	104.95 set
58-60	Red with white T-bird.	13086-SETR	104.95 set
58-60	Medium blue with white T-bird	13086-SETMB	104.95 set
58-60	Medium green with white T-bird (shown)	13086-SETA	104.95 set
58-60	Willow green with white T-Bird	13086-SETWG	104.95 set
61-63	Medium green with white T-bird	C1SZ-6313086-GRN	83.95 set
61-63	Black with white T-bird	C1SZ-6313086-BLK	83.95 set
61-63	Blue with white T-bird	C1SZ-6313086-BLU	83.95 set
61-63	Red with white T-bird.	C1SZ-6313086-RED	83.95 set
64-66	Medium green	C4SZ-6313086-AQU	83.95 set
64-66	Black	C4SZ-6313086-BLK	83.95 set
64-66	Blue	C4SZ-6313086-BLU	83.95 set
64-66	Burgundy	C4SZ-6313086-BUR	83.95 set
64-66	Red	C4SZ-6313086-RED	83.95 set





### Carpet Sets

All of our carpets are made of top quality materials throughout. Using the finest loop pile that the factory specified they feature serge-bound edges, bonded underlay padding, correct heel & toe pads & a dimmer switch ring. Carpets for 1958 thru 1963 are cut & sewn as original with 1958 thru 1960 a 10-piece set & 1961 thru 1963 an 11-piece set. Beginning in 1964 all of our carpets are molded to the shape of your floor with a separate front & rear piece, just like it was from the factory.

Beginning in 1964, your Thunderbird might have had carpet on the lower part of the door panel. MAC's door carpet sets include the vinyl. We recommended that door & floor carpets be purchased at the same time to assure a good color match.

- 58-66 Carpet set, choose from our list below of 58-60, 61-63 & 64-66 carpet colors . . . . . 5866-BIRDCARPET 164.95 set
- 58-66 One yard of loop pile carpet in the color of your choice, 72" wide . . . CARPETYARD 44.95 yard
- 64-66 Door carpet set, choose from our list of colors below for 1964-1966 carpet sets . . 6466-DOORCARPET 45.95 set

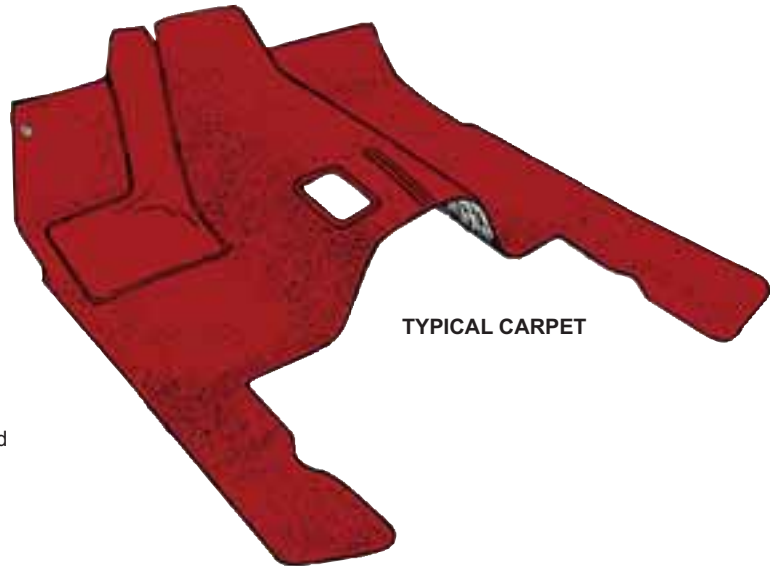

### When ordering floor carpets,

**we will need the following information:**

1. Year, make & model of your car
2. Body style of your car (found on patent/warranty plate, driver's door).
3. Front seat type (bench/bucket, power or not)
4. Console between front seats?
5. Transmission type (manual or automatic, floor shift or column)
6. Color—see "Sample Cards" below



#### Color Sample Card

ALL Color sample card for carpets . . . . . SAMPLE2 FREE

1958-1960		1958-1963			1958-1966			
Dark Saddle #14	Dark Brown #32	Blue Green #41	Black #11	Red #12	Fawn (sandlewood) #23	Aqua #24	Bright Blue #31	
1961-1966				1964-1966				
Emberglo #25	Rose Beige #33	Medium Saddle #35	Silver Mink #42	Maroon #21	Ivy Gold #55	Dark Blue #34		



Why does a convertible top move slowly & weakly as the car gets old? Why doesn't it snap tightly in place anymore? Time & usage wear down the critical components that operate your top, that's why!

Any hydraulic system requires maintenance to keep working properly; especially when the components are subjected to years of weather, use & neglect ... not to mention temperature extremes. Old tops with stiffened vinyl fabric are simply less pliable & resist folding. Corrosion & the degrading of fluids also contribute to the weakening of the system.

The best plan is to replace the hydraulic pump, motor, cylinders & all hoses with brand new top quality replacements from MAC's Antique Auto Parts. You'll love the way your hydraulic system springs to life & quickly raises or lowers your top at the push of a button. While you're working on the mechanics of your convertible top, don't forget the vital detail components, like top arm pads, a new rubber weather-stripping kit & more.

Call the Ford restoration experts at MAC's Antique Auto Parts & let them help you make good decisions about the items you'll need to get that convertible back in "tip-top" shape!

## Convertible Top Latch (2 required)



64-66 **NEW** Latch assembly, includes chrome handle & "J" hook . . . . . C4SZ-7650508-ASY 99.95

## Convertible Top Latch Handle & "J" Hook

If your Bird is like many that we've seen, the ears are broken off the top latch handle or the "J" part of the "J" hook is missing. This makes latching your top down tightly impossible. We carry brand new reproductions of these two items so check yours out & if they need replacing, give us a call!



64-66 Handle, chrome (2 required) . . . . . C4SZ-7650508-A 24.95  
64-66 "J" hook, chrome (2 required) . . . . . C4SZ-7650636-A 9.95

## Convertible Top Switch, Handle & Escutcheon Plate

61-62 Major convertible top switch . . . . . C1SF-15668-A 36.95



1960 Switch handle, chrome, "TOP" embossed in black . . . . . FDK-15674-A 19.95  
61-62 Escutcheon plate for convertible top switch, chromed plastic . . . . . C1SB-14A183-A 11.95

## Convertible Top Limit Switch



59-63 . . . . . B9SF-15A672 166.95

## Convertible Top Relays

All 1961 thru 1966 T-Birds use 8 relays to control the various functions required to raise & lower the top. The 1960 T-Bird used 10 relays! A bad relay will bring the whole process to a grinding halt. We now carry reproduction relays to keep your top in working order. Our "Top Adjustment & Repair Manual" will help you troubleshoot & pinpoint problems – see our **Book Section**.



1960 3 contact posts, right . . . . . COSF-15672-A 59.95  
1960 3 contact posts, left (not shown) . . . . . COSF-15672-C 59.95  
1960 **NEW** 2 contact posts, stamping # COSF-15672-D (8 required) . . . . . COSF-15672-D 56.95  
61-63 2 contact posts, stamping # COSF-15672-D (2 required) . . . . . COSF-15672-D 56.95



61-63 3 contact posts, stamping # C1SF-15672-A (6 required) . . . . . C1SF-15672-A 55.95  
64-66 3 contact posts, stamping # C2VB-15672-A (4 required) . . . . . C2VY-15672-A 56.95  
64-66 3 contact posts, stamping # C1SF-15672-A (4 required) . . . . . C1SF-15672-A 55.95

## Top Control Relay



63-66 Located under the hood on the firewall . . . . . C3VY-14512-D 55.95

## Convertible Cowl Braces

64-66 Right & left . . . . . C4SZ-16298 78.95 pair



Convertible Top Motor & Pump Assembly



58-66 ..... COSB-76533A00-A 318.95

Upper Back Panel Gear Boxes

Also called the flip lid gear housing.



60-63 ..... C1SB-7653310 184.95
64-66 ..... C4SB-7653310 184.95

Coupler for Flip Lid Motor

60-66 Coupler, the connector between the flip lid motor & the flip lid mechanism ..... BAD-5146593-A 14.95

Convertible Top Hose Sets

All fittings are included & installed on hose set.



1960 5-piece set ..... COSB-7653456-ST 279.95 set
61-62 5-piece set, 1961 & early 1962, 2-1/4" diameter trunk lid lift cylinders ..... C1SZ-7653456-ST 279.95 set
62-63 5-piece set, 1963 & late 1962, 1-3/4" diameter trunk lid lift cylinders ..... C2SZ-7653456-ST 279.95 set
64-66 5-piece set ..... C4SZ-7653456-ST 279.95 set

Trunk Lid Lift Cylinders (2 required)

1960 ..... COSB-76406A10-A 170.95
61-62 2-1/4" diameter, used thru early 1962 ..... C1SB-76406A10-A 170.95
62-63 1-3/4" diameter, from late 1962 to 1963 ..... C3SZ-76406A10-A 170.95
1964 ..... C4SZ-76406A10-A 170.95
65-66 ..... C5SZ-76406A10-A 170.95

Top Rear Side Rail to Lift Cylinder Bushing (4 required)



64-66 Nylon, convertible ..... C3AZ-7650412-A 4.95

Package Tray Seal

58-60 63" long ..... B8S-7646740 14.95

Convertible Top Lift Cylinders

A bad cylinder can ruin your day! If one side works better than the other you can bend or break your top frame. Don't take a chance install 2 new cylinders & be free from worry.



58-60 Right ..... B9SB-7650600-R 170.95
58-60 Left ..... B9SB-7650600-L 170.95
61-62 Right or left (2 required) ..... C1SB-7650600 170.95
1963 Right or left (2 required) ..... C3SZ-7650600 170.95
64-66 Right or left (2 required) ..... C4SZ-7650600 170.95

Convertible Trunk Weatherstrip Kits

Each convertible trunk weatherstrip kit contains everything to seal your convertible trunk. The correct type adhesive to install.

58-60 4-piece kit ..... B8S-7643720-KT 89.95 kit
61-63 4-piece kit ..... C1SZ-7643720-KT 79.95 kit
64-65 23-piece kit, before 2-15-65, splash shield not included. . . C4SZ-7643720-KT 269.95 kit
65-66 19-piece kit, from 2-15-65, splash shield not included. . . C6SZ-7643720-KT 267.95 kit

Trunk Drain Trough

61-66 Plastic, fits in front corner of trunk opening ..... C1SZ-6345118-PR 33.95 pair

Convertible Roof Rail Seal Kits

When you wash your T-Bird does water run down the inside of your windows? If that's the case your roof rail seals need to be replaced. Roof rail weatherstripping keeps wind, noise & rain out of your classic car, for a quieter more comfortable experience. Roof rail weatherstripping is located at the roof edge where your side windows roll up for a tight seal. Aged & cracked seals can ruin the appearance of your car.

MAC's carries the finest quality seals made today—from the correctly shaped extrusions, to the permanently bonded corners & pre-installed mounting studs, our seals are the best. Keep the elements where they belong, outside!

1958-1963 sets do not include the convertible top arm pads. These items are listed separately on the next page.

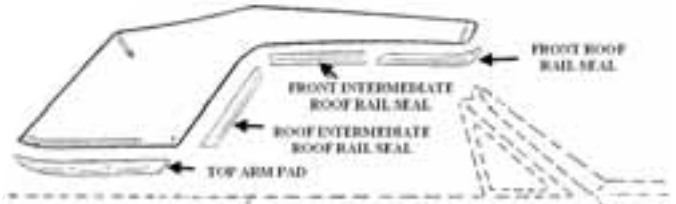

58-60 6 pieces ..... B8S-7651222-KT 295.95 kit
61-63 7 pieces, includes front header seal & "T"-bolts ..... C1SZ-7651222-KT 224.95 kit
64-66 7 pieces, includes top arm pads & header seal ..... C4SZ-7651222-KT 207.95 kit



58-66 NEW T-bolt for convertible roof rail seals (as required) ..... 35222-S 1.95
64-66 Roof rail weatherstrip screw set, 24 round washer-head screws, 1 set does both sides ..... 2HK81A 37.95 set
ALL Black, 3M brand, 5 oz. tube, perfect for door & roof rails seals ..... RSP28 8.75



# CONVERTIBLE PARTS



## Convertible Top Outer Front Seals

This seal attaches to the outer front edge of the top.

- 61-66 Black, rubber . . . . . C1SZ-7651325-BLK 47.95
- 61-66 White, rubber . . . . . C1SZ-7651325-WHT 47.95
- 61-66 Beige, rubber . . . . . C1SZ-7651325-BGE 47.95

## Top Arm Seal

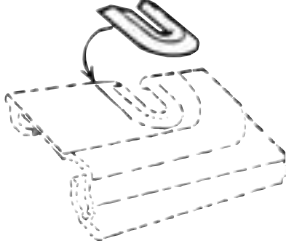

- 64-66 Attaches beneath package tray, top arm goes thru this seal. . . . . C4SZ-76465A10-PR 9.95 pair

## Convertible Top Arm Pads

Convertible top arm pads attach to the bottom of the top arms. When your top is down they rest on the painted surface of the body. These are rubber pads with a heavy steel core. Top arm pads are included in 1964-1966 convertible roof rail seal kits (listed on previous page); for 1958-1963, the pads are only sold separately.



- 58-60 Rubber . . . . . B8S-7651566-PR 88.95 pair
- 61-63 Rubber (not shown) . . . . . C1SZ-7651566-PR 79.95 pair
- 64-66 Rubber, see note above . . . . . C4SZ-7651566-PR 60.95 pair

## Convertible Front Header Seals

We suggest that you use RSP28 on all of these seals that attach to the underside of the convertible top.



- 58-60 "U" shaped channel, rubber with a metal core, attaches to front of top . . . . . B8S-7651330-A 79.95
- 58-60 Rubber, attaches to front of #1 top bow . . . . . B8S-7651338-A 17.95
- 61-63 Rubber, attaches to #1 top bow, included in roof rail seal kit C1SZ-7651222-KT . . . . . C1SZ-76514A28-A 38.95

## Convertible Top Pads



- 58-63 Convertible top pads, 65" long, black, install front to back along bow curves . UNIV-PAD 36.95 pair
- 64-66 Convertible top specially-tapered pads, black . . . . . 2042-PAD 49.95 pair

## Tack Strip (as required)

This premium quality, long lasting hard rubber material replaces the original cardboard tack strip. No more crumbling & flaking, this product will outlast your car. We sell it by the foot, so please measure how much you will need before calling in your order.



- 58-66 1/2" wide x 3/8" thick . . . . . TACKSTRIP 1.00 foot
- 58-66 **NEW** 5/8" wide x 1/8" thick . . . . TACKSTRIP-F 1.00 foot

## Convertible Top Kits

We are proud to offer the best convertible tops that money can buy! Each is constructed using only premium quality 32-36 oz. vinyl & features a zippered-in clear plastic back window, matching vinyl bow covering, wire-on trim, tips, screws & is available in either white or black. Pads are not included but are available separately. Our tops are covered for 6 years on materials & workmanship\* so your satisfaction is guaranteed!

\* Because of the difficulty of installation, the warranty is void if the top is not professionally installed.



You will probably need to replace your top pads when installing your new top. Select from our choices below.

- 58-60 Black-black #CV21 . . . . . 2040-BLK 289.95 kit
- 58-60 White-black #CV22 . . . . . 2040-WHT 289.95 kit
- 61-63 Black-black #CV21 . . . . . 2041-BLK 289.95 kit
- 61-63 White-black #CV22 . . . . . 2041-WHT 289.95 kit
- 64-66 Black-black #CV21 . . . . . 2042-BLK 289.95 kit
- 64-66 White-black #CV22 . . . . . 2042-WHT 289.95 kit
- 58-66 Convertible top color choices for Thunderbird . . . . . SAMPLE2 **FREE**

## Tonneau Cover Parts

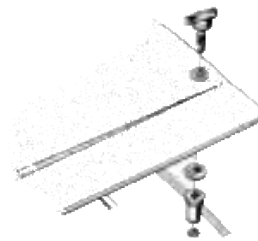

- 58-66 Wing screw & retainer, chrome (2 required) . . . . . C2SZ-76501A36-A 14.95
- 58-66 Footman's loop, chrome . . . . . C2SZ-7654810-A 11.95
- 58-66 Center clamp for footman's loop. C2SZ-76501A14-A 8.95
- 64-66 Tonneau cover moulding corner . . . C4SZ-501A64 8.95



- 62-63 Tonneau cover ornament, Roadster emblem, one used on tonneau cover & one on each fender, chrome with red, white, blue & black paint (3 required) . . . . . C2SZ-16228-A 25.95

You will need 3 of the barrel clips below to install each ornament.



- 58-64 Barrel clip, medium size (as required) . . . 375890-S 0.60



## Trunk Light Kit



- 58-66 Trunk light kit, coupe, a reproduction of a great Ford over the counter accessory . . . . . C2RZ-15A700-A 19.95 kit

## Spare Tire Hold-Down Parts



- 58-59 Plate . . . . . C5ZZ-1424-A 3.95
- 62-66 Plate, used with wire wheel. . . . . C5ZZ-1424-A 3.95



- 58-63 Hold-down, wing bolt. . . . . B7A-1448-A 14.95
- 64-66 Hold-down, "J" hook . . . . . B5A-1448-B 4.95
- 64-66 Hold-down, wing nut . . . . . B9AZ-1462-A 2.95

## Bumper Jack Pad (2 required)

- 64-66 For bumper jack support bracket . . . C4SZ-17040 2.95

## Trunk Lid Bumper (2 required)



- 58-59 Rubber, convertible. . . . . B7A-16993-A 1.95

## Trunk Lid to Rear Body Panel Seals & Clip

*Clips not included, see below.*

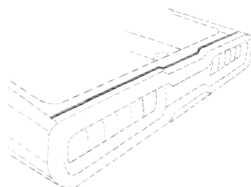

- 64-66 Black, pre-punched holes, coupe. . . . . C4SZ-63403C50-BLK 22.95
- 64-66 Gray, pre-punched holes, coupe. . . . . C4SZ-63403C50-GRY 22.95



- 64-66 Rear body panel seal clips (16 required) . . . . . C4SZ-6340351-A 1.95

## Trunk Drain Hose



- 64-66 Coupe . . . . . C4SZ-63424A62-PR 58.95 pair

## Trunk Lid Seals



- 58-63 Trunk lid seal, coupe . . . . . COMB-6443720-C 19.95
- 64-66 Trunk lid seal, coupe. . . . . C3AZ-6243720-A 21.95

*All of the trunk seals on this page need adhesive to attach them to your car. Our RSP28 is just the ticket to do the job!*

- ALL 3M brand door seal & felt glass channel adhesive, black, 5 oz. tube, the perfect adhesive for attaching your trunk seals. . . . . RSP28 8.75



## Trunk Lock Cylinders & Keys



- 58-59 Includes 2 keys . . . . . B9A-6443505-A 36.95
- 58-59 **NEW** Trunk lock cylinder, with 2 reproduction Ford script keys, keyhole cover is not included. . . . . B9A-6443505-AF 41.95
- 1960 Includes 2 keys . . . . . COSB-6343505 31.95
- 61-63 Includes 2 keys . . . . . B9A-6443505-A 36.95
- 61-63 **NEW** Trunk lock cylinder, with 2 reproduction Ford script keys, keyhole cover is not included. . . . . B9A-6443505-AF 41.95



- 1964 Includes 2 keys . . . . . C4AZ-6243505-C 33.95
- 65-66 Includes 2 keys . . . . . C6AZ-7143505-B 33.95

## Trunk Lock Lever



- 1964 . . . . . C4SZ-6343358-A 16.95

## Trunk Lock Extension



- 61-63 Actuator from lock cylinder to latch, coupe. . . . . C3MY-6243283-B 18.95



## Trunk Lock Ornament Assemblies

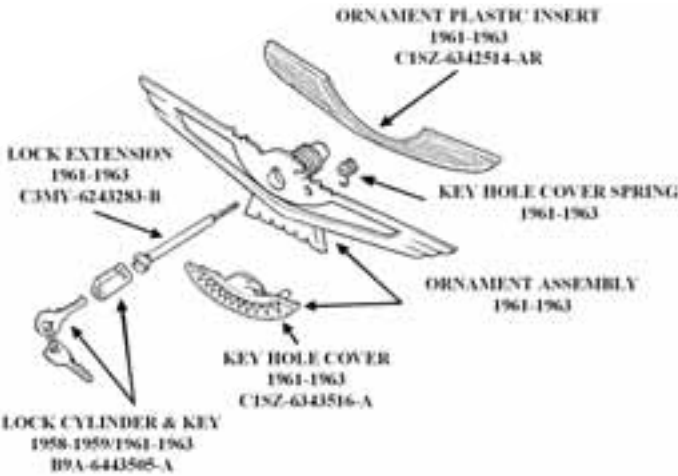

58-59	Chrome, includes base & cover, coupe.....	B8S-6343500-ASY	109.95
58-59	Chrome, includes base & cover, convertible.....	B8S-7643500-ASY	110.95
1960	Chrome, includes base & cover, coupe.....	COSB-6343500-ASY	104.95
1960	Chrome, includes base & cover, convertible.....	COSB-7643500-ASY	115.95
61-63	Chrome, includes base & cover, coupe.....	C1SZ-6343500-ASY	106.95
61-63	Chrome, includes base & cover, convertible.....	C1SZ-7643500-ASY	94.95
1964	Chrome, includes base, cover with insert & hinge..	C4SZ-6343500-ASY	86.95
65-66	Chrome, includes base, cover with insert & hinge..	C5SZ-6343500-ASY	89.95

## Trunk Hardware

61-63	Trunk hinge to lid hardware set, 4 faceted-flange-head black oxide finish bolts, 1 set does both sides. . . .	2HK83A	5.95 set
61-63	Trunk hinge to fender brace hardware set, 6 faceted-flange-head black oxide finish bolts, 1 set does both sides. . . .	2HK83C	7.95 set
61-63	Trunk latch hardware set, 3 hex-head bolts & 3 flat washers . . . . .	2HK83E	2.95 set
61-63	Trunk latch catch hardware set, 2 hex-head bolts & 2 flat washers . . . . .	2HK83G	2.95 set
61-63	Trunk lock retainer hardware set, 2 stamped nuts (1 notch) . . . . .	2HK83J	2.95 set
64-66	Trunk hinge to lid hardware set, 4 hex-head bolts (black oxide finish) with captive washers & 4 external-tooth lock-washers, 1 set does both sides . . . . .	2HK83B	5.95 set
64-66	Trunk hinge to body hardware set, 6 faceted-flange-head black oxide finish bolts & 6 external-tooth lock-washers, 1 set does both sides . . . . .	2HK83D	12.95 set
64-66	Trunk latch hardware set, 2 hex-head bolts with captive flat washers & 2 external-tooth lock-washers . . . . .	2HK83F	2.95 set
64-66	Trunk latch catch hardware set, 2 black oxide finish hex-head bolts with captive flat washers & 2 external-tooth lock-washers . . . . .	2HK83H	3.95 set
64-66	Trunk lock assembly hardware set, 2 pan-head Phillips screws & 2 black oxide finish nuts with captive washers. . . . .	2HK83K	4.95 set

## Trunk Lock Ornament Parts

### Ornament Insert



61-63	Plastic, turquoise.....	C1SZ-6342514-AR	18.95
-------	-------------------------	-----------------	-------

### Ornament Base Gaskets



1964	<b>NEW</b> Rubber . . . . .	C4SZ-6343625-A	1.95
65-66	<b>NEW</b> Rubber . . . . .	C5SZ-6343625-A	1.95

### Key Hole Covers & Parts

58-59	Cover, chrome, coupe.....	B9SB-6343516	20.95
58-59	Cover, chrome, convertible.....	B9SB-7643516	22.95



58-59	<b>NEW</b> Spring . . . . .	B8S-6343567-A	1.95
58-59	<b>NEW</b> Rod, for above spring . . . . .	B8S-6343239-A	1.95



1960	Cover, chrome, includes new spring & attaching hardware, coupe (above left) . . . . .	COSB-6343516-A	39.95
1960	Cover, chrome, convertible . . . . .	COSB-7643516	35.95
1960	Spring & retainer kit, includes 2 springs & 1 retainer, coupe (above right) . . . . .	COSZ-6343569-KT	8.95 kit
61-63	Cover, chrome with black & white paint, coupe. . . . .	C1SZ-6343516-A	43.95
61-63	Cover, chrome, convertible . . . . .	C1SB-7643516-B	32.95
61-63	Spring, coupe . . . . .	B9A-6443567-A	2.95
1964	Cover, chrome with unpainted steel insert, coupe. . . . .	C4SZ-6343603-A	47.95
65-66	Cover, chrome with unpainted steel insert, coupe. . . . .	C5SZ-6343603-A	47.95



65-66	Cover insert, primed steel with stud attached, includes nut & lock washer . . . . .	C5SZ-6343514-A	11.95
-------	-------------------------------------------------------------------------------------	----------------	-------





### Trunk Interiors

Our standard trunk interiors are made of fleece backed vinyl that is die-cut to the original size & shape. These sets include the mat, all the boards & curtain in the correct print for each year. They do not include the spare tire cover. Spare tire covers are available in a separate listing, below.

**OS** All trunk interiors are oversized & require additional shipping charges. **\$130.95**

#### Hardtop

- 58-59 #121 . . . B8S-6345456-A
- 1960 #108 . COSB-6345456-A
- 1961 #108 . . C1SZ-6345456-A
- 62-63 #119 . . C2SZ-6345456-A
- 1964 #119 . . C4SZ-6345456-A
- 1965 #124 . . C5SZ-6345456-A
- 1966 #126\* . C6SZ-6345456-A

#### Convertible

- 58-59 #121 . . . B8S-7645456-A
- 1960 #108 . COSB-7645456-A
- 1961 #108 . . C1SZ-7645456-A
- 62-63 #119 . . C2SZ-7645456-A
- 1964 #119 . . C4SZ-7645456-A
- 1965 #124 . . C5SZ-7645456-A
- 1966 #126\* . C6SZ-7645456-A

Originally, a material called Burtex was used for all trunk interiors in 1958 thru 1966. Unavailable for a long period, it has recently been reproduced & we are proud to announce that Concours correct trunk interiors are now available. Included are the floor mat & all the covered side boards. So for that extra touch of authenticity, install a set of our reproduction Burtex trunk mats today!

58-59	<b>NEW</b> Hardtop,	pattern # 121 . . . . . B8S-6345456-B	189.95
58-59	<b>NEW</b> Convertible,	pattern # 121 . . . . . B8S-7645456-B	189.95
1960	<b>NEW</b> Hardtop,	pattern # 108 . . . . . COSB-6345456-B	189.95
1960	<b>NEW</b> Convertible,	pattern # 108 . . . . . COSB-7645456-B	189.95
1961	<b>NEW</b> Hardtop,	pattern # 108 . . . . . C1SZ-6345456-B	189.95
1961	<b>NEW</b> Convertible,	pattern # 108 . . . . . C1SZ-7645456-B	189.95
62-63	<b>NEW</b> Hardtop,	pattern # 119 . . . . . C2SZ-6345456-B	189.95
62-63	<b>NEW</b> Convertible,	pattern # 119 . . . . . C2SZ-7645456-B	189.95
1964	<b>NEW</b> Hardtop,	pattern # 119 . . . . . C4SZ-6345456-B	189.95
1964	<b>NEW</b> Convertible,	pattern # 119 . . . . . C4SZ-7645456-B	189.95
1965	<b>NEW</b> Hardtop,	pattern # 124 . . . . . C5SZ-6345456-B	189.95
1965	<b>NEW</b> Convertible,	pattern # 124 . . . . . C5SZ-7645456-B	189.95
1966	<b>NEW</b> Hardtop,	pattern # 126 * . . . . . C6SZ-6345456-B	189.95
1966	<b>NEW</b> Convertible,	pattern # 126 * . . . . . C6SZ-7645456-B	189.95

\* Some early 1966 models used the 1965 pattern, be sure to check yours before ordering.

### Trunk Interior Fasteners



58-60	Trunk interior fastener,	push-in button (34 required) . . . . . TF7	0.25
61-63	Trunk interior fastener,	twist-clasp on jack flap (3 required) . . . . . UF32	0.85

### Trunk Interior Print Patterns

\* Early 1966 Thunderbirds used 1965 pattern #124; the mid-year & late 1966 uses our pattern #126.

#### 1958-1959



#121- Original pattern: White striped houndstooth checks, squares over taupe background.

#### 1960-1961



#108- Original pattern: Black striped houndstooth checks, squares over taupe, white diagonal striped background.

#### 1962-1964



#119- Original pattern: Speckled with gray, black & white flecks.

#### 1965 & Early 1966



#124- Original pattern: White houndstooth checks over taupe background.

#### Mid & Late 1966

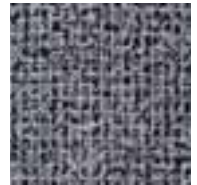

#126- Original pattern: White mesh over gray, black & white background.

### Spare Tire Covers

Our spare tire covers are made from the same material as our trunk interiors to assure a perfect match.



58-59	#121 . . . . . B8S-7645026-A	30.95
60-61	#108 . . . . . COSB-7645026-A	30.95
62-63	#119 . . . . . C2SZ-7645026-A	28.95
1964	#119 . . . . . C4SZ-7645026-A	28.95
1965	#124 . . . . . C5SZ-7645026-A	28.95
1966	#126 . . . . . C6SZ-7645026-A	28.95

In 1964, '65 & '66 a deluxe version of the spare tire cover was available. This cover included a lift up "door" over the wheel so you could stow jumper cables, gloves or some basic tools in the wheel & out of sight.

1964	Deluxe spare tire cover #119 . . . . . C4SZ-7645026-DLX	84.95
1965	Deluxe spare tire cover #124 . . . . . C5SZ-7645026-DLX	84.95
1966	Deluxe spare tire cover #126, some early '66s used the '65 pattern #124, be sure to check yours before you place your order . . . . . C6SZ-7645026-DLX	84.95



**MAC's Has The Best Radios & Best Of All,  
They Fit Your Factory Original Dash Opening!**

**USA-1 (CA1)**

**AM/FM Cassette Stereo Radio**

Our "standard" radio has more than just "standard" features. All of the features listed below plus 200 (4x50) watts of power. Add to that a chrome nosepiece & reproduction knobs & you have a radio that mimics the look of an older radio but plays like a contemporary high-powered one.

- Electronic Volume & Tuning Controls
- Auto Reverse
- 30 Station Presets (12 AM, 18 FM)
- Preset Memory Scan
- Power Antenna Lead
- Dual RCA Pre-out
- Front to Rear Fader
- Fast Forward & Rewind
- Seek & Scan
- Separate Bass & Treble
- Left & Right Balance Control
- Digital Clock



58-60	B8S-18806-CA1	222.95
58-60	B8S-18806-CA5	302.95
61-63	C1SZ-18806-CA1	222.95
61-63	C1SZ-18806-CA5	302.95
64-66	C4SZ-18806-CA1	222.95
64-66	C4SZ-18806-CA5	302.95
- Except 1966 with factory 8 track player		

**USA-5 (CA5) Features**

**AM/FM Cassette Stereo Radio.**

This radio is equipped with all the great features of the USA-1, plus it gets a bump in power, all the way up to 240 watts (4x60). In addition to that, it has the ability to control all the functions of our 10 disc CD player, USA-CD10, built right in. With the standard chrome nosepiece & chrome knobs this radio has the correct nostalgic look, but all the features you have become accustomed to in your modern car. Since it fits in your dash with no modifications at all & complete wiring directions are included, installation is easy & quick.

- Electronic Volume & Tuning Controls
- Auto Reverse
- 30 Station Presets (12 AM, 18 FM)
- Preset Memory Scan
- Power Antenna Lead
- Dual RCA Pre-out
- Front to Rear Fader
- Fast Forward & Rewind
- Seek & Scan
- Separate Bass & Treble
- Left & Right Balance Control
- CD changer control
- Digital Clock



**IMPORTANT INSTALLATION INFORMATION:**

All stereo equipment on these two pages require a 12 volt negative ground. Use of any other ground will destroy the radio. All of these radios are engineered to fit the original dash opening with no cutting, grinding or snipping; in fact, no modifications at all. All brackets, wiring & plugs, mounting hardware, a chrome bezel & original-looking chrome knobs along with installation instructions complete the package. All of our radios carry the manufacturer's 2 year limited warranty.

**Its standard features include:**

- \* 16 bit twin D/A converter
- \* 3 beam laser tracking
- \* 8x oversampling digital filter
- \* Advanced anti-vibration system
- \* Includes 16' of cable & all required mounting accessories



**PLAY CD'S IN YOUR CLASSIC CAR!**

This 10-disc CD/CD-R & CD-RW changer fits easily under your seat or in the trunk (11-3/8" wide x 2-7/8" high x 7-5/8" deep). It can be mounted horizontally or vertically. It's a simple one cable hook-up to a USA-5 & the radio controls all of the functions of the CD changer.

ALL USA-CD10 .....318.95

**\$UPER \$AVER**

Our USA-CD10 10-disc changer plus any of our USA-5 model radios.

ALL USA-5PK ..... 549.95



This SA-2 model is perfect for the show enthusiast. It allows you to leave the original radio in the dash & still get digital quality sound at the touch of a button. The main receiver is hidden under the seat, or wherever you choose to put it, while the remote controlled LCD screen is flush-mounted or swivel-mounted (optional) out of sight. Being only 3/4" thick allows you to mount it almost anywhere, such as the glove box, ashtray, sun visor or console.

# SECRET AUDIO

The SA-2 (140 watts, with radio frequency remote control) features: AM, FM stereo; 4-way fader; separate bass & treble; seek & scan tuning; flush remote mounted LCD bezel; optional swivel mount for LC control unit; dual RCA pre-out; 12 AM, 18 FM pre-set stations; CD changer controlled by wireless remote (not included) or remote mounted LCD panel.

ALL Includes flip-phone style remote . . . . .SA-2 254.95



**SA-2**

## Dual Front Speaker Assemblies

Since you don't want to cut holes in your doors or kick panels for speakers, we have the perfect solution: two speakers mounted to a bracket that will drop into your original dash speaker opening with no modifications at all! These assemblies are pre-wired to "plug-in" instantly to our radios. Want the best possible sound from your original speaker location? Upgrade to our dual voice coil speakers. They have 70% more cone area than our standard speakers & that gets you better bass response & 140-watt power handling capability. Each speaker has dual tweeters for crisp clear highs to make your favorite radio sound like it should. Give us a call & step up to dual voice coil speakers today.

### Dual Front Speaker Assemblies

58-60	18808-1007	30.95
61-63	18808-1012	30.95
64-66	18808-1001	30.95

### Dual Voice Coil Speaker Assemblies

61-63	18808-4012	55.95
64-66	18808-3001	47.95
64-66	18808-3003, rear seat type	47.95

## Dynamat® Sound Insulation

For years, we have been selling the original Dynamat & can boast hundreds of satisfied customers. We are now proud to offer the next generation of Dynamat sound deadeners: Xtreme. Xtreme is a step up from the original formula & is Dynamat's best product at controlling vibration. It damps 4 times as much as the original Dynamat &, as an added bonus, it weighs 50% less. It is available in conveniently sized 18" x 32" sheets & with peel & stick application; it goes on quickly & easily. Do yourself a favor & order some today!



ALL  Dynamat® Xtreme, each piece is 18" x 32" (as required) . . . . . DYNAMAT-0433 29.95



## Undercover Stealthspeakers

For those who want the deepest full bass sound, upgrade to our new Stealthspeaker 2. Able to handle up to 200 watts, these speakers utilize the same Piezo tweeter as the original Stealthspeaker for their clean & crisp highs, but now there are 2 in each enclosure. Add to that a larger 8" woofer & your favorite music will now be heard with an amazing new clarity & definition. If you want the best sound from a portable speaker, Stealthspeaker 2 is for you. Call & place your order today!

ALL	Stealthspeaker 2, 11" wide x 12.5" deep x 2.95" high	18808-6000	142.95 pair
ALL	Stealthspeaker, 11" wide x 8" deep x 2.875" high	18808-5000	119.95 pair



**18808-5000**



# RADIO



## Antenna Assembly & Base Pads

All antennas come complete with the wire from the radio to the antenna, base mounting pad & all attaching hardware. Installation instructions & templates are included, unless noted.

**NOTE:** 58-60 will require some trimming of the factory dash.

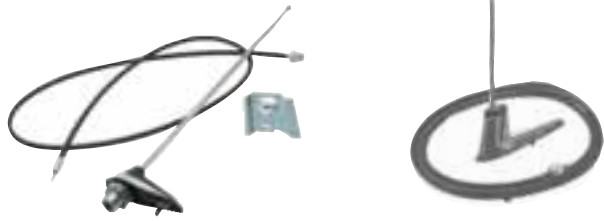

- |       |                                                                                                |                |       |
|-------|------------------------------------------------------------------------------------------------|----------------|-------|
| 58-60 | Assembly, front fender mount . . . . .                                                         | B8S-18813-C    | 60.95 |
| 58-66 | Assembly, rear trunk mount . . . . .                                                           | B7A-18813-A    | 88.95 |
| 61-63 | Assembly, rectangular base, front fender mount, no instructions or mounting templates. . . . . | C1SZ-18813-B   | 58.95 |
| 64-66 | Assembly, round base, front fender mount. . . . .                                              | C4SZ-18813-B   | 58.95 |
| 61-66 | Mast, screw-in type . . . . .                                                                  | C1SZ-18A886-A  | 26.95 |
| 61-66 | Mast, screw-in type, concurs correct 4 sided base nut like original . . . . .                  | C1SZ-18A886-AR | 28.95 |
| 58-59 | <b>NEW</b> Grommet, for antenna lead-in wire . . . . .                                         | B5A-18912-A    | 3.95  |
| 58-60 | <b>NEW</b> Base pad, for front fender mounted antenna . . . . .                                | B8A-18818-S    | 6.95  |
| 58-66 | <b>NEW</b> Base pad, for trunk mounted antenna . . . . .                                       | B7A-18818-T    | 6.95  |
| 61-63 | Base pad, for front fender mounted antenna . . . . .                                           | C1SZ-18919-A   | 4.95  |
| 64-66 | Base pad, for front fender mounted antenna . . . . .                                           | C4SZ-18919-A   | 4.95  |

## Original Radio Knobs (2 required)

- |      |                                               |           |      |
|------|-----------------------------------------------|-----------|------|
| 1958 | Radio knob, black with silver insert. . . . . | B8S-18805 | 6.95 |
|------|-----------------------------------------------|-----------|------|



- |       |                                                      |            |      |
|-------|------------------------------------------------------|------------|------|
| 1959  | Radio knob, white with gold insert (shown) . . . . . | B9S-18805  | 6.95 |
| 1960  | Radio knob, white with silver insert. . . . .        | COSF-18805 | 6.95 |
| 58-60 | Radio tone control bezel, chrome . . . . .           | B8S-18830  | 7.95 |

## Antenna Lead Wire Grommet

- |       |                                                                                     |             |      |
|-------|-------------------------------------------------------------------------------------|-------------|------|
| 58-60 | Grommet for antenna lead-in wire, used where antenna wire passes thru body. . . . . | B8S-18912-A | 2.95 |
|-------|-------------------------------------------------------------------------------------|-------------|------|

## Dynamat® Sound Insulation

For years, we have been selling the original Dynamat & can boast hundreds of satisfied customers. We are now proud to offer the next generation of Dynamat sound deadeners: Xtreme. Xtreme is a step up from the original formula & is Dynamat's best product at controlling vibration. It damps 4 times as much as the original Dynamat &, as an added bonus, it weighs 50% less. It is available in conveniently sized 18" x 32" sheets & with peel & stick application; it goes on quickly & easily. Do yourself a favor & order some today!

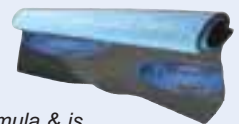

- |     |                                                                             |              |       |
|-----|-----------------------------------------------------------------------------|--------------|-------|
| ALL | <b>NEW</b> Dynamat® Xtreme, each piece is 18" x 32" (as required) . . . . . | DYNAMAT-0433 | 29.95 |
|-----|-----------------------------------------------------------------------------|--------------|-------|

## Undercoating

To fill in the gaps between sound deadener sheets or firewall insulation, use this under coat. Its rubberized formula will protect, seal & insulate.



- |     |                                    |       |        |
|-----|------------------------------------|-------|--------|
| ALL | Under Coat, 17 oz. spray . . . . . | RSP49 | 9.95 * |
|-----|------------------------------------|-------|--------|

\* **HAZARDOUS MATERIAL** can only be shipped by ground/ surface within the U.S. because of government regulations.

# WHEELS

## Wheel Cover & Emblem (4 required)



- |       |                                                |            |       |
|-------|------------------------------------------------|------------|-------|
| 59-60 | Wheel cover, 36 struts, 14" diameter . . . . . | B9A-1130-A | 83.95 |
|-------|------------------------------------------------|------------|-------|



- |       |                                                                              |             |       |
|-------|------------------------------------------------------------------------------|-------------|-------|
| 59-60 | Sun Ray emblem, with die-cast chrome retainer. . . . .                       | B9A-1141-A  | 50.95 |
| 1966  | Center emblem for Deluxe wheel cover, red plastic, 2-1/4" diameter . . . . . | C6SZ-1141-A | 33.95 |

## Spinner Emblem (4 required)



- |      |                                                                                            |             |       |
|------|--------------------------------------------------------------------------------------------|-------------|-------|
| 1965 | Emblem for spinner, black background, chrome bird with red, white & blue accents . . . . . | C5SZ-1141-A | 44.95 |
|------|--------------------------------------------------------------------------------------------|-------------|-------|

## Wheel Stud & Lug Nuts (20 required)



- |       |                                                                              |             |      |
|-------|------------------------------------------------------------------------------|-------------|------|
| 58-66 | Wheel stud, front & rear wheels with drum brakes, 1/2"-20 x 1-5/8" . . . . . | A9AZ-1107-B | 1.95 |
| 58-66 | Lug nut, 1/2"-20. . . . .                                                    | B-1012      | 0.50 |



**Heat, friction, dirt & time** are all enemies of your classic car's vital wheel bearings & grease seals. Wheel bearings are a particular problem area in many collector cars, which are often driven less than typical daily transportation vehicles. It is not uncommon for collector cars to sit unmoved for months or even years.

This inactivity allows the rubber grease seals to harden & set. Then, when the car starts being driven again, the seals can fail allowing grit & moisture inside the wheel bearing surfaces. Furthermore, old wheel bearing grease can harden & dry out, thus losing its lubrication qualities. When that happens, you find yourself driving down the road when a wheel bearing starts to groan & grind against the excessive

friction. Inevitably, this happens at the worst possible times. Inspect your wheel bearings carefully. If they exhibit any signs of rust, wear or slight pitting of the rollers, replace them immediately. (Remember to always replace both the inner & outer bearings of one wheel at the same time).

However, if your inspection finds perfectly good wheel bearings, then wipe out all the old grease & replace it with today's super low-friction wheel bearing grease. Work it carefully into both inner & outer wheel bearings, install new grease seals & you're on your way, confident that all is well with your wheel bearings!

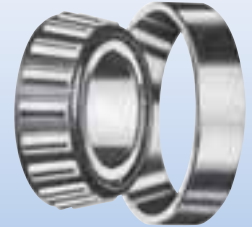

**Front Hub Grease Caps** (2 required) \_\_\_\_\_



- 58-62 1-25/32" ID ..... B5A-1131-A 5.95
- 63-66 **Genuine Ford**, 1-31/32" ..... LF-1131-A 3.95

**Front Hub Grease Cap Tool** \_\_\_\_\_



- 58-62 **NEW** Perfect tool for installing your grease caps. .... TOOL-1131 11.95

**Front Wheel Grease Seals** (2 required) \_\_\_\_\_



- 58-62 1-15/16" ID x 2-1/2" OD ..... B5AZ-1190-A 4.95
- 63-66 1-15/16" ID x 2-3/4" OD ..... C6AZ-1190-A 7.95

**Front Spindle Washer** (2 required) \_\_\_\_\_



- 58-66 Front spindle washer. .... C2AZ-1195-A 8.95

**Inner Front Wheel Bearing Sets** (2 sets required) \_\_\_\_\_

1 set does 1 wheel.



- 58-64 1 bearing & 1 race. .... B5A-1201-ST 15.95 set
- 65-66 1 bearing & 1 race. .... B7C-1201-ST 15.95 set

**Outer Front Wheel Bearing Sets** (2 sets required) \_\_\_\_\_

1 set does 1 wheel.



- 58-62 1 bearing & 1 race. .... B5A-1216-ST 15.95 set
- 63-66 1 bearing & 1 race. .... C3SZ-1216-ST 9.95 set



**Don't forget to pack your wheel bearings in grease!**

**Front Brake Backing Plate Gasket** (2 required) \_\_\_\_\_



- 61-64 Die-cut gasket paper. .... B4A-1193-A 1.95

**Rear Wheel Bearing & Gaskets** (2 required) \_\_\_\_\_



- 58-66 Bearing, stamped 88128, 1-17/32" ID x 3-5/32" OD ..... C1SZ-1225-B 29.95  
Some '61s used a smaller bearing. Be sure to get stamping # or have measurement ready when you call.
- 1961 Bearing, stamped RW207CE or F207AKKK29, 1-3/8" ID x 2-53/64" OD ..... B7AZ-1225-A 29.95
- 58-60 Gasket. .... C5AZ-1001-A 1.95



- 1961 Gasket for rear wheel bearing retainer . A8AZ-1001-A 1.95
- 62-66 Gasket. .... C5AZ-1001-A 1.95

**Grease**

Premium Timken brand wheel grease in a 1 lb. tub with special additives to prevent rust & reduce wear. A must have for installing new bearings, cups & grease caps!



- ALL 1 lb. container ..... GREASE 5.50

**Bearing Grease Packer Kit**

Applies fresh grease evenly to virtually any bearing. The old grease is forced out onto the cone for easy clean up.



- ALL **NEW** Universal, 4-1/2" diameter cone. . . X6150 9.50 kit

**Seal Puller**

Use on any oil or grease seal. Place the tip behind the seal, press & pull.



- ALL **NEW** Universal, two tip sizes fit almost all applications. .... X1175 9.50



## Brake Pedal Mounting Bracket Bushing & Insulator



- 60-61 Brake & clutch mounting bracket bushing, plastic, before 3-21-61 (4 required) . . . . . B7AZ-2471-B 1.95
- 58-60 Brake pedal bushing to spring insulator . . . . . B5A-2481-A 22.95

## Brake Pedal Arm Bumper



- 58-64 **NEW** Rubber, replacement type . . . MA-7583-A 2.95

## Brake, Clutch & Emergency Brake Pedal Pads

Ask an old used car salesman & they will tell you that one of their favorite tricks for determining the condition of any used car is to look at the foot pedal pads. Worn brake pedal or gas pedal pads are quick tip-offs to worn-out cars. By contrast, brand new pedal pads tend to add to the "new car" look of any interior. Take a look at our low, low prices & be assured that our quality is high. Dress up your interior one more way—call & order new pedal pads today. Go for it!

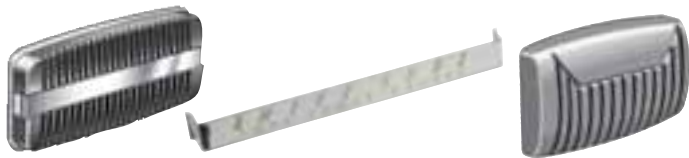

- 1958 Brake pedal pad, does not include the "Swift Sure" band . . . . . B5S-2454-P 28.95
- 1958 **NEW** Stainless steel band, with "SWIFT SURE FORD POWER BRAKES" stamped into it, fits pedal B5S-2454-P above. . . . . B5S-2454-SS 19.95
- 58-60 Brake pedal pad, manual transmission, brake or clutch pedal (2 required) . . B7A-2457-A 4.95



- 58-61 Brake pedal & pad, automatic transmission, manual brakes (shown) . . . . . AB-2454-B 14.95
- 58-62 Brake pedal & pad, automatic transmission, power brakes, serviceable but not "correct" for 1958 (shown) . . . . . B9A-2454-B 28.95
- 58-62 Brake pedal pad, automatic transmission, power brakes, serviceable but not "correct" for 1958-60 . . . . . C1SS-2457-C 9.95
- 63-64 Brake pedal pad, with stainless steel trim, power brakes. . . . . C3SZ-2454-A 55.95
- 65-66 Brake pedal pad, with stainless steel trim, power brakes. . . . . C5SZ-2454-A 55.95



- 61-64 Emergency brake pedal pad . . . . . B9A-2454-A 5.95
- 65-66 Emergency brake pedal pad . . . . . C8SZ-2454-AR 5.95

## Brake Drums (2 required)

### Front



- 58-60 For 11-1/32" x 2-1/2" brake shoes, hub not included . . . . . C3AZ-1126-A 74.95
- 61-62 For 11-1/32" x 3" brake shoes, hub not included . . . . . C5AZ-1125-A 121.95
- 63-64 For 11-3/32" x 3" brake shoes, hub not included . . . . . C3SZ-1102-C 111.95

### Rear

- 1958 For 11-1/32" x 2" brake shoes. . . . . B7S-1126-A 107.95
- 59-62 For 11-1/32" x 2-1/2" brake shoes . . C3AZ-1126-A 74.95
- 63-66 For 11-3/32" x 2-1/2" brake shoes . . C3SZ-1126-A 105.95

## Brake Shoes

All of our relined brake shoes are sold on an exchange basis. If we do not have your rebuildable cores before we ship a core fee of \$30.00 will be charged. This core fee will be refunded if an acceptable exchange is received within 90 days of purchase date.

Always measure your drum diameter & brake shoe width before ordering, to be sure you get the correct set of shoes.

### Front



- 58-60 11-1/32" x 2-1/2" brake shoes. . . . . C3AZ-2001-ST 34.95 set
- 61-62 11-1/32" x 3" brake shoes . . . . . C2SZ-2001-ST 35.95 set
- 63-64 11-1/32" x 3" brake shoes . . . . . C3SZ-2001-ST 35.95 set

### Rear

- 1958 11-1/32" x 2" brake shoes . . . . . B8S-2200-ST 34.95 set
- 59-62 11-1/32" x 2-1/2" brake shoes. . . . C3AZ-2001-ST 34.95 set
- 63-66 11-3/32" x 2-1/2" brake shoes. . . . C3AZ-2200-ST 29.95 set

## Brake Shoe Return Springs



- 58-60 Front (4 required) . . . . . B5A-2035-A 2.95
- 1961 Requires B5A-2035-A below (2 required) . . . . . C1SS-2035 2.95
- 1961 Requires C1SS-2035 above (2 required) . . . . . B5A-2035-A 2.95
- 62-64 Front (4 required) . . . . . B5A-2035-A 2.95
- 58-66 Rear (4 required) . . . . . B5A-2035-A 2.95





Your brake hardware is at least 40 years old—now is the time to replace any or all of it. We carry return springs, adjusting springs, hold down kits, self adjuster cables, self adjuster repair kits, even the backing plate bolts, so put safety first & give us a call right away!

**Brake Shoe Adjusting Springs**



- 58-60 Front or rear (2 or 4 required) . . . . . H-2049 2.95
- 61-62 Front (2 required) . . . . . C1SS-2049 2.95
- 1962 Rear (2 required) . . . . . C1SS-2049 2.95
- 1963 Front or rear (2 or 4 required) (not shown) . . . . . C3SZ-2049-A 3.95
- 65-66 Rear (2 required) (not shown) . . . . . C3SZ-2049-A 3.95

**Brake Shoe Hold Down Kits**

The springs, clips & other parts that operate your brake shoes are subject to tremendous heat, corrosion & other elements, which tend to weaken them severely. Replace all springs, adjusters & other hardware while you're doing your brake job to ensure proper performance. These easy to use kits include hold down springs, nails, washers & the rubber dust covers.

Kit components are not sold separately.



- 1958 22 pieces, rear (shown) . . . . . A9A-2068-KT 9.95 kit
- 58-60 18 pieces, front . . . . . B5A-2068-KT 9.95 kit
- 61-64 20 pieces, front, requires 2 kits per axle (2 kits required) . . . . . C1AZ-2068-KT 9.95 kit
- 61-66 18 pieces, rear, requires 2 kits per axle (2 kits required) . . . . . B5A-2068-KT 9.95 kit

**Rear Brake Emergency Brake**

**Link Spring** (2 required)



- 58-62 . . . . . A8TZ-2A601-A 5.95

**Brake Shoe Adjuster Repair Kits** (1 or 2 required)

Kits contain a star wheel assembly, lever, brake adjusting hole plug, self-adjuster cable & the cable guide. You will need 1 kit per wheel.



- 61-66 5 pieces, right, front or rear. . . . . COLL-2A176-KT 11.95 kit
- 61-66 5 pieces, left, front or rear. . . . . COLL-2A177-KT 11.95 kit

**Brake Shoe Star Wheel**

**Adjuster Assemblies** (2 required)



- 58-60 Front, right or left. . . . . B5A-2041-A 9.95
- 58-60 Rear, right or left . . . . . B5A-2041-A 9.95
- 61-62 Front or rear, right . . . . . B8A-2041-A 12.95
- 61-62 Front or rear, left . . . . . C1AZ-2041-A 12.95
- 65-66 Front or rear, right . . . . . B8A-2041-A 12.95
- 65-66 Front or rear, left . . . . . C1AZ-2041-A 12.95

**Brake Self Adjuster Cables**



- 61-62 Front or rear brakes (4 required) . . . . . C1SS-2A178 4.95
- 65-66 Rear brakes (2 required) . . . . . C1SS-2A178 4.95

**Brake Adjustment Hole Plug** (2 or 4 required)



- 58-66 Rubber, drum brakes . . . . . 8A-2092 0.95

**Brake Shoe "C" Clip (Horseshoe Lock) & Washer** (2 required)



- 58-66 Brake shoe "C" clip (horseshoe lock), secures parking brake lever to brake shoe . . . . . 91A-2106 0.75
- 58-66 Brake shoe "C" clip anti-rattle washer, spring steel, **Genuine Ford** . . . . . 351467-S 1.95

**Backing Plate Bolt** (8 required)



- 58-66 1/2"-20 x 1-29/64", **Genuine Ford** . . . . . C2AZ-2248-A 4.95

**Brake Shoe to Wheel**

**Cylinder Link** (8 required)



- 58-66 . . . . . B7A-2042-A 4.95



If your master cylinder is the heart of the brake system, then the wheel cylinders are surely the muscles. They directly convert hydraulic pressure into the mechanical motion that presses the brake shoes against the rotating brake drum surface, stopping the vehicle with a huge amount of friction. If a wheel cylinder freezes up or begins to leak, the entire system ceases to function properly. We have all experienced the frustration of bleeder valves that are stuck, or worse, that break. Be sure your brake system is in tip-top shape with brand new wheel cylinders!

## Front Brake Wheel Cylinders

Always change wheel cylinders in pairs.



1958	Right, 1-1/8" bore (shown)	B7A-2061-A	32.95
1958	Left, 1-1/8" bore	B7A-2062-A	32.95
59-60	Right, 1-3/32" bore	B9SS-2061-A	41.95
59-60	Left, 1-3/32" bore	B9SS-2062-A	32.95
61-64	Right, 1-3/32" bore	C2VY-2061-A	27.95
61-64	Left, 1-3/32" bore	C2VY-2062-A	27.95

## Wheel Cylinder Bleeder Screw (2 or 4 required)



58-66		8M-2208	1.95
-------	--	---------	------

## Rear Brake Wheel Cylinders

Always change wheel cylinders in pairs.



1958	Right, 7/8" diameter (shown)	C3AZ-2261-B	24.95
1958	Left, 7/8" diameter	C3AZ-2262-B	24.95



59-60	Right, 29/32" diameter (shown)	B9S-2261-A	24.95
59-60	Left, 29/32" diameter	B9S-2262-A	24.95



61-62	Right, 7/8" diameter (shown)	C3AZ-2261-B	24.95
61-62	Left, 7/8" diameter	C3AZ-2262-B	24.95



63-66	Right, 15/16" diameter (shown)	B7A-2261-A	24.95
63-66	Left, 15/16" diameter	B7A-2262-A	24.95

## Wheel Cylinder Rebuild Kits (2 required)

Many wheel cylinders can be honed & rebuilt with our inexpensive kits. Inspect your cylinders for excessive wear & if you decide to rebuild, give us a call. We'll be happy to send your kits out today!

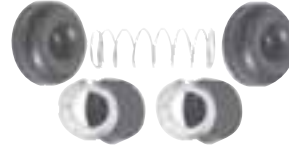

### Front

1958	For 1-1/8" diameter wheel cylinders	8M-2221	12.95 kit
59-64	For 1-3/32" diameter wheel cylinders	C3AZ-2221-A	15.95 kit

### Rear

1958	For 7/8" diameter wheel cylinders	8A-2128	5.95 kit
59-60	For 29/32" diameter wheel cylinders	C3OZ-2128-B	12.95 kit
61-62	For 7/8" diameter wheel cylinders	8A-2128	5.95 kit
63-66	For 15/16" diameter wheel cylinders	B2A-2128	12.95 kit



It is always a good idea to replace brake hoses if you're uncertain of their condition. Hard-to-see stress cracks or inner deterioration can lead to leaks & brake failure. Check out our extensive supply of hoses for front or rear brakes, make your selection & give us a call right away!

## Brake Hoses



### Front (2 required)

1958	14", wheel cylinder to connector (outer)	B8SZ-2078-A	28.95
1958	15", inner	B7AZ-2078-AR	19.95
59-60	9-1/2", wheel cylinder to connector (outer)	B9SZ-2078-AR	29.95
59-60	14-1/8", inner	B4AZ-2078-A	19.95
61-64	15"	B7AZ-2078-AR	19.95

65-66	13-3/4"	C5SZ-2078-B	16.95
-------	---------	-------------	-------

### Rear

58-60	15"	B7AZ-2078-AR	19.95
-------	-----	--------------	-------



61-62	18"	C2SZ-2282-AR	19.95
62-63	18-5/8", with "tee" end & bracket	C3SZ-2282-AR	42.95
64-66	14-1/4", with "tee" end & bracket	C4SZ-2282-AR	44.95

## Brake Hose Hardware



59-60	Clip (3 required)	78-2814	0.95
63-64	Clip (3 required)	78-2814	0.95
65-66	Banjo bolt, for front hose (2 required)	380086-S	10.95



**Rear Brake Line Fitting**



58-60 Brass . . . . . 8A-2074 9.95

**Brake Line Copper Washer (as required)**

58-66 . . . . . 8M-2149 1.95

**Brake Proportioning Valve Rebuild Kit**



65-66 . . . . . C5SZ-2B091-KT 16.95 kit

**New Master Cylinders**

*If you want to save yourself hours of time cleaning, honing & rebuilding your old master cylinder, give us a call & order one of our brand new master cylinders. Guaranteed to be expertly assembled from only premium quality parts, it will provide you with years of trouble-free service.*



58-60 1" bore, attaches with 4 bolts . . . . . B5A-2140-B 69.95  
1961 1" bore, before 6-9-61 . . . . . COAZ-2140-B 69.95



61-64 7/8" bore, from 6-9-61 . . . . . C1SZ-2140-A 79.95  
65-66 15/16" bore . . . . . C5SZ-2140-A 110.95

**Master Cylinder Rebuild Kits**



*Check out these convenient & affordable master cylinder rebuild kits. If your unit is still in great shape, with no pitting or rust inside, they're a cost-efficient alternative to new cylinders.*

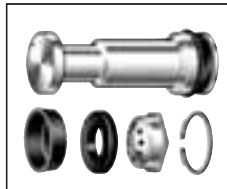

58-61 **NEW** 1" bore, before 6-9-61 (shown) . . . . . B5A-2004-KT 16.95 kit  
61-64 7/8" bore (shown) . . . . . C1SZ-2004-AKT 14.95 kit  
65-66 15/16" bore, before 1-3-66 . . . . . C5SZ-2004-KT 19.95 kit  
1966 7/8" bore, from 1-3-66 to 4-1-66 . . . . . C1SZ-2004-AKT 14.95 kit

**Master Cylinder Filler Caps & Gaskets**



58-60 Cap, made by Wagner . . . . . AB-2162-CR 9.95  
61-64 Cap, gold anodized like original, gasket included, reproduction . . . C5ZZ-2162-G 18.95  
61-64 Cap, chrome, gasket included, reproduction . . . . . C5ZZ-2162-BC 18.95



65-66 Cap, gold anodized, gasket not included . . . . . C5SZ-2162-AG 27.95  
65-66 Cap, chrome, gasket not included . C5SZ-2162-AC 25.95



58-60 Gasket . . . . . 8M-2167 1.95  
61-64 Gasket set (not shown) . . . . . COAA-2167-B 12.95 set  
65-66 Gasket, 4-7/64" OD, with disc brakes. . . . . C5SZ-2167-A 7.95

**Master Cylinder Boot**



58-60 . . . . . 0A-2180 3.95

**Master Cylinder Outlet Fitting Bolt**



58-59 . . . . . 91T-2276 9.95

**Master Cylinder Link Rod Bolt**



58-62 Has an offset thread, **Genuine Ford** . . . . . COTT-2462-A 17.95

**Master Cylinder Push Rod Bushings & "O" Ring**



58-64 Master cylinder push rod bushing, (2 required) . . . . . B2A-2474-A 5.95  
58-66 Master cylinder square cut "O" ring (not shown) . . . . . B8S-2493-A 2.95  
65-66 Master cylinder push rod bushing, 5/16" long . . . . . C5DZ-2474-AR 1.95





## Disc Brake Rotor (2 required)

Stop searching for used rotors! Our rotors are newly manufactured to original specs.



65-66 Does not include hub . . . . . C5SZ-1102-A 148.95

## Disc Brake Pad & Retainer



65-66 Disc brake pad set . . . . . C5SZ-2001-ST 28.95 set

65-66 Disc pad retainer or shield (2 required) . . . . . C5SZ-2B127-A 14.95

## Rebuilt Disc Brake Calipers

MAC's rebuilt calipers are sold on an exchange basis. Your rebuildable core must be returned in the rebuilder's original package. The core fee of \$75.00 will be refunded if an acceptable core is received within 90 days of your purchase date. Units with cracked or broken housings are not considered acceptable core exchanges.



65-66 4 pistons, right (shown) . . . . . C5SZ-2B120-AR 149.95  
65-66 4 pistons, left . . . . . C5SZ-2B121-AR 149.95

## Caliper Transfer Tubes

65-66 Stainless steel . . . . . C5SZ-2K006-PR 30.95 pair  
65-66 Right, plain steel . . . . . C5SZ-2K006-B 15.95  
65-66 Left, plain steel . . . . . C7AZ-2B126-A 15.95

## Brake Line Kits, O.E.M. Steel & Stainless Steel

Original equipment steel lines are steel tubing, double-wrapped for strength, copper plated & specially coated to resist corrosion. The brake line kits below are made from seamless 304-grade double-annealed stainless steel tubing & have a 6000 PSI bursting strength. They come to you pre-bent to original specifications. All fittings are also stainless steel. Please allow 5 to 6 weeks for delivery.

**2 WEEKS** **OS** All brake line kits are oversize & require additional shipping.

1958 Manual brakes, stainless steel . . . B8S-2269-MSS 159.95 kit  
1958 Power brakes, booster under dash, stainless steel . . . . . B8S-2269-MSS 159.95 kit  
59-60 Manual brakes, original equipment steel . . . . . B9S-2269-AKT 134.95 kit  
59-60 Manual brakes, stainless steel . . . B9S-2269-MSS 159.95 kit  
59-60 Power brake, booster on firewall, original equipment steel . . . . . B9S-2269-BKT 169.95 kit  
59-60 Power brake, booster on firewall, stainless steel . . . . . B9S-2269-PSS 169.95 kit  
61-62 Power brake, original equipment steel . . . . . C1SZ-2269-KT 134.95 kit  
61-62 Power brake, stainless steel . . . . C1SZ-2269-PSS 159.95 kit

1963 Power brake, original equipment steel . . . . . C3SZ-2269-KT 134.95 kit  
1963 Power brake, stainless steel . . . . C3SZ-2269-PSS 159.95 kit  
1964 Power brake, original equipment steel . . . . . C4SZ-2269-KT 134.95 kit  
1964 Power brake, stainless steel . . . . C4SZ-2269-PSS 169.95 kit  
65-66 Power brake, original equipment steel . . . . . C5SZ-2269-KT 134.95 kit  
65-66 Power brake, stainless steel . . . . C5SZ-2269-PSS 159.95 kit

## Remanufactured Power Brake Boosters & Master Cylinder Assemblies

Common problems in classic T-Birds are defective boosters & master cylinders. Bring your Birds stopping power back to the level it was when it was built by installing one of our assemblies, call us today & we will be more than happy to send one your way! MAC's remanufactured power brake boosters & master cylinder assemblies are sold on an exchange basis. Your rebuildable core must be returned in the rebuilder's original package. The core fee will be refunded if an acceptable core is received within 90 days of your purchase date. The Kelsey-Hayes bellows type under dash booster used from 1958-60 is no longer available.

59-60 Remanufactured power brake booster with master cylinder, dealer installed, **Rebuild only** . . . . . PB95445 199.95  
1961 Remanufactured power brake booster with master cylinder, screw type, screws hold 2 halves of the booster chamber together, screws point toward radiator, **Rebuild only** . . . . . PB00900 199.95

Originally, T-Birds from 1961-1963 used the screw type power brake booster, while 1964 used the band type. These two types however, are interchangeable.

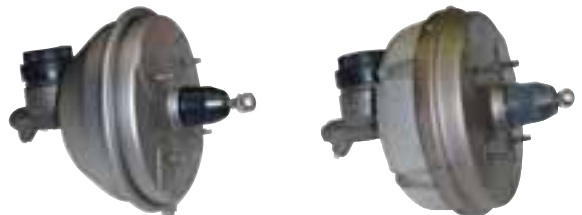

61-64 Remanufactured power brake booster with master cylinder, clamp band type, **\$200.00 core fee** . . . . . PB10751B 199.95  
61-64 Remanufactured Bendix power brake booster with master cylinder, screw type, screws hold 2 halves of booster chamber together, screws point into vacuum chamber, **\$200.00 core fee** . . . . . PB10751S 199.95



1965 Remanufactured power brake booster with master cylinder, push rod 2-7/8" to center of eye, twist lock type, **\$75.00 core fee, Rebuild only** . . . . . PB04054 199.95  
65-66 Remanufactured Midland power brake booster with master cylinder, clamp band type, **Rebuild only** . . . . . PB27651 199.95



**Power Brake Booster Rebuild Kit** \_\_\_\_\_



58-60 For under-dash Kelsey-Hayes bellows-type booster . . . . . B8S-2005-KT 79.95 kit

**Power Brake Booster Check Valve** \_\_\_\_\_

61-66 Includes gasket, not for boosters with screw-in type check valve . . . . . C4AZ-2365-AR 23.95

**Power Brake Booster Vacuum Lines** \_\_\_\_\_

*From brake booster to manifold.*

58-60 Plain steel . . . . . B8S-2369 13.95  
58-60 Stainless steel . . . . . B8S-2369-SS 18.95  
1966 Plain steel . . . . . C6SZ-2369 7.95  
1966 Stainless steel . . . . . C6SZ-2369-SS 11.95



*Ford emergency brake systems are relatively simple & generally reliable. But when corrosion, wear, non-usage & time take their toll, the emergency (or parking) brake system can let you down. Carefully examine the components on your classic T-Bird, if they seem corroded, worn, or just plain reluctant to move freely, replace them immediately. MAC's has the parts you need. Call now!*

**Front Emergency Brake Cables** \_\_\_\_\_

58-60 42" long . . . . . B8S-2853-A 39.95  
61-66 64" long . . . . . C1SZ-2853-A 36.95

**Rear Emergency Brake Cables** \_\_\_\_\_

1958 159-7/16" long . . . . . B8S-2A635-A 36.95  
1959 **Except** 430 engine, 80" long (2 required) . . . . . B9S-2A635-A 36.95  
1960 77" long (2 required) . . . . . COSS-2A635-A 36.95



61-62 96-1/2" long (2 required) . . . . . C1SS-2A635-A 39.95  
1963 82-1/4" long (2 required) . . . . . C3SZ-2A635-A 42.95  
64-66 82-1/2" long (2 required) . . . . . C4SZ-2A635-A 39.95

**Emergency Brake Cable Clips** \_\_\_\_\_



58-59 Cable to dash . . . . . 8M-2814 2.95  
58-59 Cable to frame (2 required) . . . . . 8M-2814 2.95  
1960 Cable to frame, front bracket & dash (4 required) . . . . . 8M-2814 2.95

**Emergency Brake Cable Pulley** \_\_\_\_\_



58-60 Emergency brake cable pulley . . . . . 0M-2804 23.95

**Brake Shoe "C" Clip (Horseshoe Lock) & Washer (2 required)** \_\_\_\_\_



58-66 Brake shoe "C" clip (horseshoe lock), secures parking brake lever to brake shoe . . . 91A-2106 0.75  
58-66 Brake shoe "C" clip anti-rattle washer, spring steel, **Genuine Ford** . . . . . 351467-S 1.95

**Emergency Brake Pedal Pads** \_\_\_\_\_



61-64 Rubber . . . . . B9A-2454-A 5.95  
65-66 Rubber . . . . . C8SZ-2454-AR 5.95

**Emergency Brake Equalizer Rod** \_\_\_\_\_



59-66 Universal, cut to length . . . . . B7A-2628-B 13.95

**Emergency Brake Release Vacuum Canister** \_\_\_\_\_

64-66 . . . . . C4SZ-2780 55.95

**Emergency Brake Ratchet Parts** \_\_\_\_\_



58-60 Emergency brake ratchet spring . . . . . 0M-2788 2.95  
58-60 Knurled pin, for emergency brake ratchet. 0M-2859 3.95  
1960 Emergency brake ratchet pawl (not shown) . . . . . 0M-2786 7.95

**Emergency Brake Adjusting Nut** \_\_\_\_\_



58-66 **NEW** Emergency brake adjusting nut . . . . . 8A-2091 5.95



Get your vintage T-Bird driving & handling like it did when it was new, with all new steering & suspension parts. Those old & worn bushings, ball joints, tie rod ends, idler arms & springs have no doubt seen their share of bad weather, bad roads & poor driving conditions.

Do yourself a favor, check your front end components, or have a professional mechanic do it. If you need new inner or outer tie rods give us a call. While you're at it, don't forget the connecting sleeves, we have those too. In fact, **give us a call for all of your needs** ... we are here to help keep you & your car safe, any way that we can. You'll be glad you did!

## Inner Tie Rods

1958	Right (shown) . . . . . B7A-3280-A	44.95
1958	Left . . . . . B7A-3281-A	44.95
59-60	Right (shown) . . . . . B9AA-3280-A	116.95
59-60	Left . . . . . B9AA-3281-A	120.95
61-64	Right or left (2 required) . . . . . C3SZ-3280-A	55.95
65-66	Right or left (2 required) . . . . . C5SZ-3A131-A	65.95

## Outer Tie Rods (2 required)

58-60	Outer tie rod . . . . . 11A-3271	13.75
61-66	Outer tie rod . . . . . C5SZ-3A130-A	48.95

## Center Link/Drag Links

61-62	Center link/drag link . . . . . C1SZ-3304-A	100.95
63-64	Center link/drag link . . . . . C3SZ-3304-C	99.95

## Tie Rod Connecting Sleeve (2 required)

58-66	Right or left . . . . . 11A-3310	9.95

## Grease

Premium Timken brand wheel grease in a 1 lb. tub with special additives to prevent rust & reduce wear. A must have for installing new bearings & cups!



**Don't forget to fully grease tie rods after installing them.**

ALL	<b>NEW</b> 1 lb. container . . . . . GREASE	5.50
-----	---------------------------------------------	------

## Tie Rod Rubber End Cup

58-60	4-piece set. . . . . 48-3332-ST	5.95 set

## Idler Arms

58-59	Idler arm bracket, manual steering . . . . . 8A-3351	11.95
58-60	Manual steering . . . . . AN-3355-B	134.95
58-60	Power steering . . . . . B4A-3352-B	31.95

61-63	Power steering . . . . . C1SZ-3A734-A	238.95

From 1961 to 1963, Thunderbirds had a small diameter shaft on the frame bracket. It proved to be a weak link, so when a reproduction was being planned it was decided to use the larger diameter shaft for the 1964 model. That shaft, along with the larger bushing, makes this reproduction much stronger than the original.

1964	Power steering (2 required) . . . . . C3SZ-3A734-BR	140.95
65-66	Power steering . . . . . C5SZ-3A734-A	218.95

## Pitman Arm

65-66	Pitman arm with hardware . . . . . C5SZ-3590-A	172.95

## Idler Arm Seal & Bushings

58-60	Seal, manual steering (2 required) . . . . . 8M-3359	1.95
58-59	Bushing, manual steering (2 required) .MB-3356-A	4.95
58-60	Bushing, power steering, upper . . . . . MA-3356-B	11.95
58-60	Bushing, power steering, lower . . . . . MA-3358-A	8.95





- 1961 Bushing, before 4/14/61 . . . . . CODD-3356-A 13.95
- 61-62 Bushing, from 4/14/61 thru 3/16/62. .C3AZ-3356-A 8.95
- 62-63 **NEW** Idler arm bushing, from  
3/15/62 . . . . . C3SZ-3356-A 31.95
- 64-66 1-7/16" OD x 7/8" ID (not shown) . . C3DZ-3356-C 28.95

**Rebuilt Steering Gearboxes**

*It's important that we receive your old rebuildable core before shipping out your rebuilt gearbox. If we do not receive your core before shipping, you will be charged a \$200.00 core fee. Upon receiving your core, we will gladly refund this charge.*



*When sending in your core, please drain it as much as possible & double-wrap it; that is, put it in a bag & seal it with tape, then take that bag & put it in another bag & seal that with tape. Trash bags work very well for this.*

- 61-62 61 thru early 62, with pin type steering shaft coupler, casting #C1SR 3550 D . . . . . C1SZ-3504-A 511.95
- 1962 Mid 62 thru year end, with bolt on type steering shaft coupler, casting #C2SR 3550 B . . . . . C2SZ-3504-A 511.95
- 63-64 Casting #C2VR 3550 A or #C3VR 3550 A. . . . . C4VY-3504-A 511.95
- 65-66 Casting #C5VR 3550 A, #C6VR 3550 A, #C6VR 3550 B, # C6VR 3550 C or #C8VR 3550 A . . . . . C8VY-3504-A 511.95

**Steering Gearbox Insulator (Mount) (3 required)**



- 63-66 This is the steel encased rubber mount from the gearbox to the frame, always check these when you are changing the gearbox, vague steering can be a symptom of bad insulators . . . . . C3SZ-3C716-B 44.95

**Steering Gearbox Seal Kits**



- 61-64 Complete. . . . . C1VY-3C538-A 63.95 kit
- 65-66 For bottom end of gearbox . . . . . D7AZ-3E501-KT 15.95 kit
- 65-66 Complete. . . . . C5AZ-3C538-AKT 37.95 kit

**Steering Gearbox Worm Roller Bearing & Race (2 required)**



- 58-66 . . . . . C2AZ-3571-A 41.95

**Steering Gearbox Sector Shaft Bushing & Bearing (2 required)**



- 58-60 1-1/8" ID x 1-3/8" OD x 1" long . . . . . 68-3576 6.95

**Steering Gearbox Sector Shaft Seals**



- 58-60 1-5/64" ID x 1-9/16" OD x 1/4" thick (shown) . . . . . 8A-3591-A 4.95
- 61-64 1-1/4" ID x 1-3/4" OD x 1/4" thick . . . C2SZ-3591-A 6.95

**Steering Gearbox Housing Cover Gasket**



- 58-60 **NEW** Gasket . . . . . B8A-3581-A 1.95

**Upper Steering Column Collar**

- 64-66 Black vinyl covered metal, for woodgrain wheel cars only . . . . C4SZ-3491 22.95

**Lower Steering Column Bushing**

- 58-60 Fits into the lower end of the steering column. . . . . B9S-3674-A 12.95

**Lower Steering Column Seals**



- 58-60 Lower steering column seal (shown) . . . . . B8S-3513-A 4.95
- 61-64 Lower steering column seal . . . . . C1SS-3513-D 33.95

**Steering Column Shaft Bushing**



- 63-66 Nylon tapered cone. . . . . C3SZ-3C773-B 15.95

**Steering Column Upper Bearings**



- 58-60 1.44" OD, **Genuine Ford** . . . . . 21A-3517 3.95
- 61-66 1-3/16" OD, **Genuine Ford**. . . . . C5SZ-3517-A 18.95

**Steering Column Upper Bearing Sleeves**



- 1960 Plastic, **Genuine Ford** . . . . . B1AZ-3518-A 8.95
- 65-66 Rubber, 3/8" ID x 1-1/16" OD x 1/4" thick . . . . . C5SZ-3518-AR 9.95

**Steering Wheel & Parts**

- 58-60 White . . . . . B8S-3600-WHT 299.95



- 58-60 **NEW** Insert spear set, 3 pieces, chrome . . . . . B8SZ-3C680-ST 41.95 set



## Remanufactured Power Steering Pumps

The heat & pressure inside of a power steering system can lead to excessive wear & annoying, hard-to-find leaks. We're proud to offer these guaranteed top quality remanufactured power steering pumps for your engine. They look as good as they perform! Call & order today! If your acceptable exchange has not been received prior to shipping, you will be charged a **\$150.00 core fee**.

If your acceptable core is received within 90 days in the rebuilders' original package the core fee will be refunded.

**NOTE: Rear-Mounted Type not used on 1958-1965 Thunderbirds.**

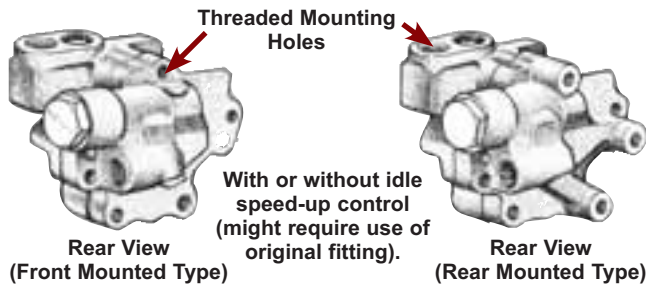

- 58-65 Remanufactured Eaton power steering pump, front mounted (see illustration), **\$150.00 core fee** . . . . . COAZ-3A674-FM 159.95



**DO NOT  
SEND YOUR PULLEY  
WITH YOUR CORE!**

- 65-66 Remanufactured Ford power steering pump, this is a later year replacement style with the small filler neck, **\$75.00 core fee** . . . . . D3AZ-3A674-A 94.95

**Eaton Pump Note:** When returning your Eaton pump core, do not send the reservoir. Your remanufactured pump will not include a reservoir.

## Eaton Power Steering Reservoir Filter & Parts

This filter fits inside the reservoir of your Eaton power steering pump, many pumps that we've seen don't have any filter at all. It's just like any filter & should be changed periodically.

- 58-65 Filter retainer, for Eaton pump, the filter sits in this, for cars without air conditioning . . . . . B8SZ-3C677-A 14.95
- 58-60 Lid seal, for the Eaton pump . . . . . COAA-3A642-B 2.95



- 58-64 **NEW** Reservoir lid bolt, for the Eaton pump . . . . . 354668-B 6.95
- 58-64 **NEW** Reinforcement plate, fits in the bottom of the reservoir, for the Eaton pump . . . . . B5AZ-3B563-A 5.95



- 58-64 **NEW** Seat for filter retaining spring, for the Eaton pump . . . . . B4AZ-3B754-A 2.95
- 61-64 Lid seal, with air conditioning (reservoir is on the fender apron), for the Eaton pump . . . . . COAA-3A642-C 2.95
- 61-65 Lid seal, without air conditioning, for the Eaton pump . . . . . COAA-3A642-B 2.95



- 62-65 Aftermarket replacement, 2-1/2" OD x 1" ID x 1-1/2" high, this is the same size as the original Ford filter but it doesn't have the cork pads on top & bottom that the original has. . . . . B7A-33538-AR 19.95

## Filler Caps



- 60-65 For Eaton pump, does not include dipstick, zinc plated . . . . . C3AZ-3A006-A 13.95
- 60-65 For Eaton pump, does not include dipstick, chrome plated . . . . . C3AZ-3A006-ACH 17.95



- 65-66 Does not include dipstick, zinc plated . . . . . C5AZ-3A006-B 13.95
- 65-66 Does not include dipstick, chrome plated . . . . . C5AZ-3A006-BCH 12.95



- 65-66 For angled, wide neck Ford power steering pump, with dipstick . . . . . C5AZ-3A006-C 12.95
- 65-66 Includes dipstick, chrome plated . . . . . C5AZ-3A006-CCH 14.95

## Gasket

- 58-65 For Eaton pump . . . . . C1AA-3A006-GSKT 1.95



**Power Steering Pump Seal Kits**

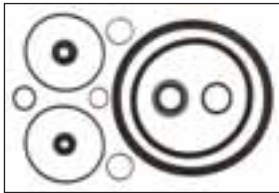

- 58-65 10 pieces, Eaton pump . . . . . C2SZ-3B584-KT 14.95 kit
- 65-66 7 pieces, Ford pump . . . . . D1AZ-3B584-KT 9.95 kit

**Remanufactured Power Cylinders**

*These remanufactured power cylinders are not sold with a core. We rebuild yours.*

*Allow 3 to 4 weeks for rebuilding. Price listed is only an estimate.*

- 1958 . . . . . B7AZ-3A540-A 344.95 +/-
- 1960 . . . . . COSS-3A540-A 296.95 +/-



- 58-60 Bushings, at the inner end, 2 specially tapered rubber bushings that fit in the eye of the cylinder. . . . . B3AZ-3C589-A 3.95 pair



- 58-60 Rebuild kit, for the piston rod end, consists of 2 rubber bushings, 2 washers, 2 nuts & 1 sleeve . . . B7A-3540-KT 18.95 kit



- 58-60 **NEW** Mounting kit, at the piston rod end, consists of 2 rubber bushings, 2 nuts & 1 sleeve . . . . . B7AZ-3C590-KT 14.95 kit

**Power Cylinder Seal Kit**



- 58-60 7 pieces . . . . . C1AZ-3A764-KT 14.95 kit

**Miscellaneous Power Steering Lines**

- 58-59 Power steering control valve to power cylinder line (2 required). . . . . CV-8640 25.95
- 58-60 Power steering pump to control valve return line, includes fitting . . . . . RL-8020 28.95
- 1960 Power steering control valve to power cylinder line set, 2 pieces . . . . . COSS-3A714-B 43.95 set
- 1960 Power steering control valve to power cylinder line set, 2 pieces, stainless steel COSS-3A714-BSS 54.95 set
- 61-62 Return line, steel tube, requires rubber line listed below . . . . . C1SS-3B721-B 16.95
- 61-62 Return line, stainless steel tube, requires rubber line listed below . . . . . C1SS-3B721-SS 21.95
- 61-62 **NEW** Specially reinforced rubber line, with no fittings . . . . . RL-93428 9.95



*Few people realize just how much pressure is inside a typical power steering system. But if you have ever seen a power steering hose burst, you know that it can send hot, oily fluid spraying all over everything & if the hood is open, will spray many feet in all directions.*

*Age, heat & corrosive elements all contribute to the weakening of all power steering hoses & fittings. Look closely at the power steering hoses on your classic Ford. If you see age cracks, worn places, rusted fittings, or stiffened areas, replace them with brand new power steering hoses now...before they fail.*

**Power Steering Pump Pressure Lines**



- 58-60 Power steering pressure line, **except** 430 (shown) . . . . . PL-818 39.95
- 61-63 Power steering pressure line . . . . . PL-040 39.95



- 64-65 Power steering pressure line, Eaton pump (shown) . . . . . PL-862 72.95
- 1965 Power steering pressure line, Ford pump . . PL-902 27.95
- 1966 Power steering pressure line . . . . . PL-902 27.95
- 65-66 Stainless steel tube, Ford pump, attaches pressure line to pump . C5SZ-3494-BSS 23.95
- 65-66 Steel tube, for Ford pump, attaches pressure line to pump . . C5SZ-3494-B 20.95

**Clamp for Return Line**

- 58-66 . . . . . B5A-2344-A 1.95

**Control Valves & Parts**

*The remanufactured control valves listed below are not sold with a core. We must rebuild yours. Allow 3-4 weeks for rebuilding. Price list is an estimate only.*



- 1958 Remanufactured control valve, see note above . . . . . B7AZ-3A730-A 296.95 +/-
- 1959 Remanufactured control valve, see note above . . . . . B9AZ-3A730-C 296.95 +/-
- 1960 Remanufactured control valve, see note above . . . . . COAA-3A730-D 296.95 +/-

*Beginning In 1961 the control valve was built into the steering gear box.*

- 58-60 Control valve end cap . . . . . C2AZ-3C705-A 21.95
- 58-60 Control valve ball stud shield . . . . . B8SZ-3A728 4.95



- 58-60 **NEW** Seal kit, includes seals for both size valves. . . . . 3A650-KT 13.95 kit



# FRONT SUSPENSION



## Control Arm Bumpers (2 required)



58-60 Lower.....	B8A-3019-A	8.95
59-60 Upper.....	COAZ-3020-A	7.95

## Upper Control Arm Shaft Kits (2 kits required)

Complete with nuts, washers & bushings.

58-60 .....	B7A-3047-KT	153.95 kit
61-66 .....	C3SZ-3047-KT	72.95 kit

## Upper Control Arm Bushings (4 required)

58-60 .....	B8S-3068	6.95
61-66 .....	C2SZ-3068	20.95

## Upper Ball Joints

Proper front end geometry is important to the way your car feels as it drives down the road. Worn ball joints can greatly affect that feel. MAC's sells only top quality ball joints at prices you can afford. Replace yours & make that 40 year old car feel like it just drove off the showroom floor!



**BUY the PAIR & SAVE**

58-60 Right or left (2 required) .....	C1AZ-3049-A	28.95
61-62 <b>Save</b> .....	C2SZ-3049-PR	145.95 pair
61-62 Right .....	C2SZ-3049-A	96.95
61-62 Left .....	C2SZ-3049-B	109.95



63-66 Right or left (2 required) .....	C3SZ-3049-A	61.95
----------------------------------------	-------------	-------

## Lower Ball Joints



58-60 <b>NEW</b> O.E.M. style, cast iron housing, right or left (2 required) (shown) .....	C1AZ-3050-BR	98.95
58-60 Replacement type, right or left (2 required) .....	C1AZ-3050-B	77.95
61-66 O.E.M. style cast iron housing, right .....	C3SZ-3050-AR	58.95
61-66 O.E.M. style cast iron housing, left (shown) .....	C3SZ-3050-BR	58.95

## Front End Alignment Shims (as required)

61-66 1/16" thick .....	C1SS-3054-B	4.95
61-66 1/8" thick .....	C1SS-3054-C	4.95
61-66 1/32" thick .....	C1SS-3054-D	3.95

## Control Arm Bushings & Seal



58-60 Bushing, lower, 2 per arm (4 required) (shown) .....	COAA-3069-A	7.95
61-66 Bushing, lower, 1 per arm (2 required) .....	C1SS-3069-C	16.95
61-66 Bushing "O" ring seal, upper, 2 per arm (4 required) .....	374269-S	1.95

## Strut Rod Bushing Kits



1961 4 pieces, redesigned by our supplier, all 4 pieces are now identical, 1 kit does both sides .....	C1SZ-3A187-KT	72.95 kit
62-66 10 pieces, 1 kit does both sides .....	C2SZ-3A187-KT	50.95 kit

# STABILIZER BAR PARTS

## Stabilizer Bar Mounting Bracket



59-60 Stabilizer bar mounting bracket ...	B8S-5486-PR	25.95 pair
-------------------------------------------	-------------	------------

## Stabilizer Bar End Repair Kits (2 kits required)



58-60 One kit does one end .....	B8SZ-5A486-KT	10.95 kit
61-66 11 pieces, one kit does one end .....	C1SZ-5A486-KT	8.95 kit

## Stabilizer Bar Bushings (2 required)

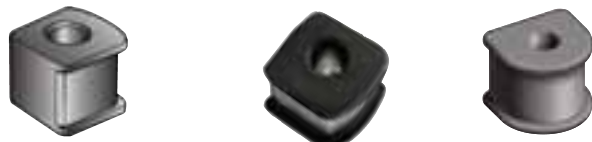

1959 8 cylinder 430 .....	B7A-5493-B	5.95
58-60 8 cylinder 352 .....	B9S-5493-A	7.95
61-66 .....	B9A-5493-B	8.95



## Rear Axle Grease Seals (2 required)



58-60	1-1/2" ID x 2-1/2" OD	B7A-1177-A	4.95
1961	1-3/8" ID x 2-3/8" OD (shown)	B7A-1177-B	6.95
62-66	1-1/2" ID x 2-1/2" OD	B7A-1177-A	4.95

## Rear Wheel Bearings, Gaskets & Retainer (2 required)



58-66	Rear wheel bearing, stamped 88128, 1-17/32" ID x 3-5/32" OD	C1SZ-1225-B	29.95
<i>Some '61s used a smaller bearing. Be sure to get stamping # or have measurement ready when you call.</i>			
1961	Rear wheel bearing, stamped RW207CE or F207AKK29, 1-3/8" ID x 2-53/64" OD	B7AZ-1225-A	29.95
58-60	Rear wheel bearing gasket	C5AZ-1001-A	1.95
62-66	Rear wheel bearing gasket	C5AZ-1001-A	1.95



1961	Gasket for rear wheel bearing retainer	A8AZ-1001-A	1.95
------	-------------------------------------------	-------------	------

## Rear Axle Cover Gasket

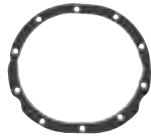

58-66	Rear axle cover gasket	B7A-4035-A	3.95
-------	------------------------	------------	------

## Differential Ring & Pinion

58-66	9" ring gear, 3.25 ratio	B8AZ-4209-C	362.95
-------	--------------------------	-------------	--------

## Differential Pinion Shaft

58-66	<i>Genuine Ford</i>	B7AZ-4211-A	27.95
-------	---------------------	-------------	-------

## Differential Bearing & Race Sets (2 sets required)



58-66	Large, bearing # LM603049 & race # LM603011	B7A-4221-B	19.95 set
61-64	Medium, bearing # LM501349 & race # LM501310	B7A-4221-A	19.95 set

## Rear Axle Pinion Bearing Set (2 sets required)



58-66	Front or rear	B7A-4616-ST	20.95 set
-------	---------------	-------------	-----------

## Rear Axle Pinion Bearing Retainer

60-66	<i>Genuine Ford</i>	B7AZ-4627-A	3.95
-------	---------------------	-------------	------

## Pinion Bearing Spacer, Crush Collar



58-66	<i>Genuine Ford</i>	B7A-4662-A	7.95
-------	---------------------	------------	------

## Rear Axle Pinion Bearing Retainer "O" Ring

58-66	4-3/4" ID, <i>Genuine Ford</i>	B7A-4669-B	3.95
-------	--------------------------------	------------	------

## Rear Axle Pinion Oil Seal & Slinger



1958	<b>NEW</b> Rear axle pinion oil seal, 4-1/8" OD	B8A-4676-A	11.95
58-62	Rear axle pinion oil seal, 3" OD	B8A-4676-B	11.95

58-66	Pinion shaft oil slinger, <i>Genuine Ford</i>	C3AZ-4670-A	2.95
-------	--------------------------------------------------	-------------	------

## Rear Axle Bumpers



58-60	Rubber (3 required)	B8S-5783-A	7.95
58-64	Rubber (2 required)	B9S-4730-A	7.95
61-64	Rubber (2 required)	B8S-5783-A	7.95

## "U" bolt (2 required)



58-66	For installing universal joints, <i>Genuine Ford</i>	D8UZ-4529-C	11.95
-------	---------------------------------------------------------	-------------	-------

## Universal Joints



58-61	Front & rear (2 required)	.4635-UJ680	16.95
1962	Front	.4635-UJ740	16.95
1962	Rear	.4635-UJ674	16.95
63-66	Front & rear (2 required)	.4635-UJ754	16.95

# MOUNTS



## Motor Mounts

Can there be a more overworked or more under appreciated part of your Ford than the lowly motor or transmission mount? Every time we rev our high-powered Ford engines, the poor mounts are stretched almost to the point of tearing apart. Every little oil leak seems to find its way to the sensitive rubber part of every mount, while exhaust & engine heat combine to cook mounts into an early grave. Yet, these motor & transmission mounts have the vital tasks of keeping our drive trains properly centered & safely anchored under every condition, while also isolating engine vibrations from the chassis & passenger compartment. Have a heart & replace those worn & weakened motor & transmission mounts today!

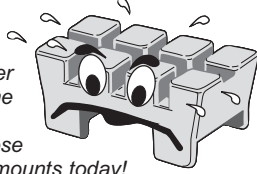

58-63 Motor mount, V-8, **except** 430, right or left (2 required) . . . . . C6VY-6038-C 17.95

59-60 Motor mount, 430 engine (2 required) . . . . . B9S-6038 50.95



64-66 Motor mount, with Cruise-O-Matic transmission, right. . . . . C4SZ-6038-CR 37.95

64-66 Motor mount, with Cruise-O-Matic transmission, left. . . . . C4SZ-6038-DR 37.95

1966 Motor mount, V-8 390 & 428, C6 transmission only, right or left (2 required) . . . . . C6VY-6038-C 17.95

## Motor Mount Parts

59-60 Bracket, 430, right or left (2 required) . . . . . B9S-6028-A 47.95



61-63 Bracket, right (2 required) . . . . . C1SS-6028-B 37.95

61-63 Bracket, left (2 required) . . . . . C1SS-6029-B 37.95



64-66 Bracket, right (2 required) . . . . . C4SZ-6028-A 37.95

64-66 Bracket, left (2 required) . . . . . C4SZ-6029-A 37.95

59-60 Insulator, for front motor mount, 430 engine (2 required) . . . . . B9S-6039-A 7.95

## Motor Mount Heat Shield

58-66 Used only on the left side . . . . . C1SS-6035 14.95

## Transmission Mounts

58-60 Retainer, **except** 430 . . . . . B7A-6054-A 27.95



58-60 **Except** 430 (shown) . . . . . B8S-6068-A 23.95

59-60 430 engine . . . . . B9S-6068-A 50.95



61-63 . . . . . C2SZ-6068-AR 24.95

64-66 With Cruise-O-Matic transmission . . . . . C3AZ-6068-C 18.95

1966 C6 transmission only. . . . . C6SZ-6068-D 14.95

# EXHAUST

## Smithy's Mufflers

Now you too can have that nostalgic mellow tone that only a Smithy's muffler produces. With a beautiful hammer tone finish, 3-1/2" case diameter & a 2" inlet & outlet, not only do they look great, they are available in 3 lengths to fit virtually any car or truck in your stable.



ALL 22" case (as required) . . . . . H3010 39.95  
ALL 22" case, sold as a pair . . . . . H3010PR 70.95 pair

ALL 26" case (as required) . . . . . H3011 43.95  
ALL 26" case, sold as a pair . . . . . H3011PR 78.95 pair

ALL 30" case (as required) . . . . . H3012 45.95  
ALL 30" case, sold as a pair . . . . . H3012PR 83.95 pair



ALL "Smithy's" muffler decal, show everyone why your V-8 sounds so good! . . . . . DZ309 4.95

## Exhaust Manifold Choke Plate

58-66 Includes gasket & bolt, this is the flat piece of steel that attaches to the backside of the right exhaust manifold. . . . . B8AZ-9A705 14.95

## Exhaust Hangers & Parts

61-63 Hanger, this is the loop & bracket part for the rear muffler, used on all 61-62 but only used with dual exhaust in 1963. . . . . C1SZ-5260-PR 50.95 pair

61-63 Hanger, right, used where the pipe goes over the axle, used on all 61-62 but only used with dual exhaust in 1963. . . . . C1SZ-5A246-B 50.95

61-63 Hanger, left, used where the pipe goes over the axle, used on all 61-62 but only used with dual exhaust in 1963. . . . . C1SZ-5A246-C 50.95

61-63 Exhaust bracket & bushing, includes thru bolt & lock nut, used at the back of the muffler, from 6-20-61 (2 required) . . . . . C4SZ-5260-C 16.95

64-66 Hanger, this is the loop & bracket part for the rear muffler . . . . . C4SZ-5260-PR 50.95 pair

64-66 Exhaust bracket & bushing, includes thru bolt & lock nut, used at the front & the back of the muffler (4 required) . . . . . C4SZ-5260-C 16.95





## Front Coil Springs

58-60	V-8 352	B8SZ-5310-A	149.95 pair
58-60	V-8 352 with A/C	B8SZ-5310-B	149.95 pair
59-60	V-8 430	B9SZ-5310-A	149.95 pair
59-60	V-8 430 with A/C	B9SZ-5310-B	149.95 pair
61-62		C1SS-5310-A	169.95 pair
61-62	With A/C	C1SS-5310-B	169.95 pair
1963		C3SZ-5310-A	169.95 pair
1963	With A/C	C3SZ-5310-B	169.95 pair
64-66		C4SZ-5310-A	205.95 pair
64-65	With A/C	C4SZ-5310-B	169.95 pair
1966	With A/C	C6SZ-5310-BC	205.95 pair

## Spring Saddle Bushing & Brackets Kit (2 kits required)



61-62	Bushing kit, 12 pieces	C1SZ-5A322-KT	55.95 kit
61-62	<b>NEW</b> Bracket kit, 4 pieces	C1SS-5A308-KT	31.95 kit

## Coil Spring Insulators



58-60	Rubber, upper only (2 required)	B8A-5415-A	4.95
61-66	Rubber, upper & lower, 1 pair does 1 spring (2 pair required)	C1SZ-5415-PR	12.95 pair

## Rear Coil Springs

1958		B8S-5560-A	164.95 pair
------	--	------------	-------------

## Rear Leaf Springs

MAC's leaf springs are manufactured from the highest quality SAE 5160 high alloy spring steel using original patterns from the Ford Motor Company. Each pair is made to order for your car.

**There is a \$50.00 flat rate shipping fee in the continental U.S.**



Please Be Prepared With The Following Information When Ordering Leaf Springs:



- Is your car a Hardtop or a Convertible?
- Is your car equipped with Air Conditioning or not?
- For 1959-1960: Which engine do you have, a 352 or a 430?
- For 1966: Which engine do you have, a 390 or a 428?

1959		LEAF-5560-A	550.95 pair
60-66		LEAF-5560-B	571.95 pair

## Leaf Spring Clamp Kit & Liner Set



59-66	Clamp kit, includes 1 two-piece clamp & 2 liners (6 required)	C4DZ-5724-A	10.95 kit
59-66	<b>NEW</b> Clamp liner set, 6 pieces (2 required)	8A-5334-ST	7.95 set

## Rear Leaf Spring Center Pads (4 required)

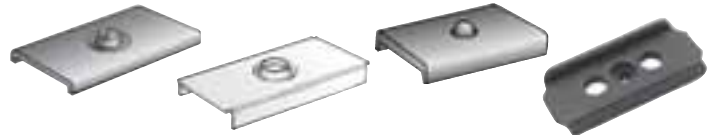

59-60	Rubber, spring uses 2 pads	AB-5741-A	9.95
59-60	Retainer, steel	B2AZ-5736-A	7.95
1961	Rubber, spring uses 2 pads	C1SS-5741-A	13.95
62-66	Rubber, spring uses 2 pads	C2SZ-5741-BR	11.95

## Leaf Spring U-Bolt & Nuts



59-61	<b>NEW</b> U-bolt, includes 2 nuts (4 required)	B7A-5705-A	6.95
59-61	<b>NEW</b> U-bolt special nut (8 required)	B7A-5705-NUT	1.95

## Leaf Spring Anti-Squeak (as required)



59-60	Teflon replacement type, round with button in the center	B8A-5586-A	1.95
61-66	<b>NEW</b> Hexagon shaped	COAA-5586-B	2.95

## Poly Slide Leaf Spring Liners (as required)

With all the time & effort you put into restoring your car don't let something little like a squeak ruin your finished product! Use our Poly Slide Leaf Spring Liners to help fix that problem. A classic car is a beautiful thing, so get rid of that squeak in your spring! Call MAC's & order yours today!

A Highly Recommended, Must-Have Item!!



58-66	1-3/4" wide x 20' long	A5310PS1	9.95 roll
58-66	2" wide x 20' long	A5310PS2	10.95 roll
58-66	2-1/4" wide x 20' long	A5310PS3	11.95 roll



## Shackle Kits & Bushings

- 59-60 **NEW** Shackle kit, for front of leaf spring (2 kits required) (shown) . . . B7A-5630-C 16.95 kit
- 59-60 Shackle kit, for rear of leaf spring (2 kits required) . . . . . COAZ-5630-B 12.95 kit



- 62-63 Shackle kit, for rear of leaf spring (2 kits required) . . . . . C2SZ-5630-B 27.95 kit
- 64-66 Shackle kit, for rear of leaf spring (2 kits required) . . . . . C4SZ-5630-B 47.95 kit



- 59-60 Bushing, for rear of leaf spring (8 required) . . . . . COAB-5781-A 1.95
- 61-63 Bushing, for rear of leaf spring (8 required) . . . . . C1AZ-5781-A 4.95
- 64-66 Upper bushing, for rear leaf spring rear shackle (4 required) . . . . . C4SA-5791-A 5.95
- 64-66 Lower bushing, for rear leaf spring rear shackle (4 required) . . . . . C1VV-5791-B 5.95

## Spring Eye Bushings



- 1959 **NEW** For front of leaf spring (2 required) . . . . . MG-5781-A 15.95
- 1962 For front of leaf spring (4 required) . . . . . C3AA-5781-A 18.95
- 63-66 For front of leaf spring (4 required) . . . . . C3SZ-5781-A 7.95

## Spring Bumper (2 required)



- 59-60 **NEW** Mounts on bracket above center of spring . . . . . B7A-5783 5.95

## Lower Front Shock Mount (2 required)



- 63-66 **NEW** Bolts to upper control arm . . C3SZ-18183-A 20.95

## Gravel Guard (2 required)

Originally 61-63 rear shocks had a gravel guard to protect them. You can recreate that look for less than 10 bucks! Just call & we'll send them out right away.



- 61-63 Rear shock absorber gravel guard . . B5S-18125-A 4.95

## Front Shock Absorbers

**Gas-Charged (1 year warranty.)**

- 58-60 MONRO-MATIC PLUS, mounts inside coil spring, heavy-duty (2 required) . . . . . B7A-18124-M 27.95
- 61-62 CURE-RIDE . . . . . C1SZ-18124-CG 74.95 pair
- 1963 CURE-RIDE . . . . . C3SZ-18124-CG 74.95 pair
- 64-66 CURE-RIDE . . . . . C4SZ-18124-CG 74.95 pair

## Front Shock Absorber Bushings (2 required)

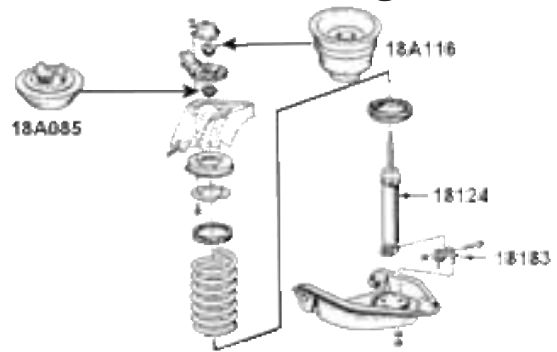

- 64-66 Bushing, upper . . . . . C4SZ-18A085-A 11.95
- 64-66 Mount bushing, upper . . . . . C4SZ-18A116-A 11.95

## Rear Shock Absorbers

**Gas-Charged (1 year warranty.)**



TYPICAL CURE-RIDE

- 1958 CURE-RIDE . . . . . B8S-18125-CG 74.95 pair
- 59-60 CURE-RIDE . . . . . B9S-18125-CG 74.95 pair



- 61-63 **Motorcraft**, heavy-duty (2 required) . . B2A-18125-F 35.95

- 61-63 MONRO-MATIC PLUS, heavy-duty (2 required) . . . . . B2A-18125-M 27.95
- 64-66 CURE-RIDE . . . . . C4SZ-18125-CG 74.95 pair

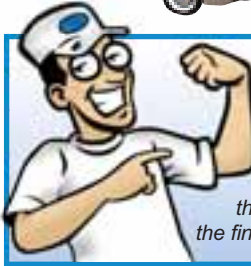

**PUT THE POWER BACK IN YOUR FORD ENGINE!**

Restore the kind of power that Ford Motor Co. engines are famous for, with new top-quality replacement parts.

MAC's sells parts **ONLY** for Ford & Mercury engines & our years of experience have discovered the parts that will work best for your car. We have searched for the finest quality components & for sources that will allow us

to offer you excellent pricing. Get the pistons, valves, timing sets, camshafts, rings, oil pumps, cylinder sleeves, bearings, gasket sets & other parts that you need for a top-notch engine restoration.

So, whether you have a 352, a 390 or even a 430 V-8, call MAC's today!

**How many do I need to order? All engine components listed are sold "each" except:**

**SET**— 1 set does one engine (piston rings, camshaft bearings & main bearings).

**PAIR**—1 pair makes one unit (split items, such as connecting rod bearings = order one pair for each connecting rod & valve keepers = order on pair for each valve stem).

All other items are sold **EACH**—count how many your car uses now (pistons, camshafts, cylinder sleeves, etc.).



**1958-1960 352 V-8**

**Cylinder Head Dowel Set**

**NEW** 4-piece set ..... B9AE-6A008-A 4.95 set

**Cast Iron Ring Sets**

Comp size .078 & .093, oil size .187.

Standard ..... B8AZ-6149-A 44.95 set  
.030 oversize ..... B8AZ-6149-D 44.95 set  
.060 oversize ..... B8AZ-6149-G 44.95 set

**Rod Bearings (8 pair required)**

Standard shaft size 2.4380 / 2.4388 ..... C6AZ-6211-A 6.95 pair  
.002 oversize ..... C6AZ-6211-T 6.95 pair  
.010 oversize ..... C6AZ-6211-B 6.95 pair  
.020 oversize ..... C6AZ-6211-C 6.95 pair  
.030 oversize ..... C6AZ-6211-D 6.95 pair

**Aluminum Pistons With Pin (8 required)**

Standard, pin diameter .975 ..... COAZ-6108-A 36.95  
.020 oversize ..... COAZ-6108-C 36.95  
.030 oversize ..... COAZ-6108-D 36.95  
.040 oversize ..... COAZ-6108-E 36.95  
.060 oversize ..... COAZ-6108-G 36.95

**Intake Valve (8 required)**

Stem diameter .3716 +/- .0005.

Standard, 1960 only ..... COAZ-6507-A 11.95

**Intake Seat (8 required)**

Hi-chrome steel, heavy duty ..... C6AZ-6057-B 4.95

**Intake Valve Guides (8 required)**

All are standard OD with a .374 ID.

Plain ..... C6AZ-6510-A 1.95  
Spiral groove ..... C6AZ-6510-B 1.95

**Exhaust Valves (8 required)**

Stem diameter .3715 +/- .0005.

Standard size, heavy duty, 5.436" long. .... D7TZ-6505-A 5.95  
.015 oversize, heavy duty ..... D7TZ-6505-C 5.95

**Exhaust Seat (8 required)**

Hi-chrome steel, heavy duty ..... B8A-6057-F 4.95

**Exhaust Valve Guides (8 required)**

All are standard OD.

Plain, .374 ID. .... C6AZ-6510-A 1.95  
Spiral groove, .374 ID ..... C6AZ-6510-B 1.95  
Plain, .373 ID. .... C6AZ-6510-G 1.95

**Valve Spring Insert, Shims (as required)**

.030 thickness ..... B8AZ-6515-A 0.95  
.060 thickness ..... B8AZ-6515-B 0.95

**Valve Springs (16 required)**

Intake ..... B8A-6513-C 1.95  
Exhaust ..... B8A-6513-B 2.95

**Valve Lifters (16 required)**

Hydraulic ..... C8AZ-6500-A 5.95  
Mechanical ..... C4AZ-6500-B 5.95

**Moly Ring Sets**

Comp size .078 & .093, oil size .187.

Standard ..... B8AZ-6149-MA 60.95 set  
.020 oversize ..... B8AZ-6149-MC 60.95 set  
.030 oversize ..... B8AZ-6149-MD 60.95 set  
.040 oversize ..... B8AZ-6149-ME 60.95 set

**Chrome Ring Set**

Comp size .078 & .093, oil size .187, chrome ring sets have limited availability.

.030 oversize ..... B8AZ-6149-CD 42.95 set

**Cylinder Sleeves (8 required)**

Nominal bore 4.000, length 6.250.

3/32" wall ..... B8AZ-6055-A 23.95  
1/8" wall ..... B8AZ-6055-B 23.95

**Camshaft**

Hydraulic ..... B8A-6250-B 161.95

**Push Rods (16 required)**

1958 With hydraulic lifters ..... B8AZ-6565-C 2.95  
58-59 Both ends oval ..... C8AZ-6565-A 2.95  
1960 With hydraulic lifters ..... C4TZ-6565-B 1.95

**Rocker Arm Shafts (2 required)**

With adjustable rocker arms ..... COAZ-6563-A 25.95  
With non-adjustable rocker arms ..... COAZ-6563-A 25.95

**Rocker Arm (16 required)**

Rocker arms have limited availability.

With hydraulic lifters ..... B8AZ-6564-C 16.95  
Rocker arm shaft support ..... C2AZ-6531-B 12.95

**1961-1965 390 V-8**

**Cylinder Head Dowel Set**



**NEW** 4-piece set ..... B9AE-6A008-A 4.95 set

**Rod Bearings (8 pair required)**

Standard shaft size 2.4380/ 2.4388 ..... C6AZ-6211-A 6.95 pair  
.002 oversize ..... C6AZ-6211-T 6.95 pair  
.010 oversize ..... C6AZ-6211-B 6.95 pair  
.020 oversize ..... C6AZ-6211-C 6.95 pair  
.030 oversize ..... C6AZ-6211-D 6.95 pair

**1964-1965 Main Bearing Sets**

Standard shaft size 2.7484/ 2.7492 ..... C4TZ-6333-A 72.95 set  
.002 oversize ..... C4TZ-6333-T 72.95 set  
.010 oversize ..... C4TZ-6333-B 72.95 set  
.020 oversize ..... C4TZ-6333-C 72.95 set  
.030 oversize ..... C4TZ-6333-D 72.95 set

**Camshafts**

Hydraulic, 1961-1962 ..... B8A-6250-B 161.95  
Hydraulic, 1963-1965 ..... C3YZ-6250-A 131.95





**1966 390 V-8**

**Cylinder Head Dowel Set**



**NEW** 4-piece set . . . . . B9AE-6A008-A 4.95 set

**Cast Iron Ring Sets**

Please verify ring thickness. Comp size .078, oil size .187.  
Use with original pistons only.

Standard . . . . . C6MY-6149-A 33.95 set  
.020 oversize . . . . . C6MY-6149-C 33.95 set  
.030 oversize . . . . . C6MY-6149-D 33.95 set

**Rod Bearings (8 pair required)**

Shaft size 2.4380/ 2.4388.

Standard . . . . . C6AZ-6211-A 6.95 pair  
.002 oversize . . . . . C6AZ-6211-T 6.95 pair  
.010 oversize . . . . . C6AZ-6211-B 6.95 pair  
.020 oversize . . . . . C6AZ-6211-C 6.95 pair  
.030 oversize . . . . . C6AZ-6211-D 6.95 pair

**Intake Valves (8 required)**

Stem diameter .3715 +/- .00035.

Standard . . . . . D4TZ-6507-A 4.95  
.015 oversize . . . . . D4TZ-6507-C 4.95

**Intake Seat (8 required)**

Hi-chrome steel, heavy duty . . . . . C6AZ-6057-B 4.95

**Intake Valve Guides (8 required)**

Standard OD, plain, .374 ID . . . . . C6AZ-6510-A 1.95  
Standard OD, spiral groove, .374 ID . . . . . C6AZ-6510-B 1.95

**Exhaust Seat (8 required)**

Hi-chrome steel, heavy duty . . . . . B8A-6057-F 4.95

**Exhaust Valve Guides (8 required)**

Standard OD, plain, .374 ID . . . . . C6AZ-6510-A 1.95  
Standard OD, spiral groove, .374 ID . . . . . C6AZ-6510-B 1.95  
Standard OD, plain, .373 ID . . . . . C6AZ-6510-G 1.95

**Heavy-duty Exhaust Valves (8 required)**

Stem diameter, .3715 +/- .0005 overall length is 5.436.

Standard . . . . . D7TZ-6505-A 5.95  
.015 oversize . . . . . D7TZ-6505-C 5.95

**Valve Spring Insert, Shims (as required)**

.030 thickness . . . . . B8AZ-6515-A 0.95  
.060 thickness . . . . . B8AZ-6515-B 0.95

**Valve Spring (16 required)**

Intake & exhaust . . . . . C1AZ-6513-B 3.95

**Valve Lifter (16 required)**

Hydraulic . . . . . C8AZ-6500-A 5.95

**Aluminum Piston With Pin (8 required)**

Use with 1961-1965 ringsets only.

.020 oversize . . . . . C6SZ-6108-C 18.95

**Main Bearing Sets**

Shaft size 2.7484/ 2.7492

Standard . . . . . C4TZ-6333-A 72.95 set  
.002 oversize . . . . . C4TZ-6333-T 72.95 set  
.010 oversize . . . . . C4TZ-6333-B 72.95 set  
.020 oversize . . . . . C4TZ-6333-C 72.95 set  
.030 oversize . . . . . C4TZ-6333-D 72.95 set

**Camshaft**

Hydraulic . . . . . C6AZ-6250-A 115.95

**Cam Bearing Set**

Standard size . . . . . C6AZ-6A251-A 26.95 set

**Push Rod (16 required)**

With hydraulic lifters . . . . . C4TZ-6565-B 1.95

**Rocker Arm Shaft (2 required)**

Standard replacement . . . . . COAZ-6563-A 25.95  
Rocker arm shaft support . . . . . C2AZ-6531-B 12.95

**Rocker Arm (16 required)**

Non-adjustable, for hydraulic lifters . . . . . B8AZ-6564-C 16.95

How many do I need to order? All engine components listed are sold "each" except:

**SET**—1 set does one engine (piston rings, camshaft bearings & main bearings).

**PAIR**—1 pair makes one unit (split items, such as connecting rod bearings = order one pair for each connecting rod & valve keepers = order on pair for each valve stem).

All other items are sold **EACH**—count how many your car uses now (pistons, camshafts, cylinder sleeves, etc.).



**1962-1963 with 3x2 bbl**

**Cylinder Head Dowel Set**

**NEW** 4-piece set . . . . . B9AE-6A008-A 4.95 set

**Intake Valve (8 required)**

Stem diameter, .3716 +/- .0035.

Standard . . . . . COAZ-6507-A 11.95

**Heavy-duty Exhaust Valves (8 required)**

Stem diameter, .3715 +/- .0005 overall length is 5.436.

Standard . . . . . D7TZ-6505-A 5.95  
.015 oversize . . . . . D7TZ-6505-C 5.95

**Exhaust Valve Guides (8 required)**

Standard OD, plain, .374 ID . . . . . C6AZ-6510-A 1.95  
Standard OD, spiral groove, .374 ID . . . . . C6AZ-6510-B 1.95  
Standard OD, plain, .373 ID . . . . . C6AZ-6510-G 1.95

**Valve Spring Inserts, Shims (as required)**

.030 thickness . . . . . B8AZ-6515-A 0.95  
.060 thickness . . . . . B8AZ-6515-B 0.95

**Aluminum Pistons With Pin (8 required)**

Standard, pin diameter .975 . . . . . C1AZ-6108-A 27.95  
.020 oversize . . . . . C1AZ-6108-C 27.95  
.030 oversize . . . . . C1AZ-6108-D 27.95  
.040 oversize . . . . . C1AZ-6108-E 27.95

**Cam Bearing Set**

Standard size . . . . . C6AZ-6A251-A 26.95 set

**1961-1965 without 3x2 bbl**

**Cylinder Head Dowel Set**

**NEW** 4-piece set . . . . . B9AE-6A008-A 4.95 set

**Carburetors Intake Valves (8 required)**

Stem diameter .3715 +/- .0035.

Standard, stem diameter . . . . . D4TZ-6507-A 4.95  
.015 oversize . . . . . D4TZ-6507-C 4.95

**Intake Valve Guides (8 required)**

Standard OD, plain, .374 ID . . . . . C6AZ-6510-A 1.95  
Standard OD, spiral groove, .374 ID . . . . . C6AZ-6510-B 1.95

**Heavy Duty Valve Seats (8 required)**

Hi-chrome steel, intake . . . . . C6AZ-6057-B 4.95  
Hi-chrome steel, exhaust . . . . . B8A-6057-F 4.95

**Valve Lifters (16 required)**

Hydraulic . . . . . C8AZ-6500-A 5.95  
Mechanical . . . . . C4AZ-6500-B 5.95

**Push Rods (16 required)**

1961 thru 12-23-63, with hydraulic lifters . . . . . C8AZ-6565-A 2.95  
12-23-63 thru 1965, with hydraulic lifters . . . . . C4TZ-6565-B 1.95

**Rocker Arm Shaft (2 required)**

Standard replacement . . . . . COAZ-6563-A 25.95

**Rocker Arm (16 required)**

Non-adjustable, use with hydraulic lifters . . . . . B8AZ-6564-C 16.95  
Rocker arm shaft support . . . . . C2AZ-6531-B 12.95



**1966 428 V-8**

**Cylinder Head Dowel Set**



**NEW** 4-piece set ..... B9AE-6A008-A 4.95 set

**Cast Iron Ring Set**

Comp size .078, oil size .187.

.020 ..... C6AZ-6149-C 50.95 set

**Rod Bearings (8 pair required)**

Standard shaft size 2.4380/ 2.4388 ..... C6AZ-6211-A 6.95 pair  
.002 oversize ..... C6AZ-6211-T 6.95 pair  
.010 oversize ..... C6AZ-6211-B 6.95 pair  
.020 oversize ..... C6AZ-6211-C 6.95 pair  
.030 oversize ..... C6AZ-6211-D 6.95 pair

**Aluminum Pistons With Pin (8 required)**

Pin diameter .975, .700 ID.

Standard ..... C7AZ-6108-A 50.95  
.020 oversize ..... C7AZ-6108-C 50.95  
.030 oversize ..... C7AZ-6108-D 50.95  
.060 oversize ..... C7AZ-6108-G 50.95

**Intake Valve Guides (8 required)**

Standard OD, plain, .374 ID ..... C6AZ-6510-A 1.95  
Standard OD, spiral groove, .374 ID ..... C6AZ-6510-B 1.95

**Exhaust Valves (8 required)**

Stem diameter .3713 +/- .0005, length 5.436.

Standard, 5.436" long ..... D7TZ-6505-A 5.95  
.015 oversize ..... D7TZ-6505-C 5.95

**Exhaust Seat (8 required)**

Hi-chrome steel, heavy duty ..... B4AZ-6510-C 1.95

**Exhaust Valve Guides (8 required)**

Standard OD, plain, .374 ID ..... C6AZ-6510-A 1.95  
Standard OD, spiral groove, .374 ID ..... C6AZ-6510-B 1.95  
Standard OD, plain, .373 ID ..... C6AZ-6510-G 1.95

**Valve Spring Inserts, Shims (as required)**

.030 thickness ..... B8AZ-6515-A 0.95  
.060 thickness ..... B8AZ-6515-B 0.95

**Valve Springs (16 required)**

Intake with damper ..... C3AZ-6513-BE 3.95  
Exhaust with damper ..... C3AZ-6513-BE 3.95

**Valve Lifter (16 required)**

Hydraulic ..... C8AZ-6500-A 5.95

**Cylinder Sleeves (8 required)**

Nominal bore 4.125, length 6.375.

3/32 wall ..... C6AZ-6055-A 26.95  
1/8 wall ..... C6AZ-6055-B 24.95

**Main Bearing Sets**

Standard shaft size 2.7484/ 2.7492 ..... C4TZ-6333-A 72.95 set  
.002 oversize ..... C4TZ-6333-T 72.95 set  
.010 oversize ..... C4TZ-6333-B 72.95 set  
.020 oversize ..... C4TZ-6333-C 72.95 set  
.030 oversize ..... C4TZ-6333-D 72.95 set

**Cam Bearing Set**

Standard size ..... C6AZ-6A251-A 26.95 set

**Camshaft**

Hydraulic ..... C6AZ-6250-A 115.95

**Push Rod (16 required)**

With hydraulic lifters ..... C4TZ-6565-B 1.95

**Rocker Arm Shaft (2 required)**

Standard replacement ..... COAZ-6563-A 25.95

**Rocker Arm (16 required)**

Non-adjustable ..... B8AZ-6564-C 16.95

**1959 - 1960 430 V-8**

**Valve Spring Inserts, Shims (as required)**

.030 thickness ..... B8AZ-6515-A 0.95  
.060 thickness ..... B8AZ-6515-B 0.95

**Valve Lifter (16 required)**

Hydraulic ..... C8AZ-6500-A 5.95

**Main Bearing Set**

.002 oversize ..... C1VE-6333-T 144.95 set

**Cam Bearing Set**

Standard size ..... COSZ-6A251-A 33.95 set

**Rod Bearing (8 pair required)**

Standard, shaft size 2.5992/ 2.600 ..... C1VE-6211-A 24.95 pair

**Push Rod (16 required)**

Standard ID, stock length ..... C3SZ-6565-A 3.95

**Rocker Arm (16 required)**

Cast ..... B8AZ-6564-C 16.95  
Rocker arm shaft support ..... C2AZ-6531-B 12.95

**Soft Plug Sets**



58-66 **NEW** Steel set, for 352, 390 & 428 ..... C3AZ-6026-STEEL 3.95 set



58-66 **NEW** Brass set, for 352, 390 & 428 ..... C3AZ-6026-BRASS 13.95 set



With all of the vibration, stress & pressure, it is a wonder that any timing set can survive within a T-Bird engine short-block assembly. Part of the problem is the fact that the original engine designers must create an engine that will keep everyone happy.

Therefore, they design a timing set with plastic gears & a light-

duty timing chain, so it will be very quiet & rather mellow for folks in their "golden years." On the other hand, these parts must also hold up under performance conditions with younger drivers.

**What is the best solution for restorers & rebuilders? Call the restoration Pro's at MAC's Antique Auto Parts & order the engine parts that will best fit your needs!**

**Timing Gears & Chains**

**352 V-8 (1958-1960)**

58-60	Camshaft gear, 36 teeth	B8A-6256-A	29.95
58-60	Crankshaft gear, 18 teeth	B8A-6306-A	15.95
58-60	Timing chain	DOAZ-6268-A	17.95

**390 V-8 (1961-1966)**

61-62	Camshaft gear, 36 teeth	B8A-6256-A	29.95
63-66	Camshaft gear, iron, 36 teeth, camshaft nose spacer cast into hub	C8AZ-6256-AI	17.95
63-66	Camshaft gear, nylon, 36 teeth, camshaft nose spacer cast into hub	C8AZ-6256-AN	22.95
61-63	Crankshaft gear, 18 teeth	B8A-6306-A	15.95
64-66	Crankshaft gear, 18 teeth	C4AZ-6306-A	8.95
61-66	Timing chain	DOAZ-6268-A	17.95
64-66	Timing set, 3 pieces: iron camshaft gear, crankshaft gear & timing chain, camshaft nose spacer cast into hub	C4AZ-6268-ST	29.95 set

**428 V-8 (1966)**

1966	Camshaft gear, iron, 36 teeth, camshaft nose spacer cast into hub	C8AZ-6256-AI	17.95
1966	Camshaft gear, nylon, 36 teeth, camshaft nose spacer cast into hub	C8AZ-6256-AN	22.95
1966	Crankshaft gear, 18 teeth	C4AZ-6306-A	8.95
1966	Timing chain	DOAZ-6268-A	17.95
1966	Timing set, 3 pieces: iron camshaft gear, crankshaft gear & timing chain, camshaft nose spacer cast into hub	C4AZ-6268-ST	29.95 set

**430 V-8 (1959-1960)**

59-60	Camshaft gear, 40 teeth	B8E-6256-A	51.95
59-60	Crankshaft gear, 20 teeth	B8E-6306-A	32.95
59-60	Timing chain	C8SZ-6268-A	20.95

**Crankshaft Vibration Damper (Harmonic Balancer)**



58-66	Single groove, V-8 352, 390 & 428	C3AZ-6312-E	98.95
-------	-----------------------------------	-------------	-------

**Crankshaft Oil Slinger**



58-66	Crankshaft oil slinger, 352, 390 & 428	B8A-6310-A	4.95
-------	----------------------------------------	------------	------

**Rear Main Seal Sets**

58-66	2 pieces, V-8 352, 390 & 428, split lip type	B8AZ-6701-ST	21.95 set
59-60	V-8 430, split lip type	B8QH-6701-ST	32.95 set

**Flexplates**

58-64	153 teeth, 352 & 390, automatic transmission	B8A-6375-B	111.95
59-60	153 teeth, 430, with Cruise-O-Matic transmission	B8A-6375-B	111.95



65-66	184 teeth, 390	C5AZ-6375-D	80.95
-------	----------------	-------------	-------





**TYPICAL 8 CYLINDER GASKET & SEAL LOCATIONS**

**HEAD SET:**

- 1. AIR CLEANER MOUNTING GASKET
- 2. WATER OUTLET, THERMOSTAT HOUSING GASKET
- 3. WATER BYPASS GASKET
- 4. INTAKE MANIFOLD GASKET
- 5. VALLEY PAN GASKET
- 6. VALVE COVER GASKET
- 7. VALVE STEM SEALS
- 8. EXHAUST FLANGE GASKET
- 9. EXHAUST HEAD GASKET
- 10. CYLINDER HEAD GASKET
- 11. DISTRIBUTOR MOUNTING GASKET

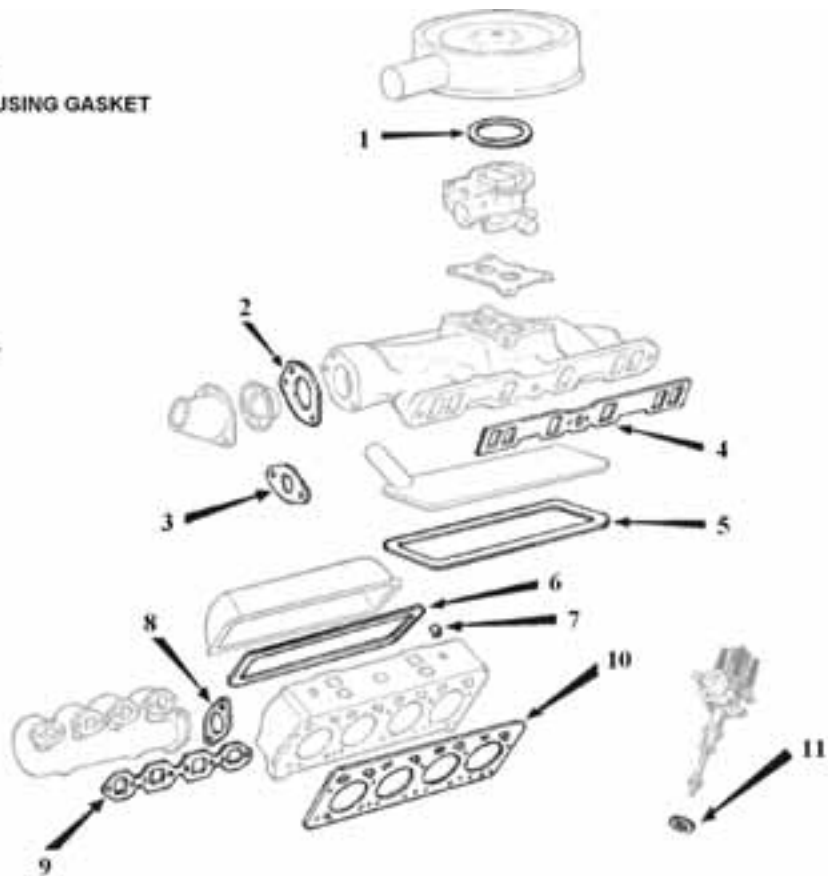

**(HEAD SET) + (CONVERSION SET) = ENGINE OVERHAUL SET**

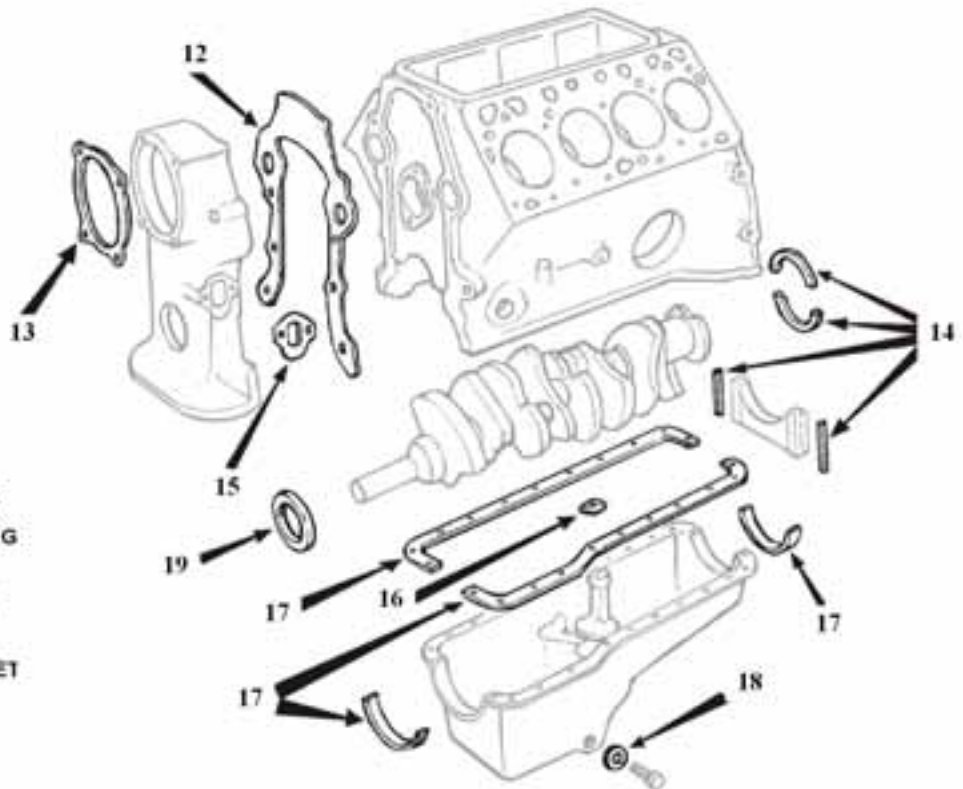

**CONVERSION SET:**

- 12. TIMING COVER GASKET
- 13. WATER PUMP MOUNTING
- 14. REAR MAIN SEALS
- 15. FUEL PUMP MOUNTING
- 16. OIL PUMP MOUNTING
- 17. OIL PAN GASKETS
- 18. OIL DRAIN PLUG GASKET
- 19. TIMING COVER SEAL



**GASKET & SEAL SET CONTENTS** (see illustration on previous page)

- Head Set : Contains all necessary gaskets & seals required to remove & replace the cylinder head(s) & to grind the valves. Does not contain carburetor, carburetor PCV adapter block, or large tin "bathtub" intake manifold gaskets.
- Valve Cover Set : Contains valve cover gasket(s) & any necessary seals or grommets required for installation.
- Timing Cover Set : Contains all gaskets & seals needed for removal & replacement of the timing cover. Will contain oil pan gasket replacement ends if the oil pan gasket must be replaced for proper installation.
- Rear Main Seal Set : Contains rear main bearing seal & any attaching part gaskets or side seals.
- Oil Pan Gasket Set : Contains oil pan gasket(s), oil drain plug gasket & oil pick-up tube gasket if required for removal & replacement of oil pan

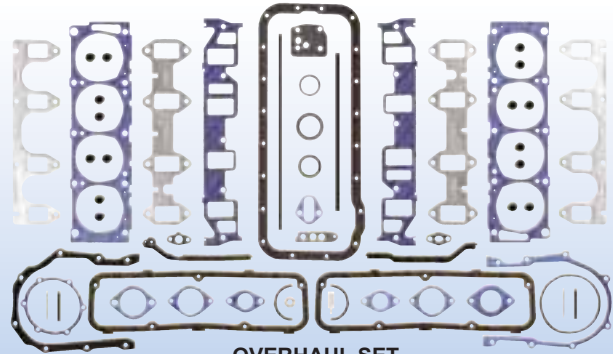

**OVERHAUL SET**

**Headset + Conversion Set = Engine Overhaul Set**

**Gasket & Seals & Sets**

**V-8, 352 Cubic Inch**

58-60	Engine overhaul set (shown) . . . . .C9AZ-6008-ST	127.95	set
58-60	Timing cover set . . . . .COAE-6020-ST	17.95	set
58-60	Head gasket . . . . .B8AZ-6051-A	23.95	
58-60	Head set . . . . .B8AZ-6079-ST	97.95	set
58-60	Valve cover set, cork . . . . .DOAZ-6584-CST	14.95	set
58-60	Valve cover set, rubber . . . . .DOAZ-6584-RST	19.95	set
58-60	Rear main seal set, 2 pieces . . . . .B8AZ-6701-ST	21.95	set
58-60	Oil pan gasket, cork . . . . .COAE-6710-C	14.95	

**V-8, 390 Cubic Inch**

61-66	Engine overhaul set (shown) . . . . .C9AZ-6008-ST	127.95	set
61-66	Timing cover set . . . . .COAE-6020-ST	17.95	set
61-66	Head gasket . . . . .B8AZ-6051-A	23.95	
61-66	Head set . . . . .B8AZ-6079-ST	97.95	set
61-66	Valve cover set, cork . . . . .DOAZ-6584-CST	14.95	set
61-66	Valve cover set, rubber . . . . .DOAZ-6584-RST	19.95	set
61-66	Rear main seal set, 2 pieces . . . . .B8AZ-6701-ST	21.95	set
61-66	Oil pan gasket, cork . . . . .COAE-6710-C	14.95	

**V-8, 428 Cubic Inch**

1966	Engine overhaul set (shown) . . . . .C9AZ-6008-ST	127.95	set
1966	Timing cover set . . . . .COAE-6020-ST	17.95	set
1966	Head gasket . . . . .B8AZ-6051-A	23.95	
1966	Head set . . . . .B8AZ-6079-ST	97.95	set
1966	Valve cover set, cork . . . . .DOAZ-6584-CST	14.95	set
1966	Valve cover set, rubber . . . . .DOAZ-6584-RST	19.95	set
1966	Rear main seal set, 2 pieces . . . . .B8AZ-6701-ST	21.95	set
1966	Oil pan gasket, cork . . . . .COAE-6710-C	14.95	

**V-8, 430 Cubic Inch**

59-60	Engine overhaul set . . . . .COSZ-6008-ST	174.95	set
59-60	Timing cover set, <b>except for</b> cars with crank-driven power steering. . . . .B8S-6020-ST	14.95	set
59-60	Push-rod cover set, HIGH-DENSITY FIBER. . . . .COME-6521-FST	9.95	set
59-60	Valve cover set . . . . .B9ME-6584-ST	14.95	set

**Sealers**



ALL Head gasket sealant, fills in small scratches & imperfections, eliminates hot spots & prevents seizing of connections & fittings, resists heat up to 525°, use on exhaust manifolds, cylinder head gaskets & carb base gaskets, 9 oz. spray can . . . . .RSP32 \* 8.15



ALL Permatex "Form-a-Gasket," silicone, replaces almost any cut gasket, 3 oz. tube . . . . .RSP50 4.95

\* **HAZARDOUS MATERIAL** can only be shipped by ground/surface within the U.S. because of government regulations.

ALL Gasket sealer, used to replace cork, rubber, silicone, felt & other cut gaskets to form a leak-proof seal. Resists oil, grease, water, antifreeze mixture & transmission fluid. More flexible than conventional gaskets, it can be used on water pumps, exhaust manifolds, valve covers, timing gear covers, transmission pans, water neck outlets or any place a high-performance gasket is needed, 3 oz. tube . . . . .A5251SEAL 4.95



ALL All-purpose gasket sealant, this is a general-purpose gasket maker & sealant. It works well with cork & paper gaskets, locking out fuel, anti-freeze & oil, 4 oz. can with brush in lid. . . . .RSP25 \* 5.45



**Permatex Gasket Remover**

Quickly removes all types of baked-on gaskets, adhesives & sealants.



ALL 12 oz. spray can . . . . .RSP52 \* 5.95



### ZDDPlus Motor Oil Additive

Major oil companies have been significantly reducing the level of ZDDP (zinc) in motor oil over the past few years. This vital anti-wear ingredient is necessary in all flat-tappet classic vehicle engines. By adding one bottle of ZDDP each time you change your oil, that protection will be maintained, no matter what brand or viscosity motor oil you've been using.



ALL **NEW** Oil additive, 4 oz. bottle . . . . ZDDPLUS 9.95

### Oil Pressure Sending Units

Keeping tabs on the vital fluids in your engine is important. Most of the time when the dash gauge doesn't work it's the sending unit that is at fault. Remember to use some teflon tape on the threads when you are replacing the sender, (but be sure not to let the tape extend beyond the threads & interfere with the sensor portion of the sending unit!)



58-63 . . . . . B6AZ-9278-B 7.95  
64-66 **Motorcraft**. . . . . C9ZZ-9278-A 24.95

#### Oil Sending Unit to Coil Wire

61-63 14" long . . . . . C1SF-9A282-A 6.95

#### Teflon Tape



ALL Use on the threads of the oil pressure & water temperature senders, 3/4" wide x 520" total length . . . . . TAPE 1.95

### New Oil Pump



An oil pump that works properly, circulating oil to those precious bearings as well as the rest of your drivetrain is vital to the life of your engine. The pump listed below is brand new!



58-66 352, 390 & 428 . . . . . COAZ-6600-A 49.95

### Oil Pump Rebuild Kits & Shaft

For the do-it-yourselfer we have rebuild kits, call today & get your tools ready for work! Sorry, our kits are not designed for high-performance or high-volume pumps.



58-66 Rebuild kit, 7 pieces, 352, 390 & 428 . . . . . COAZ-6600-8KT 18.95 kit  
62-63 Rebuild kit, 390 with 3x2 bbl carburetors . . . . . COAE-6600-8KT 20.95 kit  
58-66 Shaft, 352, 390 & 428 . . . . . B8AZ-6A618-A 9.95

### Oil Pump Inlet Tube Gasket

58-66 352, 390, 428 & 430 . . . . . B8AZ-6626-B 2.95

### PCV Hose, Valve & Rubber Grommet

65-66 PCV hose, formed to the correct shape, 390 only. . . . . C5AZ-6A664-C 15.95



62-64 **NEW** PCV valve. . . . . C1TZ-6A666-A 4.95  
65-66 PCV valve, 390 & 428, **Motorcraft**. . . . . DOAZ-6A666-A 5.95  
65-66 PCV valve grommet . . . . . 377394-SR 5.95

### Oil Pan, Drain Plug & Gasket

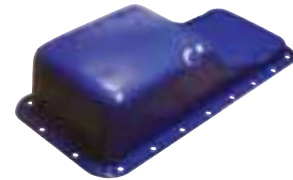

58-66 Oil pan, 390 & 428, with pan plug & nylon gasket . . . . . C6OZ-6675-A 65.95



58-66 Drain plug, 352, 390, 428 & 430, includes nylon washer. . . . . C3AZ-6730-A 2.95  
58-66 Drain plug gasket . . . . . C2OZ-6734-A 2.95

### Oil Dipsticks



In the final analysis, it will be the little detail items that will make the difference in any restored Bird. "Little parts," like the oil dip stick & oil filler cap work together to show judges & casual onlookers alike, that you have paid attention to the details. Call us now, to get the advice & parts you need to restore your fabulous car back to its original glory!

58-60 352 . . . . . COSE-6750-A 23.95  
59-60 430 . . . . . B8E-6750-A 23.95  
61-64 **Except** "M" engine (3x2 bbl carbs) . . C2SZ-6750-A 23.95  
1965 Also used on 62-63 "M" engine (3x2 bbl carbs) . . . . . C5SZ-6750-A 23.95  
1966 . . . . . C6SZ-6750-B 23.95

#### Dipstick Tubes



58-60 352 . . . . . B8A-6754-A 23.95  
61-64 . . . . . C2SZ-6754-B 22.95  
65-66 . . . . . C5SZ-6754-A 22.95

### Road Draft Tube

58-60 Crankcase ventilation tube, powder coated. . . . . B8S-6758 89.95





## Oil Filler/Breather Caps



- 58-64 As original, black push-on type . . . . . B6A-6766-A 23.95
- 58-66 Black push-on type . . . . . B7AZ-6766-A 13.95
- 58-66 Chrome push-on type,  
no logo (not shown) . . . . . B7AZ-6766-AC 14.95

## Oil Filter Mount & Gasket



- 58-66 Oil filter mount, 352, 390 & 428,  
**Genuine Ford** . . . . . COAE-6881-A 40.95
- 58-66 Oil filter mount gasket, 352, 390 &  
428 . . . . . COAZ-6A636-B 2.95

## Exhaust Manifold Bolts & Lock Tabs



From the factory, lock tabs were bent over your exhaust manifold bolts to prevent loosening. If these tabs are missing we now have the perfect solution. Buy the lock tabs by themselves or buy a complete kit with new bolts included!

- 58-66 Lock tab set, 8 pieces, right,  
352 & 390 . . . . . 9A447-AST 9.95 set
- 58-66 Lock tab set, 8 pieces, left,  
352 & 390 . . . . . 9A447-BST 13.95 set
- 58-66 **Save** Complete lock tab set,  
16 pieces, 352 & 390 . . . . . 9A447-CST 17.95 set



- 58-66 **Save** Bolt & lock kit, 352 & 390,  
32 pieces, bolts feature correct "F"  
on the head . . . . . B8AE-557 29.95 kit



- 58-66 Lock washer, part of B8AE-557 above  
(16 required) . . . . . 370383-S 1.95

## Reproduction Heat Riser Valves

These are accurate reproductions of the original complete valves.

- 58-60 352 . . . . . B9AE-9A427-A 84.95
- 1966 390 . . . . . C6SZ-9A427 95.95

## Heat Riser Spacers

Is your heat riser frozen in place? These spacer blocks replace the entire heat riser assembly, filling the gap between the manifold & header pipe & providing a less expensive alternative to a new heat riser valve. Remember, these spacers do not contain a valve & do not look original.



- 58-60 352 . . . . . B9AE-9A427-SP 22.95
- 1966 390 . . . . . C6SZ-9A427-SP 28.95

## Intake Manifold Gasket Sets



- 58-66 352, 390 & 428, 5 pieces: front gasket, rear gasket,  
2 side gaskets & distributor base gasket, port sizes are  
1-7/8" x 2-7/8" (shown) . . . . . C3AZ-9433-G 15.95 set
- 59-60 430, 3 pieces: 2 side gaskets &  
a distributor base gasket . . . . . B9S-9433-A 10.95 set

## Exhaust Manifold Gaskets

Originally Ford did not use any gasket between the exhaust manifold & the cylinder head. These are aftermarket replacements.

- 58-60 Exhaust manifold gaskets, 352 . . . . . B8A-9448-A 15.95 pair
- 59-60 Exhaust manifold gaskets, 430 . . . . . B9S-9448-A 17.95 pair

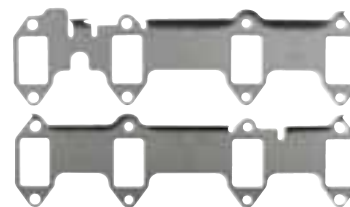

- 61-66 Exhaust manifold heat shields,  
390 & 428 . . . . . C1SZ-9448-A 16.95 pair
- 1966 Exhaust manifold gaskets,  
390 & 428, can be used with  
metal heat shields . . . . . C6AZ-9448-A 14.95 pair

## Miscellaneous Manifold Parts

- 59-60 Manifold choke tube cover plate, 430,  
made for "EDJ" manifolds, can be used  
on "B9ME" manifolds once the tab is  
removed . . . . . COME-9A705-A 12.95
- 59-60 Manifold choke tube cover plate gasket,  
carbon fiber, 430 . . . . . B9S-9903 5.95
- 58-66 Manifold choke tube cover plate kit,  
includes cover plate, gasket &  
machine screw, 352, 390 & 428 . . . 9A705-UNIV 9.95 kit

## Permatex Anti-Seize Lubricant

A blend of aluminum, copper & graphite lubricants. Perfect for easy removal of spark plugs & cylinder or exhaust head bolts.



- ALL **NEW** 1 oz. tube . . . . . RSP102 3.95



**EXCLUSIVE**

Most of the answers to the puzzle can be found within the pages of this catalog. The others are general Ford knowledge. Enjoy.

# THUNDERBIRD CROSSWORD

### ACROSS

- 6 Monroe makes these (2 words)
- 7 A major radiator manufacturer
- 11 Souped-up classic
- 13 Major bearing manufacturer
- 15 Comes in 3 speed or 4 speed
- 17 Any vehicle over 20 years old
- 19 MAC's upholstery division
- 21 Harmonic (vibration damper)
- 22 Amount of pressure applied to a bolt when tightening

### DOWN

- 1 A special type of nut.
- 2 National Street Rod Association (abr.)
- 3 A vehicle with exterior wood panels
- 4 Type of brake, or a Colorado National Park
- 5 The sweetest car show of the year is held here
- 8 Smithy's makes these
- 9 N.D.S. (3 words)
- 10 Vehicle with a retractable roof
- 12 Henry's lady (2 words)
- 14 Vehicle named for Henry's son
- 16 Pound per square inch (abr.)
- 18 A manufacturer of carburetors
- 20 Mr. Shelby

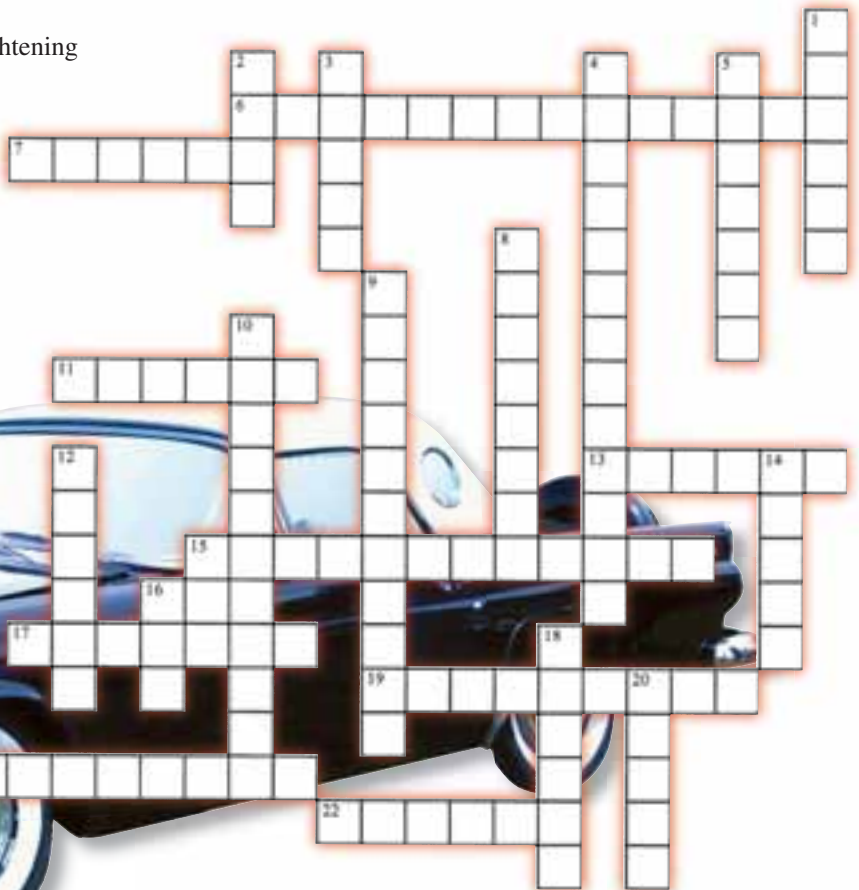

### Solution

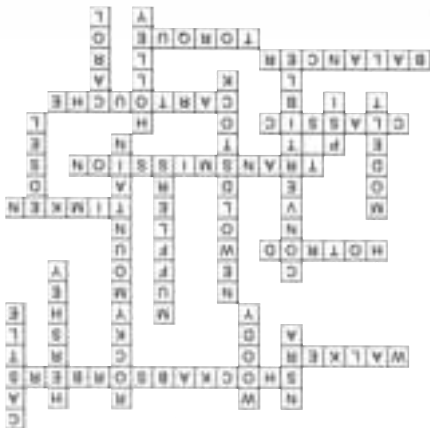



Changing your filters regularly will keep your classic running smoother, longer. We carry genuine **Motorcraft** filters as well as the popular Hastings brand for your convenience.

So plan out a Saturday morning with a cup of coffee for you, several quarts of your favorite motor oil, an oil filter, an air filter & even a fuel filter for your car.

You'll be rewarded knowing that the maintenance you do today will help to keep you from doing a much more extensive repair job down the road.

## Oil Filter

Everyone knows the importance of changing your oil regularly in your daily driver. It's important to do the same with your classic car. Nothing benefits an engine more than fresh oil & a new filter free from dirt & sludge. So give us a call, we'll be happy to send you a premium quality filter right away!



- 58-66 All engines, **Motorcraft** . . . . . C1AZ-6731-M 7.95
- 58-66 **NEW** All engines, Hastings, with anti-drain back feature, oil light goes out immediately upon start up . . . . . C1AZ-6731-H 8.95



**Regularly replacing your oil filter is a smart way to keep your classic car running smoothly for years to come.**

## Show Oil Filters

Need an edge to win the trophy? One of these concours quality oil filters could put you over the top! Get yours today!



- 61-65 Oil filter, red with white lettering, to May 1965, all engines . . . . . R1A-RED 35.95
- 65-66 Oil filter, gold "6,000 Mile" with black lettering, from May 1965, all engines . . . . . FL1-GOLD 35.95

## Air Filters

Any engine will run better if it "breathes" better. A quick & easy way to improve the breathing ability of your engine is to replace the air filter. The quick fix for many is to use compressed air to blow the dirt out of the filter. Experts agree that in many cases this only imbeds the dirt deeper into the filter. Call us now—we'll get an air filter out to you as soon as you hang up the phone. Your engine will be happy you did.



- 58-60 352 Hastings, 9-3/4" OD x 7-1/2" ID x 2-1/4" high . . . . . C3VY-9601-H 7.95
- 59-60 430 Hastings, 9-3/4" OD x 7-1/2" ID x 2-1/4" high. . . . . C3VY-9601-H 7.95
- 61-63 390 4 bbl, Hastings . . . . . C1VE-9601-H 10.95
- 62-63 390 3x2 bbl "M" code, **Motorcraft** . . . . . EDJ-9601-M 25.95
- 1964 390 Hastings . . . . . C3AZ-9601-H 11.95
- 65-66 390 & 428, **Motorcraft** . . . . . C5ZZ-9601-M 9.95

## Fuel Filters

Don't see a fuel filter listed for your car? Our in-line fuel filter fits every car. Just plumb it into your fuel line & protect your carb from dirt & other contaminants.

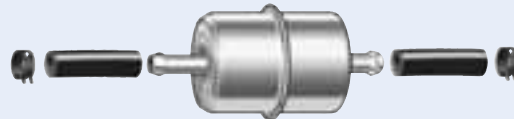

- ALL In-line type, includes hoses & clamps, Hastings . . . . . C2RZ-9155-H 6.95

Dirt in your fuel lines is a problem, if that dirt gets to your carburetor, it's a major problem. Once dirt gets into your carb, you might have no other choice but to rebuild it & that takes time & can be costly. Save yourself the trouble & expense, install a new fuel filter today.



- 59-60 Fuel filter, 430 Hastings . . . . . CODF-9155-H 6.95
- 62-66 Fuel filter element, all engines with canister type fuel pumps, **Motorcraft** . . . . . C4AZ-9365-M 6.95

## In-Line Fuel Filter Parts

- 58-59 Filter element, for in-line glass bowl fuel filter, includes rubber gasket . . . . . B7S-9365-B 9.95



- 58-59 Bracket & clip, 352 with in-line fuel filter. . . . . B5S-9180-A 7.95
- 58-59 Clip, for 352 with in-line fuel filter . . . . . B5TZ-9B281-A 2.95





Back-up Light Switch

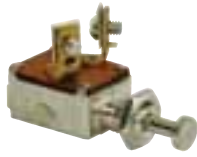

58-60 For manual or overdrive transmission . . . . . 51A-15520-A 8.95

Extension or Overdrive Housing Bushings & Seals



58-59 Overdrive housing bushing . . . . . B5AZ-7A034-A 5.95
58-60 Extension housing bushing, manual transmission . . . . . B5AZ-7A034-A 5.95
58-59 Extension seal, manual transmission, 2.72"-2.78" OD . . . . . C3AZ-7052-A 9.95
58-60 Overdrive seal, 2.72"-2.78" OD . . . . . C3AZ-7052-A 9.95

Overdrive Cable Assembly



58-60 Includes 80" long cable, nut hardware, chrome die-cast handle, aluminum end sleeve, crimping tool & cable shortening instructions . . . . . A9AZ-7A650-A 49.95

Overdrive Relay Wiring

1958 To ignition coil wire, 54" long . . . . . FEV-14381-A 6.95
1958 To ignition switch wire, 30" long . . . . . FEV-14396-A 4.95

Transmission Gasket Set

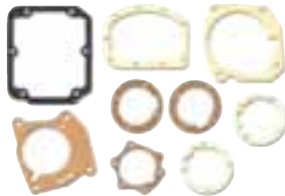

58-60 8 pieces, 3-speed manual or overdrive . . . . . B6A-7153-D 16.95 set

Clutch Fork Boot



58-60 Leather . . . . . AB-7513-B 30.95

Clutch Fork Anti-Rattle Spring



58-60 NEW Clutch fork anti-rattle spring . . . . . C6AZ-7562-AR 3.95

Clutch Release Lever

Shaft Bushing (2 pair required)



58-60 Bronze split bushing . . . . . 01A-7517 4.25 pair

Clutch Pressure Plate & Clutch Disc



58-60 Clutch pressure plate, 11", new, not remanufactured . . . . . B8A-7563-B 110.95
58-60 Clutch disc, 11", new, not remanufactured . . . . . B8A-7550-G 42.95



58-60 NEW Clutch alignment tool, 23 spline . . . . . F7550B 7.95

Throwout Bearing & Bearing Hub



58-60 Throwout bearing . . . . . 8A-7580-A 19.95
58-60 Throwout bearing & hub set . . . . . B7A-7561-ST 36.95 set

Clutch Pilot Bushing



58-60 Bronze . . . . . B8A-7600-A 7.95

It's cheap insurance to replace the pilot bushing when you are doing a clutch job. Remember, chances are, it's been in there for over 40 years—replace it today—you won't regret it!

Shift Levers

1958 Shift lever . . . . . B8S-7210 40.95
1959 Shift lever . . . . . B9S-7210 40.95



1960 Shift lever (shown) . . . . . COSB-7210 40.95
61-63 Shift lever, includes insulator . . . . . C1SZ-7210-A 40.95



64-66 Shift lever, includes insulator . . . . . C4SZ-7210-A 40.95

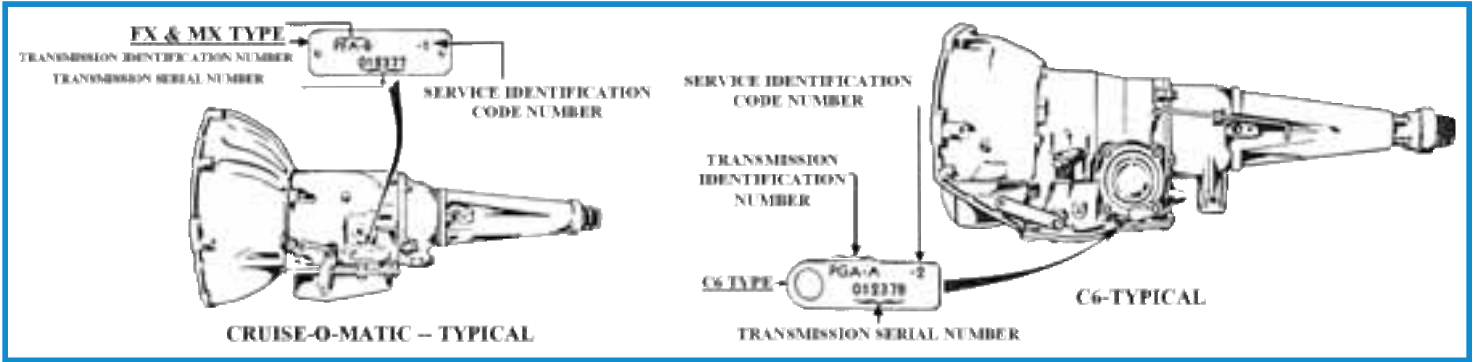

## Shift Lever Parts

- 58-60 Shift collar, the piece on the steering column that the shift lever fits into . B8S-7228-A 119.95
- 58-64 Shift lever insulator, rubber, automatic transmission . . . . . B8S-7246-AR 3.95



*A common problem on '64 thru '66 Birds is a "sloppy" shifter. The cure is our shift lever detent kit. Install it & you should see a world of difference-no more holding the shifter in reverse, no more guessing where neutral is. Buy the kit & save money!*



- 64-66 Shift lever detent kit, includes detent plate, upper bearing sleeve, upper steering column bearing, lower gear shift tube bushing & the lower column tapered cone . . . . C4SZ-7A216-KT 66.95 kit



- 61-66 Steering column upper bearing, part of kit C4SZ-7A216-KT, **Genuine Ford** . . C5SZ-3517-A 18.95
- 61-66 Steering column upper bearing sleeve, part of kit C4SZ-7A216-KT . . . . C5SZ-3518-AR 9.95



- 63-66 Steering column lower tapered cone, part of kit C4SZ-7A216-KT . . . . C3SZ-3C773-B 15.95
- 64-66 Gear shift lever detent plate, part of kit C4SZ-7A216-KT . . . . C4SZ-7A216-A 15.95
- 64-66 Steering column lower gear shift tube bushing, part of kit C4SZ-7A216-KT . . . . C4SZ-7347-AR 11.95
- 58-60 Nut at the top of the steering column, **Genuine Ford** . . . . . 33947-S2 5.95

## Shift Selector Dial



- 64-66 "P R N DRIVE L" . . . . . C4SZ-7A213-C 24.95

## Neutral Safety Switches

- 58-60 With or without backup lights . . . . . B8S-7A217-A 43.95
- 61-63 With or without backup lights . . . . C1SF-7A217-A 48.95
- 1964 . . . . . C4SZ-7A247-A 64.95

## Transmission Dipsticks



- 58-59 Before 6-15-59 (shown) . . . . . B5AZ-7A020-A 27.95
- 1961 Cruise-O-Matic . . . . . C1SS-7A020-B 27.95
- 1962 Cruise-O-Matic, before 2-22-62 . . . C2SZ-7A020-A 27.95
- 62-65 Cruise-O-Matic, from 2-22-62 . . . . C2SZ-7A020-B 27.95
- 66-68 Cruise-O-Matic . . . . . C6AZ-7A020-C 27.95
- 66-68 C6 . . . . . C6AZ-7A020-A 27.95

## Extension Housing Bushing



- 60-66 Cruise-O-Matic or C6 . . . . . B5AZ-7A034-A 5.95

## Extension Housing Seal



- 60-66 All automatic transmissions. . . . . C3AZ-7052-A 9.95

## Extension Housing Gasket



- 1966 C6 . . . . . C6AZ-7086-A 1.95

## Screen & Pan Gasket Kits



- 58-66 Cruise-O-Matic, . . . . . B9MP-7A098-KT 14.95 kit
- 1966 C6 . . . . . C6AZ-7A098-KT 10.95 kit





## Pan Gaskets



58-66	Cruise-O-Matic, <b>except</b> 430	.....	.B5SZ-7A191-A	3.95
59-60	Cruise-O-Matic, 430 only	.....	.B8SZ-7A191-A	6.95
1966	C6	.....	.C6AZ-7A191-B	7.95

## Shift Modulator Valves & Hose



61-66	Valve, Cruise-O-Matic	.....	.C1AZ-7A377-B	15.95
1966	Valve C6	.....	.C4AZ-7A377-B	15.95

## Manual Control Lever Oil Seal



58-66	Cruise-O-Matic or C6	.....	.C7AZ-7B498-A	3.95
-------	----------------------	-------	---------------	------

## Transmission Kick Down Rod Return Spring & Bracket



61-66	Spring	.....	.C2SZ-7B146-B	4.95
61-66	Bracket, mounts on a carb stud	.....	.C1SZ-9741-A	9.95

## Converter Housing Inspection Plates & Gasket

58-62	Inspection plate, with Cruise-O-Matic transmission	.....	.B8S-7986	22.95
63-66	Inspection plate, with Cruise-O-Matic transmission	.....	.C3SZ-7986-A	22.95
1966	Inspection plate, with C6 transmission	.....	.C6AZ-7986-A	31.95
58-66	Gasket for lower bell housing inspection plate (2 required)	.....	.C3AZ-7989-A	2.95

## Transmission Mounts



58-60	<b>Except</b> 430 V-8	.....	.B8S-6068-A	23.95
61-63		.....	.C2SZ-6068-AR	24.95
64-65		.....	.C3AZ-6068-C	14.95
1966	With Cruise-O-Matic	.....	.C3AZ-6068-C	18.95
1966	With C6	.....	.C6SZ-6068-D	14.95



The cooling system is one of the hardest working systems on any vehicle. When you think about the constant heat & pressure of coolant flowing thru hot water jackets, rubber hoses, the water pump itself & the radiator, it's easy to understand how leaks & other failures are so common.

Yet when it's working properly, our cooling system is often "out of sight & out of mind." Keep a close eye on the many components of the cooling system on your car & keep your friendly & reliable Ford engine cool & happy!

## Water Temperature Sending Units

Your little water temperature sending unit has the vital job of keeping you informed of how things are going inside the critical water jackets of your engine & is your best tool for avoiding a dangerous overheat condition. Be sure that corrosion & age don't keep your sending unit from functioning properly & make sure that all wiring is properly connected & in good condition. Replace that old unit with a fresh new one, for reliability & general peace of mind.



58-61		.....	.B7A-10884-A	9.95
62-63	Before 11-15-62	.....	.B7A-10884-A	9.95
63-64	From 11-15-62, requires adapter (currently unavailable)	.....	.C3AZ-10884-B	12.95
65-66	Before 9-1-65	.....	.C3AZ-10884-B	12.95
1966	From 9-1-65	.....	.C6DZ-10884-B	14.95

## Expansion Tanks

New expansion tanks are now available! No more trying to weld the seam leaks, no more hoping the used one you have lasts the "season." Call & order yours today!

58-60	<b>Except</b> 430	.....	.B8SZ-8A080-A	209.95
-------	-------------------	-------	---------------	--------



61-65	The filler neck is on the right (passenger's) side	.....	.C1AZ-8A080-A	199.95
65-66	The filler neck is on the left (driver's) side	.....	.C6MY-8A080-A	199.95





## Radiator Petcock



58-66 Radiator petcock . . . . . 8A-8115 3.80

## Radiator Air Baffle & Staples



62-63 Baffle, mounts on radiator support . . C2SZ-8B093-A 8.95  
 62-63 Staples, 16 pieces . . . . . 2HK28N 1.95 kit

## Radiator Caps



58-66 13 lbs., **Motorcraft** replacement type . . . . . E5TZ-8100-A 8.95

*Add that "original" look to your car with one of our reproduction radiator caps. The standard cap was zinc plated, while the chrome cap was used with the engine dress-up package.*



58-66 14 lbs., zinc plate, reproduction of original S. M. Co. cap . . . . . RC-14-ZS 24.95  
 62-66 14 lbs., chrome plate, reproduction of original S. M. Co. cap . . . . . RC-14-CS 24.95

## Fan Shrouds



61-65 2-piece metal, as original . . . . . C4SZ-8147-B 99.95  
*The fan shrouds listed below are 1-piece fiberglass replacements.*



1966 17" high core . . . . . C6SZ-8146-A 136.95  
 1966 19" high core (shown) . . . . . C6SZ-8146-B 136.95

## Water Wetter

*Is your engine running hot? Cool it off with Water Wetter®. Adding one 12 oz. bottle to 12-16 quarts of coolant can drop the operating temperature up to 30°. Not only that, you will also be reducing rust, corrosion & electrolysis in your cooling system. It's modern science for your classic car. Call us & place your order today!*



ALL **NEW** Water Wetter®, 12 oz. bottle . . . . . WET-H2O 9.95

## Script Radiator Hoses

*Why put up with ugly "accordion" style generic hoses? We have upper & lower radiator hoses formed in the correct shape with the correct ink-stamped factory engineering numbers & logo as original.*

### Single Hoses

58-60 Upper, with original script, 352 only . . B8S-8260-A 19.95  
 59-60 Upper, with original script, 430 only . . B8S-8260-B 19.95  
 61-63 Upper, with original script . . . . . C1SS-8260-C 19.95  
 64-65 Upper, with original script . . . . . C4SE-8260-A 19.95  
 1966 Upper, with original script . . . . . C6SE-8260-A 19.95  
 58-60 Lower, with original script, 352 only . . B8S-8286-A 19.95  
 59-60 Lower, with original script, 430 only . . B8S-8286-B 19.95  
 61-63 Lower, with original script . . . . . C1SS-8286-B 19.95  
 64-65 Lower, with original script . . . . . C4SE-8286-A 19.95  
 1966 Lower, with original script . . . . . C6SE-8286-A 19.95

### Hose Sets



**SAVE MONEY WHEN YOU BUY THE SET!**

61-63 Script radiator hose set . . . . . 8260-54 57.95 set  
 64-65 Script radiator hose set . . . . . 8260-55 57.95 set  
 1966 Script radiator hose set, 390 & 428 . . . . . 8260-56 57.95 set

## Replacement Type Radiator Hoses



58-60 Upper, 352 . . . . . 8260-24533 12.95  
 61-63 Upper . . . . . 8260-24563 14.95  
 64-66 Upper . . . . . 8260-24593 14.95  
 58-60 Lower, 352 . . . . . 8286-24749 19.95  
 61-66 Lower, 390 & 428 cut to fit . . . . . 8286-24769 14.95



## Radiator Hose Clamps

Original Band Type (2 required)

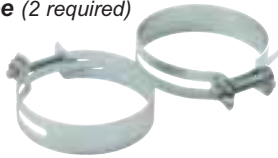

58-60 2" . . . . .	B8261	1.00
58-60 1-3/4" . . . . .	B8287	1.00

Tower Type (as required)



61-66 #34, 15/16" to 1-1/16" . . . . .	HT34	1.95
61-66 #56, 1-9/16" to 1-3/4" . . . . .	HT56	1.95
61-66 #62, 1-3/4" to 1-15/16" (not shown) . . . . .	HT62	1.95
61-66 #70, 1-31/32" to 2-3/16" . . . . .	HT70	1.95
61-66 #80, 2-9/32" to 2-1/2" . . . . .	HT80	1.95

The following hose clamps are exact reproductions of the original "tower type" made by the Wittek company. They feature the original company name "Wittek" & the size stamped into them.

61-66  Set, includes all 4 radiator hose clamps . . . . .	C1SZ-8287-RST	6.95 set
-----------------------------------------------------------	---------------	----------



**BUY a SET & SAVE**

62-66  Set, includes all 4 radiator & all 12 heater hose clamps . . . . .	C2SZ-8287-ST	24.95 set
62-66  Set, includes all 12 heater hose clamps . . . . .	C2SZ-8287-HST	18.95 set



Water circulating throughout your engine is critical to its longevity. Don't take a chance on an "iffy" water pump, choose from our complete selection of new or remanufactured pumps & get that water moving to keep your engine cool! All of the water pumps listed below include the mounting gaskets.

## New Water Pumps

61-64 390, mounting gaskets included . . . . .	C4AZ-8501-B	90.95
65-66 390 & 428, mounting gaskets included . . . . .	DOAZ-8501-A	79.95

## Remanufactured Water Pumps

Our remanufactured water pumps are sold on an exchange basis. A core fee of \$20.00 will be charged if your core is not received by the shipping date. The core fee will be refunded if an acceptable core is received within 90 days of purchase date in the rebuilder's original package. All water pumps include the necessary mounting gaskets.



58-60 352 . . . . .	B9AZ-8501-AR	79.95
61-64 390, use with generator . . . . .	C4AZ-8501-BR	49.95
65-66 390 & 428, use with alternator . . . . .	C5AZ-8501-VR	39.95

## Water Outlet Cap



58-60 <b>Genuine Ford</b> . . . . .	C4TZ-8A500-A	2.95
-------------------------------------	--------------	------

## Water Pump to Block Gaskets (2 required)



58-66 352, 390 & 428 engines . . . . .	B8A-8507-A	1.95
59-60 430 . . . . .	B8E-8507-A	1.95

## Water Pump Pulley



1966 Double groove, 5-7/8" OD, original stamping number C6AE-A, 390 & 428 with air & without Thermactor (smog) pump . . . . .	C6AZ-8509-A	54.95
-------------------------------------------------------------------------------------------------------------------------------	-------------	-------

## Water Pump Pulley Spacer



61-63 Aluminum, 390, without A/C . . . . .	B5S-8546-A	15.95
--------------------------------------------	------------	-------

## Water Bypass Tube



58-66 Steel, 5/8" OD, 2-1/2" long, . . . . .	C5AZ-8555-A	6.95
----------------------------------------------	-------------	------

## Water Bypass Hose & Clamp

61-66 Water bypass hose, 2-3/4" x 9/16" x 1", 8 cylinder 352, 390 & 428, <b>Motorcraft</b> . . . . .	C2OZ-8597-D	2.95	
60-66 Water bypass hose clamp (2 required) . . . . .	COAZ-18572	0.95	

## Thermostats

58-66 160° . . . . .	C2AZ-8575-B	5.95	
58-66 180° . . . . .	C2AZ-8575-A	5.95	
58-66 195° . . . . .	C2AZ-8575-C	5.95	

## Thermostat Gaskets

58-66 352, 390 & 428 . . . . .	B8A-8255-A	1.95
59-60 430 . . . . .	C1VE-8255-A	2.95

## Mega Copper Sealant

The solution to those times when a gasket just doesn't seal our gasket in a tube! This is the same type as used in many places on most new cars built today. It replaces cork, rubber or any other type of cut gasket to form a leak-proof seal. Order some today—you'll love the "sealed for good" results. Exceeds O.E.M. standards, resists oil, water, antifreeze mixture, grease & transmission fluid, use it on water pumps, exhaust manifolds, valve covers, timing gear covers, transmission pans, water neck outlets or any place a high performance gasket is needed.



ALL Mega copper sealant, 3 oz. tube . . . . .	A5251SEAL	4.95
-----------------------------------------------	-----------	------

# COOLING SYSTEM



## Replacement Fan Blade



61-66 390 engine, 6 blades, will not work with fan clutch, clutch-type fan blades are not currently available. . . . .8600-C 63.95

## O.E.M. Type Thermal Fan Clutch



61-63 **NEW** Special short shaft for cars with A/C, this one fits! . . . . . C1SB-8A616 73.95  
 64-66 390 & 428, **Motorcraft** . . . . . EOMY-8A616-A 80.95

# FAN BELTS

A common fan belt problem occurs when belts jump off of pulleys, especially under hard acceleration. Belts are often ruined this way, being torn or stretched out of shape. Remember that all pulleys must be aligned exactly with each other.

Your belt should look like a perfectly straight line, when you stand back & sight down the front edge of the belt from one pulley to another. If you

notice a slight bend or change of direction in the belt where it passes into the groove of a pulley, it will probably jump off under high RPM's. Align those pulleys as perfectly as possible. You might need to replace a bracket, or use shims on mounting bolts. Whatever it takes, get those pulleys lined up correctly & your fan belts will live longer. Your Ford car will thank you.

**Our low cost belts are perfect for the daily driver. The quantity required is one, unless otherwise stated.**

**1958 352**  
 FAN & GENERATOR, without A/C . . . . . 8620-18779 11.95  
 FAN & GENERATOR, with A/C . . . . . 8620-18773 11.95  
 POWER STEERING, without A/C . . . . . 8620-18619 11.95  
 A/C COMPRESSOR, Selectaire: identified by "Selectaire" nameplate on A/C controls . 8620-18779 11.95  
 A/C COMPRESSOR, "Polar Aire". . . . . 8620-18883 11.95

**1959 352**  
 FAN & GENERATOR, without A/C . . . . . 8620-18779 11.95  
 FAN & GENERATOR, with A/C . . . . . 8620-18769 11.95  
 POWER STEERING, without A/C . . . . . 8620-18619 11.95  
 POWER STEERING, with A/C . . . . . 8620-18619 11.95  
 A/C COMPRESSOR . . . . . 8620-18883 11.95

**For 1959 430 Engine**  
 FAN & GENERATOR, without A/C . . . . . 8620-18779 11.95  
 POWER STEERING, without A/C . . . . . 8620-10619 11.95

**For 1960 352 Engine**  
 FAN & GENERATOR, with A/C . . . . . 8620-18769 11.95  
 POWER STEERING, with A/C . . . . . 8620-10604 11.95  
 POWER STEERING, without A/C . . . . . 8620-18629 11.95  
 A/C COMPRESSOR . . . . . 8620-10775 11.95

**For 1960 430 Engine**  
 FAN & GENERATOR, without A/C (2 required) . . . . . 8620-18773 11.95  
 FAN & GENERATOR, with A/C (2 required). . 8620-18763 11.95  
 POWER STEERING, with or without A/C . . . 8620-18624 11.95  
 A/C COMPRESSOR . . . . . 8620-10779 11.95

**For 1961 390 Engine**  
 FAN & GENERATOR, without A/C . . . . . 8620-18779 11.95  
 FAN & GENERATOR, with A/C (2 required). . 8620-18753 11.95  
 POWER STEERING, without A/C . . . . . 8620-10758 12.95  
 POWER STEERING, with A/C . . . . . 8620-10619 11.95  
 A/C COMPRESSOR . . . . . 8620-10748 11.95

**1962 390**  
 FAN & GENERATOR, without A/C . . . . . 8620-18783 11.95  
 FAN & GENERATOR, with A/C (2 required). . 8620-18763 11.95  
 POWER STEERING, without A/C . . . . . 8620-10758 12.95  
 POWER STEERING, with A/C . . . . . 8620-10619 11.95  
 A/C COMPRESSOR . . . . . 8620-10748 11.95

**1963 390**  
 POWER STEERING, with A/C . . . . . 8620-10619 11.95  
 POWER STEERING, without A/C . . . . . 8620-10758 12.95  
 FAN & ALTERNATOR, with A/C (2 required). . 8620-18739 11.95  
 FAN & ALTERNATOR, without A/C . . . . . 8620-18763 11.95  
 A/C COMPRESSOR . . . . . 8620-10748 11.95

**1964 390**  
 POWER STEERING, without A/C . . . . . 8620-10758 12.95  
 FAN & ALTERNATOR, without A/C . . . . . 8620-18763 11.95  
 FAN & ALTERNATOR, with A/C . . . . . 8620-18763 11.95  
 POWER STEERING, with A/C . . . . . 8620-18834 12.95  
 A/C IDLER . . . . . 8620-10814 14.95  
 FAN & ALTERNATOR, with A/C . . . . . 8620-18763 11.95

**1965 390**  
 FAN & ALTERNATOR, with A/C . . . . . 8620-18763 11.95  
 FAN & ALTERNATOR . . . . . 8620-18783 11.95  
 POWER STEERING Ford pump, without A/C . 8620-10784 11.95  
 POWER STEERING Ford pump, with A/C . . 8620-18875 11.95  
 POWER STEERING Eaton pump, without A/C . . . . . 8620-10758 12.95  
 A/C IDLER . . . . . 8620-10934 14.95

**1966 390 & 428**  
 FAN & ALTERNATOR, without smog (air) pump, without A/C . . . . . 8620-18783 11.95  
 FAN & ALTERNATOR, without smog (air) pump, with A/C . . . . . 8620-18763 11.95  
 FAN & ALTERNATOR, with smog (air) pump, without A/C . . . . . 8620-18753 11.95  
 FAN & ALTERNATOR, with smog (air) pump, with A/C . . . . . 8620-18753 11.95  
 POWER STEERING, without smog (air) pump, without A/C . . . . . 8620-18694 11.95  
 POWER STEERING, with or without smog (air) pump, with A/C . . . . . 8620-18875 11.95  
 POWER STEERING, with smog (air) pump, without A/C . . . . . 8620-10779 11.95  
 A/C IDLER . . . . . 8620-10934 14.95  
 AIR PUMP, with A/C . . . . . 8620-10904 16.95

## Fan Belt Dressing



ALL Belt dressing, adds to belt life & helps increase performance, 5 oz. spray can . . . . .RSP10 \* 3.95

\* **HAZARDOUS MATERIAL** can only be shipped by ground/surface within the U.S. because of government regulations.





No one wants to be stranded on the side of the road because of a rusting, leaky fuel tank. Replace your problematic tank with a quality stamped steel gas tank from MAC's. You'll have the peace of mind knowing that your new tank will be trouble-free for years to come. When installing your new gas tank, be sure to replace the sending unit "O" ring

seal (on the following page). Or if you don't want a new tank for your car, try our Gas Tank Sealer (RSP22A). MAC's has been selling this product for years & our customers tell us how great it works. Known for its complete coverage, one can will do the trick, call & order yours today!

## Gas Tanks



**The quality of used gas tanks can vary widely. Don't worry about what you're getting anymore; we now have brand new gas tanks available.**

Constructed of Ni-terne steel for excellent corrosion resistance & long life. All of our tanks have a built-in drain plug. They all include the lock ring & the rubber "O" ring for the sending unit. These new tanks are reasonably priced & ready to ship-call today!

**OS** All gas tanks are over-sized & require additional shipping charges.



58-60 ..... B9S-9002-A 229.95  
1961 ..... C1SZ-9002-A 229.95



62-63 ..... C2SZ-9002-A 229.95  
64-66 Includes the filler neck "O" ring ..... C4SZ-9002-B 229.95



**CAUTION:** Gasoline vapors are extremely flammable! Removal of a gas tank involves serious risk of fire or explosion. **NEVER** use a regular incandescent light around gas tanks, as cold liquid gas might burst a hot glass bulb if splashed, resulting in explosion. If you are not certain about how to safely remove your gas tank, take your new gas tank to a professional for installation.

## Gas Tank Straps

58-60 Straps ..... B8S-9092-PR 44.95 pair  
61-63 Straps ..... C1SZ-9092-PR 38.95 pair  
64-66 Straps ..... C4SZ-9092-PR 38.95 pair

## Hardware Kits



58-60 Includes bolts & nuts ..... B8S-9A010-KT 15.95 kit  
61-63 Includes bolts & nuts ..... C1SZ-9A010-KT 23.95 kit  
64-66 Includes bolts & nuts ..... C4SZ-9A010-KT 14.95 kit

## Gas Tank Neck Grommet, "O" Ring & Seal



58-60 Neck to quarter panel grommet ..... B8SZ-9080-A 9.95  
61-66 "O" ring (shown) ..... C1VY-9072-A 1.95  
64-66 Filler neck to body seal (shown) ..... C4SZ-9076-B 5.95

## Gas Tank Gauge Sending Units

Always running on empty? If you're having fuel gauge problems, the first thing to look at is the sending unit. MAC's carries a terrific supply of reproduction gas gauge sending units that work with the original electrical systems. Just drop it in & you're good to go! Get yours today!



58-60 Includes "O" ring ..... B7A-9275-FR 67.95  
61-63 Includes "O" ring ..... C3SZ-9275-A 74.95



64-66 Includes "O" ring, without "low fuel" warning system ..... C4SZ-9275-C 88.95  
64-66 Includes "O" ring, with "low fuel" warning system ..... C4SZ-9275-D 120.95

## Gas Tank Sealer

Put a stop to rust, leaks & corrosion permanently. Resistant to all fuels including phase II oxygenated fuels & alcohol. With its ability to bond to metal or fiberglass it can be used in a multitude of applications. Our 1-quart can is enough to treat several tanks.



ALL Gas tank sealer, 1 quart ..... RSP22A \* 23.75 quart

## Fuel Stabilizer

The ideal formulation to add to the gas tank when storing vehicles for extended periods. It not only prevents varnish & tank corrosion, it has a no alcohol formula & will not attack rubber lines or diaphragms as many other fuel stabilizers do.

ALL 1 quart can, 1 oz. of this product will keep 3 gallons of fuel fresh for at least 3 years ..... RSP101 \* 28.95 quart



\* **HAZARDOUS MATERIAL** can only be shipped by ground/surface within the U.S. because of government regulations.



That lock ring or "O" ring seal has probably been on your gas tank for forty plus years. They can be brutal to remove & many times resemble a pretzel when you finally get them out. Plan ahead, if you are replacing the sending unit, order a lock ring at the same time.

## Gas Tank Sending Unit "O" Rings & Lock Rings

58-60 "O" ring	B9AF-9276-A	2.95	
61-66 "O" ring	COAF-9276-A	1.95	
58-60 Lock ring	B7A-9277-A	9.95	
61-66 Lock ring	COAZ-9A307-B	6.95	



One of the most common causes of an ineffective dash fuel gauge is simply a defective float. Over time they develop holes where they are soldered together & fill up with gas. Put a MAC's replacement on the arm of your sending unit & your gas gauge will work again!

## Gas Tank Sending Unit Floats

Brass, just like the original!

58-66 Snaps onto arm	COAZ-9202-B	4.95	
58-66 Special solid design by Stewart-Warner	COAZ-9202-SW	11.95	

## Gas Tank Sending Unit Filters

62-66 3/8" ID, <b>Genuine Ford</b>	D1AZ-9A011-A	22.95	
62-66 3/8" ID, reproduction	D1AZ-9A011-AR	13.95	

## Gas Caps

58-60 Cadmium finish (shown)	B9A-9030-C	7.95	
61-66 Gas cap	C5AZ-9030-A	7.95	

## Gas Tank Filler Door Bumpers

58-60 Gas tank filler door bumpers, rubber	BA-13398-PR	4.95 pair	
61-63 Gas tank filler door bumper (not shown)	.375837	2.95	
1964 Gas tank filler door bumpers, rubber	.375838-S	3.95 pair	

## New Fuel Pumps

For reliable performance, put a brand new high quality fuel pump on your Bird. Old fuel pumps often work great ... right up until the moment that they fail from age, wear & deterioration. One day you're happily driving along & then the engine dies. You're not out of gas, yet none is getting to the carburetor. Yep, the ol' fuel pump has bitten the dust. Don't wait, put a brand new fuel pump on your car today!

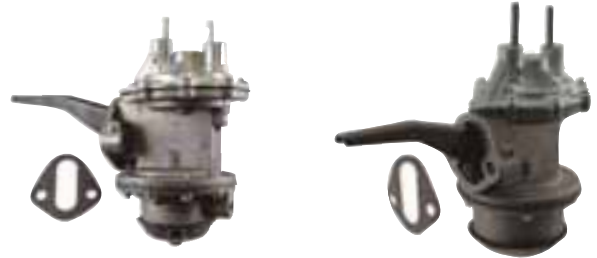

1958	352, dual action with vacuum wipers, mounting gasket is included	B8A-9350-D	75.95
1960	352, dual action with vacuum wipers, mounting gasket is included	C1SE-9350-A	87.95



1961	390, single action, mounting gasket is included	B5SZ-9350-C	65.95
62-64	390, canister type, mounting gasket is included	C3SZ-9350-C	39.95



65-66	390 & 428, canister type, mounting gasket is included	C3SZ-9350-F	33.95
58-59	Gasket, for glass bowl on original fuel pump	A9173	0.35

## Fuel Pump Filter Canister & Parts



62-66	Red with white "FoMoCo" logo	C3AZ-9355-R	15.95
62-66	Plain steel finish, includes seal	C3AZ-9355-A	15.95
62-66	Filter, for above canister, includes rubber seal, <b>Motorcraft</b>	C4AZ-9365-M	6.95
62-66	Seal, for fuel pump filter canister, rubber	C2AZ-9364-A	2.95



Fuel Pump to Carburetor Fuel Lines

Table with 4 columns: Year, Description, Part Number, Price. Rows include 58-60 352, 1961 2 pieces, 390, 62-63 390 with 4 bbl carburetor, etc.

Fuel Pump Mounting Gasket & Glass Bowl Gasket



Table with 4 columns: Year, Description, Part Number, Price. Rows include 58-66 352, 390, 428 & 430, 58-62.

Flexible Fuel Lines



Table with 4 columns: Year, Description, Part Number, Price. Rows include 1958 Main line to pump, 59-63 Main line to pump, except 430.

Fuel Line Fitting Sealer



Table with 4 columns: Year, Description, Part Number, Price. Row: ALL Put this non-hardening sealer directly on threads to prevent leaks, 4 oz. can. . . .RSP25 \* 5.45

Fuel Log Assembly



Table with 4 columns: Year, Description, Part Number, Price. Row: 62-63 "M" series engine with 3x2 bbl carburetors . . . . . C1AE-9D280-A 56.95

In-Line Fuel Filter Parts



Table with 4 columns: Year, Description, Part Number, Price. Rows include 58-59 Filter element, for in-line glass bowl fuel filter, includes rubber gasket . . B7S-9365-B 9.95, 58-59 Fuel filter bracket, 352, includes clip . . B5S-9180-A 7.95, 58-59 Clip, 352 with in-line fuel filter (not shown) . . . . . B5TZ-9B281-A 2.95

Fuel Pump Vacuum Lines

Table with 4 columns: Year, Description, Part Number, Price. Rows include 58-59 Fuel pump to manifold, plain steel, 352 . . . . . B8A-9413-M 12.95, 58-59 Fuel pump to manifold, stainless steel, 352 . . . . . B8A-9413-MSS 16.95, 58-59 Fuel pump to wiper motor, plain steel . . . . . B8S-9413-W 16.95, 58-59 Fuel pump to wiper motor, stainless steel . . . . . B8S-9413-WSS 21.95

\* HAZARDOUS MATERIAL can only be shipped by ground/ surface within the U.S. because of government regulations.

Remanufactured Carburetors

Remanufactured carburetors are sold on an exchange basis. If we do not have your rebuildable core before we ship you will be charged the core fee listed. This core fee will be refunded if an acceptable core is received within 90 days of your purchase date. Your core must be returned in the box you received it in.



Table with 4 columns: Year, Description, Part Number, Price. Rows include 58-65 390 with a Ford 4 bbl, Autolite 4100 with a 1.12 venturi, \$200.00 core fee . . . . . 9510-4100-112 451.95, 1966 390 & 428 with a Ford 4 bbl, Autolite 4100 with a 1.08 venturi, \$300.00 core fee . . . . . 9510-4100-108 451.95

Dash Pots & Bracket



Table with 4 columns: Year, Description, Part Number, Price. Rows include 58-64 NEW Dash pot, early style metal & plastic case . . . . . B8A-9B549 35.95, 64-66 NEW Dash pot, original style metal case. . . . . C5AZ-9B549 35.95, 58-66 Dash pot bracket (not shown) . . . . B8AZ-9B550-B 11.95

Carburetor Tune-Up Kit

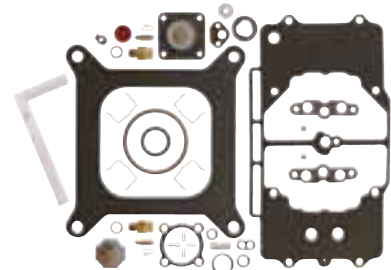

Table with 4 columns: Year, Description, Part Number, Price. Row: 58-66 352 or 390 with a Ford 4 bbl, does not include secondary diaphragm (listed below) or return spring . . . . . C2SZ-9A586-D 23.95 kit

Carburetor Secondary Diaphragms

Since the 4100 series 4 bbl carburetors are now close to 50 years old, it stands to reason that most have been rebuilt. Sometimes the rebuilder might have used what they had available, correct or not. The "early" style has a steel secondary diaphragm actuator arm & the "late" style has a plastic arm. The "early" style is no longer available, but you can use the "late" style as long as you replace the steel actuator arm with a plastic one. Please take a look at the actuator arm so you know exactly what you need before placing your order.

Table with 4 columns: Year, Description, Part Number, Price. Rows include 58-66 Late style, uses a plastic actuator arm . . . . . B8AZ-9503-LATE 16.95, ALL Plastic actuator arm, this is a replacement for the early style steel arm that is no longer available. . . . . C5AZ-9853-A 4.95

Carburetor Accelerator Pump Diaphragm

Table with 4 columns: Year, Description, Part Number, Price. Row: 65-66 Ford 4 bb, 390, Motorcraft. . . . . C4AZ-9B559-A 23.95





## Fast Idle Cam Levers

These levers were made in two styles. Applications were not consistent. You might have either one on any given car.



- 58-66 Straight type, **Motorcraft** . . . . . C4AZ-9F577-B 16.95
- 58-66 Dogleg type . . . . . C3AZ-9F577-A 16.95

## Needle & Seat

This new design needle & seat will cure the many ills of a conventional needle & seat. It helps to eliminate "flood over," dirt & rust sticking to the needle & gives a more consistent fuel level. All this adds up to better fuel economy & as an added bonus, it will outlast any currently available needle & seat. It is precision made & the inverted flare seat provides positive sealing & improved fuel control. The needle contains a high quality "fluorocarbon" alcohol resistant rubber disc that rotates in the end of the needle, thus insuring a positive seal every time. Install one in your carb & you'll reap the benefits from day one. Call us today!



- 58-66 **NEW** Needle & seat, for Ford Autolite "4100" series 4 bbl carbs . . . . . B7A-9564 5.95

## Carburetor Spacers & Spacer Plate Gaskets



- 58-60 Carburetor spacer, 352 (shown) . . . B8SZ-9A589-A 44.95
- 1966 Carburetor spacer, 390 & 428 . . . C6SZ-9A589-A 44.95

- 62-63 Spacer plate gasket, upper & lower, for 3x2 bbl carb "M" code engines (3 required) . . . . . C2AZ-9447-F 2.95

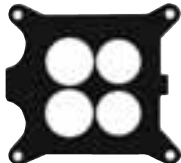

- 58-66 Spacer plate gasket, upper & lower, 352 & 390 with 4 bbl carburetor (2 required) (shown) . . . . . C8SZ-9447-A 1.95
- 62-66 Spacer plate gasket, lower . . . . . C2AZ-9447-G 2.95

## Carburetor Fitting

- 1960 Used to adapt screw-in fuel filter to carburetor, 430 . . . . . COAE-9A520-A 13.95

## Carburetor Top Gasket to Air Cleaner

- 65-66 Gasket, carb top to air cleaner . . . . C5ZZ-9654-B 3.95

## Throttle Stops & Bumper



- 61-64 Throttle stop . . . . . C1SZ-9A853-A 16.95
- 1966 Throttle stop, C6 transmission only . C6SZ-9A853-A 22.95
- 61-66 Throttle stop bumper, rubber (not shown) . . . . . C5SZ-9B720-A 3.95

## Throttle Stop Bracket



- 65-66 **NEW** Throttle stop bracket, Cruise-O-Matic transmission . . . . . C5SZ-7C431-A 33.95

## Automatic Choke Tubes & Insulators

How can you improve the look under your hood with 10 minutes of work? Install one of our reproduction choke tubes. The insulator is white & the ends are tarred like they were when your car rolled off the assembly line.

- 58-60 Tube with insulator, 352, steel as original . . . . . B8A-9819-H 32.95
- 59-60 Tube with insulator, 430, steel as original . . . . . B9ME-9819-A 32.95
- 1961 Tube with insulator, steel as original . C1SS-9819-A 30.95
- 1962 Tube with insulator, steel as original . C2SZ-9819-A 30.95
- 63-64 Tube with insulator, steel as original . C3SZ-9819-A 30.95
- 1965 Tube with insulator, steel as original . C5SZ-9819-A 30.95
- 1966 Tube with insulator, steel as original . C6SZ-9819-A 30.95
- 58-60 Insulator, white with tarred ends . . . B8S-9865-A 4.95
- 61-63 Insulator, white with tarred ends . . . C1SZ-9865-A 4.95
- 64-66 Insulator, white with tarred ends . . . C4SZ-9865-A 4.95

## Air Cleaner Wing Nut



- 58-66 1/4"-20 thread (shown) . . . . . 358871-S36B 1.95
- 61-63 Cadmium plated like original . . . . . 2HK33A 2.95

## Carburetor Top Gaskets to Air Cleaner

- 58-60 Rubber, 4 bbl carburetor . . . . . B8S-9654-A 2.95



- 62-63 3 "D" shaped gaskets, for 3x2 bbl set-up (3 required) . . . . . C1AZ-9654-A 4.95

## Linkage for 3x2 bbl Carburetors



- 62-63 **Save** Linkage rod kit, includes all the linkage pieces for a 390 3x2 barrel set-up, 4-piece kit (all 4 pieces can be purchased separately, see listings below) . . . . . C1AE-9700-KT 67.95 kit
- 62-63 Accelerator bell crank assembly for 390 3x2 bbl set-up . . . . . C1AE-9724-A 40.95
- 62-63 Accelerator bell crank to carburetor rod, for 390 3x2 bbl set-up . . . . . C1AE-9772-A 11.95
- 62-63 Throttle rod, front, for 390 3x2 bbl set-up . . . . . C1AE-9B841-A 11.95
- 62-63 Throttle rod, rear, for 390 3x2 bbl set-up . . . . . C1AE-9B842-A 11.95

## Cruise Control Bellows & Fluid



If your car was equipped with cruise control the bellows might be suffering from dry rot. Our new rubber bellows can cure your cruise control woes!

- 64-66 Cruise control bellows, rubber, 3" diameter . . . . . C7ZZ-9C735-A 33.95
- 64-66 Cruise control fluid, 1.97 oz., 1 bottle does 1 servo . . . . . C5AZ-19577-A 11.95



Accelerator Pedals

If your gas pedal is worn down it's time to get a new one! Whether it's the '58-'60, '61-'62 in all black rubber or the '63-'64, '65-'66 with their shiny stainless trim, they all will immediately improve the look of your interior.



- 58-60 Rubber... B5A-9735-A 10.95
61-62 Rubber... B7A-9735-A 11.95
63-64 Rubber with stainless trim... C4SZ-9735-A 55.95
65-66 Rubber with stainless trim... C5SZ-9735-A 55.95

Accelerator Pedal Linkage Parts



- 58-60 Pedal to linkage rod (shown) ... B8S-9727 4.95
58-60 Pedal rod seal ... B8S-9727-A 4.95
58-60 Pedal rod to floor seal ... BA-9738-S 2.95



- 61-64 Pedal to linkage retainer pin ... B7A-9727-B 2.95
61-66 Throttle return spring ... C1SZ-9737-B 4.95



- 61-66 Pedal linkage to firewall seal ... C1SS-9793-A 6.95

Accelerator Pedal Arm Return Bracket & Spring

- 61-66 Bracket, mounts to transmission bell housing bolt, except with 3x2 bbl carbs ... C1SZ-9741-B 22.95
61-66 Spring, except with 3x2 bbl carbs ... C1SZ-9737-B 4.95

Accelerator Rod Set



- 61-66 Includes rod from bellcrank to pedal & rod from carburetor to bellcrank, all clips & hardware are included ... C1SZ-9772-ST 33.95 set

Accelerator Rod Clip



- 61-66 Allows easy rod adjustments at the bellcrank, part of C1SZ-9772-ST listed above ... C3OZ-9A857-A 8.95

Remanufactured Generators

These generators are sold on an exchange basis. A \$20.00 core fee will be charged if your core is not received by the shipping date. This fee will be refunded if an acceptable core is received, in the rebuilders original box, within 90 days of the original purchase date.

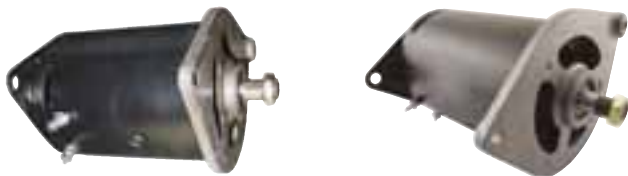

- 58-61 30 amp ... B6A-10002-A 99.95
61-62 40 amp ... B6MY-10002-A 99.95



Our remanufactured generators do not include a pulley. Pulley are not presently available from MAC's.

Ford Design Generator Parts

- 60-61 Armature, for 30 amp ... C1TZ-10005-A 24.95
60-62 End plate & brush assembly, rear ... C3AZ-10050-A 16.95
60-62 Brush set, .90" high x .93" wide x .29" thick ... C1AZ-10069-A 6.95 set



- 60-62 Front bearing ... 8BA-10094 11.95
60-62 Rear bearing ... B6A-10095-B 11.95
60-62 Bolt, 1/4"-20 x 6-9/16" ... C3AZ-10120-A 3.95
60-62 Front end plate ... B6A-10139-B 8.95



- 60-61 Field coil assembly, for 30 amp ... B6AZ-10175-D 19.95



## Generator Overhaul Kits

Give yourself peace of mind knowing that a burned out bearing or worn out brushes aren't going to leave you stranded out on the road—install a new set of brushes & front & rear bearings today!



**BUY a KIT & SAVE**

- 60-61 **NEW** Includes one each of the following:  
 C1AZ-10069-A brush set, 8BA-10094 front bearing, B6A-10095-B rear bearing & 2 of 91A-10057 brush springs, Ford & Mercury . . . . COAZ-10000-KT 30.95 kit
- 60-62 **NEW** Includes one each of the following:  
 C1AZ-10069-A brush set, 8BA-10094 front bearing & B6A-10095-B rear bearing, Ford & Mercury . . . . C2AZ-10000-KT 24.95 kit

## 30 Amp Generator Rebuild Kits

If you need to go beyond new brushes & bearings, we can help with that too! Check out the two rebuild kits listed below



**BUY a KIT & SAVE**

- 60-61 **NEW** 30 amp generator rebuild kit, includes one each of the following: C1AZ-10069-A brush set, 8BA-10094 front bearing, B6A-10095-B rear bearing & C1TZ-10005-A armature . . . . B6A-10002-KT 44.95 kit



**BUY a KIT & SAVE**

- 60-61 **NEW** 30 amp generator major rebuild kit, includes one each of the following: C1AZ-10069-A brush set, 8BA-10094 front bearing, B6A-10095-B rear bearing, C1TZ-10005-A armature & B6AZ-10175-D field coil . . . . B6A-10002-MKT 59.95 kit

## POWERGEN

Your friends will be fooled. They'll wonder why your headlights don't dim at idle. Tell them you have a secret. Tell them you stuffed an alternator into your generator housing. Tell them you have PowerGen—75 amps at highway speeds but, most importantly, 60 big amps at idle! This is the new way to go—get the reliability of an alternator, but the classic look of a stock generator.



- 58-64 With offset left hinge mount, painted black . . . . . 10346-82101 374.95
- 58-64 With offset left hinge mount, polished aluminum (shown) . . . . 10346-282101 425.95

## Generator Voltage Regulators

### Reproduction



- 1962 Lettered as original with "FoMoCo" logo & engineering number C2AF 10505A, black body with blue lettering . . . . . C2AF-10505-A 40.95

### Replacement Type



- 58-62 30 amp . . . . . C3TZ-10505-B 38.95
- 58-62 35 amp . . . . . C2AZ-10505-C 29.95
- 58-62 40 amp . . . . . C1TF-10505-D 43.95

**DON'T FORGET!** We carry decals for 1958-1960 voltage regulators, see our Decals on page 99.

## Generator Splash Shield



- 61-62 Rubber . . . . . C1AZ-10170-B 17.95

## Remanufactured Alternators

These alternators are sold on an exchange basis. A \$40.00 core fee will be charged if your core is not received by the shipping date. This fee will be refunded if an acceptable core is received, in the rebuilder's original box, within 90 days of the original purchase date.



- 63-64 Single pulley, 40 amp . . . . . 10346-A 74.95
- 65-66 Single pulley, 42, 55 amp . . . . . 10346-C 61.95



- 63-64 Double pulley, 40 amp . . . . . 10346-ADP 63.95
- 65-66 Double pulley, 42, 55 amp (shown). . . . . 10346-B 61.95

## Alternator Repair Kit

- 65-66 Includes bearings, brushes & the correct insulators . . . . . C8AZ-10346-KT 15.95 kit

## Alternator Rotor Assembly

- 65-66 **NEW** Alternator rotor assembly, all **except** with transistor ignition . . . . . C5DZ-10335-A 24.95

## Alternator Fan

The finishing touch to your alternator is our concours correct reproduction fan.

- 65-66 Gold (zinc dichromate), 13 blades . . . . . C5AZ-10A310-B 8.95





## Alternator & Air Conditioner Idler Pulley Mounting Brackets

1964	For all cars with A/C . . . . .	C4AZ-10A313-D	88.95
65-66	For cars with A/C but without a Thermactor pump (emissions air pump). . . . .	C9TZ-10A313-A	88.95
64-66	For cars with A/C but without a Thermactor pump (emissions air pump), for adjusting belt tension . . . . .	C4MY-10145-A	25.95

## Alternator Front Bearing



63-66	Except 70, 90 or 100 amp alternator. . .	.8BA-10094	11.95
-------	------------------------------------------	------------	-------

## Alternator Splash Shield

1963	Mounts to frame rail . . . . .	C3SZ-10274-A	11.95
------	--------------------------------	--------------	-------

## Alternator Voltage Regulator Plug & Wires

MAC's has a simple solution to repairing that corroded plug on your voltage regulator, our aftermarket plug & wires. Splice the wires into your harness & plug it in!



63-66	Plug & wires, for voltage regulator, to replace corroded plug . . . . .	C5AZ-14305-A	6.95
-------	-------------------------------------------------------------------------	--------------	------

## Alternator Voltage Regulators

### Reproduction

All reproduction voltage regulators are lettered as original with the "FoMoCo" or "Autolite" logos & the correct engineering numbers in the original colors. All are rated for use with alternators up to 55 amps.

1963	"FoMoCo" logo, black body with yellow lettering . . . . .	C3TF-10316-F	32.95
1964	Except convertible or air conditioning, "FoMoCo" logo, black body with silver lettering . . . . .	C4UF-10316-F	32.95
1964	Voltage regulator, all convertible or with air conditioning, "FoMoCo" logo, black body with yellow lettering . . . . .	C4TF-10316-F	32.95
1965	Before 12-64, except convertible or air conditioner, "FoMoCo" logo, black body with silver lettering . . . . .	C5AF-10316-F	32.95
1965	Before 12-64, convertible or with air conditioner, "FoMoCo" logo, black body with yellow lettering . . . . .	C5TF-10316-F	32.95
65-66	After 12-64, except convertible or air conditioner, "Autolite" logo, black body with silver lettering . . . . .	C5AF-10316-A	32.95



65-66	After 12-64, convertible or all with air conditioning, "Autolite" logo, black body with yellow lettering. . .	C5TF-10316-A	32.95
-------	---------------------------------------------------------------------------------------------------------------	--------------	-------

## Replacement-Type



63-66	Aftermarket replacement, can be used on alternators up to 55 amp, not to be used with transistorized ignition . . . . .	C3SZ-10316-B	25.95
-------	-------------------------------------------------------------------------------------------------------------------------	--------------	-------



Sorry, we do not carry any voltage regulators that will work with the factory transistorized ignition.

## Script Batteries

What item under the hood do classic car owners most often overlook? You're right, it's the battery. We now have the perfect addition to keep your classic "period correct." All batteries are heavy-duty & are shipped "damp-dry" from the factory & can be shipped by UPS. You provide the electrolyte, which you can purchase locally. A \$45.00 flat shipping fee applies within the continental U.S. whether shipped to you or picked up at our store. Batteries can only be shipped by ground/surface within the U.S. because of government regulations.



58-63	600 cold cranking amps, group 29, "Power Punch" embossing, 13" x 5-1/2" x 9", tar top . . . . .	29N-POWERPUNCH	280.95
64-66	585 cold cranking amps, group 24, "Autolite Sta-Ful" embossing 10-3/4" x 6-3/4" x 9", molded top . . . . .	24F-AUTOLITE	328.95
58-63	780 cold cranking amps, group 27, "Power Punch" embossing, 12" x 6-3/4" x 9", molded top . . . . .	27FHD-POWERPUNCH	304.95

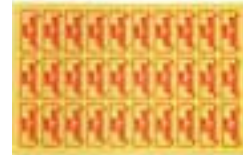

ALL	Battery mat, absorbs & neutralizes battery acid & vapors, trim to fit . . . . .	BATMAT	5.95
-----	---------------------------------------------------------------------------------	--------	------



ALL	Battery protector, seals terminals & prevents corrosion, cuts current loss, 5 oz. spray can . . . . .	RSP15 *	3.95
-----	-------------------------------------------------------------------------------------------------------	---------	------

\* HAZARDOUS MATERIAL can only be shipped by ground/surface within the U.S. because of government regulations.



## Battery Disconnects & Bracket

MAC's battery disconnect will give you & your car a measure of security. Unscrew the knob when you leave the car & if someone does try to start it, the in-line fuse will blow. It's easy to install & easy to operate. What could be easier? Call today & place your order!



ALL	Battery disconnect	A14300C	12.85
ALL	Battery disconnect, remote mount so it's hidden from view	A14300D	24.75
ALL	Bracket, for remote mount battery disconnect	A14300DB	7.50

## Battery Trays

Get rid of that rusty tray today! Call MAC's & we'll ship a brand new one out right away.



58-60	Brackets welded on as original	B8S-10732-A	55.95
61-66	Before 12-1-65, for use with bottom hold-down clamp	C2SZ-10764-A	23.95
1966	After 12-1-65, for use with top hold-down clamp	C9AZ-10764-AR	32.95

We carry the correct hardware to attach your battery tray-see page our Hardware section, pg 240.

## Battery Hold-Down Clamps

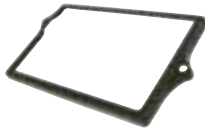

58-60	Battery hold-down clamp, black powder coat, group 27 battery	B8S-10718	32.95
-------	--------------------------------------------------------------	-----------	-------



58-60	Battery hold-down clamp, group 29 battery	B6A-10718-C	19.95
-------	-------------------------------------------	-------------	-------

61-66	Battery hold-down clamp, clamps over lip at bottom of battery, before 12-1-65	C5DZ-10718-A	6.95
-------	-------------------------------------------------------------------------------	--------------	------



1966	Battery hold-down clamp only, clamps on top of battery, after 12-1-65	C5AZ-10718-A	6.95
------	-----------------------------------------------------------------------	--------------	------

1966	Hold-down clamp bolt & nut kit, 4 pieces	C5AZ-10718-KT	9.95 kit
------	------------------------------------------	---------------	----------

## Battery Hold-Down Bolts



58-66	Battery hold-down bolt & nut kit	C1AZ-10756-KT	1.95 kit
65-66	Battery hold-down bolt & nut kit, 5/16" x 8-5/8" long, for top clamp only, after 12-1-65	DOAZ-10756-KT	4.95 kit

## Battery Heat Shield

58-59	Battery heat shield	B6S-10757-A	41.95
-------	---------------------	-------------	-------

## Battery Corrosion Arrestors



ALL	Sold as a pair	C1AZ-10A717-B	2.95 pair
-----	----------------	---------------	-----------

## Replacement Battery to Ground Cable

59-60	25" long, replacement type	14300-513	14.95
-------	----------------------------	-----------	-------

## Battery Hardware

61-63	3 faceted-flange-head black oxide finish bolts	2HK36A	5.95 kit
64-66	4 faceted-flange-head bolts & 4 faceted-flange lock-nuts black oxide finish	2HK36B	7.95 kit
1966	3 hex washer-head bolts & 3 faceted-flange lock-nuts black oxide finish	2HK36C	5.95 kit

## Reproduction Starter Cable Brackets & Grommets

On 1958-1960 T-Birds the original routing of the starter cable was from the relay to a bracket on the firewall, then to another bracket on the bell housing, then to the starter. Our bracket & grommet sets allow you to duplicate this original cable routing.



58-60	On firewall	B7S-14431-F	7.95
58-60	On bell housing	B7S-14431-B	7.95

## Remanufactured Starter Motors

These starters are sold on an exchange basis. A core fee of \$20.00 will be charged if your core is not received by shipping date. The core fee will be refunded if an acceptable core is received within 90 days of purchase date, in the rebuilder's original package.



58-61	3 bolt mount, includes drive	B6A-11002-A	114.95
62-64	3 bolt mount, includes drive	C2SZ-11002-A	98.95
65-66	3 bolt mount, includes drive	C3OZ-11002-C	79.95

65-66	Starter bolt set, for 390 & 428	B6AL-1604	4.95 set
-------	---------------------------------	-----------	----------



## Reproduction Battery Cables & Ground Strap



- 1958 Reproduction battery cable set . . . B8S-14300-ST 54.95 set
- 59-60 Reproduction battery cable set . . . B9S-14300-ST 54.95 set
- 1961 Reproduction battery cable set . . . C1SF-14300-ST 54.95 set



- 1962 Reproduction battery cable set . . . C2SZ-14300-ST 54.95 set
- 1963 Reproduction battery cable set . . . C3SZ-14300-ST 54.95 set
- 64-65 Reproduction battery cable set (not shown) . . . C4SZ-14300-ST 54.95 set
- 1966 Reproduction battery cable set (not shown) . . . C6SZ-14300-ST 54.95 set
- 58-62 Reproduction ground strap, attaches to back of cylinder head . . . FEV-14303-B 11.95

## Starter to Bellhousing Seal



- 58-62 Starter to bellhousing seal . . . C2AZ-6436-A 10.95

## Starter Parts



- 58-66 Brush end plate bushing . . . 18-11052 1.15



- 58-64 **NEW** Post repair kit, includes new post, insulators, washers & nuts . . . A9AZ-11102-B 6.95 kit



- 58-64 Brushes (2 required) (shown) . . . 18-11057 5.75
- 58-64 Cover band . . . B1TZ-11126-A 5.95
- 58-64 Drive end plate & bushing . . . C2AZ-11130-A 16.95
- 58-61 Drive end housing bushing, 5/8" ID x 13/16" OD x 1-15/32" long (shown) . . . 1CM-11135-A 3.95

## Starter Rebuild Kit



- 62-64 **NEW** Includes armature, brushes, starter drive bushing, rear bushing & a post repair kit . . . C2AZ-11002-KT 29.95 kit

## Starter Drives



- 58-61 Starter drive . . . C1AZ-11350-A 43.95
- 62-64 Starter drive . . . C2AZ-11350-C 32.95
- 65-66 Starter drive . . . C6VY-11350-A 31.95

## Starter Relays (Solenoid)



The starter relay, or solenoid, of Ford electrical systems is usually located in plain sight at the top of the passenger side of the engine bay. This makes it very convenient for service work. This also makes it the **frequent target of judges & Ford admirers** who tend to look into your engine compartment when you have the hood raised at a car show.

Like any starter relay, Ford units work hard over many years of start-up sequences, consequently, many of them have finally worn out & had to be replaced. Unfortunately, some of them will have been replaced with universal "fits-all" solenoids that do not look right under the hood of any Ford, much less your favorite cruiser!

Worse yet, some of those replacement units are not quality units & might fail at the worst possible time. Our Ford restoration professionals are happy to help you solve the problem, with a brand new reproduction unit with authentic markings & superior components inside. You'll receive a terrific, high-quality starter relay that not only looks **authentic** but will give you years of reliable service.



## Reproduction

For that extra touch of authenticity, one of our reproduction starter relays is as good as it gets. They all feature a finely detailed black case, correct lugs, correctly styled hardware & have the correct markings stamped into the metal bracket on top, just like the originals.



- 1965 Used in early 1965, fine thread lugs, stamped "2701966" & "FoMoCo" in script . . . B6A-11450-S 43.95
- 65-66 Used from late 1965-1966, fine thread lugs, stamped & "FoMoCo" in block letters . . . B6A-11450-B 40.95

## Replacement-Type

- 58-66 . . . B6A-11450-A 11.95





**“Ignitor” Ignition Substitute**

**Never Fight with a set of points again!**

Install the IGNITOR by Pertronix. The breakerless electronic ignition substitute. Get longer plug life, better fuel economy & increased horsepower!! (Not for transistorized ignition).



58-66 The IGNITOR, all engines. . . . . 12127-1281 75.95

**Flame Thrower® Ignition Coils**

The Flame Thrower is a high-performance 40,000 volt ignition coil. It is the best coil to use with our Pertronix IGNITOR™ breakerless points & condenser replacement. (Not for transistorized ignition).



58-66 Flame Thrower ignition coil, black, all engines. . . . . 12029-40011 34.95  
 58-66 Flame Thrower ignition coil, chrome, all engines. . . . . 12029-40001 38.95

**Flame Thrower® Wire Set**

We now carry “Flame Thrower Wires,” the perfect compliment to the “IGNITOR” & “FLAME THROWER” coil listed above. These are high performance wires in “disguise” as they are all black with no markings.

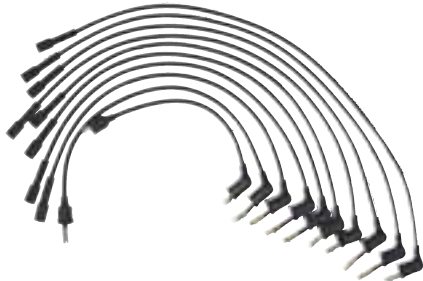

58-66 Flame Thrower wire set, 7.0 mm for a stock look . . . . . 12259-708105 43.95 set

When you consider how many different systems must operate within a distributor, you can easily see why they are so critical to the performance of any internal combustion engine. First, there is the primary ignition circuit, then the secondary ignition circuit, the timing system, the vacuum system, the lubrication system...whew!

So many things can go wrong; it is amazing that they work as well as they do! Here at MAC's, we know how important it is for your classic to start, run & perform like a new car. Because we believe that the distributor is such a vital ingredient in the way your engine runs, we offer these exceptional quality remanufactured distributors.

Our quality control starts with the cores we use for remanufacturing, which ensures that you will receive a quality remanufactured unit when you place your order. Call today.

**Remanufactured Distributors**

This remanufactured distributor is sold on an exchange basis. A \$30.00 core fee will be charged if your acceptable core is not received by shipping date. The core fee will be refunded if an acceptable core is returned within 90 days of purchase date. Your core must be returned in the rebuilder's original package.

This modern service replacement uses the '60 & up style condenser. For future tune-ups, remember to use the 60-66 condenser, our B9AZ-12300-A.



58-60 352, single vacuum . . . . . 12127-2108 69.95  
 61-66 390 & 428, single vacuum. . . . . 12127-2108 69.95

**Distributor Gear & Pin**



58-66 Gear, 15 teeth, 352, 390 & 428, you will need a new gear pin 61489-S listed below. . . . . FAB-12390-C 13.95  
 58-66 Pin, used to secure gear onto shaft, all engines, not reusable when you replace your gear . . . . . 61489-S 0.95

**Distributor Vacuum Advances**

58-59 Off-center linkage arm, replacement . B9AF-12370-A 24.95  
 60-64 Off-center linkage arm, replacement . B9AF-12370-A 24.95



60-64 Centered linkage arm . . . . . C5AZ-12370-A 24.95  
 65-66 Centered linkage arm . . . . . C5AZ-12370-A 24.95

**Distributor Vacuum Lines**

58-61 OE steel, 352 & 390 . . . . . B8S-12371 16.95  
 58-61 Stainless steel, 352 & 390 . . . . . B8S-12371-SS 22.95  
 62-63 OE steel, single 4 bbl engine . . . . . C2SZ-12371 16.95  
 62-63 Stainless steel, single 4 bbl engine . . . . . C2SZ-12371-SS 22.95  
 64-66 OE steel, 390 & 428 . . . . . C4SZ-12371 16.95  
 64-66 Stainless steel, 390 & 428 . . . . . C4SZ-12371-SS 22.95



The ignition coil is where the high voltage, which fires your spark plugs, is created. A weak spark at the coil will result in weak ignition at the spark plugs, which can result in fouled plugs or other engine performance issues.

Take a look at the coil in your car. Is it very old? Is the metal case dented, damaged, swollen or rusted? What about the bakelite tower at the top? Are there any tiny cracks or chips around the crown? Is there any corrosion inside the tip?

If you answered "yes" to any of the above vital questions, call now & get a brand new ignition coil. MAC's offers a correct-appearing reproduction coil with black body & mustard-colored top for restorers & a Flame Thrower® Petronix coil for high performance Ford lovers who want a little extra spark in their classic car.

**Ignition Coils**

Choose from our replacement type that is perfect for the "daily driver" to our concours correct mustard top coil reproduction.



- 58-66 All black, not for transistor ignition . . .B6A-12029-B 21.95
- 58-66 Black body with mustard top, not for transistor ignition . . . . . B6A-12029-MT 53.95

**Ignition Coil Bracket**

- 64-66 Painted black, replacement type . . .C4DZ-12043-A 12.95

**Ignition Coil Resistor (Circuit Breaker)**



- 58-59 . . . . . B8A-12250-A 7.95

Your spark plug wires hang right up there where everyone who looks under your hood will see them & they must carry the high-voltage spark signal from the distributor to the spark plug, without losing any power along the way. That's a pretty tall job!

So how do you keep your spark plug wires looking good & performing perfectly? Install a brand new authentic reproduction spark plug wire set from the Ford restoration experts at MAC's Antique Auto Parts. Complete with original factory-style engineering numbers & logo on the boots, these premium quality wires will look terrific on any classic.

Best of all, they're made from top grade materials under rigid inspection processes & will perform as well as they look.

**Reproduction Spark Plug Wire Sets**

These reproduction sets are newly manufactured parts made to appear like the O.E.M. equipment. In some cases the availability of material, color, or reproduction techniques might have resulted in very minor differences from the original. These are not O.E.M. duplicates, but are the closest reproduction available.

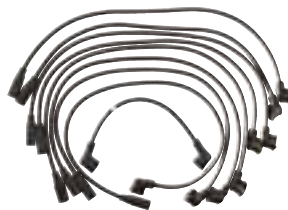

- 60-64 352 & 390 . . . . . 12259-19-ST 56.95 set
- 65-66 352, 390 & 428 without smog equipment . . . . . 12259-28-ST 56.95 set

**Replacement Spark Plug Wire Set**



- 58-66 Spark plug wire set, 352, 390 & 428, **Motorcraft** . . . . . E5PZ-12259-GR 42.95 set

**Spark Plug Wire Separators (as required)**



- 58-66 Spark plug wire separator, comb-shaped, holds 4 plug wires in place . . . . . B6A-12297-A 1.95
- 58-66 Spark plug wire separator, clips on valve cover, holds 4 plug wires in place . . . . . B8Q-12297-A 3.95

**Spark Plug (8 required)**



- 58-66 18mm, 352, 390, 428 & 430, **Motorcraft** . . . . . 12405-D 2.95

ALL **NEW** **Permatex Anti-Seize Lubricant**, a blend of aluminum, copper & graphite lubricants. Perfect for easy removal of spark plugs & cylinder or exhaust head bolts, 1 oz. tube . . . . . RSP102 3.95



**Distributor Caps**



- 58-66 Black, all engines, replacement, aluminum contacts . . . . . B7A-12106-A 8.95
- 58-66 Black, all engines, reproduction, brass contacts . . . . . B7A-12106-EARLY 12.95

**Distributor Tune-Up Kit**

**BUY a KIT & SAVE**



- 60-66 Kit, 352, 390, 428 & 430, kit includes: (1) A12151CPT, (1) B9AZ-12300-A & (1) B7A-12200-A . . . . . COTZ-12000-AKT 18.95 kit

**Individual Parts**

- 58-66 Points, 352, 390, 428 & 430 . . . . . A12151CPT 3.40
- 58-59 Condensers, 352 & 430 . . . . . B7A-12300-C 4.95
- 60-66 Condensers, 352, 390, 428 & 430 . B9AZ-12300-A 9.95
- 58-66 Rotor, 352, 390, 428 & 430 . . . . . B7A-12200-A 5.95

**Distributor Cam Lube**

Add longer life to your distributor came & points, apply sparingly every 2-2,500 miles!



- 58-66 Made with silicone for superior lubrication & long life, generous 7/8 oz. tube . . . . A12210L 6.25



Take a good look at your lights, lenses & overall brightness of your lighting system. Old faded lenses & corroded reflectors cause your lights to look dim. The brightness of your light bulbs is generally effected by ground wires & sockets while their brilliance is enhanced by the plastic lenses.

Bright & beautiful lights are an asset to any nice car & MAC's has the parts to restore the beauty of your light systems.

You will love the restored appearance that new bezels, lenses & gaskets will add to your car. Find all of the parts you need in MAC's comprehensive listings for your Ford. **Hint:** Always take pictures of your car with the lights on. It will enhance the beauty of your ride.

**Sealed Beams (2 required)**

Add a measure of authenticity with our sealed beams with the "FoMoCo" script on them!



- 58-66 Low beam . . . . . B8AZ-13007-A 6.95
- 58-66 Low beam, "FoMoCo" script . . . B8AZ-13007-AS 17.95
- 58-66 High beam . . . . . B8AZ-13007-B 6.95
- 58-66 High beam, "FoMoCo" script . . . B8AZ-13007-BS 17.95

**Headlight Retaining Ring Hardware**



- 64-65 **NEW** Hardware set, for headlight retaining ring . . . . . 2HK40F 2.95 set

**Headlight Adjuster Kits (2 kits required)**

- 61-63 Includes 2 springs, 4 screws, 2 nuts, 2 nuts with brackets, 4 small rivets & 2 large rivets . . . . . 2HK40H 26.95 kit
- 64-65 Includes 2 springs, 4 screws & 4 nuts with brackets . . . . . 2HK40J 46.95 kit
- 1966 Includes 2 springs & 4 adjusting screw/nut assemblies . . . . . 2HK40K 30.95 kit

**Headlight Adjusting Springs (4 required)**



- 58-60 . . . . . B8A-13031-A 6.95
- 61-63 . . . . . C1VF-13031-A 2.95
- 64-66 . . . . . C2OZ-13031-A 1.95

**Headlight Adjusting Nuts (8 required)**



- 62-63 . . . . . C2TZ-13181-AR 3.95
- 64-65 With plastic insert . . . . . C3MY-13181-A 3.95

**Headlight Bucket Hardware**



- 61-63 **NEW** Set includes 4 hex washer-head bolts, black oxide finish. . . . . 2HK40A 4.95 set
- 64-65 **NEW** Kit includes 4 hex washer-head screws, 4 black oxide finish spring-type "J" clips, 4 hex nuts & 4 flat washers. . . . . 2HK40B 6.95 kit
- 1966 **NEW** Kit includes 4 hex-head bolts, 4 flat washers, 4 faceted flange-head black oxide finish bolts, 2 black oxide finish faceted flange lock nuts & 4 threaded "U" nuts. . . . . 2HK40C 11.95 kit

**Headlight Bucket & Door Gaskets**

Being on the front of the car, these gaskets bear the brunt of all the wind & rain. On most cars they are dry rotted & cracked to the point that when you remove the headlight doors they just crumble & fall off. Buy new ones today!



- 58-60 Bucket mounting gaskets . . . . . B8AZ-13044-A 5.95 pair
- 58-60 Door seals, black, install between the headlight door & fender, can be painted to match car . . . . . B8S-13044-AA 11.95 pair

**Headlight Doors**



- 61-63 Chrome, right or left (2 required) (shown) . . . . . C1SZ-13064-AR 47.95
- 64-65 Chrome, right . . . . . C4SZ-13064-A 99.95
- 64-65 Chrome, left. . . . . C4SZ-13064-B 99.95

**Hardware**

- 61-63 Headlight door screw set, 4 oval-head Phillips type . . . . . 2HK40D 2.95 set
- 64-65 Headlight door hardware kit, 6 oval-head Phillips screws & 6 black oxide finish, spring type U-nuts. . . . . 2HK40E 5.95 kit
- 1966 Headlight door hardware kit, 4 oval-head Phillips screws & 4 black oxide finish, spring type U-nuts. . . . . 2HK40G 6.95 kit

**Headlight Bulb Pigtails (2 required)**



- 58-66 For 3-prong sealed beams, low beams in 2 or 4 lamp system . . . . . 01A-13076-U 2.25
- 58-66 For 2-prong sealed beams, high beams in 4 lamp system. . . . . B8A-13076-A 2.95

**Headlight Sockets & Wires (2 required)**

- 1959 14" long. . . . . B9S-13076-A 29.95
- 60-63 23" long. . . . . B9AF-13076-A 26.95





**Parking Light Body** (2 required)

58-60 Steel, with correct wire pigtail . . . . . B8S-13206-A 68.95

**Parking Light Lenses**



58-60 Plastic, clear . . . . . B8S-13208-PR 14.95 pair  
61-63 Plastic, clear . . . . . C1SF-13208-PR 15.95 pair  
1963 Plastic, amber . . . . . C3SZ-13208-PR 17.95 pair



64-65 Plastic, clear (2 required) . . . . . C3AZ-13208-B 5.95  
1966 Plastic, clear, right . . . . . C6SZ-13208-AR 34.95  
1966 Plastic, clear, left . . . . . C6SZ-13209-AR 33.95

**Hardware**

58-60 Screw (4 required) . . . . . 354899-S 1.25  
61-63 Screw set, 4 oval-head Phillips type . . . . . 2HK41C 2.95 set  
61-65 Screw, Phillips type with special small head (4 required) . . . . . 371476-S 1.95

**Parking Light Lens Gaskets**



58-60 . . . . . B7S-13211-PR 3.95 pair  
61-63 . . . . . C1SF-13211-PR 4.95 pair



64-65 . . . . . C1AB-13211-PR 3.95 pair  
1966 . . . . . C6SZ-13211-PR 3.95 pair

**Parking Light Pigtail & Socket** (2 required)



58-60 Parking light pigtail & socket, exact reproduction . . . . . B8S-13410-A 19.95

**Parking Light Socket & Wire** (2 required)

58-60 27" long . . . . . FEV-13234-A 24.95

**Parking Light Body Parts**

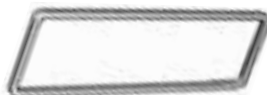

58-60 Body to fender pad . . . . . B7S-13217-A 2.95 pair  
61-63 Screw set, 4 pan-head Phillips type . . . . . 2HK41A 2.95 set  
64-66 Hardware set, 4 faceted flange lock-nuts . 2HK41B 3.95 set

**Map Light Switch & Lenses**

58-59 Switch & wires, includes attaching rivets . . . . . B8S-13764-A 9.95  
58-60 Lens, fits convertible only . . . . . B8S-13761-A 10.95  
61-63 Lens . . . . . B8S-13761-A 10.95



64-66 Lens, goes on the center part of the dash . . . . . C4SZ-13761 11.95 pair

**Interior Pillar Light Assembly** (2 required)



64-66 Interior pillar light assembly, chrome with white plastic lens, on roof pillar, all body styles in 1964 & 1965, only body style 63A in 1966 . . . . . C4SZ-13776-BR 36.95

**Dome & Courtesy Light Lenses**

Now you can replace those ugly yellowed dome & courtesy light lenses. Whether it's **Genuine Ford** or an excellent reproduction these lenses will brighten up your interior. Call us today to place your order!

**Dome Light Lenses**



58-60 White . . . . . B8S-13783-BR 5.95



61-63 White plastic (2 required) . . . . . C1SZ-13783-BR 2.95

**Courtesy Light Lenses**

63-64 White plastic, on door panel, (2 required) . . . . . C1SZ-13783-BR 2.95  
1965 White plastic, on roof pillar, (2 required) . . . . . C1SZ-13783-BR 2.95  
1966 White plastic, on roof pillar, only body style 63A in 1966, (2 required) . . . . . C1SZ-13783-BR 2.95



1966 Rectangular, only on Town Hardtop & Town Landau (2 required) . . . . . C6SZ-13783-A 11.95

**Hardware**

63-64 Courtesy light bezel screw set, 4 oval-head Phillips screws . . . . . 2HK91P 2.95 set  
65-66 Courtesy light bezel screw set, 4 oval-head Phillips screws . . . . . 2HK42A 2.95 set  
1966 Roof mounted courtesy light bezel screw set, 4 pan-head Phillips screws, Town Coupe & Town Landau models . 2HK42B 2.95 set



**Door Courtesy Light Assemblies** (2 required) \_\_\_\_\_

A complete assembly that you can plug into your harness, 2 screws & it's installed!



- 63-64 Includes red & white lenses . . . . . C3SZ-13786-A 29.95
- 65-66 Includes red & white lenses, with wiring (shown) . . . . . C5ZZ-13786-A 38.95

**Courtesy Light Actuator Wedge** (2 required) \_\_\_\_\_



- 64-66 Mounted on door, depresses courtesy light switch on pillar . C4SZ-13A786-C 8.95

**Dome Light Assembly & Bezel** \_\_\_\_\_

- 61-63 Dome light assembly, brushed aluminum housing with 2 ivory plastic lenses. . . . . C1SF-13779-A 28.95



- 58-60 Dome light bezel, chrome, body style 63A. . . . . COTF-13787-AR 16.95

**Tail Light Socket** (4 required) \_\_\_\_\_



- 58-60 With wire pigtail . . . . . B8S-13410-A 19.95

**Tail Light Body to Door Pad** (6 required) \_\_\_\_\_



- 1960 . . . . . COSB-13420 8.95

**Tail Light Housing to Body Pads** (2 required) \_\_\_\_\_

Years of foul weather take their toll on tail light pads, seals & gaskets causing them to dry rot & develop cracks that allow water to seep into your tail light assemblies. Replace yours today & you'll be rewarded with fewer shorted out bulbs & put an end to the corrosion of your reflectors so you'll have turn signals that blink & stop lights that shine brightly!



- 1961 . . . . . C1SF-13420-B 7.95
- 62-63 (shown) . . . . . C2SB-13420-A 7.95

**Tail Light Buckets** (2 required) \_\_\_\_\_



- 1961 . . . . . C1SB-13434-A 72.95
- 62-63 . . . . . C2SZ-13434-A 77.95

**Tail Light Bucket Retainers** (2 required) \_\_\_\_\_



- 1961 Steel . . . . . C1SB-13A480-A 28.95
- 62-63 Steel . . . . . C2SB-13A480-A 28.95

Plastic lenses are another easy fix. Old lenses & gaskets that are unbroken will sometimes be left in place by a restorer, until that person parks next to a similar car with a beautiful brand new reproduction lenses. The old faded & dull lenses look very weak by comparison & dirty, cracked gasket edges look shabby sticking out from behind the lens. One comparative look from the new restorer & at the next show you can be sure that BOTH cars will have new lenses. Put new light bulbs, lenses, gaskets & connectors on your Bird & brighten your "outlook!"

**Tail Light Lenses** (2 required) \_\_\_\_\_

All lenses will fit for right or left sides.



- 58-59 Clear lens in center . . . . . B8S-13450-B 38.95
- 1960 No back-up lens, all red, "Ford" logo molded in (4 required) . . . . . COSF-13450-B 24.95
- 1960 With back-up lens . . . . . COSF-15514-C 32.95



- 1961 All red, without "Ford" logo . . . . . C1SZ-13450-A 33.95
- 1961 All red, with "Ford" logo . . . . . C1SZ-13450-AR 44.95
- 62-63 All red, with "Ford" logo . . . . . C2SZ-13450-A 43.95



- 1964 Right or left, all red . . . . . C4SZ-13450-AR 71.95
- 1965 Right or left, all red . . . . . C5SZ-13450-C 36.95



- 1966 Center, with back-up lens, this lens is bowed 1/8" in the center, red & clear plastic, draw screws in slowly & alternate side to side & top to bottom to even out pressure . . . . . C6SZ-13450-B 69.95
- 1966 Right or left, all red . . . . . C6SZ-13450-AR 69.95



Tail Light Hardware

Table with 4 columns: Year, Description, Part Number, Price. Includes items like lens screws and body hardware sets.

Center Tail Light Emblem



Table with 4 columns: Year, Description, Part Number, Price. Includes chrome emblem for 1966.

Tail Light Lens to Housing Gaskets

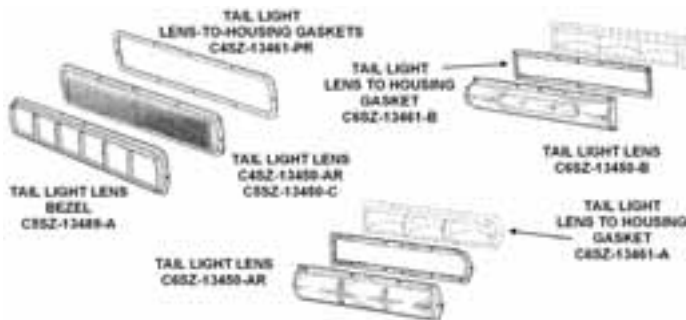

Table with 4 columns: Year, Description, Part Number, Price. Lists gasket sets for various years.

Tail Light Lens Bezels & Trims



Table with 4 columns: Year, Description, Part Number, Price. Lists bezels and trims for 1962 and 1963.



Table with 4 columns: Year, Description, Part Number, Price. Includes bezel with vertical bars for 1965.

Back-Up Light Bezel (2 required)



Table with 4 columns: Year, Description, Part Number, Price. Includes chrome bezel for 64-65.

Back-Up Light Lenses

1958-1960 & 1966 have the back-up light lens built into the tail light lens.



Table with 4 columns: Year, Description, Part Number, Price. Lists back-up light lenses for 58-59, 1960, and 61-63.



Table with 4 columns: Year, Description, Part Number, Price. Includes clear glass and backup lens for 64-65.

Hardware

Table with 4 columns: Year, Description, Part Number, Price. Lists hardware for back-up light lenses.

Back-Up Light Gaskets (2 required)



Table with 4 columns: Year, Description, Part Number, Price. Lists gaskets for 61-63 and 64-65.



Table with 4 columns: Year, Description, Part Number, Price. Includes housing to body gasket for 64-66.







## Interior Bulbs

58-62	A/C control panel	13466-0057	1.95
63-66	A/C control panel	13466-1895	0.95
58-66	Ashtray	13466-1445	1.95
1958	Clock	13466-0057	1.95
1959	Clock	13466-1816	1.95
1960	Clock	13466-0057	1.95
61-63	Clock	13466-1816	1.95
64-66	Clock	13466-1895	0.95
63-66	Courtesy light—door mounted (except California)	13466-1004	1.95
1966	Courtesy light—door mounted (California)	13466-0090	1.95
58-66	Dome	13466-1003	1.95
58-62	Glove box	13466-0057	1.95
63-64	Glove box	13466-1445	1.95
65-66	Glove box	13466-0631	1.95
58-62	Heater control panel	13466-0057	1.95
63-64	Heater control panel	13466-1895	0.95
65-66	Heater control panel	13466-1445	1.95
58-62	High beam indicator	13466-0057	1.95
63-66	High beam indicator	13466-1895	0.95
58-62	Ignition switch light	13466-0057	1.95
1963	Ignition switch light	13466-1445	1.95
64-66	Ignition switch light	13466-1895	0.95
58-59	Instrument panel	13466-0057	1.95
60-62	Instrument panel	13466-0057	1.95
63-66	Instrument panel	13466-1895	0.95
58-62	Map light	13466-0089	1.95
63-66	Map light	13466-0631	1.95
58-62	Parking brake warning	13466-0057	1.95
63-66	Parking brake warning	13466-1895	0.95
64-66	Pillar light (body style 63A & 63B)	13466-1003	1.95
64-65	Seat belt warning	13466-1895	0.95
1966	Seat belt warning	13466-1445	1.95
58-62	Speedometer dial	13466-0057	1.95
1963	Speedometer dial	13466-1816	1.95
1964	Speedometer dial	13466-1895	0.95
65-66	Speedometer dial	13466-1445	1.95
58-63	Transmission selector dial	13466-1445	1.95
1964	Transmission selector dial	13466-0158	1.95
65-66	Transmission selector dial	13466-0194	0.95
60-62	Trunk light	13466-0089	1.95
63-66	Trunk light	13466-0631	1.95

## Exterior Bulbs

1958	Back-up	13466-1141	1.95
1959	Back-up	13466-1003	1.95
60-63	Back-up	13466-1141	1.95
64-65	Back-up	13466-1076	2.95
1966	Back-up	13466-1156	1.95
58-62	Parking light	13466-1034	1.95
1963	Parking light	V13465F	0.75
63-66	Parking light	13466-1157NA	1.95
58-62	Tail light	13466-1034	1.95
63-66	Tail light	V13465F	0.75
58-62	License plate light	V13465D	0.80
63-66	License plate light	13466-0097	1.95
64-66	Turn signal indicator (fender mounted)	13466-0053	1.95



13466-1034

## Light Bulb Pliers



ALL **NEW** Assists in removing broken, brittle or corroded bulbs from sockets . . . . . TOOL-BULB 22.50



## Replacement Horns



- 58-64 High pitch, "seashell" type, looks very similar to original . . . B8A-13832-AR 44.95
- 58-64 Low pitch, "seashell" type, looks very similar to original . . . B8A-13833-AR 44.95



- 58-66 High pitch, plastic, aftermarket . . . B8A-13832-A 23.95
- 58-66 Low pitch, plastic, aftermarket . . . B8A-13833-A 23.95

### Mounting Bolt Sets

- 61-63 1 black oxide finish faceted-flange head bolt & 1 flat washer . . . . . 2HK44A 2.95 set
- 64-65 4 black oxide finish faceted-flange head bolts . . . . . 2HK44B 5.95 set
- 1966 2 black oxide finish faceted-flange head bolts . . . . . 2HK44C 2.95 set

## Horn Ring

- 58-60 Horn ring . . . . . B8SZ-13A805-A 162.95

## Horn Feed Wire (2 required)

- 1959 22" long PCV wire . . . . . FFV-14440-A 5.95

## Horn Ring Ornaments

From '58 thru '60 all cars equipped with power steering got a special treatment on the horn ring. Add one of our ornaments & the center of your steering wheel will look like brand new!



- 1958 With power steering, black plastic . . . B8S-3636-A 26.95
- 59-60 With power steering, white plastic . . . B9S-3636-A 26.95

## Horn Button Insulator



- 58-60 Horn button insulator . . . . . B8S-3672-A 2.95

## Horn Brush & Insulator



- 61-66 Horn brush & insulator . . . . . C2OZ-13A821-AR 6.95

## Horn Relays



- 58-63 . . . . . B8C-13853-A 9.95
- 64-65 . . . . . C4AZ-13853-A 8.95
- 1966 Used with speed control only . . . . . B8C-13853-A 9.95



Take a good look at the wiring on your Thunderbird. Does it consist of makeshift plugs, mismatched jumper wires & suspicious looking wads of electrical tape? Many years can take a heavy toll on connectors, leaving them so corroded that little or no current will pass thru.

MAC's wiring harnesses are made to meet the highest standards, so you can unplug the "bad" & plug in the "good." We use the correct color wires with correct color tracers so you can refer to an original wiring diagram for proper routing. The plugs are just like the originals, simply plug them in!

## Dash to Engine Gauge Feeds

- 58-59 With A/C, 17 terminals . . . . . B8S-14289-B 129.95
- 58-59 Without A/C, 11 terminals . . . . . B8S-14289-A 89.95
- 1960 With A/C, 17 terminals . . . . . COSF-14289-G 129.95
- 1960 Without A/C, 15 terminals . . . . . COSF-14289-C 109.95

## Oil Sending Unit Wire

- 61-63 14" long . . . . . C1SF-9A282-A 6.95

## Firewall to Headlight Junction Wires

- 1958 . . . . . B8S-14290-A 149.95
- 1959 . . . . . B9SF-14290-A 149.95
- 1960 . . . . . COSF-14290-A 149.95

## Overdrive Relay Wires

- 1958 To ignition coil wire, 54" long . . . . . FEV-14381-A 6.95
- 1958 To ignition switch wire, 30" long . . . . . FEV-14396-A 4.95

## Horn Feed Wire (2 required)

- 1959 22" long PCV wire . . . . . FFV-14440-A 5.95

## Power Seat Wires

- 58-59 Seat switch wire, 12 terminals . . . . . FEV-14642-A 39.95
- 58-60 Regulator relay feed wire, 106" long . B8S-14643-A 8.95
- 58-60 Circuit breaker to starter relay wire, 52" long . . . . . B8S-14682-A 19.95
- 1960 Circuit breaker to seat solenoid wire, 52" long . . . . . FEV-14682-C 7.95

## Headlight Sockets & Wires (2 required)

- 1959 14" long . . . . . B9S-13076-A 29.95
- 60-63 23" long . . . . . B9AF-13076-A 26.95

## Parking Light Socket & Wire (2 required)

- 58-60 27" long . . . . . FEV-13234-A 24.95

## Dash Wiring Harnesses

- 1958 . . . . . B8S-14401-A 549.95
- 1959 . . . . . B9SZ-14401-A 549.95
- 1960 . . . . . COSZ-14401-A 559.95



## Body Wiring Harnesses



58-60	With turn signal wires, 24 terminals, coupe.....	COSF-14405-D	159.95
58-59	36 terminals, without brake relay Convertible .....	B9SF-14405-B	319.95

## Door Wiring Shields

58-60	Door wiring shield, right .....	B5S-4020768-A	36.95
58-60	Door wiring shield, left.....	B5S-4020769-A	36.95

## Power Window Wires

58-59	Regulator relay to circuit breaker, 66" long .....	B8S-14678-A	19.95
58-59	Regulator relay to starter solenoid, 55" long .....	FEY-14679-A	5.95

## Electric Clock Wires

58-60	Feed wire, with fuse holder, 10" long .	FEV-15026-D	19.95
58-60	Light socket, 8" long .....	FEG-15026-B	12.95

## Wire Looms (as required)



ALL	1/4" ID, black flexible cloth .....	V14597B	0.50 foot
ALL	5/16" ID, black flexible cloth .....	V14597C	0.60 foot
ALL	1/2" ID, black flexible cloth .....	V14597D	0.70 foot

## Wire Loom Retainers



ALL	Wiring harness clip, plastic (as required).	376914-S	0.95
ALL	Wiring harness clip, plastic (as required).	382184-S	2.95
58-60	Firewall grommet retainer .....	8A-14608	9.95

## Wiring Hardware

61-63	Engine compartment wire loom fastener set, 8 round black plastic clamps & 8 hex washer-head screws, for left side of engine compartment . . .	2HK48A	8.95 set
64-66	Engine compartment wire loom fastener set, 16 round black plastic clamps & 16 hex washer-head screws .....	2HK48B	14.95 set

## Glass Tube Fuses

Back in the day, we all carried "spare" fuses in our glovebox. Nowadays, most stores don't even carry glass tube fuses. Here at MAC's we know you might need them, so we carry them for your convenience. Call us today & place your order so you have spares, "just in case." We suggest you look in your owner's manual for the exact application for each fuse & order accordingly.

58-62	AGC-15, set of 5 pieces .....	A2AZ-14526-A	2.95 set
58-66	SFE-14, set of 5 pieces .....	AOAZ-14526-A	2.95 set
1959	AGA-2, set of 5 pieces .....	51A-14526-A	3.95 set
1964	AGW-15, set of 5 pieces .....	C4SZ-14526-B	2.95 set
64-66	SFE-20, set of 5 pieces .....	AOAZ-14526-B	2.95 set

# DASH

Does your lighter light? How about that turn signal lever...does it function properly & then cancel itself when the steering wheel is turned? How do those ashtrays look? Hmmm. Do you have to lift up on the shift lever to activate the neutral safety switch?

Never fear, MAC's is here, with lots of switches, bezels, knobs, levers, speedometer parts, grommets & more for your Thunderbird. That big

beautiful Thunderbird dash just sits there, right in front of your face, every time you get behind the wheel.

So brighten the look & restore the proper function of the many gauges, switches, knobs & relays in your dash with brand new quality parts & enjoy your time behind the wheel just a little bit more!

## Dash Pads



These dash pads are oversized, which require additional shipping charges & also require an additional handling charge.

**CUSTOMER NOTE:** Radio opening is covered. When cutting radio or speaker opening, avoid removing too much vinyl material. Always leave enough material to tuck under.

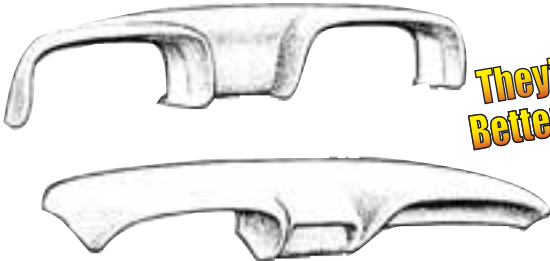

**They're Back & Better Than Ever!**

These new dash pads are made using the original Ford tooling, featuring vacuum-formed vinyl filled with urethane foam, just like the originals! Dash Hardware on page 240.

58-60	Black .....	COSB-6304290-B	399.95
61-62	Black, before 4-1-62 .....	C1SZ-6304290-B	399.95

## Vinyl Protectant

Keep that dash pad looking brand new for years to come. Protect your new dash pad from harmful UV rays with our Raggtopp™ vinyl protectant. It's so easy to use; just spray it on, wipe it dry & you're done. It is specially formulated to repel dust, dirt & grease, plus it contains no silicones so it's not slippery to the touch when it dries. Packaged in a convenient 16 oz. pump spray bottle.



ALL	For interior/exterior vinyl .....	RSP11415	16.95
-----	-----------------------------------	----------	-------

## Dash Warning Light Inserts



1960	"OIL," red lens with chromed plastic surround, fits into dash bezel B8S-10844-A. ....	COSZ-10823-OIL	21.95
1960	"GEN," red lens with chromed plastic surround, fits into dash bezel B8S-10844-A. ....	COSZ-10823-GEN	21.95













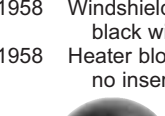
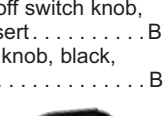
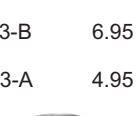
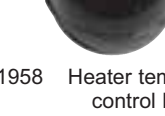
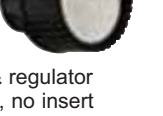

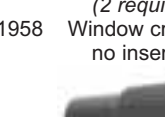
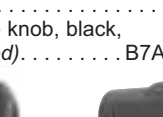
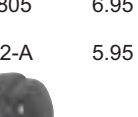
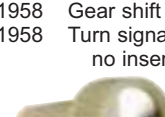
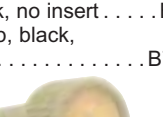
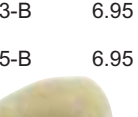
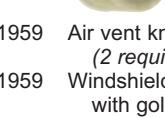
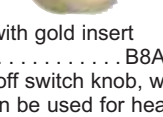
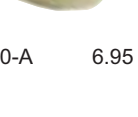
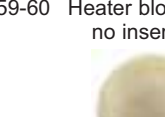
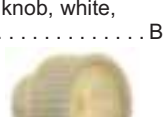
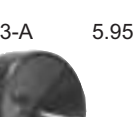
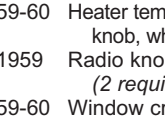
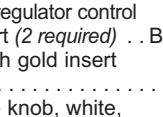
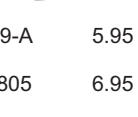

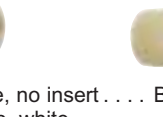
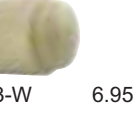

Dash Bezels

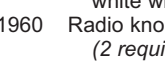
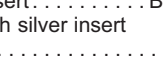
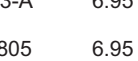
-    
58-60 For oil & generator "idiot" lights in dash, stainless steel (2 required) . . . . . B8S-10844-A 15.95
-    
58-63 Dash bezel, chrome, for wipers, ignition or lights (3 required) . . . . . FAA-10853-A 11.95
-    
1960 Headlight switch, chrome with clear letters. . . . . COSB-10852-LC 22.95
-    
1960 Headlight switch, chrome with green letters. . . . . COSB-10852-LG 22.95
-    
1960 Wiper switch, chrome with clear letters . . . . . COSB-10852-WC 22.95
-    
1960 Wiper switch, chrome with green letters . . . . . COSB-10852-WG 22.95
-    
1960 Ignition switch, chrome with clear letters. . . . . COSB-11580-C 22.95
-    
1960 Ignition switch, chrome with green letters. . . . . COSB-11580-G 22.95
-    
1960 Cigar lighter, chrome with clear letters . . . . . COSB-15052-C 22.95
-    
1960 Cigar lighter, chrome with green letters. . . . . COSB-15052-G 22.95
-    
61-63 Ignition switch bezel, "ACC, OFF, ON, START" for ignition switch . . . . . C3AZ-11584-A 10.95
-    
64-66 Round chrome replacements for the 4 chrome gauge "pods" below the speedometer, with retaining tabs (4 required). . . . . C4SZ-9A283-A 32.95
-   
58-60 Bezel retainer nut, for ignition switch. B6A-11585-A 14.95

Dash Knobs

-     
1958 Air vent knob, black with silver insert (2 required) . . . . . B7A-7001890-B 6.95
-     
1958 Windshield wiper on-off switch knob, black with silver insert. . . . . B7A-17513-B 6.95
-     
1958 Heater blower switch knob, black, no insert . . . . . B7A-18513-A 4.95
-     
1958 Heater temperature & regulator control knob, black, no insert (2 required) . . . . . B7A-18519-A 5.95
-     
1958 Radio knob, black with silver insert (2 required) . . . . . B7A-18805 6.95
-     
1958 Window crank handle knob, black, no insert (4 required). . . . . B7A-7023352-A 5.95
-     
1958 Gear shift knob, black, no insert . . . . . B7A-7213-B 6.95
-     
1958 Turn signal lever knob, black, no insert . . . . . B7A-13305-B 6.95
-     
1959 Air vent knob, white with gold insert (2 required) . . . . . B8A-7001890-A 6.95
-     
1959 Windshield wiper on-off switch knob, white with gold insert, can be used for headlight switch knob by using your old shaft & removing the old knob. . . . . B8A-17513-A 6.95
-     
59-60 Heater blower switch knob, white, no insert . . . . . B8A-18513-A 5.95
-     
59-60 Heater temperature & regulator control knob, white, no insert (2 required) . . . . . B8A-18519-A 5.95
-     
1959 Radio knob, white with gold insert (2 required) . . . . . B8A-18805 6.95
-     
59-60 Window crank handle knob, white, no insert (4 required). . . . . B8A-7023352-A 5.95
-     
59-60 Gear shift knob, white, no insert . . . . . B8A-7213-W 6.95
-     
59-60 Turn signal lever knob, white, no insert . . . . . B8A-13305-W 5.95
-     
1960 Air vent knob, white with silver insert (2 required) . . . . . B9A-6301890-A 6.95
-     
1960 Windshield wiper on-off switch knob, white with silver insert. . . . . B9A-17513-A 6.95
-     
1960 Radio knob, white with silver insert (2 required) . . . . . B9A-18805 6.95



### Dash & Console Aluminum Trim

All that aluminum trim was beautiful when your Bird left Detroit. Now though, time has taken its toll with scratches, dents & discoloration. We are pleased to offer new reproductions of these trim items in all their original glory! Console hardware on page 240 Place your order today! Sorry, no woodgrained or tinted versions are available.

61-62	Console aluminum trim . . . . .	C2SZ-6304567-E	84.95
61-63	Dash aluminum, left . . . . .	C1SB-63044B07-B	50.95
61-63	Dash aluminum, center, with A/C . . . . .	C1SZ-63044B08-A	56.95
61-63	Dash aluminum, right, with A/C . . . . .	C1SZ-63044B06-A	106.95
61-63	Dash aluminum, right, without A/C . . . . .	C1SB-63044B06-A	140.95
61-63	Console ashtray aluminum trim . . . . .	C1SZ-63048A14-D	30.95
1963	Console aluminum trim, without power windows . . . . .	C2SZ-6304567-E	84.95
1963	Console aluminum trim, with power windows . . . . .	C3SZ-6304567	84.95

### Console Moulding Clip (as required)

61-66	<b>NEW</b> . . . . .	C1SB-63044B26-A	0.95
-------	----------------------	-----------------	------

### Dash Emblem



61-63	"Thunderbird" . . . . .	C1SB-6304460-A	28.95
-------	-------------------------	----------------	-------

### Constant Voltage Regulators



Located on the back of the instrument cluster, this unit controls the voltage going to your gauges. If all of your gauges read the maximum setting then this is definitely the culprit!



60-66	Constant voltage regulator . . . . .	B9MZ-10804-C	24.95
-------	--------------------------------------	--------------	-------

### Speedometer Cables



58-60	Housing & core (shown) . . . . .	C5DZ-17260-A	25.95
61-63	Housing & core . . . . .	C1SZ-17260-AR	49.95
64-65	Housing & core, without cruise control, before 11-13-64 . . . . .	C4SZ-17260-AR	49.95
64-65	Housing & core, with cruise control, upper . . . . .	C4SZ-17260-GR	49.95
64-65	Housing & core, with cruise control, lower . . . . .	C4SZ-17260-FR	49.95
65-66	Housing & core, without cruise control, from 11-13-64 . . . . .	C5SZ-17260-AR	49.95
1966	Housing & core, with cruise control, lower . . . . .	C3DZ-17260-F	19.95
1966	Housing & core, with cruise control, upper . . . . .	C6SZ-17260-BR	29.95

### Speedometer Cable Lubricant



61-66	Graphite-in-oil formulated especially for long-life, all-temperature lubrication of speedometer cable . . . . .	A17260L	2.50
-------	-----------------------------------------------------------------------------------------------------------------	---------	------

### Speedometer Driven Gears, at End of Cable



Always match up the number of teeth & the color with your original gear. Usage varied during the year. Also, you will only get an absolutely correct speedometer reading if you are using the correct (original diameter) tire size, engine & transmission.



58-63	18 teeth, white, type 3a. . . . .	COAA-17271-K	22.95
64-66	16 teeth, wine, type 3a, <b>Genuine Ford</b> . . . . .	CODZ-17271-A	9.95
64-66	17 teeth, white, type 3a. . . . .	C3DZ-17271-C	9.95
65-66	18 teeth, gold or yellow, type 3a, <b>Genuine Ford</b> (not shown) . . . . .	CODD-17271-B	9.95



65-66	19 teeth, natural, type 3a, <b>Genuine Ford</b> . . . . .	CODZ-17271-B	11.95
65-66	20 teeth, black, type 3a, <b>Genuine Ford</b> . . . . .	C1DZ-17271-A	11.95

### Seal

58-66	"O" ring type, at transmission . . . . .	1A-17298	2.95
-------	------------------------------------------	----------	------

### Retainer



58-66	"C" shaped, <b>Genuine Ford</b> . . . . .	C1DZ-17292-A	0.95
-------	-------------------------------------------	--------------	------

### Speedometer Drive Gears, Inside Transmission

1965	Steel, 7 teeth, <b>limited availability</b> . . . . .	C3OZ-17285-C	39.95
1965	Nylon, 8 teeth, brown, <b>Genuine Ford</b> . . . . .	C8OZ-17285-B	25.95

### Sports Roadster Grab Bar

62-63	Chrome with beige vinyl . . . . .	C2SZ-76045B22-BGE	195.95
-------	-----------------------------------	-------------------	--------

### Dash Pad Parts

62-63	Ends, "ears," black vinyl clad metal . . . . .	C2SZ-63044B76-PR	31.95 pair
62-63	End plates, black vinyl clad metal . . . . .	C2SZ-63045A64-PR	49.95 pair

### Dash Bezel Seal Set

58-59	5 pieces. . . . .	FAA-10868-BST	14.95 set
-------	-------------------	---------------	-----------

### Ignition Switches



58-60	Does not include bezel, lock cylinder or keys. . . . .	B5A-11572-A	24.95
61-64	Does not include bezel, lock cylinder or keys. . . . .	C3AZ-11572-A	16.95
65-66	Does not include bezel, lock cylinder or keys. . . . .	C5AZ-11572-B	23.95



### Ignition Switch Repair Plug & Wires

*Includes the plug for the back of the ignition switch & wires to splice into harness.*

61-63	.....C1SZ-11A572-A	24.95
64-66	..... CODZ-11A572-A	24.95

### Ignition Switch Lock Cylinder & Keys

*MAC's carries ignition & door lock sets so you can have matching keys, see Door Parts, pg 227.*



58-60	2 keys, fits into B5A-11572-A, listed on bottom of previous page . . . . B9A-11582-A	11.95
58-60	<b>NEW</b> Ignition switch lock cylinder & 2 reproduction Ford script keys, fits into B5A-11572-A, listed to the left . . B9A-11582-AF	18.95



61-64	2 keys, fits into C3AZ-11572-A, listed on bottom of previous page . . . . C3AZ-11582-A	13.95
65-66	2 keys, fits into C5AZ-11572-B, listed on bottom of previous page . . . . C9AZ-11582-A	8.95

### Windshield Wiper Knobs & Shafts

1958	Knob & shaft . . . . . B8S-17513	8.95
1959	Knob & shaft . . . . . B9A-17513	9.95
1960	Knob & shaft . . . . . COSZ-17513	8.95

### Windshield Washer Switch Housing

*This heavier plastic housing replaces the thin-walled original when it becomes cracked & your washers no longer work.*

64-66	.....C4SZ-17A625-HSG	11.95
-------	----------------------	-------

### Headlight Switches



58-60	Headlight switch, <b>except</b> 1960 convertible, holds 2 fuses: the upper is for the dome light & the lower is for the turn signals . . . . B9AF-11654-A	80.95
61-63	Headlight switch . . . . . C3SZ-11654-A	39.95
1964	Headlight switch (not shown) . . . . C4VY-11654-A	69.95
65-66	Headlight switch . . . . . C5SZ-11654-CR	67.95

### Headlight Switch Knobs & Shafts



1958	Black with silver insert. . . . . B8S-11661-A	8.95
1959	White with gold insert . . . . . B9SF-11661-A	9.95
1960	White with silver insert (shown) . . COSF-11661-A	8.95

### Dimmer Switches



58-60	Headlight dimmer switch . . . . . B7AZ-13A024-A	17.95
61-66	Headlight dimmer switch . . . . . COTZ-13A024-A	8.95

58-66	Rubber cover, a copy of an original accessory . . . . . C5ZZ-13533-A	4.95
-------	----------------------------------------------------------------------	------

### Turn Signal Switch Pawl & Spring



58-63	Turn signal switch pawl. . . . . 1M-13309-A	6.95
58-60	Turn signal switch pawl spring . . . . 1M-13316-A	1.95

### Turn Signal Switch Canceling Cams



58-62	..... FAB-13318-A	15.95
64-66	..... C4SZ-13318-A	14.95

### Turn Signal Switch

61-63	.....C2SZ-13341-A	50.95
-------	-------------------	-------

### Turn Signal Switch to Pawl Spring



58-60	..... 1M-13343-A	3.95
-------	------------------	------

### Turn & Emergency Signal Flashers

63-66	Turn signal flasher. . . . . C5AZ-13350-B	10.95
-------	-------------------------------------------	-------



65-66	Emergency flasher . . . . . C6AZ-13350-A	4.95
-------	------------------------------------------	------





**Turn Signal Levers**

- 1958 Chrome shaft with black knob . . . . . B8S-13305-A 16.95
- 1959 Chrome shaft with white knob . . . . . B9SF-13305-A 16.95
- 1960 Chrome shaft with white knob . . . . . COSF-13305-A 16.95



- 61-62 Chrome, before 1-18-62 . . . . . C1SZ-13310-A 15.95
- 62-66 Chrome, from 1-18-62. . . . . C2SZ-13310-A 15.95



- 63-66 Chrome shaft with black knob, from 1-18-62, Ford service replacement . . . . . D3TZ-13305-B 16.95

**Turn Signal Sequencer**



*One of the neatest ideas Ford had to make the Thunderbird distinctive was the sequential turn signal. The problem was the sequencer failed far too often & far too soon. Don't fret, MAC's has the cure—our solid-state replacement sequencer. Get those tail lights blinking 1-2-3 like they are supposed to ... today!*

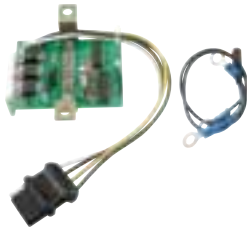

- 65-66 Electronic sequencer kit, modern solid state replacement unit to replace your unrepairable mechanical original, complete with detailed instructions . . . . . C6SZ-13350-KT 135.95 kit

**Emergency Flasher Relays**

*These relays are found in the trunk next to the sequencer package only in 1966 & only in the Town Coupe & Landau models with an overhead console.*

- 1966 4 wire plug . . . . . C6SZ-10C838-A 67.95
- 1966 3 wire plug . . . . . C6SZ-10C838-B 67.95

**Stop Light Switches**



- 58-64 Mounts on the master cylinder . . . . . C1AZ-13480-A 7.95
- 65-66 Mounts under the dash on the brake pedal arm . . . . . C5SZ-13480-C 39.95

**Stop Light Relays**



- 1964 . . . . . C3VY-14512-D 55.95
- 65-66 Before 11-17-65, mounts in the trunk as part of the sequential package . . . . . C5SZ-13482-AR 54.95
- 1966 After 11-17-65, mounts in the trunk as part of the sequential package (not shown) . . . . . C7SZ-13482-B 55.95

**Courtesy Light Switch & Actuator (2 required) \_\_\_\_\_**



- 58-66 On door jamb . . . . . 8M-13713 6.95
- 64-66 Switch actuator, wedge-shaped, mounts on door . . . . . C4SZ-13A786-C 8.95

**Cigar Lighter Parts**

- 1958 Knob, black with silver insert . . . . . B8S-15052 6.95
- 1959 Knob, white with gold insert . . . . . B9SF-15052 5.95
- 1960 Knob, white with silver insert . . . . . COSF-15052 6.95
- 1960 Knob & element, chrome with clear letters . . . . . COSF-15052-C 36.95
- 1960 Knob & element, chrome with green letters . . . . . COSF-15052-G 36.95
- 58-59 Shaft . . . . . B8S-15052-SHAFT 2.95
- 1960 Shaft . . . . . COSF-15052-SHAFT 2.95
- 58-60 Washer, chrome . . . . . B8S-15052-WASHER 3.95



- 58-66 Element, Ford service replacement . . . . . D3AZ-15054-A 10.95
- 58-66 Socket . . . . . B6C-15055-A 16.95
- 58-60 Outer chrome bezel . . . . . COSB-15059 22.95

**Ashtray & Lighter Hardware**

- 61-63 Console ashtray screw set, 4 oval-head Phillips screws . . . . . 2HK45K 2.95 set
- 61-63 Console ashtray cover handle screw set, 2 pan-head Phillips screws . . . . . 2HK45L 2.95 set
- 64-66 Console cigar lighter & ashtray case hardware kit, 4 slotted hex washer-head screws, 2 oval-head Phillips screws & 4 external-tooth lock-washers . . . . . 2HK45V 2.95 kit
- 64-66 Rear console ashtray retainer screw set, 3 pan-head Phillips screws . . . . . 2HK45Y 2.95 set

**Glove Box Parts**

*Consider yourself lucky if you have any glove box liner at all. They were made of cardboard & didn't react well when we jammed sunglasses, a couple of pens, some pencils (because the pens never worked), air pressure gauges, matches, the owners manual & about 10 maps in there. We have brand new glove box liners, all with stainless steel clips already installed. Order yours today!*



- 58-60 Liner, the installation clips are installed. . . . . B8S-6306010-A 16.95
- 61-63 Liner, ABS plastic replacement . . . . . C2SZ-6306010 67.95
- 1958 Lock bezel, black plastic (not shown) . . . . . B8S-6306081-BZL 14.95

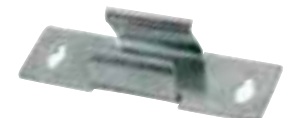

- 58-60 Glove box door bumpers, rubber . . . . . 359422-PR 2.95 pair
- 59-60 Lock bezel, white plastic . . . . . COSB-6306081-BZL 14.95
- 61-64 Catch, for the latch . . . . . C2SZ-7606167-C 1.95



## Firewall Covers

Is your firewall cover leaving clumps of itself on your floor? It's about time you took the next step. Made of tough ABS plastic & ready to install, with no cutting required our firewall covers will look very close to original & do a far better job of insulating you from heat & noise.

- 58-60 **NEW OS** No holes to drill, 15 clips required (48-7001670-A listed below) . . . B8S-6301670-B 190.95
- 61-63 **NEW OS** Backed with fiber insulation, 13 clips required (48-7001670-A listed below) . . . C1SZ-6301670-B 210.95
- 64-66 **NEW OS** Rubber with fiber insulation, 6 clips required (48-7001670-A listed below) . . . C4SZ-6301670-B 210.95

### Firewall Cover Clip (as required)



- 58-66 Holds firewall cover to firewall, 1-1/8" overall length . . . . . 48-7001670-A 2.75
- 58-66 **NEW** Firewall cover clip, plastic replacement type, 7/8" reach with a 1-1/8" overall length . . . . . 390018-S 0.95

## Firewall Grommets, Retainer & Seal



- 58-60 Grommet, mounts on left side of firewall . . . . . B8S-14603 3.95
- 61-64 Grommet, for A/C hoses at firewall . . . . . COAF-19B588-A 5.95
- 65-66 Grommet, for A/C hoses at firewall (not shown) . . . . . C5SZ-19B588 9.95
- 58-60 Retainer . . . . . 8A-14608 9.95
- 64-66 Heater core tubes at firewall seal, without A/C (not shown) . . . . . C4SZ-18596 3.95

## Bulk Insulation

Insulation technology has made great advances in the past 30 years & we stock one of the latest developments. Rated at R18 (good to 700°) this would reflect much more heat than what is in your car now. Simply cut to size & attach with our super trim adhesive (RSP79).



- ALL 48" x 72" x 5/16" thick, can be used on the firewall, behind the kick panels & in hardtops under the package tray & behind the seat (as required) . . . . . V700770X 32.00



- ALL Super trim adhesive, 3M brand, the best adhesive for securing headliners, vinyl tops & hood insulation pads, 19 oz. spray can . . . . . RSP79 \* 17.95

**\*HAZARDOUS MATERIAL** - Can only be shipped by ground within the U.S. because of government safety regulations.

## Cowl Vent Drain Tubes

1964 was a transition year, meaning it could have either length tube originally. Compare your 1964 cowl vent tube to the pictures shown before placing your order. Cowl vent hardware on page 242.



- 61-64 Cowl vent drain tubes, rubber. C1SZ-6302207-PR 31.95 pair
- 64-66 Cowl vent drain tubes, rubber, use C1SZ-8287-PR below to install . . . . . C4SZ-6302207-PR 31.95 pair
- 61-66 Cowl vent drain tube clamp, like original with "Wittek Chicago" stamped into it . . . . . C1SZ-8287-PR 22.95 pair
- 64-66 Bracket for cowl vent drain tubes . . . C4SZ-16026 31.95 pair

## Cowl to Fender Reinforcement & Bracket

- 64-66 Cowl to fender reinforcement bracket, includes backing plate & bolt, convertible . . . . . C4SZ-16D026-A 31.95 pair

# Hood



## Hood Insulation Pad Sets

Some early production 1965 Thunderbirds used the 3-piece 1964 style hood pad set, check yours before ordering.



- 58-60 Die-cut, 6 pieces, originally did not have hood pads . . . . . COSB-16738-ST 47.95 set
- 61-63 Die-cut fiberglass, 5 pieces . . . . . C1SZ-16738-ST 43.95 set
- 64-65 Die-cut fiberglass, 3 pieces, verify number of pieces . . . . . C4SZ-16738-ST 43.95 set
- 1965 Die-cut fiberglass, 5 pieces . . . . . C5SZ-16738-ST 43.95 set
- 1966 Die-cut fiberglass, 5 pieces . . . . . C6SZ-16738-ST 43.95 set



- 61-66 Super trim adhesive, 19 oz. spray can . . . RSP79 \* 17.95

\* **HAZARDOUS MATERIAL** can only be shipped by ground/ surface within the U.S. because of government regulations.

## Hood Bumpers

If your hood isn't aligned correctly with the fenders it could be as simple as having bad, worn out hood bumpers. Refresh those hood bumpers with some of our "correct" reproductions today!

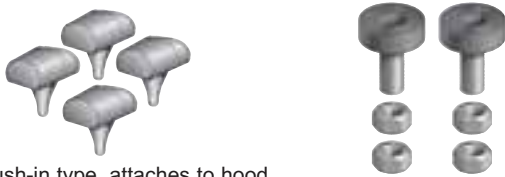

- 58-60 Push-in type, attaches to hood, set of 4 . . . . . B7A-16758-ST 8.95 set
- 58-60 Screw-in stud with rubber tip, attaches to cowl . . . . . B5A-16769-PR 8.95 pair
- 58-60 Screw-in type, attaches to the center of the cowl (not shown) . . . . . 358939-S 6.95 pair

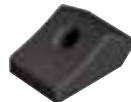

- 61-64 Screw-in stud with rubber tip, attaches to radiator support, 3/8"-24, concours quality (2 required) . . . . . C4SZ-16763-A 8.95
- 62-66 Screw-in type, wedge shape, attaches to fender (4 required) . . C2SZ-16763-A 2.95
- 1965 Screw-in stud with rubber tip, attaches to radiator support, concours quality (2 required) . . . C5SZ-16763-A 5.95



- 65-66 Screw-in stud with rubber tip, attaches to radiator support, economy version . . . . . C5ZZ-16763-PR 4.95 pair
- 1966 Screw-in stud with rubber tip, attaches to radiator support, 3/8"-24, concours quality, gold cadmium plated stud (2 required) . . . . . C5ZZ-16763-B 3.95

## Hood Hinges & Spring (2 required)



When you try to raise your hood & it goes up at an angle you have worn out hood hinges. The pivot points get elongated & although the hinge still functions, it's an accident waiting to happen. Don't take a chance, call today!



- 61-66 Hood hinge, yellow cadmium plated like original, right . . . . . C1SZ-16796-R 101.95
- 61-66 Hood hinge, yellow cadmium plated like original, left (shown) . . . . . C1SZ-16797-L 101.95

### BUY a PAIR & SAVE

- 61-66 Hood hinge, yellow cadmium plated like original, right & left . . . . . C1SZ-16796-PR 198.95 pair
- 61-66 Hood hinge spring . . . . . C1SZ-16789-A 15.95



- All White grease, water resistant, use on speedometer cables, hinges, latches, linkages & sliding parts, 12 oz. spray can . . . . . RSP19 \* 6.95

\* **HAZARDOUS MATERIAL** can only be shipped by ground/ surface within the U.S. because of government regulations.

## Hood Release Handle



- 58-60 Handle . . . . . B8S-16916-A 16.95

## Hood Lock Cam Bumper (2 required)



- 58-60 Rubber . . . . . B7A-16993-A 1.95

See all of our hood hardware kits on page 242





The windshield wiper system on any car works pretty hard during its lifetime, unless you live in an arid climate. Even then, sunlight & heat are hard on various components. Over many years wiper motors drag the wipers & related transmission components back & forth across the big windshield in every kind of weather. Snow loads are especially hard on wiper motors. Wiper blades are subject to temperature extremes &

excessive wear. Wiper arms lose their spring tension, which allows the blade to skip over the glass, even with fresh rubber refills. Then there is the washer system, with the washer pump, hoses, connectors, brackets, reservoir bag & other components. Keep your vehicle's windshield wiper system in top working order.

**Call today for all the parts you need.**

### Wiper Motor Kit



Tired of trying to fix that old inefficient vacuum wiper motor? We have the answer—an electric conversion! While it's not "correct" for the show car, it's a much-needed improvement over the factory system. If you have ever been caught in the rain you'll know why we think this 12 volt motor is the set-up to have.



58-60 Includes the motor, necessary wiring & a new switch . . . . . B8S-17508-KT 269.95 kit

*If you want to use the original knob, you can. Just add our shaft extension & your original knob & bezel will work just fine.*

58-60 Wiper switch shaft extension, **except** intermittent wipers . . . . . 14010 20.95

*We can also help if you would like the convenience of intermittent wipers.*

58-60 Intermittent wiper switch . . . . . 14200 86.95  
58-60 Intermittent wiper switch shaft extension . . . 14012 20.95

### Wiper Arm



61-66 With chrome "smooth" end cap & stainless housing, left side only . C1SZ-17526-A 12.95

### Windshield Wiper Arm Clip (2 required)



1966 From 10-18-65 . . . . . C5ZZ-17531-A 3.95

### Wiper Blades (2 required)



58-60 13" long, black plastic replacement . . . . 17528-13 6.95  
61-62 16" long, black plastic replacement . . . . 17528-16 6.95  
63-66 18" long, black plastic replacement . . . . 17528-18 6.95

### Wiper Blades—Stainless Steel Type (2 required)

These wiper blades have stainless steel housings so they look more like original blades. Available in 13", 16" & 18" lengths, they are perfect for every year from 1958 thru 1966. Call us today & order some for your car.



58-60 **NEW** 13" long, stainless steel . . B8A-17528-13 16.95



61-62 **NEW** 16" long, stainless steel. . C1AZ-17528-16 16.95



63-66 **NEW** 18" long, stainless steel. . C1AZ-17528-18 17.95

### Wiper Blade Refills



61-62 16", universal replacement . . . . . 17593-16 6.95 pair  
63-66 18", universal replacement . . . . . 17593-18 6.95 pair

### Wiper Motor Hydraulic Hoses



Beginning in 1963, Ford installed a newly developed hydraulic windshield wiper system on the T-Bird. It used the high pressure of the power steering system to create a variable speed action. Another benefit of this was the "increased pressure" of the blades against the windshield. In the past these hoses were rarely found in good shape, MAC's has taken care of that by offering a beautiful reproduction to eliminate the need for that search, call us to order yours!

1963 From motor to steering gearbox . C3SZ-17B474-A 44.95  
1964 From motor to steering gearbox . C4SZ-17B474-A 44.95  
65-66 From motor to steering gearbox . C5SZ-17B474-A 44.95

### Return Tube Sets

1963 2 pieces, steel, from wiper motor to steering gear box . . . . . C3SZ-17B593-ST 30.95 set  
1963 2 pieces, stainless steel, from wiper motor to steering gearbox . . . . . C3SZ-17B593-STSS 36.95 set

### Windshield Washer Hose Tee & Nozzle



58-60 Windshield washer hose "tee". . . COAB-17A601-A 1.95  
64-66 Windshield washer nozzle. . . . . C4SZ-17A602 4.95 pair

# WIPERS



## Windshield Washer Bags

Washer bags & brackets are exact reproductions of the originals.



- 58-60 Red with white letters, with cap . . . . B8S-17618-A 34.95
- 1961 Red with white letters, with cap . . .C1SZ-17618-AR 39.95
- 62-63 Red with white letters, with cap . . . C1SZ-17618-A 34.95



- 64-65 Black with gold letters, with screw-on cap . . . . .C4SZ-17618-A 34.95
- 1966 Black with gold letters, with flip type cap . . . . .C6SZ-17618-A 34.95

## Windshield Washer Bag Hardware



- 58-60 Bracket, *limited availability* . . . . . BM-17651 19.95
- 61-63 Bracket . . . . .C1AB-17651-A 12.95
- 64-66 Bracket (not shown) . . . . .C1VB-17651-A 12.95

- 61-63 Hardware set, 2 hex washer head screws . 2HK57A 2.95 set
- 64-66 Hardware set, 2 hex washer head screws . 2HK57B 2.95 set

- 58-65 Cap, screw-on type . . . . . 17618-CAP 3.95



- 1966 Washer bag cap, flip type . . . . .17618-FLIPCAP 4.95

## Windshield Washer Switch Housing

This heavier plastic housing replaces thin-walled original when it becomes cracked & your washers no longer work.

- 64-66 . . . . .C4SZ-17A625-HSG 11.95

## Windshield Washer Pump

Reproduction of original that mounted on the fender apron.



- 61-66 . . . . . C1AZ-17664-C 33.95

## Windshield Wiper Pivot Shaft Nut



- 58-66 . . . . . 370695-S 7.95

## Inner Bezel Nut

- 58-60 For wiper control switch . . . . . B8S-17512-A 16.95

# WINDWING

## Vent Window Air Deflector (Windwing)

- 61-63 Plastic, does not include the mounting channel . . . . . C1SB-6322268-PR 24.95 pair

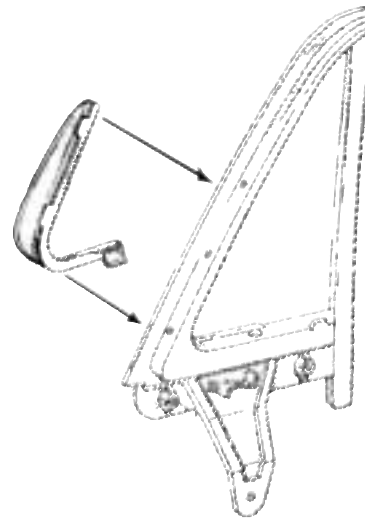



## Outside Rear-View Mirrors & Emblems

Outside rear-view mirrors have been subject to every bit of weather your car has ever experienced. The chrome gets dull & eventually it starts to pit. The glass gets cloudy & scratched over time. Take a look at one of our reproduction mirrors & you'll see a deep, lustrous chrome finish & the glass offers a perfect reflection. We have them in stock for a speedy delivery to your door, call us today!



58-59 Adjust-O-Ring, base gasket included (2 required) . . . . . B8S-17696-A 156.95

58-60 Assembly, round head, manual control, right or left, chrome, 2 hole base, no gasket—use B4A-17724-A or B5A-17724-R, listed on the next page (2 required) . . . . . B5AZ-17696-B 34.95



58-60 Assembly, round head, manual control, right or left, has "FoMoCo" script, chrome, 2 hole base, base gasket included (2 required) . . . . . B5A-18402-A 75.95

1960 Hooded with ribbed top & back, base gasket included (2 required) . B6A-18402-A 145.95



61-62 Assembly, round head, manual control, has "FoMoCo" script, right or left, chrome, base gasket included (2 required) . . . . . C1SZ-17696-BR 84.95

- 1963 Remote control, left . . . . . C3SZ-17696-A 145.95
- 1963 Manual control, right . . . . . C3SZ-17696-B 141.95
- 1964 Remote control, for early 64—does not use Thunderbird emblem, left . . . . . C4SZ-17696-AE 145.95
- 1964 Manual control, for early 64—does not use Thunderbird emblem, right . . . . . C4SZ-17696-BE 126.95



- 64-66 Without Thunderbird emblem, which is listed below, left, base gasket & remote control cable, without remote control knob & bezel, chrome . . . . . C4SZ-17696-CR 163.95
- 64-66 Without Thunderbird emblem, which is listed below, right, manual control, chrome, base gasket included . . . . . C4SZ-17696-DR 139.95

## Outside Rear-View Mirror Parts

### Outside Rear-View Emblem



- 64-66 Thunderbird, 1 emblem per mirror, chrome (2 required) . . . . . C4SZ-17B686-AR 23.95

### Bezel & Nut

- 61-63 Nut, for remote control mirror, mounts on door trim panel . . . . C2VY-17B719-A 13.95



- 64-66 Nut, for remote control mirror, mounts on door trim panel . . . C4SZ-17B732-A 10.95
- 64-66 Bezel, for remote control mirror, mounts on door trim panel . . . . C4SZ-17530-A 12.95

### Toggle Control



- 63-66 For remote control mirror, mounts on door trim panel . . . C2VY-17B718-A 40.95

### Mounting Plate



- 64-66 Right or left (2 required) . . . . . C4SZ-17A717-A 9.95

### Set Screw

- 64-66 Stainless steel (2 required) . . . . . 378213-S 2.95
- 1963 Remote rear-view mirror to body screw set, 2 oval-head Phillips screws, 1 set per mirror (2 sets required) . . . . 2HK74N 2.95 set
- 1964 Outside rear-view mirror screw set, 2 oval-head Phillips screws, early 1964 only, 1 set per mirror . . . . 2HK74P 2.95 set
- 64-66 Outside rear-view mirror screw set, 2 pan-head Phillips screws, left hand mirror only, from mid-1964 . . . . . 2HK74R 2.95 set





## Outside Rear-View Mirror

### Base Pads & Gaskets (2 required)

#### Base Gasket

58-59 Molded rubber, for B8S-17696-A mirror . . . . . B8S-17724-A 6.95



58-60 Paper, fits B5AZ-17696-B mirror . . . . . B4A-17724-A 1.95

1960 Molded rubber, fits B6A-18402-A mirror . . . . . B6A-17724-A 6.95

#### Base Pad



58-60 Molded rubber, fits B5AZ-17696-B mirror . . . . . B5A-17724-R 5.95

61-62 Molded rubber, fits C1SZ-17696-BR mirror . . . . . C1SZ-17724 5.95



64-66 Molded rubber, right or left . . . . . C4SZ-17724-C 5.95

## Inside Rear-View Mirrors



*I know you think your mirror looks ok, but do you know how good our mirrors look? Examine the polished back & the perfect reflection of the glass & you'll be convinced that our mirror would look great in your interior. Perfect reflections along with "correct" details make these the nicest mirrors on the market!*



58-59 Assembly, includes stem, requires bracket B8S-17702-A listed to the right. COAB-17700-E 45.95

1960 "Day-Night" rear view mirror, twist type (not shown) . . . . . COSZ-17700 81.95



61-64 "Day-Night" rear-view mirror assembly, see-saw type, mounting arm & bracket listed to the right. . . . . C1SZ-17700-D 47.95



65-66 "Day-Night" rear-view mirror assembly, twist type, mounting arm & bracket listed to the right . . . . . C4SZ-17700-A 47.95

## Inside Rear-View Mirror Arms & Brackets

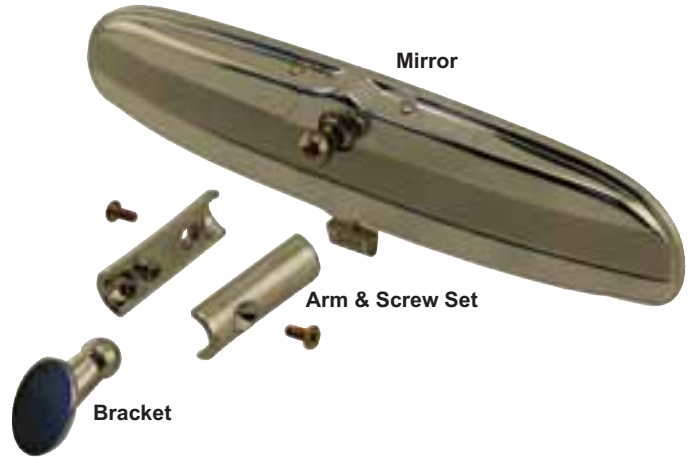

61-66 Arm & screw set, mounts to bracket on windshield, correct satin finish, includes 2-piece arm & 2 screws . . . . . C2SZ-17690-S 19.95

61-66 Arm & screw set, mounts to bracket on windshield, chrome finish, includes 2-piece arm & 2 screws . . . . . C2SZ-17690-FR 16.95 set



58-59 Bracket, screws onto windshield header, chrome . . . . . B8S-17702-A 19.95



61-66 Bracket, glues onto windshield, chrome . . . . . C1SZ-17698-D 9.95



ALL Bracket adhesive, glues mounting bracket to glass, .02 oz. . . . . 11067-2 2.95



**Body to Bumper Seals & Retainer**



- 58-60 Seals, front . . . . . B8SZ-16304-PR 14.95 pair
- 58-60 Retainer, use with body to bumper seals listed above (2 required) . . B8SZ-16311-A 9.95



- 61-63 **Save** Seal set, includes 2 front bumper to fender seals & 2 rear bumper "Q" seals . . . . . C1SZ-16304-ST 230.95 set
- 61-63 Seals, front . . . . . C1SZ-16304-FRT 108.95 pair
- 61-63 Seals, rear . . . . . C1SZ-17A970-PR 129.95 pair

**Front Bumper Guard Spacer (2 required)**

- 1966 Rubber . . . . . C6SZ-17120-A 16.95

**Bumper Bolt (as required)**

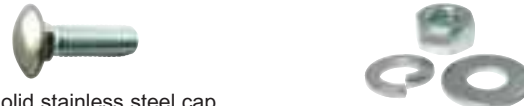

- 58-66 Solid stainless steel cap, 7/16"-14 x 1-3/4" . . . . . B9A-17758-A 2.95
- 58-66 **NEW** Nut & 2 washers for bumper bolt B9A-17758-A, listed above. B9A-17758-NW 0.95 set

**Rear License Plate Light Parts**



- 64-66 Rear license plate light lens . . . . . C4AZ-13564-A 8.95



- 64-66 Housing . . . . . C4AZ-13560-A 19.95
- 64-66 Assembly . . . . . C4AZ-13550-A 29.95
- 64-66 Rear license plate holder screw & nut set, 2 slotted pan-head screws & 2 plastic license plate nuts . . . . . 2HK13A 3.95 set
- 64-66 Rear license plate light bolt set, 2 black oxide finish, faceted-flange-head bolts . . . . . 2HK13B 2.95 set



- 1966 Door . . . . . C5OZ-13566-B 4.95

**Rear License Plate Lens Gasket**



- 64-66 . . . . . C4AZ-13568-A 0.95

**License Plate Bumpers (as required)**



- 58-60 Used front or rear (shown) . . . . . B8S-13398-A 2.95
- 61-63 2 are used on the front & 1 on the rear . 353483-S 1.95
- 64-65 **NEW** Used on the front (shown) . . . . . 375838-S 3.95 pair

**Front License Plate Brackets**

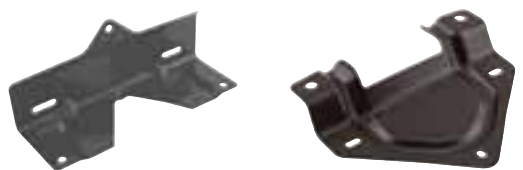

- 58-60 . . . . . B8S-17736-A 23.95
- 61-63 . . . . . C1SB-17A385-A 22.95
- 64-65 Before 4-13-64, will fit all '64 & '65. C4SZ-17A385-B 29.95



- 1966 **NEW** Front license plate bracket . . . . . C6SZ-17A385-A 19.95

**License Plate Bracket Hardware**

- 61-63 2 hex head bolts & 2 flat washers. . . . . 2HK13C 2.95 set
- 64-65 2 black oxide finish, faceted-flange-head bolts, 2 hex-head bolts with captive flat washers & 4 black oxide finish faceted-flange lock nuts . . . . . 2HK13D 5.95 kit
- 1966 Front license plate bracket bolt set, 2 hex head bolts with captive flat washers, black oxide finish. . . . . 2HK13E 2.95 set

**Rear Bumper Splash Panels**

- 64-66 Metal, convertible . . . . . C4SZ-16D556-PR 49.95 pair
- 64-66 Rubber, coupe . . . . . C4SZ-63403C40 14.95 pair

**Rear Bumper Stone Deflector Seals**

- 58-60 . . . . . B8S-17832-PR 19.95 pair

**Rear Bumper Bullet Filler & Mounting Washer**

- 58-60 Bullet filler . . . . . B8S-17788-PR 33.95 pair
- 64-66 Mounting washer (as required) . . C4SZ-17B898-A 0.95

**Lower Back Panel Splash Shields**

- 61-63 To rear bumper, coupe or convertible, rubber . . . . . C1SZ-63403B34-PR 14.95 pair

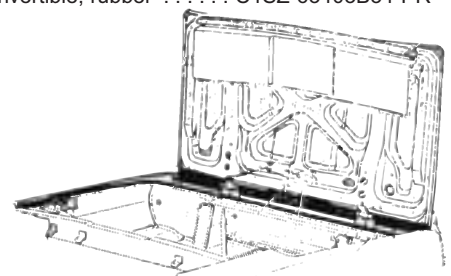

- 64-66 To rear bumper, convertible fills gap between deck lid & bumper, molded rubber with metal insert . . . . . C4SZ-76403B34-A 124.95

# BUMPER



## Rear Bumper Center Plastic Emblems, Housing & Parts

1964	Plastic emblem, "THUNDERBIRD" in block letters . . . . .	C4SZ-17B850-A	43.95
1965	Plastic emblem, Thunderbird emblem . . . . .	C5SZ-17B850-C	43.95
64-65	Center emblem housing, chrome . . . . .	C4SZ-17B847-A	79.95
64-65	Retainer plate, rear bumper center emblem . . . . .	C4SZ-17B851-A	13.95
64-65	Mounting pad, rear bumper center emblem . . . . .	C4SZ-17B852-A	4.95

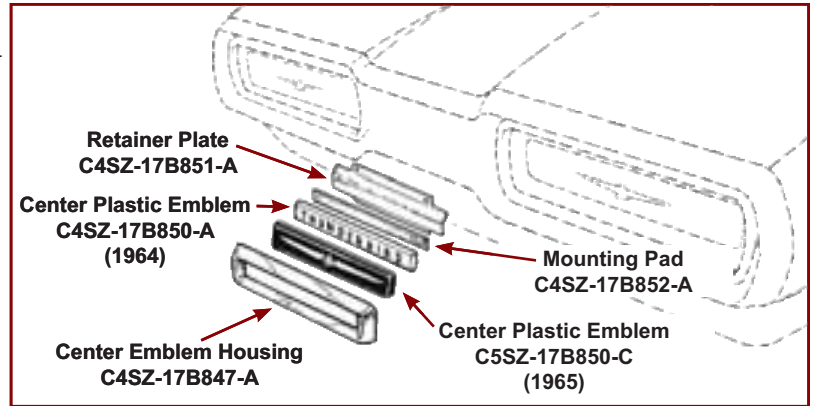

# HEATER

## Heater Cores & Seal



Heater cores for Big Birds have been a problem for many years. Now, that problem is over. MAC's is proud to announce that we now carry a complete line of brand new, original type heater cores. Made to factory specifications assuring that they are easy to install, these cores will give you years of trouble free service. Call, fax or go on-line & order yours today!

58-60	1 pipe with 3 tabs . . . . .	B8S-18476-A	98.95
61-62	1 pipe with 2 studs, used 1961, early 1962, late '62 has 3 studs . . . . .	C1SZ-18476-A	98.95
62-63	1 pipe with 3 studs, usage began in late 1962 . . . . .	C2SZ-18476-A	98.95
64-66	2 short pipes, with A/C . . . . .	C4SZ-18476-A	98.95
64-66	2 long pipes, without A/C . . . . .	C4SZ-18476-B	98.95
64-66	Heater core tubes at firewall seal, without A/C . . . . .	C4SZ-18596	3.95

## Heater Resistor



65-66	Heater blower motor resistor. . . . .	C2OA-18591-AR	22.95
-------	---------------------------------------	---------------	-------

## Heater Core to Case Gaskets



61-63	Foam . . . . .	C1SZ-18658-A	3.95
64-66	Foam, with A/C . . . . .	C1SZ-18658-A	3.95

## Heater Hoses & Parts

58-66	Heater hose, 5/8" inside diameter, sold by the foot (as required) . . . . .	18472-58	0.95 foot
58-66	Reproduction heater hose set, 5/8" ID with white stripe & correct grooves, two 4 foot long pieces . . . . .	C5ZZ-18472-ST	24.95 set
58-63	Heater hose bracket . . . . .	B8S-18481-A	7.95
62-66	Heater hose Y-pipe, heater hose to carburetor spacer, late 62-66 . . . . .	C2SZ-18663	12.95



64-66	<b>NEW</b> Heater hose bracket. . . . .	C4SZ-18481	4.95
-------	-----------------------------------------	------------	------

## Heater Hose Clamps



62-66	<b>Save</b> Tower hose clamp set, includes all 12 heater hose clamps, correct reproduction . . . . .	C2SZ-8287-HST	18.95 set
58-66	Tower hose clamp, for heater hose, correct reproduction (as required). . . . .	HT34	1.95

## Hose Connectors



58-60	3/8" thread, 20° bend (1 or 2 required) . . . . .	8A-18599-R	11.95
1960	3/8" thread on one end & a hose nipple on the other, exact reproduction . . . . .	8M-18599	11.95

## Heater Hot Water Control Valve Kits

While this kit does not look like the original, it does do the same job. The new shutoff valve is placed in the engine compartment so it's obvious that you are using a replacement setup. The beauty of this kit is that it is less than you would pay for a rebuilt original valve & as it's all brand new parts, it will likely outlast the car. Each kit includes a new pipe & fitting with a rubber seal to attach to your core, a new valve & a new cable.



58-60	Replacement style. . . . .	B8S-18495-KT	72.95 kit
61-63	Replacement style. . . . .	C1SZ-18495-KT	64.95 kit





### Heater Hot Water Control Valve Seal



58-63 Heater hot water control valve to heater core seal, rubber . . . . . B7A-19460-A 1.95

### Heater Blower Motors

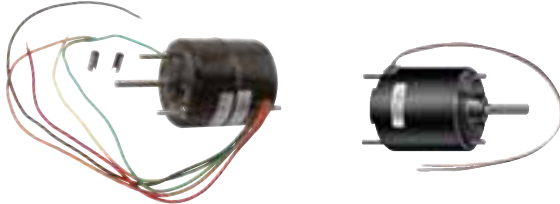

1960 With or without A/C . . . . . B6A-18527-B 124.95  
61-63 Non-vented, without A/C . . . . . 18527-1773 58.95  
64-66 Non-vented, without A/C, **Motorcraft** (not shown) . . . . . C1TZ-18527-A 85.95



58-60 Heater blower motor to housing grommet . . . . . B8S-18583-A 5.95

### Heater & Air Conditioning Control Cables

Replace those "cranky" old cables with our smooth operating new reproductions & you'll have your cables operating like new, so dial MAC's number & place your order now!

1958 Cable, heater temperature control . . B8S-18518-A 23.95  
1958 Cable, heater & defroster control . . B8S-18548-A 23.95  
1958 Cable, right air . . . . . B8S-18552-A 23.95  
59-60 Cable, off & heat . . . . . B9S-18552-A 23.95  
59-60 Cable, heater temperature control . . B9S-18518-A 23.95  
59-60 Cable, defroster control . . . . . B9S-18548-A 23.95  
61-63 Cable, heater temperature control . C1SZ-18518-A 23.95  
61-63 Cable, on & off, heater & defroster control . . . . . C1SZ-18548-A 23.95  
61-63 Cable, A/C temperature control . . . FDU-19988-A 23.95  
64-66 Cable, heater temperature control . C4SZ-18552-A 23.95  
64-66 Cable, on & off, heater & defroster control . . . . . C4SZ-18518-A 23.95



58-63 Heater control cable retaining clip . . B8S-18548-CLIP 3.95

### Heater & Air Conditioner Control Knobs

(2 required)

1959 Gold colored insert . . . . . B9SF-19A603-A 11.95  
1960 Silver colored insert . . . . . COSF-19A603-A 11.95

### Fresh Air Inlet Ducts & Seal

Peel all that "temporary" duct tape off & install a beautifully reproduced air inlet duct today! The "squeeze" type wire clip is molded into the duct as original for a look that can't be told from factory new.



61-63 Duct, with or without A/C . . . . . C1SF-18B259-A 44.95  
64-66 Duct, with A/C . . . . . C1SF-18B259-A 44.95  
64-66 Seal, without A/C . . . . . C5SZ-18A596-A 14.95

### Defroster Hoses



61-66 2-1/2" ID, sold in 3 foot lengths, customer must cut to fit (as required) . . . . . B5A-18556-C 19.95  
65-66 Set, with A/C . . . . . C5SZ-18A620-AST 13.95 set  
65-66 Set, without A/C . . . . . C5SZ-18A620-BST 13.95 set

*The Ford Motor Company used quality components on their air conditioning systems & many remained functional for many years into the later life of their cars, if they were kept properly charged & maintained. While we all love driving our classic Fords to various car shows & cruise-ins all summer long, there are often days when nice, cold air conditioning makes summer events much more enjoyable. Here at MAC's we have a wide assortment of parts for your factory Ford air conditioning system. Call today!*

### Air Conditioner Compressors

These compressors are aftermarket replacements for the York & Tecumseh O.E.M. factory-installed A/C units, not dealer-installed "hang-on" units. No core exchange is required.

#### Remanufactured

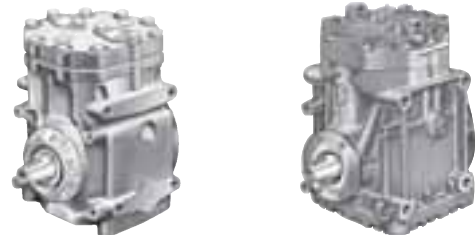

58-62 Cast iron case, Tecumseh . . . . . 19703-AR 194.95  
63-66 Aluminum case, York . . . . . 19703-BR 169.95

#### New

63-66 Aluminum case, York . . . . . 19703-BN 331.95

Compressors do not include external parts such as the clutch, brackets or connectors, etc.

### Air Conditioner Compressor Crankshaft Seal Kit



65-66 **NEW** For York compressor . . . C9AZ-19655-B 22.95 kit

### Air Conditioner Compressor Clutches

Remanufactured—no core exchange is required



65-66 With 6" diameter single groove pulley, includes the hub, coil & pulley . . . . . 2884-6652 189.95



## Compressor Clutch Brush Assembly



65-66 ..... C8SZ-2979-A 34.95

## Air Conditioner Door Vacuum Motor

Ford initially made several different versions of vacuum actuators. The only difference was the length of the arm as each was designed to fit a specific application. Ford created a universal actuator by adding a longer arm that could be cut down when necessary. This one "universal" actuator now can be used on all 1961-66 T-Birds.

The arm is 4-11/16" long with a flat end, it will need to be cut to the proper length.



61-66 **Motorcraft service replacement**  
(1 to 5 required) ..... COAF-18A318-B 53.95

## Air Conditioner Blower Motor Vent Hoses & Seal

The double 90° bend hose pulls cooled air from inside the car, which helps to cool the blower motor. The single 90° hose directs cooled air into the engine compartment.



61-66 Vent hose, 90° bend ..... COAZ-19A786-B 4.95  
61-66 Vent hose, double 90° bend .... COAZ-19A786-A 6.95  
61-66 Seal, A/C blower motor cover at firewall ..... C1SZ-19A797 13.95

## Intake Manifold Water Fitting

61-65 With integral air conditioning ..... C4SZ-18663-A 24.95

## Air Conditioner Receiver/ Driers

If you are replacing your compressor, experts all agree that you should also replace your receiver/ drier. We now have a full line of brand new driers, all made to factory specifications. Complete you're A/C overhaul with the best parts, made the right way.

58-60 Air conditioner receiver/ drier .... COSF-19959-B 129.95  
61-65 Air conditioner receiver/ drier .... C2SZ-19959-A 129.95  
1966 Air conditioner receiver/ drier .... C6SZ-19959-A 129.95

## Air Conditioner Hose Tags

This tag was originally attached to one of the A/C hoses. It was held on with the aluminum strap listed below.



1961 Aluminum ..... 61-ACTAG 16.95  
1962 Aluminum ..... 62-ACTAG 16.95  
1963 Aluminum (shown) ..... 63-ACTAG 16.95  
1964 Aluminum ..... 64-ACTAG 16.95  
65-66 Aluminum ..... 656-ACTAG 16.95

61-66 Tag strap, aluminum, used to attach the tags listed above ..... 8M-18954 2.95

## Air Conditioner Compressor Support Braces & Spacers

Whenever someone removes a complete air conditioning system from a car the items that always seem to get misplaced are the braces & spacers for the compressor. The problem is that you can't mount the compressor without these & they are unique to '64, '65 & '66.

**NOW THEY HAVE BEEN REPRODUCED!**

The braces all have a durable powder-coated finish so they will look good for years to come.

1964 Support brace, for the front of the A/C compressor ..... C4AZ-2882-A 29.95  
1964 Support brace, for the rear of the A/C compressor ..... C4SZ-2902-A 29.95  
1965 Support brace, for the front of the A/C compressor ..... C5AZ-2888-C 29.95  
1965 Support brace, for the rear of the A/C compressor ..... C5AZ-2889-A 29.95  
1966 Support brace, for the front of the A/C compressor ..... C5AZ-2888-C 29.95  
1966 Support brace, for the rear of the A/C compressor ..... C6SZ-2889-A 29.95  
  
1965 Spacer, for the A/C compressor support brace, 49/64" long ..... C4AZ-2887-B 4.95  
1966 Spacer, for the A/C compressor support brace, 1-1/4" long (2 required) ..... C6SZ-2887-A 4.95

## Air Conditioner Compressor Support Braces & Spacers

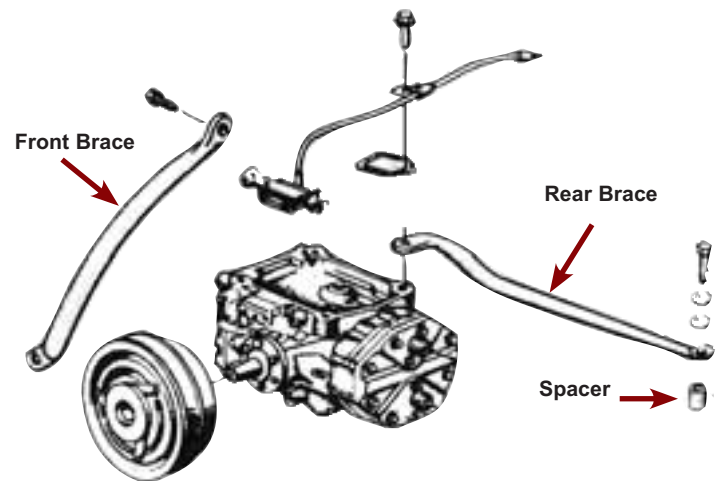

## Air Conditioner Vacuum Canisters



61-65 **NEW** Double nipple type .... C5AZ-19A566-B 52.95  
1966 **NEW** Single nipple type .... C6SZ-19A566-A 52.95



MAC's has assembled an exhaustive selection of weatherstripping as possible, one of the largest on the market today.

While not the most exciting of parts, these seals are some of the most important pieces to your restoration as nothing could be worse when you

think you are finally done to have the elements come raining in all over your new interior!

**MAC's is your one stop source for quality weatherstripping for your Thunderbird!**



## Body to Bumper Seals



58-60 Front . . . . . B8SZ-16304-PR 14.95 pair



- 61-63 Set, includes 2 front bumper to fender seals & 2 rear bumper "Q" seals . . . . . C1SZ-16304-ST 230.95 set
- 61-63 Front . . . . . C1SZ-16304-FRT 108.95 pair
- 61-63 Rear . . . . . C1SZ-17A970-PR 129.95 pair
- 58-60 Seal retainer, use with body to bumper seals B8SZ-16304-PR (2 required) . . . . . B8SZ-16311-A 9.95

## Radiator Air Baffle & Staples

- 62-63 Baffle, mounts on radiator support . C2SZ-8B093-A 8.95
- 62-63 Staples, 16 pieces . . . . . 2HK28N 1.95 kit

## Radiator Support to Hood Seals

- 58-60 Rubber, sold as a pair . . . . . B8S-16137-PR 6.95 pair
- 62-63 Rubber, attaches to radiator core support . . . . . C2SZ-8B093-A 8.95



- 64-66 Rubber, without pins . . . . . C4SZ-16A238-A 7.95
- 64-66 Rubber, with pins . . . . . C4SZ-16A238-KT 11.95 kit

## Hood to Cowl Seals

- 58-60 Rubber . . . . . B8S-16740-A 9.95
- 61-66 Rubber . . . . . C1SZ-16740-A 9.95

## Windshield Seals



- 58-60 Fits hardtop & convertible . . . . . B8S-6303110-A 79.95
- 61-63 Fits hardtop . . . . . C1SB-6303110-C 74.95
- 61-63 Fits convertible . . . . . C1SB-7603110-C 99.95
- 64-66 Fits hardtop & convertible . . . . . C4SZ-6303110-A 69.95

## "A" Pillar Seals

Since the "A" pillar seals are a separate item they are not included with the convertible roof rail seal sets. These seal the front edge of the door glass from the roof down to the body.



- 58-60 Rubber, hardtop . . . . . B8S-6302626-PR 13.95 pair
- 58-60 Rubber, convertible . . . . . B8S-7602626-PR 49.95 pair
- 61-63 Rubber, convertible . . . . . C1SZ-7603198-PR 56.95 pair
- 64-66 Rubber, convertible . . . . . C6SZ-7602626-PR 44.95 pair

We recommend our RSP28 adhesive because it's the best there is!



- ALL Rubber weatherstrip & felt glass channel adhesive, black, 3M brand, 5 oz. tube . . RSP28 8.75





Nothing says "old" like cracked & shrunken weatherstripping & old rubber parts on your classic ride. Doors don't shut properly, windows don't seal well & rattles abound.

MAC's has a complete listing of the "soft" restoration parts to make your Ford's doors seal up like new again.

## Door Seals

MAC's door seals are made from the finest weather-resistant extruded sponge rubber. The molded ends are heat-bonded, not glued, to the extrusion. Metal inserts are used as original.

1 pair does both doors.

58-60	Rubber. ....	B8S-6320530-PR	72.95 pair
61-62	Rubber. ....	C1SZ-6320530-PR	72.95 pair
1963	Rubber. ....	C3SZ-6320530-PR	72.95 pair
64-65	Rubber. ....	C4SZ-6320530-PR	74.95 pair
1966	Rubber. ....	C6SZ-6320530-PR	67.95 pair

See our door seal hardware on page 242



Door seals & inner dog leg seals both need some adhesive to "help" them do their job of blocking wind, water & road noise. We recommend our RSP28 adhesive because it's the best there is!



ALL	Door seal & felt glass channel adhesive, black, 3M brand, 5 oz. tube . . . . .	RSP28	8.75
-----	--------------------------------------------------------------------------------	-------	------

## Door Inner Dog Leg Seal

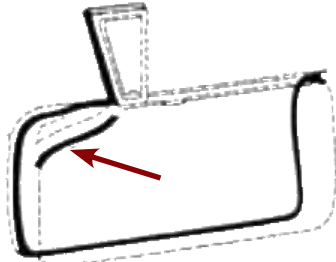

58-60	1 pair does both doors . . . . .	B8S-6320580-PR	34.95 pair
-------	----------------------------------	----------------	------------

## Vent Bar Channels

The front of your door glass slides up & down in this channel. When it gets worn your door glass moves back & forth & rattles all day long. Install a new vent bar channel or vent bar channel insert & your ears won't believe the difference! The vent bar channels listed below are the door glass run at the front of the door.

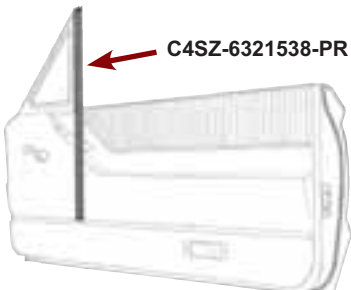

58-60	Vent bar channel . . . . .	B8S-6321538-PR	67.95 pair
64-66	Vent bar channel . . . . .	C4SZ-6321538-PR	67.95 pair

For 1961-63 vent bar channels, see the top of the next column.

The vent bar channel below is a little different; the door glass for 61-63 is curved, we can only install a new glass run in your original curved vent bars. Send your original vent bars to us first & we'll install new linings with a stainless steel bead just like Ford designed it originally.

61-63	Vent bar channel, allow 3 to 4 weeks turnaround time . . . . .	C1SB-6321538-PR	123.95 pair
-------	----------------------------------------------------------------	-----------------	-------------

## Upper Vent Bar Channel Seals

58-60	Includes rivets . . . . .	B7A-7621774-PR	17.95 pair
61-63	Includes rivets . . . . .	C2SZ-6321774-PR	22.95 pair
64-66	Includes rivets . . . . .	C6SZ-6321774-PR	22.95 pair

## Vent Window Seals

1958-1966 Thunderbird vent window seals are made in 2 pieces. One piece (the "vent window seal") seals the front angled edge across the bottom. A separate piece is made for the vertical back edge of the vent window. Both are listed below. Because they are used quite often, vent window seals are usually so worn that they leak water & air.

Keep water from staining your door panels & stop that annoying whistling at highway speeds by replacing those vent window seals today, you'll be happy you did. To seal the whole vent you will need to purchase both the window seal & the back edge seal listed.



58-60	. . . . .	B8S-6321448-PR	80.95 pair
61-63	. . . . .	C1SZ-6321448-PR	96.95 pair
64-66	(shown) . . . . .	C4SZ-6321448-PR	80.95 pair

## Seal for Back Edge of Vent Window

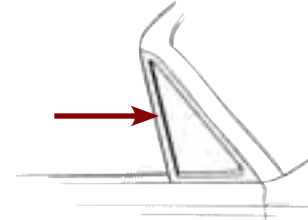

58-60	. . . . .	B8S-6321450-PR	19.95 pair
61-63	. . . . .	C1SZ-6321450-PR	19.95 pair
64-66	. . . . .	C4SZ-6321450-PR	19.95 pair

## Vent Window Frame Seal

64-66	Vent window frame seal . . . . .	C4SB-6322380-PR	22.95 pair
-------	----------------------------------	-----------------	------------

## Vent Window Handles

58-60	Including button, chrome, right . . . . .	B7AZ-7022916-R	25.95
58-60	Including button, chrome, left . . . . .	B7AZ-7022917-L	25.95



61-63	No button, chrome, right . . . . .	C1SB-6322916-R	17.95
61-63	No button, chrome, left . . . . .	C1SB-6322917-L	17.95

## Vent Window Parts (2 required)

58-60	Vent window handle spring . . . . .	B9A-6422986-A	0.95
-------	-------------------------------------	---------------	------



61-64	Vent window frame pivot spring . . . . .	B5A-7022926-A	9.95
-------	------------------------------------------	---------------	------



## Manual Vent Window Regulator Gears

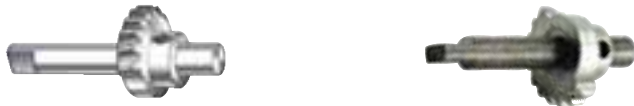

- 64-66 Right .....C4SZ-6323402-B 36.95
- 64-66 Left .....C4SZ-6323403-B 36.95

*Belt weatherstripping is what keeps water & other debris from going down into the door cavity & rusting out the door bottom. After 40+ years of opening & closing the windows these weatherstrips are usually pretty worn out. Get rid of the rattles & stop the leaks—replace them now using our economical kits!*

## Belt Weatherstrip Kits

Includes inner & outer pieces.

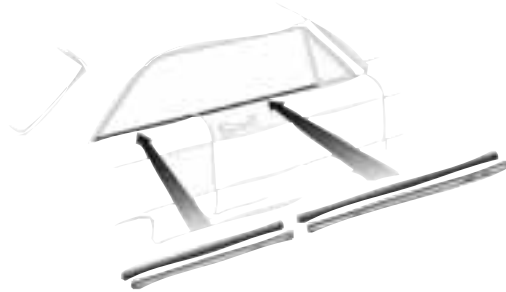

- 58-60 8 pieces, does front & rear windows, coupe. ....B8S-6321452-KT 89.95 kit
- 58-60 8 pieces, does front & rear windows, convertible. ....B8S-7621452-KT 79.95 kit
- 61-63 8 pieces, does front & rear windows, coupe. ....C1SB-6321452-KT 85.95 kit
- 61-63 10 pieces, does front & rear windows, convertible. ....C1SB-7621452-KT 90.95 kit
- 64-66 8 pieces, does front & rear windows, all coupes, **except** 1966 body styles 63C & 63D. ....C4SZ-6321452-KT 85.95 kit
- 64-66 8 pieces, does front & rear windows, convertible. ....C4SZ-7621452-KT 89.95 kit
- 1966 **NEW** =4 pieces, includes inner & outer pieces for doors, body style 63C Town Hardtop & 63D Town Landau only. ....C6SZ-6321452-KT 69.95 kit



- ALL Door seal & felt glass channel adhesive, black, 3M brand, 5 oz. tube . . RSP28 8.75

## Roof Side Rail Seals

*When the roof rail seals leak, your door panels & carpet get the worst of it—replace them today to keep your doors & floors dry. 1958 thru 63 kits do not include the convertible top arm pads listed on the top of the next page.*

### Convertible

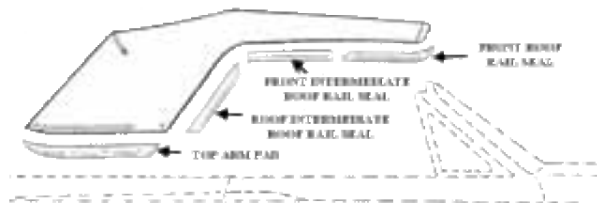

- 58-60 Kit, 6 pieces. ....B8S-7651222-KT 295.95 kit
- 61-63 Kit, 7 pieces, includes front header seal & T-bolts .....C1SZ-7651222-KT 224.95 kit
- 64-66 Kit, 7 pieces, includes top arm pads & header seal. ....C4SZ-7651222-KT 207.95 kit

## Hardtop

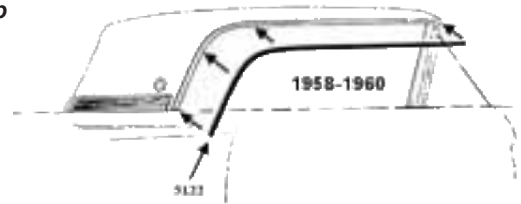

- 58-60 Complete with metal core, hardtop only, right & left . . . . B8S-6351222-PR 197.95 pair
- 61-63 Complete with metal core, hardtop only, right & left . . . . C1SZ-6351222-PR 199.95 pair

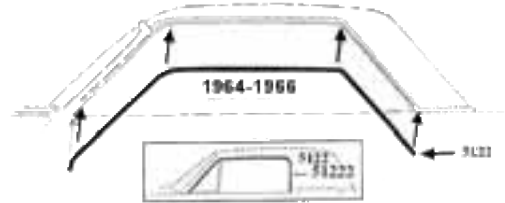

TOWN MODELS 63C & 63D, 1966 ONLY

- 64-66 With metal eyelet moulded inside tip for windshield post screw, hardtop, **except** 1966 Town Hardtop 63C & Town Landau 63D right & left . . . . . C4SZ-6351222-PR 77.95 pair
- 1966 With metal eyelet molded inside tip for windshield post screw, Town Hardtop 63C & Town Landau 63D only, right & left . . . . . C6SZ-6351222-PR 115.95 pair

## Roof Hardware



- 58-66 **NEW** T-bolt for convertible roof rail seals (as required) . . . . . 35222-S 1.95
- 64-66 Roof rail weatherstrip screw set, 24 round washer-head screws, 1 set does both sides . . . . . 2HK81A 37.95 set

**DON'T FORGET THE ADHESIVE !**  
*Your weatherstrip deserves the best & our RSP28 adhesive is the best, order a tube today.*

## Convertible Front Header Seals

All of these seals attach to the underside of the convertible top.



- 58-60 "U" shaped channel, rubber with metal core, attaches to front of top . . . . . B8S-7651330-A 79.95
- 58-60 Bow seal, rubber, attaches to front of #1 top bow . . . . . B8S-7651338-A 17.95
- 61-63 Rubber, attaches to #1 top bow, included in roof rail seal kit C1SZ-7651222-KT, listed to the left . . . . . C1SZ-76514A28-A 38.95

## Convertible Top Outer Front Seals

This seal attaches to the outer front edge of the top. When the top is up, this seal rests on the windshield header.

- 61-66 Rubber, black . . . . . C1SZ-7651325-BLK 47.95
- 61-66 Rubber, white . . . . . C1SZ-7651325-WHT 47.95
- 61-66 Rubber, beige . . . . . C1SZ-7651325-BGE 47.95



## Convertible Top Arm Pads

Convertible top arm pads attach to the bottom of the top arm. When your top is down they rest on the painted surface of the body. These are rubber pads with a heavy steel core.



- 58-60 Rubber, not included in the roof rail seal kit (shown) . . . . B8S-7651566-PR 88.95 pair
- 61-63 Rubber, not included in the roof rail seal kit . . . . . C1SZ-7651566-PR 79.95 pair
- 64-66 Rubber, included in the roof rail seal kit . . . . . C4SZ-7651566-PR 60.95 pair

## Convertible Trunk Weatherstrip Kits

- 58-60 4-piece kit . . . . . B8S-7643720-KT 89.95 kit
- 61-63 4-piece kit . . . . . C1SZ-7643720-KT 79.95 kit
- 64-65 23-piece kit, before 2-15-65 . . . C4SZ-7643720-KT 269.95 kit
- 65-66 19-piece kit, from 2-15-65 . . . . C6SZ-7643720-KT 267.95 kit



**DON'T FORGET THE ADHESIVE !**  
Your weatherstrip deserves the best & our RSP28 adhesive is the best, order a tube today.

## Convertible Top Arm Seal

This seal attaches beneath the package tray (also called the flip lid). The flat top frame arm goes thru the slot in this seal.

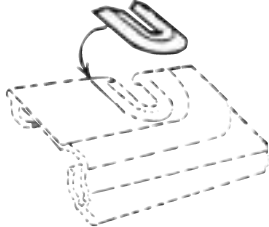

- 64-66 . . . . . C4SZ-76465A10-PR 9.95 pair

## Quarter Window Seal

- 58-60 Quarter window seal . . . . . B8S-6329500-PR 9.95 pair

## Quarter Window Front Seals

On most cars the seal between the door glass & the quarter glass is attached to the vertical front edge of the quarter glass. If you have a leak between your windows this new seal will cure the problem immediately.



- 58-60 Rubber, with metal insert, coupe or convertible . . . . . B9A-6330146-PR 28.95 pair
- 61-63 Rubber, with metal insert, coupe or convertible . . . . . C3SZ-6330146-PR 28.95 pair
- 64-66 Rubber, with metal insert, coupe or convertible . . . . . C4SZ-6330146-PR 26.95 pair

## Quarter Post Seals



- 58-60 Rubber, coupe or convertible . . B8S-6328306-PR 17.95 pair



- 61-63 Rubber, coupe or convertible . C2SZ-6328306-PR 15.95 pair



- 64-66 Rubber, coupe or convertible . C4SZ-6328306-PR 15.95 pair

## Package Tray Seal

- 58-63 Coupe, this seal fits under the package tray where it meets the rear seat upper finish panel . . C1SB-7660796-A 12.95

## Back Window Seals

- 58-60 Rubber, coupe . . . . . B8S-6342084-A 89.95
- 61-63 Rubber, coupe . . . . . C1SZ-6342084-A 96.95
- 64-66 Rubber, coupe . . . . . C4SZ-6342084-A 75.95

## Coupe Trunk Lid Seals

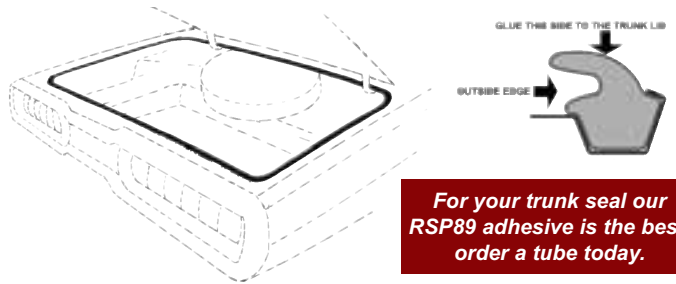

**For your trunk seal our RSP89 adhesive is the best, order a tube today.**

- 58-63 . . . . . COMB-6443720-C 19.95
- 64-66 . . . . . C3AZ-6243720-A 17.95

## Rear Body Panel Seals

Pre-punched holes.

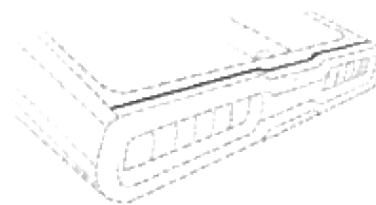

- 64-66 Coupe, black . . . . . C4SZ-63403C50-BLK 22.95
- 64-66 Coupe, gray . . . . . C4SZ-63403C50-GRY 22.95



- 64-66 Clip (16 required) . . . . . C4SZ-6340351-A 1.95





## Rear Bumper Splash Panels

- 64-66 Metal, convertible . . . . . C4SZ-16D556-PR 49.95 pair
- 64-66 Rubber, coupe . . . . . C4SZ-63403C40 14.95 pair

## Rear Bumper Stone Deflector Seal

- 58-60 . . . . . B8S-17832-PR 19.95 pair

## Lower Back Panel Splash Shields

- 61-63 To rear bumper, coupe or convertible, rubber . . . . . C1SZ-63403B34-PR 14.95 pair

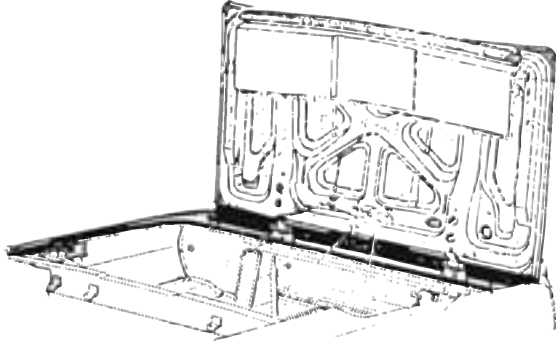

- 64-66 To rear bumper, convertible, fills gap between deck lid & bumper, molded rubber with metal insert . . . . . C4SZ-76403B34-A 124.95

We carry the best adhesive you can buy to help secure window, roof & trunk seals to your car.



- ALL Door seal & felt glass channel adhesive, black, 3M brand, 5 oz. tube . . . . . RSP28 8.75



- ALL Trunk lid seal adhesive, yellow, 3M brand, 5 oz. tube . . . . . RSP89 7.95



To help get your seals & weatherstripping separated from the glass, use this! Loosen up tough, hardened old glue & weatherstrip adhesive, with this terrific quick release agent. It makes quick & easy work out of an otherwise miserable job. Your new weatherstripping will have a better fit when the buildup of old glue is removed. Get rid of that old glue the easy way, with quick release agent from MAC's.



- ALL 14 oz. spray can . . . . . RSP958 \* 6.95

\* **HAZARDOUS MATERIAL** can only be shipped by ground/ surface within the U.S. because of government regulations.

**THUNDERBIRD ORDER FORM 2008-09**

**MAC's**  

P.O. Box 238, Lockport, NY 14095-0238 ORDER LINE: (U.S. or Canada) **(800) 777-0948**

Local Phone Number **(716) 210-1340** 24-Hour Fax: **(716) 210-1370** Email: **customerservice@macsauto.com** Or visit our Website **www.macsautoparts.com**

(Please print clearly)

Name \_\_\_\_\_ E-mail Address \_\_\_\_\_ Date \_\_\_\_\_

Street \_\_\_\_\_ Customer # \_\_\_\_\_

City \_\_\_\_\_ State \_\_\_\_\_ Area Code & Phone ( \_\_\_\_\_ ) \_\_\_\_\_ Zip \_\_\_\_\_

Year of vehicle \_\_\_\_\_ Body Style \_\_\_\_\_ Country \_\_\_\_\_

Is this your first order with MAC's? Yes  No

Payment enclosed (Bank or Postal money orders & Checks)

C.O.D. (U.S. only - certified check unless prior arrangements are made.) NOTE: UPS charges \$9.00 per box for C.O.D.

Card # \_\_\_\_\_ Expiration Date \_\_\_\_\_

Signature \_\_\_\_\_

#	Part Number	Page #	Part Name	Qty.	Price Ea.	Total Amt.
1						
2						
3						
4						
5						
6						
7						
8						
9						
10						
11						
12						

**Order Forms Located in the Back of the Catalog**



## Door Scuff Plates, Extensions & Emblem

The first thing you see when you open the door is the scuff plate. Most are in pretty rough shape & can make a decent interior look shabby. Replace them today with our top-quality reproductions.



58-60 The emblem is stamped into the scuff plate, as original . . . . . B8S-6313208-PR 117.95 pair



61-62 The emblem is stamped into the scuff plate, as original . . . . . C1SZ-6313208-PR 142.95 pair



1963 Does not include emblems- sold separately below . . . . . C3SZ-6313208-PR 116.95 pair



64-66 Does not include emblems- sold separately below . . . . . C4SZ-6313208-PR 99.95 pair  
Scuff plate screws are available in Hardware, pg 242

### Door Scuff Plate Extension

64-66 Aluminum, these fit underneath the scuff plate & extend downward to the rocker panel area . . . . . C4SZ-6313208-EXT 32.95 pair

### Door Scuff Plate Emblem



63-66 Metal with adhesive backing, black background (2 required) . . . . . C4SZ-6313208-E 2.95

## Door Latches



1964 Right, without vacuum door locks . . . . . C4SZ-6321812-CR 57.95

1964 Left, without vacuum door locks (shown) . . . . . C4SZ-6321813-CR 57.95

### Door Latch Bushing (2 required)

64-66 . . . . . C4SZ-6321801-A 4.95

## Striker Plate Parts



58-60 Shim, metal (as required) . . . . . COAB-6422058-A 4.95



61-63 Insert, fits right or left, with "teeth" to hold it in place (2 required) . . . . . C2AZ-6222040-A 9.95

61-63 Auxiliary plate, right (shown) . . . . . C3SZ-6322014-A 4.95

61-63 Auxiliary plate, left . . . . . C3SZ-6322015-A 4.95



60-64 Striker plate bolt (6 required) . . . . . 358996-S 0.95

## Door Latch Striker Plate & Screw Set



65-66 Right or left, **Genuine Ford** (2 required) . . . . . C5AZ-6222008-A 25.95

65-66 Screw set, 4-piece set, one set does 2 doors . . . . . 378428-ST 3.95 set

## Door Latch Rod Retainer Clips

1964 Concours quality with plastic retainer, used from 3-1-64 . . . . . C3AZ-6221952-B 6.95

58-64 (as required) . . . . . B9AB-6421952-A 2.95

## Door Lock Buttons & Grommets

### Buttons

58-60 Black plastic (2 required) . . . . . B7A-7021850-A 7.95



61-63 Chrome (2 required) . . . . . C1VB-5721850-A 7.95

1964 Chrome (2 required) . . . . . C1VB-5721850-B 7.95

65-66 Chrome . . . . . C5DZ-6221850-PR 4.95 pair

### Grommets



58-60 Black plastic (2 required) . . . . . COSB-6321999-A 4.95

61-63 White plastic (2 required) . . . . . B9MB-5721999-A 4.95

1964 Clear plastic (2 required) . . . . . C4SZ-6321999-B 7.95

65-66 Clear plastic (2 required) . . . . . C5SZ-6321999-A 7.95

## Door Lock Levers



58-60 Right . . . . . B8S-6321970-R 14.95

58-60 Left (shown) . . . . . B8S-6321971-L 14.95

## Door Lock Lever Spring (2 required)

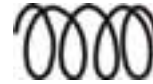

58-60 . . . . . B7A-7022075-A 0.95

Door hardware on pages 242 & 243



## Door Lock Cylinders & Keys

Each lock cylinder comes with a pair of matching keys. If you purchase more than one lock cylinder, they will each use different keys. For lock cylinder sets that all use the same key, see door lock & ignition key cylinder sets, listed below.



- 65-66 Does 1 door (2 required) . . . . . D2AZ-6521984-A 14.95
- 65-66 **Save** Does 2 doors . . . . . D2AZ-6521984-APR 20.95 pair

### Door Lock Cylinder to Door Seal

- 65-66 (2 required) . . . . . D2AZ-6521984-S 2.95

## Door Lock & Ignition Key Cylinder Sets

Each set contains 1 ignition key cylinder & 2-door lock cylinders—all tumblers use the same key.



- 58-60 Includes 2 keys . . . . . B2A-7022050-ST 69.95 set
- 61-63 Includes 2 keys, pre 3-18-63 . . . C3AZ-6222050-ST 49.95 set
- 63-64 Includes 2 keys, from 3-18-63 . . C3AZ-6222050-ST 49.95 set



- 65-66 Includes 2 keys . . . . . C9AZ-6222050-ST 39.95 set

## Door Lock Cover



- 1960 **NEW** Right only, includes spring . . . . . B2A-7021942-R 11.95

## Key Blanks (as required)



- 58-64 Ignition, single side . . . . . BA-3685-A 3.95
- 58-64 Trunk, single side . . . . . BA-3685-B 3.95
- 58-64 Ignition, single side, Anniversary edition gold-toned with the Ford crest on the head in brilliant colors . . . . . BA-3685-ANV 7.95
- 65-66 Ignition, N.O.S. with T-Bird logo on head . . . . . C5SZ-3685-A 3.95
- 65-66 Trunk, N.O.S. with T-Bird logo on head . . . . . C5SZ-3685-B 3.95

## Lower Door Drain Seal (1 to 6 required)

- 61-66 Lower door drain seal, 3 per door. C4AB-6220788 3.95

## Door Lock Cylinder Retaining Clips



- 58-60 . . . . . B8S-6322027-PR 8.95 pair
- 65-66 (2 required) (shown) . . . . . C5AZ-6222023-A 2.95

## Door Bumpers

Always check your car to see how many door bumpers are needed (usually 2 per door) & what size because of varying applications.



- 58-60 Door bumper (2 required) . . . . . B8S-13398-A 0.95
- 58-60 Door bumper, 7/16" high (as required) . 372164-PR 4.95 pair
- 61-63 Door bumper, lower, **Genuine Ford** (2 required) . . . . . 354860-S 1.95
- 64-66 Door bumper (as required) . . . . . C4SZ-6323030-A 0.95

## Door Hinge Pins & Bushings



If your door "drops" when you open it, your hinges are usually the cause. Many times, installing new bushings & pins will end your door hinge problems. Each hinge uses 1 pin & 2 bushings—pin might be cut to length as needed.

- 58-66 Pin, 3-9/16" x 11/32" diameter, cut to required length as needed (1 to 4 required) . . . . . B9A-5943030-AA 3.95
- 58-66 Bushing, sintered bronze (2 to 8 required) . . . . . C3AZ-5422841-B 0.95

## Inside Door Handles



- 58-63 Chrome, "C" clip not included (see below for "C" clip) (2 required) . . . . . COAZ-6422600-A 22.95

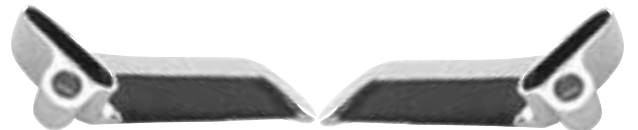

- 64-66 Chrome & black vinyl, right . . . . . C4SZ-6322600-A 26.95
- 64-66 Chrome & black vinyl, left . . . . . C4SZ-6322601-A 26.95

### Hardware

- 64-66 Hardware set, includes 2 chrome oval-head Phillips screws & 2 external-tooth lock washers . . . . . 2HK75A 2.95 set



- 58-63 Door handle "C" clip, square type spring steel (as required) . . . . . 357550-S 0.95





## Inside Door & Window Handle Spring *(as required)* \_\_\_\_\_



58-63 Also used on window handle . . . . . A48284 0.55

## Window Crank Handles \_\_\_\_\_



1958 Chrome, black knob, for front or rear windows, clip 357550-S required for installation (4 required) . . . . . B7A-7023342-AR 28.95  
 59-60 Chrome, white knob, for front or rear windows, includes "C" clip (4 required) . . . . . B8A-7023342-A 28.95



61-63 Chrome, chrome knob, for the front windows, clip 357550-S required for installation (2 required) . . . . . C2SZ-6323342-A 28.95  
 61-63 Chrome, chrome knob, quarter window, includes "C" clip (2 required) (not shown) . . . . . C2SZ-6330322-A 28.95



64-66 Chrome, for the front windows, clip 357550-S required for installation (2 required) . . . . . C4SZ-6323342-A 11.95  
 64-65 Chrome, chrome knob, quarter window, includes set screw (2 required) (not shown) . . . . . C4SZ-6330322-A 10.95



58-66 Window crank "C" clip, square type spring steel *(as required)* . . . . . 357550-S 0.95

*This tool makes removing door handle & window crank "C" clips a simple task.*



58-66 Door handle & window crank "C" clip removal tool, align tool with handle shaft for easy removal of "C" clips . . . . . TOOL-22600 6.95

## Window Crank Handle Knobs *(as required)* \_\_\_\_\_



Locking Pin

1958 Black, includes locking pin . . . . . B7A-7023352-A 5.95  
 59-60 White, includes locking pin . . . . . B8A-7023352-A 5.95  
 65-66 Black, includes mounting pin . . . . . C5AZ-6223352-A 9.95

## Window & Door Handle Nylon Plates \_\_\_\_\_

*This part doesn't look like it's important, but leave it off & see what happens. Its job is to keep the handles from rubbing on your door panel upholstery. Installs between handle & door panel.*



58-64 (6 required) . . . . . B7A-7023370-B 2.95  
 65-66 (4 required) . . . . . C5SZ-6323370-A 1.95

## Inside Door Handles Escutcheon & Plates \_\_\_\_\_



64-66 Escutcheon, die-cast chromed reproduction, sold in pairs . . . . . C4SZ-6322620-APR 11.95 pair



61-62 Plate, for quarter window cranks, chromed plastic (2 required) . . . . . C1SZ-63303A20-A 11.95  
 61-62 Plate, for door handles & door window cranks, chromed plastic (4 required) . . . . . C1SZ-63303A20-C 9.95  
 1963 Plate, for door handles & door window cranks, chromed plastic (4 required) . . . . . C1SZ-63303A20-A 11.95  
 1963 Plate, for quarter window cranks, chromed plastic (2 required) . . . . . C1SZ-63303A20-C 9.95

## Outside Door Handles \_\_\_\_\_

*Outside door handles take a beating from wind & weather, replace yours today with one of our richly chromed reproductions. MAC's door handles are die-cast & triple chrome plated. Door handle buttons are included.*



**BUY a PAIR & SAVE**

58-60 Includes button, right . . . . . B8S-6322400-B 72.95  
 58-60 Includes button, left . . . . . B8S-6322401-B 72.95  
 58-60 Includes buttons, right & left . . . . . B8S-6322400-PR 134.95 pair

*These door handles do not include the push buttons.*



64-66 Right, chrome (shown) . . . . . C4SZ-6322404-A 59.95  
 64-66 Left, chrome . . . . . C4SZ-6322405-A 59.95

## Outside Door Handle Push Buttons *(2 required)*

58-60 Button, right . . . . . B8S-6322454-B 19.95  
 58-60 Button, left . . . . . B8S-6322455-B 19.95



61-63 Includes chrome button, spring & bracket . . . . . C1SZ-6322454-A 33.95

*No push buttons are available for 64-66.*



Outside Door Handle Pads

Each set includes 4 pieces, enough to do 2 handles.



- 58-60 Rubber, 4-piece set... B8S-6322448-ST 8.95 set
64-66 Rubber, 4-piece set... C4SZ-6322448-ST 9.95 set

Power Window Motors

- 64-66 Right rear window, does not include gear... C5SZ-6330304-A 149.95
64-66 Left rear window, does not include gear... C5SZ-6330305-A 149.95
65-66 Right front window, does not include gear... C5SZ-6323394-A 149.95
65-66 Left front window, does not include gear... C5SZ-6323395-A 149.95

Power Window Switch & Wiring Assemblies



BRAND NEW POWER WINDOW SWITCHES! You don't have to take your console apart every season to remove & clean the switches anymore. Install these beautiful reproductions & they should last a lifetime.

- 1958 Switch, black knob, right front & left rear windows (2 required)... B8S-14529-B 36.95
1958 Switch, black knob, left front & right rear windows (2 required)... B8S-14529-A 36.95
59-60 Switch, white knob, left front & right rear window (2 required)... COSF-14529-BR 33.95
59-60 Switch, white knob, right front & left rear windows (2 required)... COSF-14529-AR 33.95
1963 Switch, chrome knob, on quarter trim panel (2 required)... C3SZ-14529-A 39.95

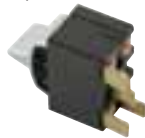

- 61-62 Switch & wiring, chrome knob, all windows (2 required)... C1SF-14529-A 39.95

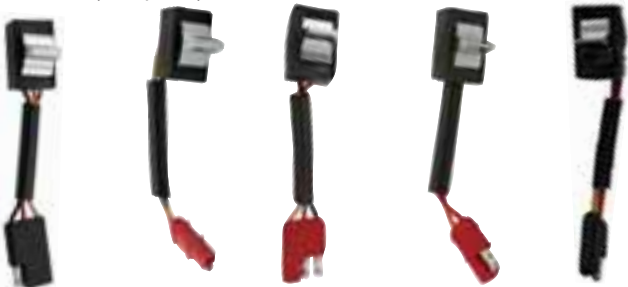

- 1963 Switch & wiring, left front & right rear windows (2 required) C3SZ-14632-CR 39.95
1963 Switch & wiring, right front & left rear windows (2 required) C3SZ-14632-DR 39.95
64-66 Switch & wiring, front windows (2 required) C4SZ-14632-GR 36.95
64-66 Switch & wiring, in console rear windows (2 required) C4SZ-14632-FR 39.95
64-66 Switch & wiring, chrome knob, on quarter trim panel for quarter windows or on console for vent windows (2 or 4 required) C4SZ-14632-C 41.95

Power Window Switch Knobs



- 1958 NEW Black... B8S-14529-KNOB 5.95
59-60 NEW White... COSF-14529-KNOB 5.95

Power Window Switch Clips

Nothing could be better—these clips are the ones that you broke or bent trying to get that switch out. Now you can replace any one or all with brand new clips. Check the illustration below so you know which style you need.



- 58-62 Holds switch to housing (as required) . . . FAA-14570-A 3.95
58-66 Holds the switch to the housing (as required) . . . . . FAA-14559-A 3.95
64-66 Holds the switch to the housing (as required) . . . . . C4AZ-14570-A 3.95
64-66 For quarter window switches (4 required) (not shown) . . . . . C4SZ-14570-B 2.95

Power Window Switch Plate Inserts

- 64-66 With front & rear power windows & lockout switch, 3 holes for 5 switches . . . . . C4SZ-14A307-A 16.95
65-66 With front & rear power windows, power vent windows & lockout switch, 5 holes for 7 switches . . . . . C5SZ-14A307-A 16.95
1966 Town landau & Town Hardtop only, with power vent windows, 2 holes for 4 switches . . . . . C6SZ-14A307-B 16.95

Power Window Switch Housings & Gaskets

Housings



- 58-60 For console mounted switches, 4 switch type . . . . . B8S-14528-A 23.95
61-63 For rear quarter window switches (2 required) (shown) . . . . . B5A-14528-B 23.95
61-62 Chrome, for switches & lockout on driver's door . . . . . C1AB-14527-A 55.95
1963 Goes under the switch plate on the console, holds 2 switches (2 required) . . . C3SZ-14528-B 17.95
1963 Single type on the quarter trim panel (2 required) . . . . . C3SZ-14528-A 20.95
64-66 For the console . . . . . C4SZ-14528-B 44.95
64-66 Single type on the quarter trim panel (2 required) . . . . . C4SZ-14528-C 20.95

Gaskets

- 61-62 For single switches (as required) . . . C1SZ-14554 3.95
1963 Single type on the quarter trim panel (2 required) . . . . . C3SZ-14554 2.95

Power Window Switch Plates



- 61-62 For left (drivers) door switch . . . . . C1AB-14524-A 13.95
61-62 For right (passenger) door switch . . . B7A-14523-A 7.95
1963 For rear quarter power window switches (2 required) . . . . . B7A-14523-A 7.95



## Power Window Switch Housing Escutcheons



- 61-62 Chrome, for passenger door power window switch . . . . . C1SB-14A183-A 11.95
- 61-63 Chrome, for rear quarter power window switch (2 required) . . . C1SB-14A183-A 11.95

## Power Window Lockout Switches & Parts



- 61-62 Power window lockout switch, chrome knob . . . . . C1SZ-14540-A 44.95
- 64-66 Power window lockout switch, chrome knob . . . . . C4SZ-14540-B 44.95
- 1966 Lockout cover plate, when lockout switch is not used (not shown) . . C6SZ-14A307 14.95
- 1966 Housing, used only when a lockout switch is not used. . . . . C6SZ-14A016 2.95

## Power Window Switch Bus Bars

- 58-60 For console switches, 1-5/16" long with 3/8" tab at 90° (2 required) . . COSB-14A033 3.95
- 61-62 For left door switches, 4-1/8" long with 5/8" tab at 90° . . . . . C1SZ-14A033 4.95
- 63-66 For console switches, 1-5/8" long with 5/8" tabs at 90° at both ends (2 required) . . . . . C3SZ-14A033 3.95

## Power Window Safety Relay



All power for the window switches has to go thru this relay. If none of your windows operate check this relay for power going in & coming out. Depending on model & year, these are usually located under the hood or instrument panel.



- 61-66 Power window safety relay . . . . . C1AF-14677-A 56.95

## Door Wiring Shields

- 58-60 Door wiring shield, right . . . . . B5S-4020768-A 36.95
- 58-60 Door wiring shield, left. . . . . B5S-4020769-A 36.95

## Power Window Wires

- 58-59 Regulator relay to circuit breaker, 66" long . . . . . B8S-14678-A 19.95
- 58-59 Regulator relay to starter solenoid, 55" long . . . . . FEY-14679-A 5.95

## Power & Manual Window Roller Assemblies (as required)

The window roller assembly attaches to the end of the window regulator arm. It's the part that slides back & forth in the channel, allowing the window to glide up & down smoothly. If your window tilts forward, back or isn't level when you roll it up, a damaged or broken roller might be the cause.



- 58-60 Front door & quarter window, includes clip. . . . . BA-7023240-A 3.95
- 61-66 Front door & quarter window, includes clip. . . . . COAB-6423240-B 1.95

## Power Window Motor Gears & Gasket

When you activate a power window switch & hear the motor running but your window doesn't move, it could be that your gear is stripped. Replace it with our perfect reproduction & get your windows to go up & down like new!



- 64-66 Motor gear, all quarter windows (2 required) . . . . . C9AZ-62234A24-B 23.95
- 65-66 Motor gear, front door, 1 gear does 1 motor (2 required) . . . . . C9AZ-62234A24-B 23.95
- 65-66 Motor to housing gasket (4 required) . . . . . C5SZ-6323396 2.95

## Power Window Regulator to Drive Assembly Coupling (4 required)



- 58-60 1-1/4" long x 7/8" diameter, used on the doors & quarter windows. . . . . B5A-7023440-A 14.95
- 61-64 3/4" long x 3/4" diameter, used on the doors & quarter windows (shown) . . . C1VB-5723440-A 14.95

## Glass Bedding (as required)



- 58-66 Glass bedding, 10' piece. . . . . A45963X 7.50 roll





With over 40 years of the sun's rays on them, your emblems have likely lost most of their shine. The paint fades, which makes them look dull & they just don't do your beautiful Bird justice. Check out what we have to offer, make your selections & place an order today!

## "Eyebrow" Mouldings

- 61-63 Hood moulding, right "eyebrow" over the headlight door . . . . . C1SB-16856-A 50.95
- 61-63 Hood moulding, left "eyebrow" over the headlight door . . . . . C1SB-16857-A 50.95
- 1966 Grille moulding, right "eyebrow" over the grille. . . . . C6SZ-8242-A 67.95
- 1966 Grille moulding, left "eyebrow" over the grille. . . . . C6SZ-8242-B 67.95

## Grille Ornament



- 1966 Chrome plated, with ribbed, turquoise insets & silver rear mounting bracket . . . C6SZ-8213-A 199.95

## Grille Bar Kit

- 1960 Grille bar kit, includes 3 vertical & 1 large horizontal bar, plus retaining clips. . . . . COSB-8200-KT 225.95 kit

## Upper Grille Panel Emblems



- 58-59 Chrome with aqua & red painted accents . . . . . B8S-8259-A 32.95
- 1960 Chrome with red painted accents, not concurs quality . . . . . COSB-8259-A 39.95

## Hood Emblems



- 61-63 Hood emblem bezel, chrome, requires 3 pal nuts (listed below) . . . . . C1SZ-16644-A 37.95



- 61-63 Hood emblem plastic insert, turquoise colored. . . . . C1SB-16607-B 23.95



- 1965 Hood emblem, chrome with "correct" brushed satin details, requires 3 pal nuts (listed below) . . . . . C5SZ-16637-A 44.95



- ALL Pal nut, self-threading, for 3/16" mounting stud . . . . . 373503-S 0.50

## Hood Letter Set

# THUNDERBIRD



- 1964 "Thunderbird," chrome with black paint, requires 22 barrel clips to install (listed below) . . . . . C4SZ-16606-ST 32.95 set
- ALL Barrel clip, .062" . . . . . 378362-S 0.50

## Hood Ornament

- 1966 "V" ornament, chrome, requires 3 pieces of 373503-S pal nuts to install . . C6SZ-16637-A 78.95

## Hood Moulding

- 61-63 This is the continuation of the "eyebrow" mouldings (see the "eyebrow" mouldings listing) . . . . . C1SZ-16958-A 67.95

## Body Side Moulding Kits

Beginning in 1961, Ford offered a body side moulding kit as an accessory. Until recently, if you were missing a piece on your car, that's the way it stayed, as replacement pieces were very hard to find. This beautiful reproduction includes all the mouldings & all the clips necessary to add this popular accessory to your Bird.



- 61-62 ~~NAME~~ OS Bright metal, 10 pieces .C1SZ-6329038-KT 288.95 kit
- 1964 ~~NAME~~ OS Bright metal, 8 pieces .C4SZ-6329038-KT 279.95 kit
- 1965 ~~NAME~~ OS Bright metal, 8 pieces .C5SZ-6329038-KT 279.95 kit
- 1966 ~~NAME~~ OS Bright metal, 8 pieces .C4SZ-6329038-KT 279.95 kit

## Moulding Clip

- 64-66 Moulding clip, used on body side mouldings, 17 or 18 per side . . . . . C2DZ-6420842-A 2.95

## Front Fender Peak Mouldings

These peak mouldings were a great styling look but they seemed to be easily damaged. Straightening & refinishing them is a costly, time-consuming job better left to professionals. We now have a better solution-our reproduction mouldings! Made from the original stainless steel, they are ready to install. Clips are not included.

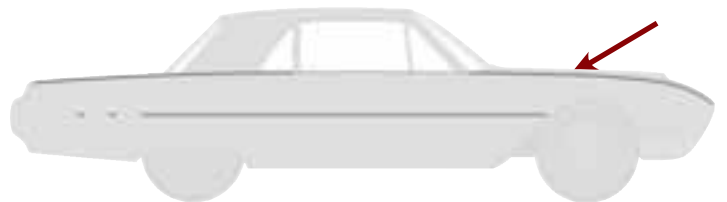

- 61-63 ~~NAME~~ OS Stainless steel, right, requires (5) C1SZ-6329144-A or (5) C2SZ-6329144-A & (1) C1SZ-16076-A (listed on the next page) to install. . . . . C1SB-16036-R 126.95
- 61-63 ~~NAME~~ OS Stainless steel, left, requires (5) C1SZ-6329144-A or (5) C2SZ-6329144-A & (1) C1SZ-16076-A (listed on the next page) to install. . . . . C1SB-16037-L 126.95



## Quarter Panel Peak Moulding & End Caps

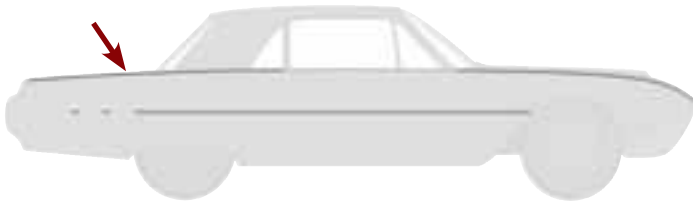

61-63 **OS** Quarter panel peak moulding, stainless steel, right or left, (2 required) . . . . C1SB-6329140-A 99.95



61-63 Peak moulding end cap, chrome die-cast, right . . . . C1SB-63291A24-B 31.95

61-63 Peak moulding end cap, chrome die-cast, left . . . . C1SB-63291A25-B 31.95

## Moulding Clips

The clips that hold the peak mouldings on do a great job when they are new. Once you remove them & try to reuse them, you'll find that many have stretched. We can send you as many as you need, in both original types-metal or plastic.



61-63 Moulding clips, tooth type, used on fender & quarter panel peak mouldings (as required) . . . . C1SZ-6329144-A 2.95

61-63 Moulding clips, plastic, used on fender & quarter panel peak mouldings (as required) . . . . C2SZ-6329144-A 1.95

61-63 Fender peak moulding end clip (4 required) . . . . C1SZ-16A076-A 2.95

## Fender Top Turn Indicators



64-65 Mounting hardware included . . . C4SZ-13A356-PR 69.95 pair

1966 Mounting hardware included . . . C6SZ-13A356-PR 69.95 pair

## Fender Top Ornaments



1958 Chrome, mounting hardware included . . . . . B8AZ-16178-PR 144.95 pair

1959 Chrome, mounting hardware included . . . . . B9AB-16178-PR 144.95 pair

1960 Chrome, mounting hardware included (2 required) . . . . . COSB-16178-A 72.95

1960 Gasket, for fender top ornament (2 required) . . . . . COSB-16178-GSKT 6.95

## Fender Ornaments

This is the piece that sets your '65 apart. Ford Motor Company advertising called it a "simulated air scoop." It is also most commonly pitted beyond repair or broken. We now carry brand new fender ornaments, so call us today & make a statement with your '65.



1965 Right (shown) . . . . . C5SZ-16228-AB 85.95

1965 Left . . . . . C5SZ-16229-AB 85.95

## Front Fender Nameplates (2 required)



58-59 Front fender nameplate, chrome, requires (5) 375890-S . . . . . C1SB-16098-A 24.95

61-62 Front fender nameplate, chrome, requires (5) 375890-S . . . . . C1SB-16098-A 24.95



63-64 Front fender nameplate, chrome, requires (6) 375890-S barrel clips (below) to install . . . . . C3SZ-6325622-AR 34.95



58-64 Barrel clip, medium size (as required) . . . . . 375890-S 0.60

## Sports Roadster Fender Ornament & Clip



62-63 Sports roadster emblem, chrome with red, white & blue accents, one was used on each fender & a third was on the Tonneau cover between the seats, requires (3) 375890-S barrel clips (below) to install (3 required) . . . . . C2SZ-16228-A 25.95



58-64 Barrel clip, medium size (as required) . . 375890-S 0.60



## Door Moulding

1959 "Spears" for right & left doors . . . B9S-6320980-PR 199.95 pair

## Door Edge Guards

61-63 Stainless steel . . . . . C3SZ-6320910-PR 28.95 pair

## Quarter Panel Nameplates (2 required)



1964 "Thunderbird" script, chrome, requires (6) 375890-S barrel clips (below) . . . . . C3SZ-6325622-AR 34.95



65-66 "Thunderbird" script, chrome, requires (6) 375890-S barrel clips (below) . . . . . C5SZ-6325622-AR 29.95



65-66 Clip (6 required) . . . . . 375890-S 0.60

## Landau Bars

*The following do not include the center emblem.*

62-63 Chrome with black painted accents . . . . . C2SZ-63517A20-BLK 199.95 pair

62-63 Chrome with white painted accents . . . . . C2SZ-63517A20-WHT 199.95 pair

1964 Chrome . . . . . C4SZ-63517A18 199.95 pair

1964 Emblem, chrome T-Bird on a white background (2 required) . . C4SZ-63517A18-WHT 31.95

1964 Emblem, chrome T-Bird on a black background (2 required) . . C4SZ-63517A18-BLK 31.95

1965 Chrome with black painted accents . . . . . C5SZ-63517A18-BLK 199.95 pair

1965 Chrome with white painted accents . . . . . C5SZ-63517A18-WHT 199.95 pair

1966 Chrome with black painted accents . . . . . C6SZ-63517A18-BLK 199.95 pair

1966 Chrome with white painted accents . . . . . C6SZ-63517A18-WHT 199.95 pair

## Lower Roof Side Mouldings

*Always hard to find in usable condition, finally they are now available as a reproduction!*

58-59 Lower roof side moulding . . . . . B8S-6351814-PR 209.95 pair

1960 Lower roof side moulding, ribbed style used after 12-14-59 . . . . COSB-63517A04-PR 209.95 pair



1964 **NEW** Lower roof side moulding, except Landau . . . . . C4SZ-63517A56-APR 202.95 pair



1964 **NEW** Lower roof side moulding, Landau models only . . . . C4SZ-63517A56-BPR 253.95 pair

65-66 Lower roof side moulding . . . . C5SZ-63517A56-PR 209.95 pair

1966 Lower roof side moulding, Town Landau & Town Hardtop only (models without 1/4 windows) . . . . . C6SZ-63517A56-PR 249.95 pair

## Quarter Panel Ornaments

1960 Vertical bars, early style with holes . . . . . COSB-6328984-AST 149.95 set

1960 Vertical bars, late style with studs . . . . . COSB-6328984-BST 149.95 set



1961 4 per side, each requires (3) 373503-S, pal nut listed below (8 required) . . . . . C1SB-63290A76-C 17.95



1962 Chrome with black paint, 3 per side, each requires (2) 373503-S pal nuts (listed below) (6 required) . C2SZ-63290A76-BR 23.95



61-62 Quarter panel ornament clip (as required) . . . . . 373503-S 0.50

## Door Emblems & Nameplates



1958 Door emblem, chrome with black paint, 5 per side, each nameplate requires (5) 375890-S barrel clips listed below to install (10 required) . . . . . B8S-6320980-A 20.95



1959 Door nameplate, "Thunderbird" script, chrome, each nameplate requires (5) 375890-S barrel clips listed below to install (2 required) . . . . . C1SB-16098-A 24.95



1960 Door nameplate, "Thunderbird" script, chrome, each nameplate requires (6) 375890-S barrel clips listed below to install (2 required) . . . . . COSB-6320978-A 44.95



1963 Door emblem, 3 per door, right requires (4) 373503-S pal nuts listed below to install (3 required) . . . . . C3SZ-6320980-R 18.95

1963 Door emblem, 3 per door, left, requires (4) 373503-S pal nuts listed below to install (3 required) . . . . . C3SZ-6320981-L 18.95



1963 Door emblem pal nut . . . . . 373503-S 0.50  
58-60 Barrel clip (as required) . . . . . 375890-S 0.60





## Roof Side Emblems, Inserts & Bezels



- 1958 Roof side emblem, plastic insert, black (2 required) . . . . . B8S-6350270-I 26.95
- 1958 Roof side emblem & bezel chrome with black insert, right . . . . . B8S-6350271-R 49.95
- 1958 Roof side emblem & bezel, chrome with black insert, left. . . B8S-6350270-L 49.95



- 1959 Roof side emblem, chrome with red & light aqua accents, each requires (3) 375480-S listed in next column (2 required) . . . . . B9S-6350270-A 39.95
- 1960 Roof side emblem, each requires (3) 375480-S listed in next column (2 required) . . . . . COSB-6350286-A 37.95



- 61-63 Roof side emblem insert, plastic, silver, black & turquoise, **except** Landau, fits C1SZ-63517A08-A bezel below (2 required) . . . . . C1SB-63517A20-C 18.95



- 61-63 Roof side emblem bezel, chrome, **except** Landau, each requires (3) 375480-S listed in next column (2 required) . . . . . C1SZ-63517A08-A 36.95



- 62-63 Roof side emblem, plastic insert, white, for Landau bar only (2 required) . . . . . C2SZ-63517A20-B 26.95
- 62-63 Roof side emblem, plastic insert, black, for Landau bar only (2 required) . . . . . B8S-6350270-I 26.95



- 1964 Roof side emblem, **except** Landau, chrome, each requires (3) 375480-S listed in next column (2 required) . . . . . C4SZ-63517A18-A 41.95



- 1965 Roof side emblem, **except** Landau, chrome, each requires (3) 375480-S listed in next column (2 required) . . . . . C5SZ-63517A18-A 41.95



- 1966 Roof side emblem, **except** Landau, chrome, each requires (3) 375480-S listed below (2 required) . . . C6SZ-63517A18-B 41.95
- 1966 Roof side emblem insert, silver bird on argent background, for Landau bar (2 required) (not shown) . . . C6SZ-63517A20-A 26.95



- 59-66 Roof side emblem clip (as required) . . . 375480-S 0.75

## Body Side Individual Mouldings

*We are proud to offer individual pieces for your convenience. When just the gas door moulding is missing, we can supply you with a replacement. The same goes for a door, a fender or a quarter panel moulding. Precisely manufactured in gleaming stainless steel, these mouldings will outlast your car. Give us a call & we'll get your order on its way!*

- 61-62 Door moulding, 50-7/8" long, right or left, includes clips (2 required) . . . . . C2SZ-6320878-A 51.95
- 61-62 Quarter moulding, 44-5/8" long, right or left, includes clips (2 required) . . . . . C2SZ-6329038-A 46.95
- 1962 Front fender moulding, 21-5/16" long, right or left, includes clips (2 required) . . . . . C2SZ-16003-A 31.95
- 1962 Quarter moulding bar, 1.88" long, die cast chrome, fits between quarter panel ornaments (4 required) . . . . . C2SZ-6329038-B 12.95
- 1964 Front fender moulding, 21-5/16" long, right or left, includes clips (2 required) . . . . . C2SZ-16003-A 31.95
- 64-66 Door moulding, 51-5/8" long, right or left, includes clips (2 required) . . . . . C4SZ-6320938-A 51.95
- 64-66 Quarter moulding, 78-3/4" long, right, includes clips . . . . . C4SZ-6329038-A 77.95
- 64-66 Quarter moulding, 47-7/8" long, left, includes clips . . . . . C4SZ-6329077-A 46.95
- 64-66 Gas door moulding, 6-1/2" long, left, includes clips . . . . . C4SZ-63405A48-A 20.95
- 64-66 Quarter moulding, 24-1/8" long, left, includes clips . . . . . C4SZ-6329039-A 31.95
- 1965 Front fender moulding, 14-3/8" long, right or left, includes clips (2 required) . . . . . C5SZ-16003-B 31.95
- 1966 Front fender moulding, 21-5/16" long, right or left, includes clips (2 required) . . . . . C2SZ-16003-A 31.95

## Center Tail Light Emblem

*At last, the final piece of chrome for your '66. This chromed Bird for the center of your tail light is a beauty.*



- 1966 Chrome bird with surround . . . . . C6SZ-13616-AR 49.95



*Rust is common in the floors & the lower body of all the '58 thru '66 Thunderbirds. MAC's patch panels are stamped from 19 to 20 gauge cold-rolled steel, unless noted otherwise.*

*We stock a large variety of patch panels to help make that Bird beautiful again, so call us & place your order today!*

**Painted or otherwise modified sheet metal is not returnable regardless of the reason.**

**Front Fender Lower Rear Patch Panels**



*The 1958-1960 front fender lower rear patch panel goes from the front door edge almost to the center of the wheel-well opening & measuring from the bottom up about 25 inches.*



- 58-60 Lower rear, right (shown) . . . . . B8S-16005-R 87.95
- 58-60 Lower rear, left . . . . . B8S-16006-L 87.95



- 61-63 Lower rear, right (shown) . . . . . C1SZ-16005-R 96.95
- 61-63 Lower rear, left . . . . . C1SZ-16006-L 96.95



- 64-66 Lower rear, right (shown) . . . . . C4SZ-16005-R 88.95
- 64-66 Lower rear, left . . . . . C4SZ-16006-L 88.95

**Splash Shields**

- 58-60 At rear of right front fender . . . . . B8S-16102-A 106.95
- 58-60 At rear of left front fender . . . . . B8S-16103-A 106.95
- 58-60 Seal set, 4-piece set does both sides . . . . . B8S-16170-ST 11.95 set

**Fender Apron Grommet (as required)**

- 58-60 Grommet, inner fender apron . . . . . B8S-14651 3.95

**Battery Box Apron Patch Panels**

*The battery box apron patch panel is designed to repair the front fender apron under the battery box where standing water & battery acid combine to rust away the sheet metal & leave your battery hanging. The nut plates for mounting the battery tray are included.*



- 61-63 Battery box apron patch panel . . . . . C1SZ-16054-A 136.95
- 64-66 Battery box apron patch panel . . . . . C4SZ-16054-A 136.95

**Rocker Panels**



**OS** *All rocker panels are oversized & require additional shipping charges.*



- 58-60 Right . . . . . B8S-6310128-R 50.95
- 58-60 Left . . . . . B8S-6310129-L 50.95
- 58-60 Right, extends back to wheel opening (shown) . . . . . B8S-6310128-RX 55.95
- 58-60 Left, extends back to wheel opening . . . . . B8S-6310129-LX 55.95



- 61-63 Right (shown) . . . . . C1SZ-6310128-R 112.95
- 61-63 Left . . . . . C1SZ-6310129-L 112.95

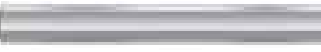

- 64-66 Right (shown) . . . . . C4SZ-6310128-R 112.95
- 64-66 Left . . . . . C4SZ-6310129-L 112.95

**Sheet Metal Supplies**



**Metal Primer (as required)**

- ALL Brown, use for big or small jobs, 12oz. spray can, . . . . . RSP1 \* 5.95

**Aluminum Metal Primer (as required)**

- ALL Green, zinc chromate, 12 oz. spray can . . . RSP3 \* 7.95

**Cold Galvanizing (as required)**

- ALL Provides durable film with over 90% zinc. Bonds to bare metal for a durable finish. 15 oz. spray can . . . . . RSP4 \* 8.95

*\* HAZARDOUS MATERIAL can only be shipped by ground/ surface within the U.S. because of government regulations.*

# BODY PARTS



Great care is taken to stamp out our floor pans so that they will look like the original floor. They are correctly shaped & have stiffening grooves that match the originals. If you can see the road passing by under your feet, you need to call us now so you can get started on the repairs.



The 1958-1960 front floor pans repair the area under the driver & front seat passenger's feet. The panels extend 3" up the firewall & back to the front seat. These beauties are stamped with the correct stiffening grooves, like the originals.

## Front & Rear Floor Pans



- 58-60 Front, right (shown) . . . . . B8S-6311135-RF 120.95
- 58-60 Front, left . . . . . B8S-6311135-LF 120.95
- 58-60 Rear, right . . . . . B8S-6311135-RR 120.95
- 58-60 Rear, left . . . . . B8S-6311135-LR 120.95

The 1961-1966 front floor pans repair the area under the driver & front seat passenger's feet. The panels extend 5" up the firewall & are stamped with stiffening grooves like the originals.



- 61-63 Front, right (shown) . . . . . C1SZ-6311135-RF 144.95
- 61-63 Front, left . . . . . C1SZ-6311135-LF 144.95



- 64-66 **OS** Front, right (shown) . . . C4SZ-6311135-RF 144.95
- 64-66 **OS** Front, left . . . . . C4SZ-6311135-LF 144.95

The 1961-1966 rear floor pans repair the area of the floor between the front & the rear seat from the inner rocker panel to the transmission tunnel. They are stamped with the correct stiffening grooves like the originals.

- 61-63 **OS** Rear, right . . . . . C1SZ-6311135-RR 144.95
- 61-63 **OS** Rear, left . . . . . C1SZ-6311135-LR 144.95



- 64-66 Rear, right (shown) . . . . . C4SZ-6311135-RR 144.95
- 64-66 Rear, left . . . . . C4SZ-6311135-LR 144.95

## Floor Pan Cover Plate



- 64-66 **NEW** (10 required) . . . . . C7AZ-6211137-A 1.95

## Drain Valves (2 required)



- 63-66 For rear floor pan extension . . . C3AZ-6211202-A 14.95
- 64-66 For rocker panel . . . . . C4AZ-62103A58-C 4.95 pair

## Floor Pan Plug (as required)



- 61-63 Rubber, 1-1/4" . . . . . 352284-S 1.95

## Quarter Panel Extensions

- 58-60 Right . . . . . B8S-6329246-R 114.95
- 58-60 Left . . . . . B8S-6329247-L 114.95

## Trunk Floor Parts

Rear trunk floor extensions repair the outer wheelhouse at the rear & run from the bottom rear of the quarter panel to the trunk floor.

**Patch panels are stamped from 19 to 20 gauge cold-rolled steel. Painted or otherwise modified sheet metal is not returnable regardless of the reason.**

### Patch Panels

- 58-59 For fuel tank sending unit access, stamped steel . . . . . B5A-7011290 10.95
- 58-60 Center, 20-5/8" x 24-1/2" . . . . . B8S-6311215-C 160.95
- 58-60 Right . . . . . B8S-6311215-R 200.95
- 58-60 Left . . . . . B8S-6311215-L 200.95

1964-1966 Trunk Floor Sheet Metal  
Center Floor Pan Patch Panel  
C4SZ-6311215-C

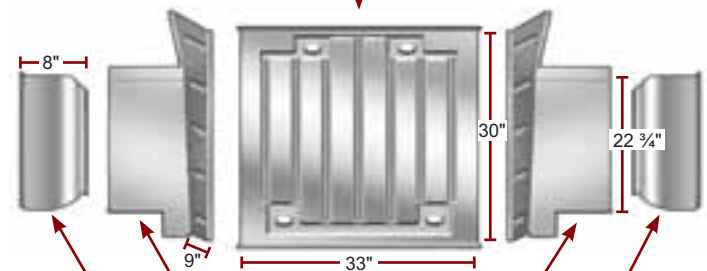

Side Patch Panels  
C4SZ-6311215-L C4SZ-6311215-R

Trunk Floor Over Muffler Panels  
(listed on next page)

C4SZ-6311253-L C4SZ-6311252-R

- 64-66 Pan, center, 30" x 33" . . . . . C4SZ-6311215-C 375.95
- 64-66 Pan, right . . . . . C4SZ-6311215-R 160.95
- 64-66 Pan, left . . . . . C4SZ-6311215-L 160.95





Trunk Floor Over Muffler



- 61-63 Right (shown) . . . . . C1SB-6311252-R 240.95
- 61-63 Left . . . . . C1SB-6311253-L 240.95

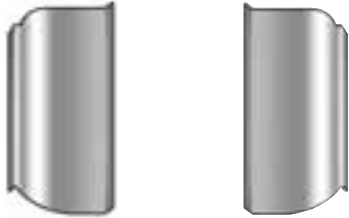

- 64-66 Right, 8" x 22-3/4" . . . . . C4SZ-6311252-R 104.95
- 64-66 Left, 8" x 22-3/4" . . . . . C4SZ-6311253-L 104.95

Trunk Floor Extensions



- 58-60 Right (shown) . . . . . B8S-6311250-R 120.95
- 58-60 Left . . . . . B8S-6311251-L 120.95



- 61-63 Right (shown) . . . . . C3SZ-6311250-R 120.95
- 61-63 Left . . . . . C3SZ-6311251-L 120.95



- 64-66 Right (shown) . . . . . C4SZ-6311250-R 128.95
- 64-66 Left . . . . . C4SZ-6311251-L 128.95

Doorskin Patch Panels

These patch panels repair the lower 5-1/2" of the doors & include the end flanges to fold over.



- 64-66 Lower, right (shown) . . . . . C4SZ-6320200-R 80.95
- 64-66 Lower, left . . . . . C4SZ-6320201-L 80.95

Wheelhouse Patch Panels

The lower front wheelhouse repairs the bottom front of the outer wheelhouse.



- 61-63 Lower front, right (shown) . . . . . C1SZ-6327894-R 64.95
- 61-63 Lower front, left . . . . . C1SZ-6327895-L 64.95

The outer wheelhouse top cap patch panel repairs the area where the outer wheelhouse meets the quarter. This panel is about 4" wide & runs from the bottom front of the wheelhouse, over the top of the wheelhouse & stops where it meets the rear wheelhouse extension.



- 64-66 Outer wheelhouse top cap patch panel, right (shown) . . . C4SZ-6327894-R 88.95
- 64-66 Outer wheelhouse top cap patch panel, left . . . . . C4SZ-6327895-L 88.95

Fender Skirt, Seals & Pins

C1SZ-7327986-PR

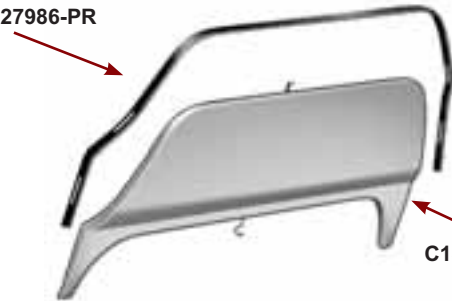

C1SZ-6327974-PR

- 61-63 Skirt, right & left sides, includes all hardware, vinyl skirt seals are attached, sold as a pair only (shown) . . . . . C1SZ-6327974-PR 512.95 pair
- 58-60 Seals, rubber . . . . . B8S-7327986-PR 13.95 pair
- 61-63 Seals, rubber (shown) . . . . . C1SZ-7327986-PR 22.95 pair
- 61-66 Seals, economy style, not die cut . . . C1SZ-7327986 12.95 pair
- 64-66 Seals, die-cut rubber . . . . . C4SZ-7327986-PR 19.95 pair
- 58-66 Staple kit for skirt seals, 20 pieces . . . . . 27986-KT 2.95 kit
- 58-66 Pins, these are inserted thru holes in the wheel lip & help to locate the skirts in their correct position (as required) . . . . . 370034-S8B 2.95



## Quarter Patch Panels

All patch panels have to be welded onto your car. Most will require some reshaping to assure a good fit. This kind of work is best left to experienced shops to achieve the best results.

### Lower Rear



- 58-60 **OS** Right, 65" long x 18" high, long enough to overlap front patch panel listed below (shown) . . . . . 27840-50764-R 117.95
- 58-60 **OS** Left, 65" long x 18" high, long enough to overlap front patch panel listed below . . . . . 27841-50764-L 117.95
- 64-66 Right, 40" long x 8-1/2" high . . . . . 27840-52750-R 192.95
- 64-66 Left, 40" long x 8-1/2" high . . . . . 27841-52750-L 192.95

### Lower Front



- 58-60 Right, 33" long x 20" high, long enough to overlap rear patch panel listed above (shown) . . . . . 27840-50767-R 95.95
- 58-60 Left, 33" long x 20" high, long enough to overlap rear patch panel listed above . . . . . 27841-50767-L 95.95



- 61-63 Right (shown) . . . . . 27840-52725-R 120.95
- 61-63 Left . . . . . 27841-52725-L 120.95



- 64-66 Right (shown) . . . . . 27840-52759-R 120.95
- 64-66 Left . . . . . 27841-52759-L 120.95

### Half-Height



- 61-63 Lower, right, 81" long x 20" high, too big for U.P.S. -see note below (shown) . . . . . 27840-52724-R 374.95
- 61-63 Lower, left, 81" long x 20" high, too big for U.P.S., see note below . . . . . 27841-52724-L 374.95



- 64-66 Lower, right, 80" long x 22" high, too big for U.P.S. -see note below (shown) . . . . . 27840-52757-R 364.95
- 64-66 Lower, left, 80" long x 22" high, too big for U.P.S. -see note below . . . . . 27841-52757-L 364.95

### Full Height



- 64-66 Right (shown) . . . . . 27840-52758-R 406.95
- 64-66 Left . . . . . 27841-52758-L 406.95

Average charges are \$100.00 & high charges could be \$125.00 or more. Trucking companies also charge approximately \$25.00 for a residential delivery & approximately \$25.00 to notify you by telephone, if you request notification.

## Upper Rear Deck Panel



- 61-63 **OS** Upper rear deck panel, located between rear glass & the deck lid, coupe . . . . . C1SZ-6340310-C 227.95

## Sheet Metal Supplies

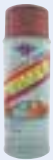

### Metal Primer (as required)

- ALL Brown, use for big or small jobs, 12oz. spray can, . . . . .RSP1 \* 5.95

### Aluminum Metal Primer (as required)

- ALL Green, zinc chromate, 12 oz. spray can . . .RSP3 \* 7.95

### Cold Galvanizing (as required)

- ALL Provides durable film with over 90% zinc. Bonds to bare metal for a durable finish. 15 oz. spray can . . . . .RSP4 \* 8.95

\* **HAZARDOUS MATERIAL** can only be shipped by ground/ surface within the U.S. because of government regulations.



**Tires**

**OS** All tires are oversized & require additional shipping charges.

1958-1960: 8.00 x 14" (converts to G78 x 14") with 2-1/4" wide whitewall or 8.50 x 14" (converts to H78 x 14") with 2-1/4" wide whitewall.

1961: 8.00 x 14" (converts to G78 x 14") with 1" or 2" wide whitewall.

1962-1963: 8.00 x 14" (converts to G78 x 14") with 1" whitewall.

1964 WITH WIRE WHEELS: 8.00 x 14" (converts to G78 x 14") with 1" whitewall.

1964 WITHOUT WIRE WHEELS: 8.15 x 15" (converts to G78 x 15") with 1" whitewall.

1965-1966: 8.15 x 15" (converts to G78 x 15") with 1" whitewall, with or without red line.



Blackwall tires were standard equipment from 1958-1966.

**TIRE SHIPPING NOTE:**

If tires must be shipped to MAC's, there will be an additional charge of \$15.00 per tire to cover shipping expenses. This applies to any Alaska, Hawaii, Puerto Rico, Foreign, COD or walk-in order. There will be no exceptions.

**14" Whitewall Tires**

When ordering four tires for your car, don't forget to order one more for your spare.

58-60	8.00 x 14", 2-1/4" whitewall, Goodyear Custom Super Cushion	14WGF	192.95
58-60	8.00 x 14", 2-1/4" whitewall, BF Goodrich	14WBK	157.95
58-60	8.00 x 14", 2-1/4" whitewall, Universal	14WUD	129.95
58-60	G78 x 14", 2-1/4" whitewall, Coker Classic	14WKC	113.95
61-64	8.00 x 14", 1" whitewall, Goodyear Custom Super Cushion	14WGE	184.95
61-64	8.00 x 14", 1" whitewall, BF Goodrich	14WBL	157.95
61-64	8.00 x 14", 1" whitewall, Universal	14WUC	129.95
58-64	G78 x 14", dual 3/8" whitewall, BF Goodrich	14DWBA	148.95

**15" Whitewall Tires**

64-66	8.15 x 15", 1" whitewall, BF Goodrich	15WBL	180.95
65-66	8.15 x 15", 1" whitewall with a 3/8" red line, BF Goodrich	15RGA	180.95







## Interior Screw Kits



**Why mess with old, beat-up, rusty, mis-matched bolts, nuts & screws when you can buy a kit that has all of the fasteners you're going to need? For slightly more than 60 bucks, you'll get all the screws for your interior in one package. Call us, we'll be happy to send out your kit right away!**

*Included are all new correct fasteners for your interior. Lengths might vary, but the head size & type is the same as original.*

### Convertible

1958	.....2HK90A	60.95 kit
1959	.....2HK90C	60.95 kit
1960	.....2HK90E	60.95 kit
1961	.....2HK90G	60.95 kit
1962	.....2HK90J	60.95 kit
1963	.....2HK90L	60.95 kit
1964	.....2HK90N	60.95 kit
1965	.....2HK90R	60.95 kit
1966	.....2HK90T	60.95 kit

### Hardtop

1958	.....2HK90B	60.95 kit
1959	.....2HK90D	60.95 kit
1960	.....2HK90F	60.95 kit
1961	.....2HK90H	60.95 kit
1962	.....2HK90K	60.95 kit
1963	.....2HK90M	60.95 kit
1964	.....2HK90P	60.95 kit
1965	.....2HK90S	60.95 kit
1966	.....2HK90U	60.95 kit

## Steering Column Hardware

61-63	Steering wheel side boot installation set, 4 pan-head Phillips screws.....	2HK9A	2.95 set
-------	----------------------------------------------------------------------------	-------	----------

## Radiator & Grille Hardware

58-60	Grille spring clip (7 required).....	B8S-17763-A	7.95
61-63	Radiator cover hardware kit, 3 faceted-flange-head black oxide finish bolts, 7 hex head bolts & 10 flat washers.....	2HK28A	6.95 kit
61-63	Grille guard mounting hardware set, 2 hex nuts & 2 flat washers.....	2HK28G	2.95 set
61-63	Seal support hardware kit, radiator to hood, 2 black oxide finish hex faceted-flange-head bolts & 2 flat washers.....	2HK28C	3.95 kit
61-66	Retainer nut, 5/16"-24, for fan shroud on cars with A/C (as required).....	359952-S2	2.95
62-63	Staples for radiator air baffle, 12-piece kit.....	2HK28N	1.95 kit
1963	Grille mounting hardware kit, 10 hex washer-head bolts (black oxide finish) & 10 black oxide finish clips with captive nuts.....	2HK28D	15.95 kit
64-65	Grille mounting hardware kit, 10 hex head bolts with captive flat washers (black oxide finish) & 10 threaded "U" nuts (black oxide finish).....	2HK28E	16.95 kit
64-66	Radiator shield hardware kit, 4 black oxide finish bolts with captive flat washers, 4 external-tooth lock-washers & 7 black oxide finish threaded "U" nuts (5 large & 2 small) & 5 faceted-flange-head black oxide finish bolts.....	2HK28B	14.95 kit
1966	Grille mounting hardware kit, 2 pan-head Phillips screws, 2 external-tooth lock-washers, 2 faceted-flange-head black oxide finish bolts, 4 faceted-flange black oxide finish lock-nuts, 10 threaded "U" nuts & 18 hex head black oxide finish bolts with captive flat washers.....	2HK28F	30.95 kit

1966	Top grille moulding hardware kit, 6 spring-type "U" nuts & 6 washer-head Phillips screws, 1 kit does both sides.....	2HK28H	5.95 kit
1966	Grille moulding under headlight ("eyebrow") hardware kit, 2 pan-head Phillips screws & 6 barrel clips, 1 kit does both sides.....	2HK28J	6.95 kit
1966	Grille moulding center clip hardware set, 2 flat-top round washer-head Phillips screws & 2 spring-type "U" nuts.....	2HK28K	2.95 set
1966	Complete grille moulding hardware kit, 8 flat-top roundwasher-head Phillips screws, 8 spring-type "U" nuts, 2 pan-head Phillips screws, 3 hex nuts with captive lock-washers & 6 blind nuts.....	2HK28L	17.95 kit
1966	Grille center ornament hardware set, 3 hex nuts with captive external-tooth lock-washers.....	2HK28M	2.95 set

## License Plate Bracket Hardware

64-66	Rear license plate holder screw & nut set, 2 slotted pan-head screws & 2 plastic license plate nuts.....	2HK13A	3.95 set
1966	Front license plate bracket bolt set, 2 hex head bolts with captive flat washers, black oxide finish.....	2HK13E	2.95 set

## Air Cleaner Wing Nut

61-63	Cadmium plated like original.....	2HK33A	2.95
-------	-----------------------------------	--------	------

## Battery Hardware

61-63	3 faceted-flange-head black oxide finish bolts.....	2HK36A	5.95 kit
64-66	4 faceted-flange-head bolts & 4 faceted-flange lock-nuts black oxide finish.....	2HK36B	7.95 kit
1966	3 hex washer-head bolts & 3 faceted-flange lock-nuts black oxide finish.....	2HK36C	5.95 kit

## Dash Hardware

61-63	Dash end cap mounting hardware kit, 8 oval-head Phillips screws, 1 kit does both sides.....	2HK45A	3.95 kit
61-63	Instrument bezel cover screw set, 3 oval-head Phillips screws.....	2HK45B	2.95 set
64-66	Instrument housing bezel installation kit, 4 large oval-head Phillips screws, 4 medium oval-head Phillips screws & 7 small oval-head Phillips screws.....	2HK45C	5.95 kit
64-66	Instrument housing retainer plate screw set, 6 oval-head Phillips screws, black oxide finish.....	2HK45D	3.95 set
64-66	Radio speaker grille hardware set, 2 oval-head Phillips screws, black oxide finish.....	2HK65A	2.95 set
64-66	Lower dash trim screw set, 3 oval-head Phillips screws (2 short/1 longer), left.....	2HK45E	2.95 set
64-66	Lower dash trim screw set, 3 flat-head Phillips screws, right.....	2HK45F	2.95 set
61-63	Air conditioning vent in console screw set, 3 pan-head Phillips screws.....	2HK45G	3.95 set

## Radio Hardware

64-66	Radio speaker grille hardware set, 2 oval-head Phillips screws, black oxide finish.....	2HK65A	2.95 set
-------	-----------------------------------------------------------------------------------------	--------	----------

## Headlight Door Hardware

61-63	Headlight door screw set, 4 oval-head Phillips type.....	2HK40D	2.95 set
64-65	Headlight door hardware kit, 6 oval-head Phillips screws & 6 black oxide finish, spring type U-nuts.....	2HK40E	5.95 kit
1966	Headlight door hardware kit, 4 oval-head Phillips screws & 4 black oxide finish, spring type U-nuts.....	2HK40G	6.95 kit



**Headlight Hardware**

- 61-63 Headlight bucket hardware set,  
4 hex washer-head bolts,  
black oxide finish, 1 set per car . . . . . 2HK40A 4.95 set
- 64-65 Headlight bucket hardware kit, contains  
4 each of: hex washer-head screws,  
black oxide finish spring-type "J" clips,  
hex nuts & flat washers, 1 kit does  
both sides . . . . . 2HK40B 6.95 kit
- 1966 Headlight bucket hardware kit, 4 hex-head bolts,  
4 flat washers, 2 faceted flange-head black  
oxide finish bolts, 2 black oxide finish  
faceted-flange lock-nuts & 6 threaded  
"U" nuts, 1 kit does both sides . . . . . 2HK40C 11.95 kit

**Console Hardware**

- 61-63 Console upper trim hardware set,  
6 oval-head Phillips screws & 3 large trim  
clips, 1 set does both sides. . . . . 2HK45H 5.95 set
- 61-63 Console side piece screw set, 10 oval-head  
Phillips screws, does both sides . . . . . 2HK45J 4.95 set
- 61-63 Console ashtray screw set, 4 oval-head  
Phillips screws. . . . . 2HK45K 2.95 set
- 61-63 Console ashtray cover handle screw set,  
2 pan-head Phillips screws . . . . . 2HK45L 2.95 set
- 64-66 Console power window switch retainer  
screw kit, 8 black oxide finish oval-head  
Phillips screws. . . . . 2HK45N 3.95 kit
- 64-66 Console lower moulding screw kit,  
10 oval-head Phillips screws,  
does both sides. . . . . 2HK45P 5.95 kit
- 64-66 Console storage bin hardware set,  
5 round washer-head Phillips screws,  
black oxide finish. . . . . 2HK45R 2.95 set
- 64-66 Casting around console storage bin  
hardware set, 4 hex nuts with captive  
flat washers, black oxide finish . . . . . 2HK45S 3.95 set
- 64-66 Console storage bin lid check strap screw set,  
2 hex washer-head screws . . . . . 2HK45T 2.95 set
- 64-66 Console storage bin lid catch screw set,  
2 hex washer-head screws . . . . . 2HK45U 2.95 set
- 64-66 Console cigar lighter & ashtray case  
hardware kit, 4 slotted hex washer-head  
screws, 2 oval-head Phillips screws &  
4 external-tooth lock-washers . . . . . 2HK45V 2.95 kit
- 64-66 Console storage bin lid hinge hardware set,  
2 each of hex washer-head screws,  
2 flat washers, 2 external lock-washers  
& 2 faceted-flange lock-nuts  
(black oxide finish) . . . . . 2HK45W 3.95 set
- 64-66 Console storage bin lid latch hardware set,  
4 slotted hex washer-head screws  
& 4 external-tooth lock-washers . . . . . 2HK45X 2.95 set
- 64-66 Rear console ashtray retainer screw set,  
3 pan-head Phillips screws . . . . . 2HK45Y 2.95 set

**Ashtray & Lighter Hardware**

- 61-63 Console ashtray screw set, 4 oval-head  
Phillips screws. . . . . 2HK45K 2.95 set
- 61-63 Console ashtray cover handle screw set,  
2 pan-head Phillips screws . . . . . 2HK45L 2.95 set
- 64-66 Console cigar lighter & ashtray case  
hardware kit, 4 slotted hex washer-head  
screws, 2 oval-head Phillips screws &  
4 external-tooth lock-washers . . . . . 2HK45V 2.95 kit
- 64-66 Rear console ashtray retainer screw set,  
3 pan-head Phillips screws . . . . . 2HK45Y 2.95 set

**Air Conditioner Hardware**

- 61-63 Air conditioner vent in console screw set,  
3 pan-head Phillips screws . . . . . 2HK45G 3.95 set

**Wiring Hardware**



- 61-63 Engine compartment wire loom fastener set, 8 round  
black plastic clamps & 8 hex washer-head screws,  
for left side of engine compartment . . . 2HK48A 8.95 set
- 64-66 Engine compartment wire loom fastener set, 16 round  
black plastic clamps & 16 hex washer-head  
screws . . . . . 2HK48B 14.95 set
- 61-63 Door wiring shield screw set, 4 hex washer-head  
screws, enough for both sides . . . . . 2HK74E 2.95 set
- 64-66 Door wiring shield screw set, 4 hex washer-head  
screws, enough for both sides . . . . . 2HK74F 2.95 set



- 58-66 Engine compartment wiring harness strap,  
black plastic, adjustable (as required) . 376914-S 0.95

**Bumper Hardware**

- 61-63 Rear bumper hardware kit, contains 6 each:  
black oxide finish faceted-flange lock-nuts,  
lock-washers, flat washers, bumper bolts  
& hex-head bolts . . . . . 2HK59A 33.95 kit
- 64-66 Rear bumper hardware kit, 4 external-tooth  
lock-washers, 8 lock-washers, 8 acorn nuts,  
4 faceted-flange-head black oxide  
finish bolts, 8 flat washers, 8 hex nuts &  
8 bumper bolts . . . . . 2HK59B 21.95 kit
- 61-63 Rear bumper "Q" seal hardware kit,  
10 hex-head bolts, 10 lock-washers &  
10 flat washers, 1 kit does both sides. . 2HK59C 8.95 kit
- 64-66 Rear bumper support hardware kit,  
8 faceted-flange-head black oxide finish  
bolts & 8 external-tooth lock-washers,  
1 kit does both sides. . . . . 2HK59D 11.95 kit
- 64-66 Rear bumper center bolt set, 4 black oxide  
finish bolts with captive flat washers. . . 2HK59E 5.95 set
- 64-66 Rear bumper bracket to frame hardware kit,  
contains 4 each: flat washers,  
hex-head bolts & lock-washers,  
1 kit does both sides. . . . . 2HK59F 7.95 kit
- 61-63 Front bumper hardware kit, 6 black oxide  
finish faceted-flange lock-nuts,  
8 flat washers, 2 lock-washers,  
2 hex-head bolts & 6 bumper bolts. . . 2HK59G 29.95 kit
- 64-66 Front bumper hardware kit, 14 flat washers,  
12 lock-washers, 12 hex-head bolts &  
12 faceted-flange-head black oxide  
finish bolts . . . . . 2HK59H 26.95 kit
- 61-63 Front bumper extension hardware set,  
2 hex-head bolts & 2 hex nuts with  
captive washers . . . . . 2HK59J 3.95 set
- 64-65 Front bumper guard hardware kit, 2 hex nuts,  
2 bumper bolts, 2 hex-head bolts,  
2 lock-washers & 4 flat washers . . . . . 2HK59K 11.95 kit
- 64-65 Front bumper bracket to frame hardware kit,  
8 each: hex-head bolts, lock-washers &  
flat washers, 1 kit does both sides . . . 2HK59L 10.95 kit
- 1966 Front bumper installation kit, 12 hex-head bolts,  
8 flat washers & 12 lock-washers,  
1 kit does both sides. . . . . 2HK59M 14.95 kit



## Cowl Vent Hardware

61-63	Front air vent bracket hardware set, 2 each of large hex washer-head bolts (black oxide finish), smaller hex washer-head bolts (black oxide finish) & hex nuts with captive lock-washers, 1 set does both sides . . . . .	2HK67A	4.95 set
61-63	Cowl cover hardware set, 10 slotted hex washer-head screws, 10 external-tooth lock-washers & 4 round-head Phillips screws . . . . .	2HK67B	5.95 set
64-66	Cowl cover hardware set, 10 hexagon washer-head screws, 10 internal/external tooth lock-washers & 2 pan-head Phillips screws . . . . .	2HK67C	5.95 set



**Stamped Nut**

61-63	Hood grille to bezel hardware set, 3 stamped nuts (1 notch) . . . . .	2HK54F	2.95 set
61-63	Hood guide latch hardware kit, 8 faceted-flange-head black oxide finish bolts & 8 flat washers . . . . .	2HK54H	10.95 kit
61-63	Hood guide latch on hood hardware set, 2 faceted-flange-head black oxide finish bolts & 2 flat washers . . . . .	2HK54J	3.95 set
61-63	Hood catch hardware kit, 3 faceted-flange-head black oxide finish bolts & 3 flat washers . . . . .	2HK54M	4.95 kit
61-63	Hood release bar hardware kit, contains 2 each: hex-head bolts, faceted-flange head black oxide finish bolts, flat washers, internal/external-tooth lock-washers & clips with captive nuts . . . . .	2HK54R	6.95 kit
64-65	Hood latch hardware set, 2 faceted-flange-head bolts, black oxide finish . . . . .	2HK54K	3.95 set
64-65	Hood catch hardware kit, 4 faceted-flange-head black oxide finish bolts & 4 flat washers . . . . .	2HK54N	5.95 kit
64-66	Hood hinge to hood hardware kit, 4 hex washer-head black oxide finish bolts & 4 external-tooth lock-washers, 1 kit does both sides . . . . .	2HK54B	5.95 kit
64-66	Hood hinge to inner fender brace hardware kit, 6 hex-head bolts with captive flat washers, black oxide finish, 1 kit does both sides . . . . .	2HK54D	7.95 kit
1966	Hood center ornament hardware set, 5 stamped nuts (1 notch) . . . . .	2HK54G	2.95 set
1966	Hood latch hardware set, 3 hex-head bolts with captive flat washers . . . . .	2HK54L	3.95 set
1966	Hood catch hardware set, 2 faceted-flange-head black oxide finish bolts & 2 external-tooth lock-washers . . . . .	2HK54P	3.95 set

## Mirror Hardware

1963	Remote rear-view mirror to body screw set, 2 oval-head Phillips screws, 1 set per mirror . . . . .	2HK74N	2.95 set
1964	Outside rear-view mirror screw set, 2 oval-head Phillips screws, early 1964 only (2 sets required) . . . . .	2HK74P	2.95 set
64-66	Outside rear-view mirror screw set, 2 pan-head Phillips screws, left hand mirror only, from mid-1964 . . . . .	2HK74R	2.95 set

## Fender Hardware

61-63	Export brace hardware kit, firewall to shock tower, 8 unfinished steel bolts, 10 faceted-flange lock-nuts & 8 flat washers, 1 kit does both sides . . . . .	2HK52A	14.95 kit
64-66	Export brace hardware kit, 6 hex nuts, 6 lock-washers, 8 black oxide finish faceted-flange lock-nuts & 8 black oxide finish hex-head bolts with captive flat washers . . . . .	2HK52B	14.95 kit
61-63	Vacuum storage tank bracket hardware set, 2 hex-head screws . . . . .	2HK52C	2.95 set
61-63	Fender hardware kit, complete kit: 4 faceted-flange lock-nuts, 16 flat washers, 21 faceted-flange-head black oxide finish bolts, 15 black oxide finish hex-head bolts with captive flat washers & 16 black oxide finish threaded "U" nuts, 1 kit does both sides . . . . .	2HK52D	68.95 kit
61-63	Fender bolt set, 8 faceted-flange-head black oxide finish bolts & 8 flat washers, 1 set does 1 fender (2 sets required) . . . . .	2HK52E	10.95 set
64-66	Fender hardware kit, 8 threaded "U" nuts, 8 hex-head bolts with captive flat washers & 2 hex washer-head screws, 1 kit does 1 fender (2 kits required) . . . . .	2HK52F	21.95 kit
64-65	Fender splash shield rear hardware kit, 1 threaded "U" nut, 1 black oxide finish hex-head bolt with captive flat washer, 1 faceted-flange-head black oxide finish bolt, 1 external-tooth lock-washer, 1 hex washer-head bolt, 1 hex washer-head screw & 2 hex nuts, 1 kit does the rear of 1 splash shield (2 kits required) . . . . .	2HK52G	5.95 kit

## Hood Hardware

61-63	Hood hinge to hood hardware kit, 4 faceted-flange-head black oxide finish bolts & 4 flat washers, 1 kit does both sides . . . . .	2HK54A	5.95 kit
61-63	Hood hinge to inner fender brace hardware kit, 6 hex faceted-flange head black oxide finish bolts & 4 flat washers, 1 kit does both sides . . . . .	2HK54C	5.95 kit
61-63	Hood vent casting hardware kit, 10 hex washer-head bolts . . . . .	2HK54E	3.95 kit

## Door Seal Hardware

61-63	Quarter lock pillar upper front weatherstrip screw set, 4 pan-head Phillips screws, 1 set does both sides . . . . .	2HK73A	2.95 set
64-66	Quarter pillar seal at belt screw set, 8 oval-head Phillips screws, 1 set does both sides . . . . .	2HK73B	3.95 set
61-63	Door belt front cap screw set, 2 oval-head Phillips screws & 2 pan-head Phillips screws, 1 set does both sides . . . . .	2HK73C	2.95 set
61-63	Door belt rear cap screw set, 10 oval-head Phillips screws, 1 set does both sides . . . . .	2HK73S	5.95 set

## Door Hardware

61-63	Door hinge to door hardware kit, 4 hex washer-head bolts (black oxide finish) & 4 external-tooth lock-washers, 1 kit does both hinges on 1 door (2 kits required) . . . . .	2HK74A	6.95 kit
61-63	Door wiring shield screw set, 4 hex washer-head screws, 1 set does both sides . . . . .	2HK74E	2.95 set
61-63	Door scuff plate screw set, 18 oval-head Phillips screws, 1 set does both sides . . . . .	2HK74G	5.95 set
61-63	Striker plate screw set, 6 flat-head Phillips screws with captive lock-washers, 1 set is enough for both sides . . . . .	2HK74J	20.95 set
61-63	Door bumper hardware set, 2 pieces, 1 set does both doors . . . . .	2HK74S	7.95 set
1963	Remote rear-view mirror to body screw set, 2 oval-head Phillips screws, 1 set per mirror (2 sets required) . . . . .	2HK74N	2.95 set





- 1964 Outside rear-view mirror screw set, 2 oval-head Phillips screws, early 1964 only, 1 set per mirror . . . . . 2HK74P 2.95 set
- 64-66 Door hinge to door hardware kit, 6 hex washer-head bolts (black oxide finish) & 6 internal & external tooth lock-washers, 1 kit does both hinges on 1 door (2 kits required) . . . . . 2HK74B 13.95 kit
- 64-66 Door hinge to body hardware kit, 8 hex washer-head bolts (black oxide finish) & 8 external-tooth lock-washers, 1 kit does both hinges on 1 door (2 kits required) . . . . . 2HK74C 11.95 kit
- 64-66 Door flaps to fender screw kit, 12 hex washer-head screws, does both sides . 2HK74D 5.95 kit
- 64-66 Door wiring shield screw set, 4 hex washer-head screws, 1 set does both sides. . . . . 2HK74F 2.95 set
- 64-66 Door scuff plate screw set, 12 oval-head Phillips screws (8 long/4 short), 1 set is enough for both sides. . . . . 2HK74H 5.95 set
- 64-66 Striker plate screw set, 4 flat-head Phillips screws, 1 set does both sides. . . . . 2HK74K 6.95 set
- 64-66 Door latch installation screw set, 6 flat-head Phillips screws with captive lock-washers, 1 set does both sides . . . . . 2HK74M 5.95 set
- 64-66 Outside rear-view mirror screw set, 2 pan-head Phillips screws, left hand mirror only, from mid-1964 . . . . . 2HK74R 2.95 set

## Window Hardware

- 61-63 Window guide hardware set, 6 oval-head Phillips screws with captive external-tooth lock-washers, 1 set does both sides. . . 2HK77A 4.95 set
- 64-66 Console power window switch retainer screw kit, 8 black oxide finish oval-head Phillips screws. . . . . 2HK45N 3.95 kit

## Seat Hardware

- 61-63 Fiberglass side installation hardware set, 6 pan-head Phillips screws, 1 set does both front seats . . . . . 2HK79A 5.95 set
- 61-63 Seat hinge elbow screw set, 2 pan-head Phillips screws, 1 set does both sides . 2HK79B 2.95 set
- 1964 Front seatback panel installation set, 12 oval-head Phillips screws, 1 set does 2 seatbacks . . . . . 2HK91R 4.95 set
- 1965 Rear seat panel screw set, 4 oval-head Phillips screws, 1 set does 2 sides . . . . 2HK91S 2.95 set
- 64-66 Front seatback stop hardware set, 8 oval-head Phillips screws, does both seats. . . . . 2HK79C 3.95 set



- 63-66 **NEW Save** Plug set, 4 pieces, for front seat mounting holes, rubber, 1-1/2" x 23/64" . . . . . 377901-ST 6.95 set
- 63-66 Plug for front seat mounting holes, rubber, 1-1/2" x 23/64" (4 required). . . . . 377901-S 3.95

## Windshield Hardware

- 61-63 Upper corner of interior windshield screw set, 4 oval-head Phillips screws, coupe. . . 2HK80B 2.95 set
- 61-63 Upper corner of interior windshield cap screw set, 4 oval-head Phillips screws, convertible. . . . . 2HK80C 2.95 set
- 61-63 Upper interior windshield stainless steel moulding screw set, 3 oval-head Phillips screws, coupe & convertible. . . 2HK80E 2.95 set
- 61-63 Interior "A" pillar windshield trim screw set, 4 oval-head Phillips screws, 1 set does both sides, convertible . . . 2HK80G 2.95 set

- 61-63 Interior "A" pillar windshield trim screw set, 12 oval-head Phillips screws, 1 set does both sides, coupe . . . . . 2HK80J 3.95 set
- 61-63 Interior "A" pillar windshield trim screw set, 4 oval-head Phillips screws, 1 set does both sides, coupe . . . . . 2HK80K 2.95 set
- 61-63 Exterior "A" pillar windshield weatherstrip retainer screw set, 10 oval-head Phillips screws, 1 set does both sides, convertible. . . . . 2HK80H 3.95 set
- 61-63 Windshield rain gutter screw set, 6 oval-head Phillips screws, 1 set does both sides, convertible . . . 2HK80M 3.95 set
- 64-66 Top of exterior windshield chrome screw set, 3 oval-head Phillips screws, convertible. . . . . 2HK80A 2.95 set
- 64-66 Upper corner of interior windshield cap screw set, 2 oval-head Phillips screws, convertible. . . . . 2HK80D 2.95 set
- 64-66 Upper interior windshield moulding & visor bracket hardware kit, 12 oval-head Phillips screws & 2 external-tooth lock-washers . . . . . 2HK80F 5.95 kit
- 64-66 Windshield interior side post trim screw set, 2 oval-head Phillips screws, 1 set does both sides . . . . . 2HK80L 2.95 set
- 64-66 Windshield rain gutter installation hardware set, 8 flat-head Phillips screws, 1 set does both sides, convertible . . . 2HK80N 13.95 set

## Roof Hardware



- 58-66 **NEW** T-bolt for convertible roof rail seals (as required) . . . . . 35222-S 1.95
- 64-66 Roof rail weatherstrip screw set, 24 round washer-head screws, 1 set does both sides . . . . . 2HK81A 37.95 set
- 64-66 Coat hook installation set, 2 flat-head Phillips screws, 1 set does 2 coat hooks. . . . . 2HK81B 2.95 set

## Convertible Top Hardware

- 61-63 A-pillar seal retainer screw set, 4 oval-head Phillips screws, 1 set does both sides . . . . . 2HK82A 2.95 set

## Sheetmetal Hardware

- 1966 Front valance center hardware kit, 7 hex washer-head bolts (black oxide finish) & 7 black oxide finish threaded "U" nuts . . . . . 2HK88A 18.95 kit
- 1966 Front valance center bracket hardware kit, 2 hex washer-head bolts (black oxide finish) & 2 threaded "U" nuts (black oxide finish) . . . . . 2HK88B 4.95 kit
- 1966 Front valance side hardware kit, 14 black oxide finish threaded "U" nuts & 14 faceted-flange-head black oxide finish bolts, 1 kit does both sides . . . . 2HK88C 35.95 kit
- 1966 Front valance side bracket screw kit, 4 hex washer-head screws, 1 set does both sides . . . . . 2HK88D 2.95 kit

## Sun Visor Hardware

- 61-63 Sun visor bracket screw set, 8 oval-head Phillips screws, 1 set does both sides . 2HK86A 5.95 set
- 64-66 Sun visor center bracket screw set, 2 oval-head Phillips screws. . . . . 2HK86B 2.95 set



## Trunk Hardware

61-63	Trunk hinge to lid hardware set, 4 faceted-flange-head black oxide finish bolts, 1 set does both sides. . . . .	2HK83A	5.95 set
61-63	Trunk hinge to fender brace hardware set, 6 faceted-flange-head black oxide finish bolts, 1 set does both sides. . . . .	2HK83C	7.95 set
61-63	Trunk latch hardware set, 3 hex-head bolts & 3 flat washers . . . . .	2HK83E	2.95 set
61-63	Trunk latch catch hardware set, 2 hex-head bolts & 2 flat washers . . . . .	2HK83G	2.95 set
61-63	Trunk lock retainer hardware set, 2 stamped nuts (1 notch) . . . . .	2HK83J	2.95 set
64-66	Trunk hinge to lid hardware set, 4 hex-head bolts (black oxide finish) with captive washers & 4 external-tooth lock-washers, 1 set does both sides . . . . .	2HK83B	5.95 set
64-66	Trunk hinge to body hardware set, 6 faceted-flange-head black oxide finish bolts & 6 external-tooth lock-washers, 1 set does both sides . . . . .	2HK83D	12.95 set
64-66	Trunk latch hardware set, 2 hex-head bolts with captive flat washers & 2 external-tooth lock-washers . . . . .	2HK83F	2.95 set
64-66	Trunk latch catch hardware set, 2 black oxide finish hex-head bolts with captive flat washers & 2 external-tooth lock-washers . . . . .	2HK83H	3.95 set
64-66	Trunk lock assembly hardware set, 2 pan-head Phillips screws & 2 black oxide finish nuts with captive washers. . . . .	2HK83K	4.95 set

## Interior Panel, Headliner & Upholstery Hardware

The following sets contain enough to do both sides.

61-63	Kick panel screw set, 8 round washer-head Phillips screws. . . . .	2HK91A	4.95 set
61-63	Inner rear quarter cover screw set, 4 oval-head Phillips screws. . . . .	2HK91C	3.95 set
61-63	Door trim panel rear retainer screw set, 4 oval-head Phillips screws. . . . .	2HK91J	2.95 set
61-63	Door panel armrest cup screw set, 4 oval-head Phillips screws. . . . .	2HK91N	3.95 set
61-63	Door trim panel front retainer screw set, 8 oval-head Phillips screws. . . . .	2HK91H	3.95 set
61-63	Door light bezel screw set, 4 oval-head Phillips screws. . . . .	2HK91P	2.95 set
1964	Front seatback panel installation set, 12 oval-head Phillips screws, 1 set does 2 seatbacks. . . . .	2HK91R	4.95 set
1965	Rear seat panel screw set, 4 oval-head Phillips screws. . . . .	2HK91S	2.95 set
64-66	Kick panel screw set, 6 flat-top round washer-head screws . . . . .	2HK91B	4.95 set
64-66	Inner rear quarter moulding screw set, 4 flat-head Phillips screws . . . . .	2HK91D	2.95 set
64-66	Inside rear window top moulding hardware set, 3 oval-head Phillips screws . . . . .	2HK91E	2.95 set
64-66	Inside rear window side moulding screw set, 6 oval-head Phillips screws. . . . .	2HK91F	2.95 set
64-66	Package tray hardware kit, 8 pan-head & 2 oval-head Phillips screws. . . . .	2HK91G	3.95 kit
64-66	Inside moulding over door screw set, 6 oval-head Phillips screws. . . . .	2HK91K	2.95 set
64-66	Top protective moulding at rear of door screw set, 4 oval-head Phillips screws, black oxide finish. . . . .	2HK91L	2.95 set
64-66	Stainless steel door panel moulding screw set, 8 oval-head Phillips screws . . . . .	2HK91M	4.95 set
64-66	Rear seat armrest screw set, 4 pan-head slotted screws . . . . .	2HK91T	2.95 set

64-66	Rear seat armrest top cap screw set, 4 flat-top round washer-head Phillips screws. . . . .	2HK91U	3.95 set
-------	--------------------------------------------------------------------------------------------	--------	----------



58-66	Upholstery hog rings, 100-piece set . . . . .	T4406U	2.95 set
-------	-----------------------------------------------	--------	----------



58-66	Hog ring pliers, installation tool for upholstery hog rings . . . . .	T4407U	24.95
-------	-----------------------------------------------------------------------	--------	-------

## Trim & Moulding Hardware

Our assortment of moulding fasteners has grown over the years, but it never seems to be enough! We carry as many different types as we can get our hands on but we don't have them all. The applications are given as accurately as possible. Ford used alternate metal & plastic clips on their mouldings

1960	Pal nut, for COSB-8259-A upper grille panel emblem (3 required) . . . . .	373503-S	0.50
1960	Pal nut, for COSB-6350286-A roof side emblem (6 required) . . . . .	373503-S	0.50
1962	Pal nut, for C2SZ-63290A76-B quarter panel ornament (12 required) . . . . .	373503-S	0.50
1963	Pal nut, for C3SZ-6325622-A quarter panel nameplate (6 required) . . . . .	373503-S	0.50
1963	Pal nut, for C3SZ-6320980-A door ornament (24 required) . . . . .	373503-S	0.50
61-63	Fender peak moulding clip, metal (as required) . . . . .	C1SZ-6329144-A	2.95
61-63	Fender peak moulding clip, plastic (as required). . . . .	C2SZ-6329144-A	1.95
61-63	Fender peak moulding end clip, 4 required per car (4 required) . . . . .	C1SZ-16A076-A	2.95
61-63	Hood grille to bezel hardware set, 3 stamped nuts (1 notch) . . . . .	2HK54F	2.95 set
63-64	Pal nut, for C1SZ-63517A08-A roof side emblem (6 required) . . . . .	373503-S	0.50
1966	Hood center ornament hardware set, 5 stamped nuts (1 notch) . . . . .	2HK54G	2.95 set
1966	Grille moulding under headlight ("eyebrow") hardware kit, 2 pan-head Phillips screws & 6 barrel clips, 1 kit does both sides . . . . .	2HK28J	6.95 kit
1966	Grille moulding center clip hardware set, 2 flat-top round washer-head Phillips screws & 2 spring-type "U" nuts . . . . .	2HK28K	2.95 set
1966	Complete grille moulding hardware kit, 8 flat-top round washer-head Phillips screws, 8 spring-type "U" nuts, 2 pan-head Phillips screws, 3 hex nuts with captive lock-washers & 6 blind nuts . . . . .	2HK28L	17.95 kit
1966	Grille center ornament hardware set, 3 hex nuts with captive external-tooth lock-washers . . . . .	2HK28M	2.95 set
1966	Moulding clip, for windshield . . . . .	D1AZ-6542413-B	0.95

All Pal Nuts are self-threading, for 3/16" studs.



D1AZ-6542413-B



C1SZ-6329144-A



C2SZ-6329144-A



C1SZ-16A076-A



# What's Your Favorite CLUB?



## Why Not Make Yours a Thunderbird Owners Club

Even though there are tens of thousands of 1955–66 Bird owners, they all have one thing in common: Love of their automobiles. The classic styling, with its underlying power and heritage, is what makes these cars unique, and the reason onlookers can't help but stare.

No matter how much an owner knows about his vehicle, he can always benefit from the knowledge of other owners. Thunderbird clubs allow the exchange of information between men and women who have a passion for their hobby, and provide an owner the opportunity to see what other owners have done with their cars.

Members of T-Bird clubs are part of a fraternity that is among the best in the world and enjoy helping others who share the same desire to own a piece of motoring history and preserve it well into the 21st Century. It's also a time-saving advantage to get advice from others who have "been there, done that" when it comes to repairs and restoration. Plus, there are many other reasons to become a member.

So why not check out a Thunderbird club in your area or, if you can't find one, look into forming one.



The **International Thunderbird Club** is coming to Lockport, NY (MAC's hometown), August 23–30, 2009, for its 16th annual convention. The ITC has chapters and members throughout the world. If you're interested in joining or forming your own chapter, visit the Web site [www.intl-tbirdclub.com](http://www.intl-tbirdclub.com).



### Check out:

**Vintage Thunderbird Club International**  
1304 Greenwood • Shertz, TX • 78154  
(210) 566-2118 • [www.vintageThunderbirdclub.org](http://www.vintageThunderbirdclub.org)

**Classic Thunderbird Club International**  
1308 E. 29th St. • Signal Hill, CA • 90806  
(562) 426-2709 (9 a.m. – 3 p.m. PST) • [www.ctci.org](http://www.ctci.org)





<b>A</b>		Lens to Housing Gasket . . . . .	208	Backing Plate Gasket . . . . .	157
"A" Pillar Seal . . . . .	221	Switch . . . . .	183	Banjo Bolt . . . . .	160
<b>Accelerator Parts . . . . .</b>	<b>193</b>	<b>Bag, Windshield Washer . . . . .</b>	<b>214</b>	Booster, Power . . . . .	162
Pedal . . . . .	193	Bracket . . . . .	214	Drum . . . . .	158
Linkage Seal . . . . .	193	<b>Ball Joint . . . . .</b>	<b>168</b>	<b>Brake Hose . . . . .</b>	<b>160</b>
Rod Parts . . . . .	193	<b>Bar Kit, Grille . . . . .</b>	<b>231</b>	Clip . . . . .	160
Pump Diaphragm . . . . .	191	<b>Baseball Cap . . . . .</b>	<b>129</b>	<b>Brake Line Kit . . . . .</b>	<b>162</b>
<b>Accessories . . . . .</b>	<b>95-129</b>	<b>Batteries . . . . .</b>	195	Fitting . . . . .	161
<b>Adhesives . . . . .</b>	<b>116</b>	Box Apron Patch Panel . . . . .	235	<b>Brake Master Cylinder . . . . .</b>	<b>161</b>
<b>Air Baffle, Radiator . . . . .</b>	<b>186</b>	Cable . . . . .	197	Boot . . . . .	161
<b>Air Cleaner Wing Nut . . . . .</b>	<b>192</b>	Charger . . . . .	115	Filler Cap & Gasket . . . . .	161
Decals . . . . .	98	Decals & Tags . . . . .	99	Link Rod Bolt . . . . .	161
<b>Air Cleaner to Carburetor Top Gasket . . . . .</b>	<b>192</b>	Disconnect . . . . .	112	Outlet Fitting Bolt . . . . .	161
<b>Air Conditioner:</b>		Hardware . . . . .	240	Pushrod Bushing & "O" Ring . . . . .	161
Belt . . . . .	188	Hold-Down Bolt & Clamp . . . . .	196	Rebuild Kit . . . . .	161
Blower Motor Cover Seal . . . . .	220	Tray . . . . .	196	<b>Brake Pads &amp; Retainers, Disc . . . . .</b>	<b>162</b>
Blower Motor Vent Hose . . . . .	220	<b>Bearing:</b>		<b>Brake Pedal . . . . .</b>	<b>158</b>
Compressor . . . . .	219	Alternator . . . . .	195	Arm Bumper . . . . .	158
Clutch . . . . .	219	Axle Pinion . . . . .	169	Mounting Bracket Bushing . . . . .	158
Crankshaft Seal Kit . . . . .	219	Cam . . . . .	173-175	Pad . . . . .	158
Support Braces & Spacers . . . . .	220	Clutch Throwout . . . . .	183	<b>Brake Proportioning Valve Rebuild Kit . . . . .</b>	<b>161</b>
Control Cable . . . . .	219	Differential . . . . .	169	<b>Brake Rotor, Disc . . . . .</b>	<b>162</b>
Decals . . . . .	98	Main . . . . .	173-175	<b>Brake Shoe . . . . .</b>	<b>158</b>
Door Vacuum Motor . . . . .	219	Rod . . . . .	173-175	Adjusting Springs . . . . .	159
Hardware . . . . .	241	Steering Column . . . . .	165	"C" Clip . . . . .	159
Hose Tag . . . . .	99	Steering Gearbox Sector Shaft . . . . .	165	Hold Down Kit . . . . .	159
Receiver/Drier Decal . . . . .	99	Steering Gearbox Worm Roller . . . . .	165	Return Springs . . . . .	158
Vacuum Canister . . . . .	220	Wheel . . . . .	157	Self-Adjuster Assembly . . . . .	159
<b>Air Filter . . . . .</b>	<b>182</b>	<b>Bell Housing Inspection Plate &amp; Gasket</b>		<b>Breather/Filler Cap, Oil . . . . .</b>	<b>180</b>
<b>Alternator . . . . .</b>	<b>194-195</b>	Automatic Transmission . . . . .	<b>185</b>	<b>Brookland Road Test Books . . . . .</b>	<b>109</b>
Belt . . . . .	188	<b>Bellows, Cruise Control . . . . .</b>	<b>193</b>	<b>Bulb, Light . . . . .</b>	<b>204</b>
Fan . . . . .	194	<b>Belt, Fan . . . . .</b>	<b>188</b>	<b>Bulb Pigtail, Headlight . . . . .</b>	<b>200</b>
Front Bearing . . . . .	195	<b>Belt Weatherstrip Kits . . . . .</b>	<b>223</b>	<b>Bumper Parts . . . . .</b>	<b>217-218</b>
Idle Pulley Mounting Bracket . . . . .	195	<b>Bezel:</b>		Bolt . . . . .	217
PowerGen . . . . .	194	Back-Up Light . . . . .	203	Bullet Filler . . . . .	217
Repair Kit . . . . .	194	Dash . . . . .	207	Center Emblem . . . . .	218
Splash Shield . . . . .	195	Dome Light . . . . .	202	Hardware . . . . .	241
Voltage Regulator . . . . .	195	Hood Emblem . . . . .	231	Splash Panel . . . . .	217
Plug & Wires . . . . .	195	Roof Side Emblem . . . . .	234	<b>Bumper to Body Seal Kit . . . . .</b>	<b>217</b>
<b>Antenna Assembly . . . . .</b>	<b>156</b>	Tail Light Lens . . . . .	203	<b>Bumpers:</b>	
Lead-in Wire Grommet . . . . .	156	<b>Bleeder Screw, Wheel Cylinder . . . . .</b>	<b>160</b>	Axle . . . . .	169
<b>Antenna Toppers . . . . .</b>	<b>121</b>	<b>Blower Motor, Heater . . . . .</b>	<b>219</b>	Control Arm . . . . .	168
<b>Antifreeze Tags . . . . .</b>	<b>98</b>	<b>Body Side Moulding . . . . .</b>	<b>231</b>	Door . . . . .	227
<b>Armrest Cover . . . . .</b>	<b>144</b>	<b>Body, Trim &amp; Sealant</b>		Gas Tank Filler Door . . . . .	190
<b>Ashtray Hardware . . . . .</b>	<b>241</b>	Assembly Manuals . . . . .	<b>104</b>	Glovebox Door . . . . .	211
<b>Automatic Choke Tube . . . . .</b>	<b>192</b>	<b>Body Wiring Harness . . . . .</b>	<b>206</b>	Hood . . . . .	212
Insulator . . . . .	192	<b>Bolt:</b>		License Plate . . . . .	217
<b>Automatic Transmission Parts . . . . .</b>	<b>184-185</b>	Backing Plate . . . . .	159	Stickers . . . . .	102
Dipstick . . . . .	184	Banjo . . . . .	160	Trunk Lid . . . . .	151
Extension Housing:		Battery Hold-down . . . . .	196	<b>Button, Door Lock . . . . .</b>	<b>226</b>
Bushings . . . . .	184	Bumper . . . . .	217	Grommet . . . . .	226
Gasket . . . . .	184	Master Cylinder Link Rod . . . . .	161	<b>Bypass Hose, Water . . . . .</b>	<b>187</b>
Seal . . . . .	184	Master Cylinder Outlet Fitting . . . . .	161	<b>Bypass Tube, Water . . . . .</b>	<b>187</b>
Kickdown Rod Return Spring . . . . .	185	<b>Bolt &amp; Lock Tab Kit, Exhaust Manifold . . . . .</b>	<b>180</b>		
Lower Bell Housing Inspection Plate		<b>Books &amp; Manuals . . . . .</b>	<b>103-111</b>		
Gasket . . . . .	185	<b>Booster, Power Brake . . . . .</b>	<b>162</b>		
Manual Control Lever Oil Seal . . . . .	185	Rebuild Kit . . . . .	163		
Pan Gasket . . . . .	185	<b>Boot:</b>			
Screen & Pan Gasket Kit . . . . .	184	Clutch Fork . . . . .	183		
Shift Modulator Valve . . . . .	185	Master Cylinder . . . . .	161		
		<b>Bowl (Canister), Fuel Pump Filter . . . . .</b>	<b>182</b>		
		<b>Bracket:</b>			
		Fuel Filter . . . . .	182		
		License Plate . . . . .	217		
		Rear-view Mirror . . . . .	216		
		Stabilizer Bar Mounting . . . . .	168		
		Windshield Washer Bag . . . . .	214		
		<b>Brake Parts . . . . .</b>	<b>157-163</b>		
		Adjustment Hole Plug . . . . .	159		

<b>B</b>	
<b>Back of Vent Window Seal . . . . .</b>	<b>222</b>
<b>Back-up Lights &amp; Parts . . . . .</b>	<b>208</b>
Bezel . . . . .	208
Hardware . . . . .	208
Housing to Body Gasket . . . . .	208
Lens . . . . .	208

<b>C</b>	
<b>"C" Clip, Brake Shoe . . . . .</b>	<b>159</b>
<b>"C" Clip, Inside Door &amp; Window</b>	
Crank Handle . . . . .	228
"C" Clip Removal Tool . . . . .	228
<b>CD Player . . . . .</b>	<b>154</b>
<b>Cable:</b>	
Air Conditioner Control . . . . .	219
Battery . . . . .	197
Brake Self-Adjuster . . . . .	159
Emergency Brake & Clip . . . . .	163
Heater Control . . . . .	219
Speedometer . . . . .	208
Lubricant . . . . .	208
Starter Bracket & Grommet . . . . .	196



- Caliper, Disc Brake** ..... 162
- Transfer Tube ..... 162
- Camshaft** ..... 173-175
- Bearings ..... 173-175
- Gear ..... 176
- Canceling Cam, Turn Signal Switch** .... 209
- Canister, Fuel Pump Filter** ..... 182
- Cap:**
- Distributor ..... 199
- Gas ..... 190
- Hub Grease ..... 157
- Master Cylinder ..... 161
- Oil Filler/ Breather ..... 180
- Power Steering Pump Filler..... 166
- Radiator ..... 186
- Water Outlet ..... 187
- Car Cover** ..... 114-115
- Lock & Cable ..... 115
- Carburetor** ..... 191
- Accelerator Pump Diaphragm ..... 191
- Air Cleaner Parts ..... 192
- Books ..... 108
- Dash Pot ..... 191
- Linkage Kit ..... 192
- Spacer ..... 192
- Plate Gaskets ..... 192
- to Pump Fuel Line ..... 191
- Top Gasket to Air Cleaner ..... 192
- Tune-up Kit ..... 191
- Carpet & Floor Mats** ..... 147
- Center Link** ..... 164
- Center Pad, Leaf Spring** ..... 171
- Chain, Timing** ..... 176
- Choke Tube, Automatic** ..... 192
- Insulator ..... 192
- Cigar Lighter:**
- Element ..... 210
- Knobs & Parts ..... 210
- Socket ..... 210
- Clutches & Parts** ..... 183
- Air Conditioner Compressor ..... 219
- Fan ..... 188
- Fork Boot ..... 183
- Pedal Mounting Bracket Bushing ..... 158
- Pedal Pad ..... 158
- Pilot Bushing ..... 183
- Pressure Plate ..... 183
- Release Lever Shaft Bushing ..... 183
- Throwout Bearing & Hub ..... 183
- Coat Hook Kit** ..... 144
- Coil, Ignition** ..... 199
- Coil Resistor Ignition** ..... 199
- Coil Springs** ..... 171
- Insulator ..... 171
- Compressor, Air Conditioner** ..... 219
- Clutch ..... 219
- Condenser, Distributor** ..... 199
- Connecting Rod** ..... 175-175
- Connecting Sleeve, Tie Rod** ..... 164
- Console Hardware** ..... 241
- Console Trim** ..... 208
- Constant Voltage Regulator, Instrument Cluster** ..... 208
- Control Arm:**
- Bumper ..... 168
- Bushing ..... 168
- Shaft Kit ..... 168
- Control Cable, Air Conditioner** ..... 219
- Control Cable, Heater** ..... 219

- Control Valve:**
- Power Steering ..... 167
- Heater Hot Water ..... 218
- Convertible Parts** ..... 148-150
- Cowl Brace ..... 148
- Deck (Trunk) Lid Lift Cylinder ..... 149
- Front Header Seal ..... 150
- Roof Rail Seal Kit ..... 149
- Tack Strip ..... 150
- Tonneau Cover Parts ..... 150
- Top ..... 150
- Arm Pads ..... 150
- Arm Seal ..... 150
- Cleaner ..... 119
- Control Relay ..... 148
- Hardware ..... 243
- Hose Set ..... 149
- Kit ..... 150
- Latch Handle ..... 148
- Latch "J" hook ..... 148
- Lift Cylinder ..... 149
- Limit Switch ..... 148
- Motor & Pump Assembly ..... 149
- Outer Front Seal ..... 149
- Pad ..... 150
- Protectant ..... 119
- Rear Side Rail to Lift Cylinder Bushing ..... 149
- Relay ..... 148
- Repair & Adjustment Manuals ..... 105
- Switch Handle ..... 148
- Escutcheon Plate ..... 148
- Trunk Drain Trough ..... 149
- Trunk Weatherstrip Kit ..... 149

- Courtesy Light:**
- Actuator Wedge ..... 202
- Assembly, Door ..... 202
- Hardware ..... 201
- Lens ..... 201
- Switch ..... 210

- Cover Gasket:**
- Axle ..... 169
- Timing ..... 178
- Valve ..... 178
- Cowl Vent Parts** ..... 211
- Drain Tube ..... 211
- Bracket ..... 211
- Hardware ..... 242
- Cowl to Hood Seal** ..... 221
- Crankshaft Parts** ..... 176
- Gear ..... 176
- Rear Main Seal Set ..... 176
- Vibration Damper ..... 176

- Cruise Control Bellows** ..... 192
- Fluid ..... 192
- Crush Collar, Pinion Bearing** ..... 169

- Cylinder & Keys:**
- Door Lock ..... 227
- Ignition Switch ..... 209
- Trunk Lock ..... 151

## D

- Damper, Crankshaft Vibration** ..... 176
- Dash Parts** ..... 206-211
- Bezel ..... 207
- Emblem ..... 208
- Hardware ..... 240
- Knobs ..... 207
- Noddors ..... 121

- Pad ..... 206
- Wiring Harness ..... 205
- Dash Pot** ..... 191
- Dealer Sales Brochures** ..... 205
- Decals & Tags** ..... 96-102
- Kits ..... 96-97
- Deck (Trunk) Lid:**
- Bumper ..... 151
- Lift Cylinder ..... 149
- Seal ..... 151
- to Rear Body Panel Seal ..... 151
- Deck Panel** ..... 238
- Deflector, Vent Window** ..... 214
- Defroster Hose Set** ..... 219
- Dial, Shift Selector** ..... 184
- Diaphragm, Carburetor:**
- Accelerator Pump ..... 191
- Differential Parts** ..... 169
- Bearing & Race Set ..... 169
- Pinion Shaft ..... 169
- Ring & Pinion ..... 169
- Dimmer Switch, Headlight** ..... 209
- Dipstick:**
- Oil ..... 179
- Tube ..... 179
- Disc Brakes & Parts** ..... 162
- Caliper ..... 162
- Transfer Tube ..... 162
- Pad Retainer or Shield ..... 162
- Pads ..... 162
- Rotor ..... 162
- Disc, Clutch** ..... 183
- Distributor** ..... 198
- Cap ..... 199
- Condenser ..... 199
- Gear ..... 198
- Points ..... 199
- Rotor ..... 199
- Tune-up Kit ..... 199
- Vacuum Advance ..... 198
- Vacuum Lines ..... 198
- Dog Leg Seal, Door** ..... 222
- Dome Light Bezel** ..... 202
- Door Parts** ..... 226-230
- Bumper ..... 227
- Carpet ..... 147
- Courtesy Light Assembly ..... 202
- Emblem ..... 233
- Handle "C" clip ..... 228
- Removal Tool ..... 228
- Handle, Inside ..... 227
- Escutcheon Plate ..... 228
- Nylon Plate ..... 228
- Panel Aluminum Trim ..... 143
- Panel Pull Cap ..... 143
- Panel Retainer ..... 143
- Handle, Outside ..... 228
- Pads ..... 229
- Pushbutton ..... 228
- Hardware ..... 242-243
- Hinge Pin ..... 227
- Bushing ..... 227
- Inner Dogleg Seal ..... 222
- Latch ..... 226
- Striker Plate ..... 226
- Lock Button ..... 226
- Grommet ..... 226
- Lock Cylinder & Keys ..... 227
- Retaining Clip ..... 227



Lock Lever ..... 226  
 Lock & Ignition Key Cylinder Set ..... 227  
 Lock Knobs ..... 121  
 Nameplate ..... 226  
   Scuff Plates ..... 226  
   Emblems ..... 233  
 Trim Panels ..... 142-143  
 Wiring Shield ..... 206  
**Door Seals ..... 222**  
**Doorskin Patch Panel ..... 237**  
**Drag Link (Center Link) ..... 164**  
**Drain:**  
   Hose, Trunk ..... 151  
   Plug, Oil Pan ..... 179  
   Seal, Lower Door ..... 227  
   Tube, Cowl Vent ..... 210  
**Driven Gear, Speedometer ..... 208**  
   Retainer ..... 208  
**Drum, Brake ..... 158**  
**Duster, Car ..... 113**

## E

**Electrical Assembly Manuals ..... 104**  
**Electric Clock Wiring ..... 206**  
**Emblem:**  
   Bumper Center ..... 218  
   Hood ..... 231  
   Bezel ..... 231  
   Insert ..... 231  
   Landau ..... 223  
   Rear-view Mirror ..... 215  
   Roof Side ..... 234  
   Bezel ..... 234  
   Insert ..... 234  
   Scuff Plate ..... 226  
   Wheel Cover ..... 156  
**Emergency Brake Parts ..... 163**  
   Cable & Clips ..... 163  
   Equalizer Rod ..... 163  
   Pedal Pad ..... 163  
   Ratchet Parts ..... 163  
   Vacuum Canister ..... 163  
**End Cap, Peak Moulding ..... 232**  
**End Repair Kit, Stabilizer Bar ..... 168**  
**Engine Parts ..... 173-175**  
**Engine Compartment Decals ..... 98-100**  
**Engine Gaskets ..... 178**  
**Engine Gauge Feed ..... 205**  
**Engine Overhaul Gasket Sets ..... 178**  
**Engine Rebuild Supplies ..... 116-117**  
**Engine & Transmission Mounts ..... 170**  
**Engine & Transmission Rebuilding**  
   **Books ..... 108**  
**Escutcheon Plate:**  
   Convertible Top Switch Handle ..... 148  
   Inside Door Handle ..... 228  
   Power Window Switch ..... 230  
**Exhaust Hangers ..... 170**  
**Exhaust Manifold Gaskets ..... 180**  
   Bolt & Lock Tab Kit ..... 180  
**Exhaust Valve ..... 173-175**  
**Expansion Tank ..... 185**  
**Extension Housing Bushing:**  
   Automatic Transmission ..... 184  
   Manual Transmission ..... 183  
**Extension Housing Gasket, Automatic**  
   **Transmission ..... 184**  
**Extension Housing Seal:**  
   Automatic Transmission ..... 184

Manual Transmission ..... 183

## F

**Facts & Feature Manuals ..... 105**  
**Fan:**  
   Belts ..... 188  
   Decals ..... 99  
   Shroud ..... 186  
**Fan Blades & Fan Clutches ..... 188**  
**Fast Idle Cam Lever ..... 192**  
**Fasteners & Hardware ..... 240-244**  
**Fender Parts:**  
   Gripper ..... 115  
   Hardware ..... 242  
   Lower Patch Panels ..... 235  
   Nameplate ..... 232  
   Peak Moulding ..... 232  
   Skirt ..... 237  
   Pins ..... 237  
   Seals ..... 237  
   Top Ornament ..... 232  
   Top Turn Indicator ..... 232  
**Filler/ Breather Cap, Oil ..... 180**  
**Filler Cap, Master Cylinder ..... 161**  
   Gasket ..... 161  
**Filler Cap, Power Steering Pump ..... 166**  
**Filler, Gas Tank:**  
   Door Bumper ..... 190  
   Neck to Body Seal ..... 189  
**Filter Canister, Fuel Pump ..... 190**  
**Filters ..... 182**  
   Eaton Power Steering Pump ..... 166  
   Gas Tank Sending Unit ..... 190  
**Firewall Covers & Parts ..... 211**  
   Grommet ..... 211  
   Firewall to Headlight Junction Wire ..... 205  
**Flame Thrower Wire Set ..... 198**  
**Flashers, Turn Signal ..... 209**  
**Flip Lid Gear Box ..... 149**  
**Float, Gas Tank Sending Unit ..... 190**  
**Floor:**  
   Carpet Sets ..... 147  
   Mats ..... 146  
   Carpeted ..... 147  
   Pan ..... 236  
   Plug ..... 236  
   Patch Panels, Trunk ..... 236  
**Flex Plate ..... 176**  
**Ford Books, History ..... 110**  
**Ford Decals ..... 101**  
**Ford Road Series Books ..... 109**  
**Frame, License Plate ..... 113**  
**Fresh Air Inlet Seal ..... 219**  
**Fuel System ..... 189-193**  
   Filter ..... 182  
   Decals ..... 99  
   In-line ..... 182  
   Log Assembly ..... 191  
   Pump ..... 190  
   Filter Canister ..... 190  
   Mounting Gasket ..... 191  
   to Carburetor Fuel Line ..... 191  
   Stabilizer ..... 115  
   Vacuum Lines, Fuel Pump ..... 191  
**Fuses ..... 206**

## G

**Gas:**  
   Cap ..... 190

**Gas Pumps, (Novelty) ..... 125**  
**Gas Tank ..... 189**  
   Filler Door Bumper ..... 190  
   Filler Neck to Body Seal ..... 189  
   Gauge Sending Unit ..... 189  
   Hardware ..... 189  
   Neck Grommet ..... 189  
   Neck "O" ring ..... 189  
   Sending Unit:  
     Filter ..... 190  
     Float ..... 190  
     Lock Ring ..... 190  
     "O" ring ..... 190  
   Slushing Compound ..... 117  
**Gaskets, Engine ..... 178**  
   Automatic Transmission:  
     Extension Housing ..... 184  
     Pan ..... 185  
   Back-up Light Lens to Housing ..... 203  
   Carburetor Spacer Plate ..... 192  
   Carburetor Top to Air Cleaner ..... 192  
   Cylinder Head ..... 178  
   Engine Overhaul ..... 178  
   Fuel Pump Mounting ..... 191  
   Headlight Bucket ..... 200  
   Heater Core to Case ..... 218  
   Intake Manifold ..... 182  
   License Plate Lens ..... 217  
   Manual Transmission ..... 183  
   Oil Filter Mount ..... 180  
   Oil Pan ..... 178  
   Parking Light Lens ..... 201  
   Tail Light Lens to Housing ..... 203  
   Thermostat ..... 187  
   Timing Cover ..... 178  
   Valve Cover ..... 178  
   Water Pump to Block ..... 187  
**Gear:**  
   Camshaft ..... 176  
   Crankshaft ..... 176  
   Distributor ..... 198  
   Manual Vent Window Regulator ..... 223  
   Power Window Motor ..... 230  
   Speedometer ..... 208  
   Timing ..... 176  
**Gearbox, Steering:**  
   Insulator ..... 165  
   Rebuild ..... 165  
   Seal Kit ..... 165  
   Sector Shaft Bearing ..... 165  
   Sector Shaft Bushing ..... 165  
   Sector Shaft Seal ..... 165  
   Worm Roller Bearing ..... 165  
**Gearshift Lever Parts ..... 184**  
**Generators ..... 193**  
   Belt ..... 188  
   Decals & Tags ..... 98  
   Rebuild Kits ..... 194  
   Splash Shield ..... 194  
   Voltage Regulator ..... 194  
**Glass Bedding ..... 230**  
**Glass Fuses ..... 206**  
**Glovebox Parts ..... 210**  
   Decals ..... 100  
**Gravel Guard, Shock Absorber ..... 172**  
**Grease ..... 116**  
**Grease Cap, Hub ..... 157**  
**Grease Seals ..... 157**  
**Grille Bar Kit ..... 231**





Grille Hardware ..... 240  
 Grille Upper Panel Emblem, Radiator ... 231  
 Ground Strap ..... 196  
 Guide, Valve ..... 173-175

## H

**Handle:**  
 Convertible Top Latch ..... 148  
 Convertible Top Switch ..... 148  
 Door, Inside ..... 227  
 Plate, Nylon ..... 228  
 Door, Outside ..... 228  
 Pad ..... 229  
 Pushbutton ..... 228  
 Hood Release ..... 212  
 Quarter Window Crank ..... 228  
 Vent Window ..... 222  
 Window Crank ..... 228  
**Handle "C" clip ..... 228**  
 "C" clip Removal Tool ..... 228  
**Hangers, Exhaust ..... 170**  
**Hardware & Fasteners ..... 240-244**  
**Harmonic Balancer (Crankshaft Vibration Damper) ..... 176**  
**Hat Pins ..... 124-125**  
**Head Gasket Set ..... 178**  
**Header Seal, Convertible ..... 150**  
**Headlights & Parts ..... 200**  
 Adjuster Kit ..... 200  
 Adjusting Nut ..... 200  
 Spring ..... 200  
 Bucket Gasket ..... 200  
 Bulb Pigtail ..... 200  
 Dimmer Switch ..... 209  
 Cover ..... 209  
 Door ..... 200  
 Seal ..... 200  
 Hardware ..... 200  
 Headlight to Firewall Junction Wire ..... 205  
 Knob & Shaft ..... 209  
 Socket & Wire ..... 205  
 Switch ..... 209  
**Headliners ..... 144**  
 Installation Tool ..... 112, 119  
**Heater & Air Conditioning Parts ..... 218-220**  
 Blower Motor ..... 219  
 Control Cable ..... 219  
 Core ..... 218  
 Core to Case Gasket ..... 218  
 Hose ..... 218  
 Hot Water Control Valve ..... 218  
**Heat Riser Spacers ..... 180**  
**Heat Riser Valves ..... 180**  
**Hinge, Hood ..... 212**  
**Hinge Cover Set, Seat ..... 140**  
**Hinge Pin, Door ..... 227**  
 Bushing ..... 227  
**Hold-Down:**  
 Battery ..... 196  
 Spare Wheel ..... 151  
**Hood Parts ..... 212**  
 Accessory Light ..... 112  
 Bumper ..... 212  
 Cowl Seal ..... 221  
 Emblem ..... 231  
 Bezel ..... 231  
 Insert ..... 231  
 Hardware ..... 242

Hinge ..... 212  
 Insulation Pad Set ..... 212  
 Letters ..... 231  
 Lock Cam Bumper ..... 212  
 Moulding ..... 231  
 Radiator Support Seal ..... 221  
 Release Handle ..... 212  
**Horn & Parts ..... 205**  
 Button Insulator ..... 205  
 Hardware ..... 205  
 Relay ..... 205  
 Ring ..... 205  
 Ring Ornament ..... 205  
**Hose:**  
 Air Conditioner Blower Motor Vent ..... 220  
 Bypass ..... 187  
 Heater ..... 218  
**Hose Clamp, Radiator ..... 187**  
**Hose Tag, Air Conditioner ..... 98**  
**Hose Tee, Windshield Washer ..... 213**  
**Hot Water Control Valve ..... 218**  
**Hub Grease Cap ..... 157**

## I

**Identification Books ..... 106**  
**Idle Cam Lever ..... 192**  
**Idler Arm ..... 164**  
 Bushing & Seal ..... 164  
**Ignitor ..... 198**  
**Ignition Coil ..... 199**  
 Decals ..... 98  
 Flame Thrower ..... 198  
 Resistor ..... 199  
**Ignition Decals, Transistorized ..... 99**  
**Ignition Key & Door Lock Cylinder Set ..... 227**  
**Ignition Switch ..... 208**  
**Ignition Switch Cylinder & Keys ..... 208**  
**Inlet Seal, Fresh Air ..... 219**  
**Inside Handles: Doors & Windows ..... 227**  
**Instrument Cluster Constant Voltage Regulator ..... 208**  
**Insulation ..... 119**  
**Insulation Pad Set, Hood ..... 212**  
**Insulator:**  
 Automatic Choke Tube ..... 192  
 Coil Spring ..... 171  
 Gearshift Lever ..... 184  
 Horn Button ..... 205  
 Steering Gearbox ..... 165  
**Intake Manifold Gasket Set ..... 180**  
**Intake Valve ..... 173-175**  
**Interior/Body Assembly Manuals ..... 104**  
**Interior:**  
 Decals ..... 100-101  
 Door Trim Panels ..... 142-143  
 Kick Panels ..... 140  
 Lights ..... 201-202  
 Panel Hardware ..... 244  
 Pillar Light Assembly ..... 201  
 Quarter Trim Panels ..... 144  
 Screw Kit ..... 240  
 Seat Belts ..... 141  
 Trunk ..... 153  
 Fasteners ..... XXX

## J

"J" hook, Convertible Top Latch ..... 148  
 Jack Instructions Decals ..... 100

## K

**Keeper, Valve ..... 173-175**  
**Key Blanks ..... 112 & 227**  
**Key Fob ..... 112**  
**Key & Cylinder:**  
 Door Lock ..... 227  
 Ignition Switch ..... 208  
 Trunk Lock ..... 151  
**Keyhole Cover, Trunk Lock**  
 Ornament ..... 152  
 Spring ..... 152  
**Kick Panel ..... 140**  
**Kickdown Rod Return Spring, Automatic Transmission ..... 185**  
**Knobs:**  
 Dash ..... 207  
 Headlight ..... 209  
 Seat Adjustment ..... 139  
 Turn Signal Lever ..... 210

## L

**Landau Bars ..... 233**  
**Landau Emblem ..... 233**  
**Landau Top (Vinyl Top) ..... 225**  
**Latch, Door ..... 226**  
 Striker Plate ..... 226  
**Latch Handle, Convertible Top ..... 148**  
 "J" hook, Convertible Top ..... 148  
**Lead-In Wire Grommet, Radio Antenna ..... 156**  
**Leaf Springs ..... 171**  
 Bushings ..... 172  
 Center Pad ..... 171  
 Shackles Kit ..... 172  
**Lens:**  
 Back-up Light ..... 203  
 Courtesy Light ..... 201  
 Dome Light ..... 201  
 License Plate Light ..... 217  
 Map Light ..... 201  
 Parking Light ..... 201  
 Tail Light ..... 202  
**Lever:**  
 Door Lock ..... 226  
 Fast Idle Cam ..... 192  
 Gearshift ..... 183  
**License Plates ..... 113**  
 Frames ..... 113  
 Reflective Bolts ..... 113  
**License Plate Light & Parts ..... 217**  
 Bracket ..... 217  
 Hardware ..... 217  
 Bumper ..... 217  
 Lens ..... 217  
 Gasket ..... 217  
**Lift Cylinder, Convertible Trunk Lid ..... 149**  
**Lift Cylinder, Convertible Top ..... 149**  
**Lifter, Valve ..... 173-175**  
**Light Bulbs ..... 204**  
**Light Switch:**  
 Back-up ..... 183  
 Courtesy ..... 210  
 Stop ..... 210  
**Lighter Assembly, Cigar ..... 210**  
 Element ..... 210  
 Socket ..... 210  
**Limit Switch, Convertible Top ..... 148**  
**Liner, Glovebox ..... 211**  
**Linkage Kit, Carburetor ..... 193**  
**Linkage Seal, Accelerator Pedal ..... 193**



**Lock:**

- Base Gasket, Trunk . . . . . 152
- Button . . . . . 226
- Grommet . . . . . 226
- Cylinder & Keys:
  - Door . . . . . 227
  - Trunk . . . . . 151
- Cylinder Retaining Clip . . . . . 227
- Extension, Trunk . . . . . 152
- Lever . . . . . 226
- Ornament, Trunk . . . . . 152
  - Insert . . . . . 152
- Ornament Keyhole Cover, Trunk . . . . . 152
- Spring . . . . . 152
- Ring, Gas Tank Sending Unit . . . . . 190
- Tab & Bolt Kit, Exhaust Manifold . . . . . 180

**Lug Nut . . . . . 156**

## M

- Main Bearings . . . . . 173-175**
- Manifold Gasket Sets . . . . . 180**
  - Bolt & Lock Tab Kit, Exhaust . . . . . 180
- Manual & Power Window Parts . . . . . 229-230**
- Manual Control Lever Oil Seal, Automatic Transmission . . . . . 185**
- Manual Transmission Parts . . . . . 183**
  - Extension Housing Bushing . . . . . 183
  - Extension Housing Seal . . . . . 183
  - Gasket Set . . . . . 183
  - Overdrive Housing Bushing . . . . . 183
  - Overdrive Housing Seal . . . . . 183
- Map Light & Lens . . . . . 201**
- Master Cylinder . . . . . 161**
  - Boot . . . . . 161
  - Filler Cap & Gasket . . . . . 161
  - Link Rod Bolt . . . . . 161
  - Outlet Fitting Bolt . . . . . 161
  - Pushrod Bushing . . . . . 161
  - Rebuild Kit . . . . . 161
- Mat, Floor . . . . . 146-147**
- Mirrors . . . . . 215-216**
  - Hardware . . . . . 242
- Modulator Valve, Automatic Transmission Shift . . . . . 185**
- Moly Piston Ring Set . . . . . 173-175**
- Motor:**
  - & Pump Assembly, Convertible Top . . . . . 149
  - Air Conditioner Door . . . . . 219
  - Heater Blower . . . . . 219
  - Mount . . . . . 170
  - Starter . . . . . 196
- Moulding:**
  - Hood . . . . . 231
  - Fender Peak . . . . . 232
  - Body Side . . . . . 234
  - Quarter Panel Peak . . . . . 233
    - End Caps . . . . . 232
- Moulding & Trim Hardware . . . . . 244**
- Moulding Clips . . . . . 232**
- Mount:**
  - Engine . . . . . 170
  - Oil Filter . . . . . 180
  - Transmission . . . . . 170
- Mounting Bracket Bushing:**
  - Brake Pedal . . . . . 158
  - Clutch Pedal . . . . . 158
- Mounting Gasket, Fuel Pump . . . . . 191**
- Muffler, Smithy . . . . . 170**

## N

- Nameplates**
  - Door . . . . . 233
  - Fender . . . . . 232
  - Quarter Panel . . . . . 233
- Neck, Gas Tank Filler:**
  - Body Seal . . . . . 189
  - Grommet . . . . . 189
  - "O" ring . . . . . 189
- Neutral Safety Switch . . . . . 184**
- Nostalgia Decals . . . . . 101-102**
- Novelties . . . . . 122-123**
- Nut:**
  - Headlight Adjusting . . . . . 200
  - Lug . . . . . 156
  - Windshield Wiper Pivot Shaft . . . . . 214
- Nylon Plate, Window Crank . . . . . 228**

## O

- "O" ring:**
  - Gas Tank Neck . . . . . 189
  - Gas Tank Sending Unit . . . . . 190
  - Pinion Bearing Retainer . . . . . 169
- Oil . . . . . 116**
- Oil Dipstick & Tube . . . . . 180**
- Oil Filler/ Breather Cap . . . . . 179**
- Oil Filter . . . . . 182**
  - Decals . . . . . 99
  - Mount . . . . . 180
  - Gasket . . . . . 180
- Oil Pan & Drain Plug . . . . . 179**
- Oil Pan Gasket . . . . . 178**
- Oil Pressure Sending Unit . . . . . 179**
- Oil Pump & Parts . . . . . 179**
  - Rebuild Kit . . . . . 179
- Oil Seal, Axle Pinion . . . . . 169**
- Oil Slinger, Axle Pinion Shaft . . . . . 169**
- Ornament:**
  - Fender Top . . . . . 232
  - Horn Ring . . . . . 205
  - Quarter Panel . . . . . 233
  - Tonneau Cover . . . . . 150
  - Trunk Lock . . . . . 152
    - Insert . . . . . 152
    - Keyhole Cover . . . . . 152
    - Spring . . . . . 152
- Outlet Cap, Water . . . . . 187**
- Outside Door Handles & Pads . . . . . 229**
- Overdrive:**
  - Cable Assembly . . . . . 183
  - Housing Bushing . . . . . 183
  - Housing Seal . . . . . 183
  - Relay Wiring . . . . . 205
- Overhaul Gasket Set, Engine . . . . . 178**
- Owners Manuals . . . . . 105**

## P

- Package Tray Seal . . . . . 149**
- Pad:**
  - Convertible Top . . . . . 150
  - Convertible Top Arm . . . . . 150
  - Dash . . . . . 206
  - Disc Brake . . . . . 162
  - Door Handle . . . . . 229
  - Emergency Brake Pedal . . . . . 163
  - Hood Insulation . . . . . 212
  - Pedal . . . . . 158
- Paint Books . . . . . 107**

- Pan, Floor . . . . . 236**
- Pan Gasket, Automatic Transmission . . . . . 185**
- Pan Gasket, Oil . . . . . 178**
- Parking Lights . . . . . 200-201**
  - Body . . . . . 200
  - Body to Fender Pad . . . . . 201
  - Hardware . . . . . 201
  - Lens . . . . . 201
  - Gasket . . . . . 201
  - Socket . . . . . 201
- Patch, Cloth . . . . . 129**
- Patch Panels . . . . . 235-238**
  - Battery Box Apron . . . . . 235
  - Doorskin . . . . . 237
  - Fender . . . . . 235
  - Trunk Floor . . . . . 236
  - Wheelhouse . . . . . 237
- PCV Valve . . . . . 179**
  - Grommet . . . . . 179
- Peak Moulding, Fender . . . . . 232**
- Peak Moulding, Quarter Panel . . . . . 232**
  - End Cap . . . . . 232
- Pedal Cars . . . . . 126-127**
- Pedal Mounting Bracket Bushing . . . . . 158**
- Pedal Pads . . . . . 158**
- Pedal Rod Parts, Accelerator . . . . . 193**
- Performance Books . . . . . 108**
- Pertronix:**
  - Ignitor . . . . . 198
  - Flame Thrower Coil . . . . . 198
  - Wire Sets . . . . . 198
- Pillar Light Assembly, Interior . . . . . 201**
- Pinion Bearing:**
  - Axle . . . . . 169
  - Crush Collar . . . . . 169
  - Retainer, Axle . . . . . 169
  - Retainer "O" ring . . . . . 169
  - Spacer . . . . . 169
- Pinion Shaft, Differential . . . . . 169**
  - Oil Slinger . . . . . 169
- Piston Ring Set . . . . . 173-175**
- Pitman Arm . . . . . 168**
- Plug:**
  - Floor Pan . . . . . 236
  - Oil Pan Drain . . . . . 179
  - Spark . . . . . 199
- Plug Wire Set, Spark . . . . . 199**
  - Separator . . . . . 199
- Points, Distributor . . . . . 199**
- POR-15 Products . . . . . 120-121**
- Power Brake Boosters . . . . . 166**
  - Check Valve . . . . . 162
  - Rebuild Kit . . . . . 163
  - Vacuum Lines . . . . . 163
- Power Cylinder . . . . . 167**
  - Seal Kit . . . . . 167
- Power Seat Parts . . . . . 139**
  - Wiring . . . . . 205
- Power Steering System Parts . . . . . 166-167**
  - Belt . . . . . 188
  - Control Valve . . . . . 167
  - Line . . . . . 167
- Pump . . . . . 166**
  - Filler Cap . . . . . 166
  - Filter . . . . . 166
  - Seal Kit . . . . . 167
- Power Window:**
  - Lockout Switch . . . . . 230
  - Motor Gear . . . . . 230



Regulator Safety Relay	230
Regulator to Drive Assembly Coupling	230
Roller Assembly	230
Switch Housing, Plate & Gasket	229
Switch Escutcheon Plate	229
Housing	229
Switch Wiring	205
<b>PowerGen</b>	<b>194</b>
<b>Pressure Plate, Clutch</b>	<b>183</b>
<b>Price Lists</b>	<b>101</b>
<b>Pump:</b>	
Fuel	190
Filter Bowl (Canister)	190
Mounting Gasket	191
Oil	179
Rebuild Kit	179
Power Steering	166
Windshield Washer	214
<b>Pushbutton, Door Handle</b>	<b>228</b>
<b>Pushrod</b>	<b>173-175</b>

## Q

<b>Quarter (Patch) Panel</b>	<b>238</b>
Extension	236
Nameplate	233
Ornament	233
Peak Moulding & End Cap	232
<b>Quarter Post Seal</b>	<b>224</b>
<b>Quarter Trim Panels, Interior</b>	<b>144</b>
<b>Quarter Window Crank Handle</b>	<b>228</b>
<b>Quarter Window Front Seal</b>	<b>224</b>

## R

<b>Radiator Parts</b>	<b>186-187</b>
Air Baffle	186
Cap	186
Fan Shroud	186
Grille Upper Panel Ornament	231
Hardware	240
Hose, Plain & Script	186
Clamp	187
Petcock	186
<b>Radios &amp; Parts</b>	<b>154-156</b>
Hardware	240
<b>Rear Axle &amp; Differential Parts</b>	<b>169</b>
<b>Rear Bumper Stone Deflector Seals</b>	<b>225</b>
<b>Rear Main Seal Set</b>	<b>178</b>
<b>Rear-View Mirror:</b>	
Arm	216
Assembly	215-216
Base Gasket	216
Base Pad	216
Bracket	216
<b>Rebuild Kit:</b>	
Brake Master Cylinder	161
Brake Proportioning Valve	161
Carburetor Tune-up Kit	191
Oil Pump	179
Power Brake Booster	163
<b>Rebuilding Books, Engine &amp; Transmission</b>	<b>108</b>
<b>Regulator:</b>	
Alternator Voltage	195
Plug & Wires	195
Generator Voltage	194
Instrument Cluster Constant Voltage	208
<b>Relay:</b>	
Convertible Top Control	148
Horn	205

Starter	197
<b>Relay Wiring, Overdrive</b>	<b>205</b>
<b>Release Handle, Hood</b>	<b>212</b>
<b>Restoration Books</b>	<b>107-108</b>
<b>Restoration Supplies</b>	<b>118-119</b>
<b>Ring &amp; Pinion, Differential</b>	<b>169</b>
<b>Ring Set, Piston</b>	<b>173-175</b>
<b>Road Draft Tube</b>	<b>179</b>
<b>Rocker Arm &amp; Shaft</b>	<b>173-175</b>
<b>Rocker Panel</b>	<b>235</b>
<b>Rod Bearings</b>	<b>173-175</b>
<b>Roller Assembly, Window</b>	<b>230</b>
<b>Roof Parts:</b>	
Hardware	243
Side Emblem	234
Bezel	234
Insert	234
Side Rail Seal Sets	223
<b>Rotor, Disc Brake</b>	<b>162</b>
<b>Rotor, Distributor</b>	<b>199</b>

## S

<b>Schematic Decals</b>	<b>100</b>
<b>Scoot-a-longs</b>	<b>125</b>
<b>Scuff Plate</b>	<b>226</b>
Emblem	226
<b>Seals:</b>	
"A" pillar	221
Accelerator Pedal Linkage	193
Accelerator Pedal Rod	193
Air Conditioner Blower Motor Cover	220
Automatic Transmission Extension	
Housing	184
Manual Control Lever Oil	185
Axle Grease	169
Axle Pinion Oil	169
Back of Vent Window	227
Back Window	222
Body to Bumper	224
Convertible Header	150
Convertible Roof Rail	149
Convertible Top Arm	150
Convertible Top Outer Front	149
Crankshaft Rear Main	176
Door	222
Door Inner Dog Leg	222
Fender Skirt	237
Fresh Air Inlet	219
Gas Tank Filler Neck to Body	189
Headlight Door	200
Hood to Cowl	221
Hood to Radiator Support	221
Idler Arm	164
Lower Door Drain	227
Manual Transmission Extension Housing	183
Overdrive Housing	183
Power Cylinder	167
Power Steering Pump	166
Reservoir Top Seal	166
Quarter Post	224
Quarter Window	224
Radiator Support to Hood	221
Rear Main	178
Roof Side Rail	223
Steering Column	165
Steering Gearbox	165
Sector Shaft	165
Trunk Lid	151
to Rear Body Panel	151

Valve	173-175
Vent Bar Channel	222
Vent Window	222
Wheel Grease	517
Windshield	221
<b>Sealed Beam</b>	<b>200</b>
<b>Seat Belts</b>	<b>141</b>
<b>Seat Covers</b>	<b>132-138</b>
<b>Seat Parts</b>	<b>139</b>
Adjustment Knob & Clip	139
Foam	139
Hardware	140
Hinge Cover Set	140
Regulator Motor Drive Coupler	139
Side Skirts	140
Wiring	205
<b>Secret Audio</b>	<b>155</b>
<b>Sector Shaft, Steering Gearbox:</b>	
Bearing	165
Bushing & Seal	165
<b>Self Adjuster Assembly:</b>	
Brake Shoe	159
Cable	159
Repair Kit	159
<b>Sending Unit:</b>	
Gas Tank Gauge	189
Oil Pressure	179
Water Temperature	185
<b>Sequencer Kit, Turn Signal</b>	<b>210</b>
<b>Service Specification Decals</b>	<b>99</b>
<b>Shackle Kit, Leaf Spring</b>	<b>172</b>
<b>Sheet Metal &amp; Patch Panels</b>	<b>235-238</b>
Hardware	243
<b>Sheet Metal &amp; Welding Books</b>	<b>107</b>
<b>Shift Collar</b>	<b>184</b>
<b>Shift Knobs</b>	<b>120</b>
<b>Shift Modulator Valve, Automatic</b>	
Transmission	185
<b>Shift Selector Dial</b>	<b>184</b>
<b>Shirt, Tee</b>	<b>128-129</b>
<b>Shock Absorbers &amp; Bushings</b>	<b>172</b>
<b>Shoe, Brake</b>	<b>158</b>
Adjusting Springs, Brake	159
"C" Clip, Brake	159
Hold Down Kit, Brake	159
Return Springs, Brake	158
Self Adjuster Assembly, Brake	159
to Cylinder Link, Brake	159
<b>Shop Manuals</b>	<b>104</b>
<b>Sleeve:</b>	
Cylinder	173-175
Steering Column Bearing	165
Tie Rod Connecting	164
<b>Smithy Muffler</b>	<b>170</b>
Decal	170
<b>Socket:</b>	
Cigar Lighter	210
Headlight	205
Parking Light & Wire	201
Tail Light	202
<b>Solenoid (Starter Relay)</b>	<b>197</b>
<b>Sound Deadener</b>	<b>119</b>
<b>Spare Wheel Hold-down Parts</b>	<b>151</b>
Cover	153
<b>Spark Plug</b>	<b>199</b>
Wire Set	199
Separator	199
<b>Speaker Assembly, Radio</b>	<b>155</b>
<b>Speedometer &amp; Parts</b>	<b>208</b>
Cable	208





Lubricant .....	208
Driven Gear .....	208
Retainer .....	208
<b>Spinners .....</b>	<b>156</b>
<b>Splash Shield:</b>	
Generator .....	194
<b>Spotlight .....</b>	<b>112</b>
<b>Stabilizer Bar Parts .....</b>	<b>168</b>
<b>Starter: .....</b>	<b>196</b>
Cable Bracket & Grommet .....	196
Decals .....	99
Drive .....	197
Rebuild Kit .....	1970
Relay .....	197
<b>Starter to Bell Housing Seal .....</b>	<b>197</b>
<b>Steering Column &amp; Gearbox Parts .....</b>	<b>165-167</b>
Bearing .....	165
Sleeve .....	165
Seal .....	165
Shaft Bushing .....	165
<b>Steering Gearbox:</b>	
Insulator .....	165
Rebuild .....	165
Seal Kit .....	165
Sector Shaft Bearing .....	165
Bushings & Seal .....	165
Worm Roller Bearing .....	165
<b>Steering Line, Power .....</b>	<b>167</b>
<b>Steering Linkage .....</b>	<b>164</b>
<b>Stone Deflector Seals, Rear</b>	
<b>Bumper .....</b>	<b>225</b>
<b>Striker Plate, Door Latch .....</b>	<b>226</b>
<b>Strut Rod Bushing Kit .....</b>	<b>168</b>
<b>Stud, Wheel .....</b>	<b>156</b>
<b>Sun Visors .....</b>	<b>145</b>
Anchor Pin .....	145
Arm & Bracket Assembly .....	145
Hardware .....	243
Tip .....	145
<b>Switches:</b>	
Back-up Light .....	183
Convertible Top Limit .....	148
Courtesy Light .....	210
Headlight .....	209
Dimmer .....	209
Ignition .....	208
Stop Light .....	210
Turn Signal .....	209

## T

<b>Tab &amp; Bolt Kit, Exhaust Manifold</b>	
<b>Lock .....</b>	<b>180</b>
<b>Tag, Air Conditioner Hose .....</b>	<b>98</b>
<b>Tail Lights &amp; Parts .....</b>	<b>202-203</b>
Body to Door Pad .....	202
Bucket .....	202
Retainer .....	202
Housing to Body Pad .....	202
Lens .....	202
Bezel .....	203
Trim .....	203
Socket .....	202
<b>Tank, Gas .....</b>	<b>189</b>
Filler Door Bumper .....	189
Filler Neck to Body Seal .....	189
Gauge Sending Unit .....	189
Hardware .....	189
Neck Grommet .....	189
Neck "O" ring .....	189

Sending Unit Filter .....	190
Sending Unit Float .....	190
Sending Unit Lock Ring .....	190
Sending Unit "O" ring .....	190
<b>Tee, Windshield Washer Hose .....</b>	<b>213</b>
<b>Tee-shirts .....</b>	<b>128-129</b>
<b>Temperature Sending Unit, Water .....</b>	<b>185</b>
<b>Thermostat .....</b>	<b>187</b>
Gasket .....	187
<b>Throwout Bearing, Clutch .....</b>	<b>183</b>
Hub .....	183
<b>Tie Rod .....</b>	<b>164</b>
Connecting Sleeve .....	164
End Cup .....	164
<b>Timing Chains &amp; Gears .....</b>	<b>176</b>
Timing Cover Gasket Set .....	178
<b>Tires .....</b>	<b>239</b>
Cover, Spare .....	153
Pressure (Glove Box) Decals .....	100
Spare (Wheel) Hold Down .....	151
<b>Tonneau Cover Parts .....</b>	<b>150</b>
<b>Tools .....</b>	<b>112, 119</b>
<b>Transistorized Ignition Decals .....</b>	<b>99</b>
<b>Transmission, Automatic:</b>	
Extension Housing Bushing .....	184
Gasket .....	184
Seal .....	184
Fluid Dipstick .....	184
Kick Down Rod Return Spring .....	185
Manual Control Lever Oil Seal .....	185
Pan Gasket .....	185
Screen & Pan Gasket Kit .....	184
Shift Modulator Valve .....	185
<b>Transmission, Manual:</b>	
Extension Housing Bushing .....	183
Extension Housing Seal .....	183
Gasket Set .....	183
Overdrive Housing Bushing .....	183
Overdrive Housing Seal .....	183
<b>Transmission Mount .....</b>	<b>170</b>
<b>Transmission &amp; Engine Rebuilding</b>	
<b>Books .....</b>	<b>108</b>
<b>Tray, Battery .....</b>	<b>196</b>
<b>Trim, Sealant &amp; Body Assembly</b>	
<b>Manuals .....</b>	<b>104</b>
<b>Trim Panel, Interior .....</b>	<b>142-144</b>
<b>Trim &amp; Moulding Hardware .....</b>	<b>244</b>
<b>Trunk Parts .....</b>	<b>151-153</b>
Decals .....	100
Drain Hose .....	151
Drain Trough, Convertible .....	149
Floor Patch Panels .....	236
Hardware .....	244
Interior .....	153
Fasteners .....	153
Lid (Deck):	
Bumper .....	151
Seal .....	151
to Rear Body Panel Seal .....	151
Light Kit .....	151
Lock Base Gasket .....	152
Lock Cylinder & Keys .....	151
Lock Extension .....	152
Lock Ornament Assembly .....	152
Insert .....	152
Key Hole Cover .....	152
Spring .....	152
Weatherstrip Kit,	
Convertible .....	149

## Turn Signal:

Flasher .....	209
Indicator, Fender Top .....	232
Lever .....	210
Sequencer Kit .....	210
Switch .....	209
Cancelling Cam .....	209
Pawl Spring .....	209

## U

<b>U-bolt .....</b>	<b>169</b>
<b>Universal Joints .....</b>	<b>169</b>
<b>Upholstery</b>	
Armrest Covers .....	144
Carpets .....	147
Door Trim Panels .....	142-143
Floor Mats .....	146-147
Headliners .....	144
Interior Kick Panels .....	140
Seat Covers .....	132-138
Quarter Trim Panels .....	144
Windlace .....	141

## V

### Valve:

Automatic Transmission Shift	
Modulator .....	185
Control .....	167
Exhaust .....	173-175
Heater Hot Water Control .....	218
Heat Riser .....	180
Intake .....	173-175
PCV .....	179
Stem Caps .....	121
<b>Valve Cover Gasket Set .....</b>	<b>178</b>

### Vent:

Bar Channel .....	222
Seal .....	222
Drain Tube .....	210
Window Deflector .....	214
Window Parts & Seals .....	222
<b>Vibration Damper, Crankshaft .....</b>	<b>176</b>
<b>Vinyl Top .....</b>	<b>225</b>
<b>Visor, Sun .....</b>	<b>145</b>
Anchor Pin .....	145
Arm & Bracket Assembly .....	145
Clip .....	145
Hardware .....	243
Tip .....	145

### Voltage Regulator:

Alternator .....	195
Plug & Wires .....	195
Decals .....	99
Generator .....	194

### Voltage Regulator, Instrument

Cluster .....	208
---------------	-----

## W

<b>Washer Bag, Windshield .....</b>	<b>214</b>
Bracket .....	214
<b>Washer Hose Tee .....</b>	<b>213</b>
<b>Washer Pump, Windshield .....</b>	<b>213</b>
<b>Washer Switch Housing .....</b>	<b>214</b>
<b>Water Blade .....</b>	<b>113</b>
<b>Water Pumps .....</b>	<b>187</b>
Bypass Hose .....	187
Bypass Tube .....	187
Outlet Cap .....	187



Pulley Spacer ..... 187  
 to Block Gasket ..... 187  
**Water Temperature Sending Unit..... 185**  
**Weatherstrip, Belt ..... 223**  
**Welding & Sheetmetal Books..... 107**  
**Wheel:**  
 Bearing ..... 157  
 Gasket, Backing Plate ..... 157  
 Cover & Emblem ..... 156  
 Cylinder ..... 160  
 Bleeder Screw ..... 160  
 Dollies ..... 115  
 Grease Seal ..... 157  
 Hold-down Parts, Spare ..... 151  
 Stud ..... 156  
**Wheelhouse Patch Panel ..... 237**  
**Whitewall Tire ..... 239**  
**Windlace..... 141**  
**Window Crank Handle..... 228**  
 "C-Clip" ..... 228  
 Removal Tool ..... 228  
**Window Crank Nylon Plate..... 228**  
**Window Deflector, Vent..... 214**  
**Window Hardware ..... 243**  
**Window Motor Gear..... 230**  
**Window Regulator Drive**  
 Assembly Coupling ..... 230  
**Window Roller Assembly ..... 230**

**Window Seals ..... 221-225**  
 Back ..... 224  
 Back of Vent ..... 222  
 Quarter ..... 224  
 Vent ..... 222  
**Window Switch, Power:**  
 Housing ..... 229  
 Plate ..... 229  
**Windshield Hardware ..... 243**  
**Windshield Seals..... 221**  
**Windshield Washer:**  
 Bag ..... 214  
 Bracket ..... 214  
 Hose Tee ..... 213  
 Pump ..... 214  
 Switch Housing..... 214  
**Windshield Wipers & Washers..... 213-214**  
 Arm ..... 213  
 Clip ..... 213  
 Blades..... 213  
 Blade Refills..... 213  
 Hardware ..... 243  
 Knob & Shaft ..... 209  
 Motor Hydraulic Hose..... 213  
 Motor Kit ..... 213  
 Pivot Shaft Nut ..... 214  
**Windwing ..... 214**  
**Wires & Wiring Harnesses ..... 205-206**

Body ..... 206  
 Dash ..... 205  
 Ignition Coil Resistor..... 199  
 Spark Plug ..... 199  
 Separator..... 199  
**Wiring:**  
 Dash to Engine Gauge Feed ..... 205  
 Diagram Manuals ..... 105  
 Hardware ..... 241  
 Loom & Retainer..... 206  
 Overdrive Relay ..... 205  
 Power Seat..... 206  
**Wolf Whistle..... 120**  
**Worm Roller Bearing, Steering**  
 Gearbox..... 156

Dear MAC'S,  
 A while ago, we ordered two mirrors from you for the old '57 Ford. We were very pleased with the timely fashion that we received them as well as the quality of the mirrors. Thanks for the dedication.  
 Sincerely, Pat D.

MAC'S:  
 Apparantly you revised the web site today. Even better. The word search capability makes everything so much easier and the pictures help enormously. Your site is way ahead of the pack.  
 C. Gardner

To MAC'S Antique Auto Parts:  
 I received my order promptly as promised this past Friday. I look forward to using MAC'S again. It is refreshing to do business with a company that delivers what it promises. With your help I should have an easy time restoring the 1948 Ford that I have just purchased. Thanks again for your prompt and courteous attention.  
 Larry L.

LETTERS TO **MAC'S**



# Our New Building!

We're proud to unveil our newly completed state-of-the-art facility! It's 50,000 square feet of heaven for anyone who truly lives vintage Ford cars & trucks—from Model T's & Model A's to Mustang's & Mercury's.



RANDY & RICK UNPACKING

Visitors will love our huge new showroom, with an abundance of Ford parts & accessories as well as 4 of our own antique & classic cars. Customers will benefit from being able to look a part over closely before making a purchase. They'll also enjoy the rare old Ford items from MAC's extensive private collection.

Our all new, state-of-the-art warehousing system is designed to verify that parts are in stock & easy to pull for prompt filling of orders. This ensures that our customers will receive their orders faster & more accurately than ever before. Our shipping department now has the capacity to ship over 500 packages a day!

What does this mean to you? Greater product availability & faster shipping. Add to this the same great prices & customer service that MAC's is known for & we're sure to be on the top of your list for Ford Antique & Classic parts.



THE NEW SHOWROOM

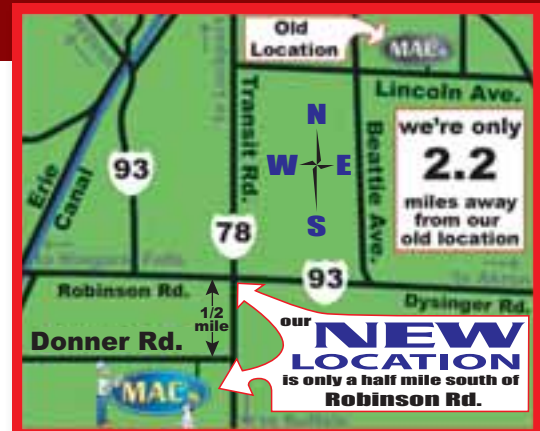

Stop by our new location, just a few minutes Northeast of Buffalo & Niagara Falls, NY.



MAC's Antique Auto Parts  
6150 Donner Road  
Lockport, NY 14094  
800-777-0948  
www.macsautoparts.com

Visit our website: [www.macsautoparts.com](http://www.macsautoparts.com) to browse or order parts.





# BROWSE...CLICK...SAVE WITH MAC'S ON-LINE!

WWW.MACSAUTO.COM YOUR ONE STOP SOURCE FOR QUALITY PARTS & ACCESSORIES FOR YOUR THUNDERBIRD.

## Ordering is easy!

After choosing the proper catalog:

1. Browse by part number or description
2. Take a closer look, many of our items have a photograph or drawing, sometimes both!
3. Check your virtual shopping cart, then check out!



Secure online ordering!

## What does the restorer in your life want?



A MAC's gift certificate is the perfect gift.



**STORE HOURS**  
8:00 AM TO 5:30 PM MONDAY - FRIDAY EST  
8:00 AM TO 12:30 PM SATURDAY EST

**PHONE HOURS**  
8:00 AM TO 11:00 PM MONDAY - FRIDAY EST  
8:00 AM TO 5:00 PM SATURDAY EST



*SORRY, NO SUNDAY SALES OR AFTER HOURS SALES.*

**When possible, place your order in advance & advise us when you plan on picking it up. It will help us & save you time!**

**C.O.D. SHIPMENTS CANNOT BE SENT OUTSIDE THE UNITED STATES!**

**If you are traveling any distance, we suggest you phone ahead to verify parts availability & store hours.**

**SEE MAP BELOW FOR DIRECTIONS TO MAC'S ANTIQUE AUTO PARTS**

**Store Address: 6150 Donner Road  
Lockport, NY 14094**

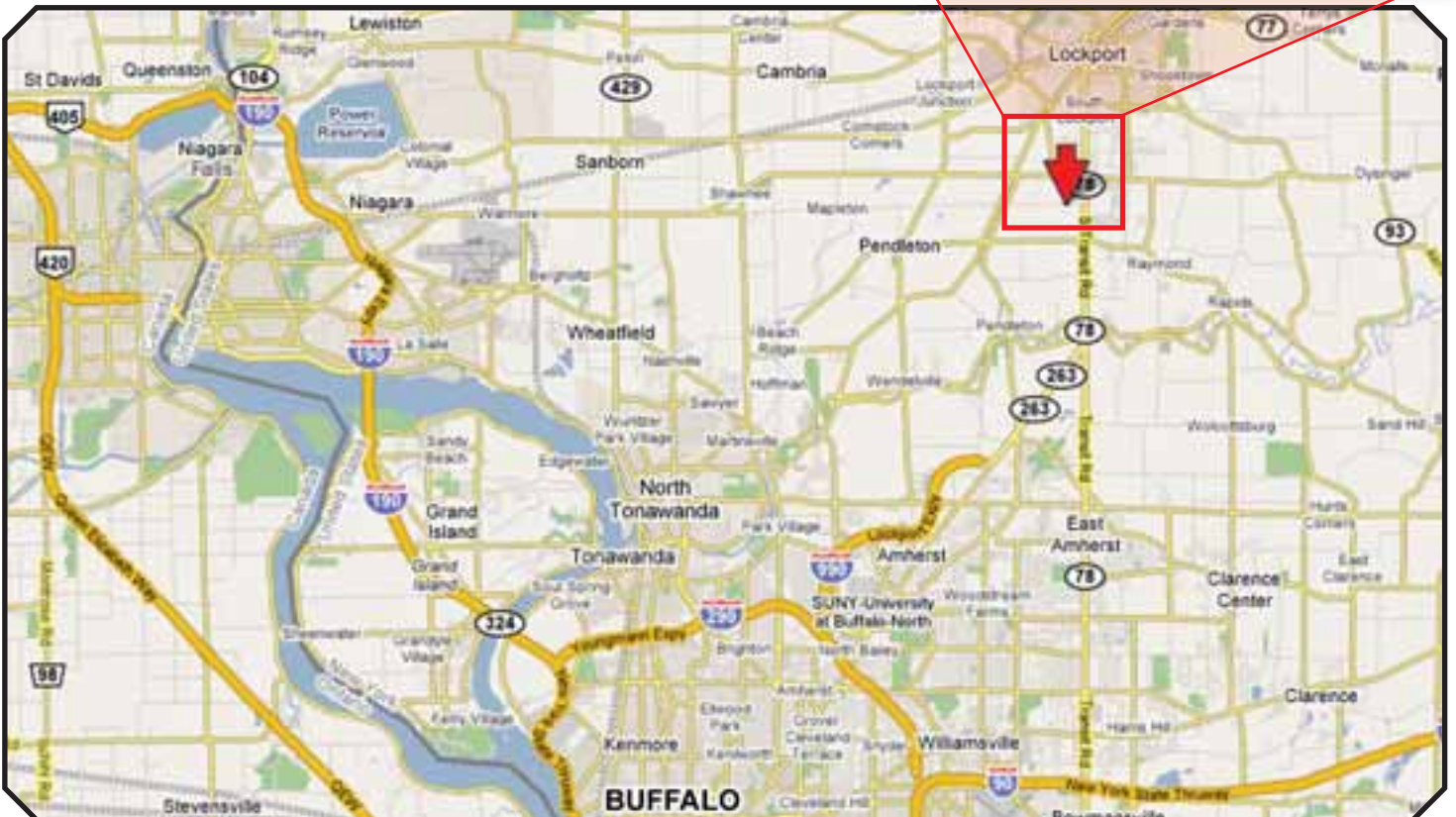
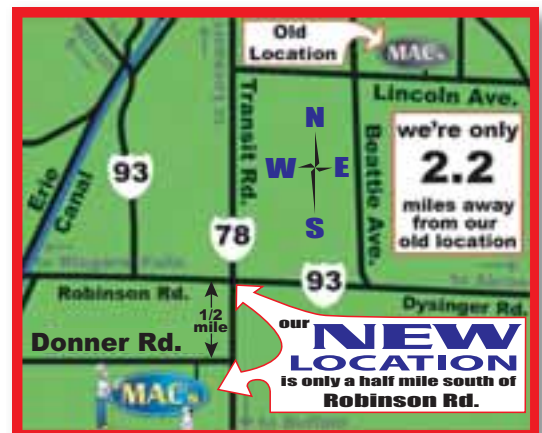





## **Ordering:**

### **Manera de engargar: Pour commander un ordre:**

We will accept orders for parts that are listed in our catalog. Orders should be filled out completely on our regular mail order form, mailed, faxed or phoned in. Fill in all the information requested.

## **Shipping:**

### **Embarque: Pour expédiér L'embarquement:**

Parts can be sent air mail. Also see "Alternate Shipping Information" below.

## **Weight:**

### **Peso: Le poids:**

In general, almost all countries will accept individual packages weighing up to 22 pounds. Many countries will accept packages up to 44 pounds. We will package your order in the required number of containers to meet these requirements.

## **Size:**

### **Dimensiones: La dimension:**

The size limits are determined by the U.S. Postal Service, not the customer's country. In general, the greatest length cannot exceed 42 inches. The total length & girth combined cannot exceed 79 inches.

## **Insurance:**

### **Seguros: L'assurance:**

Air Mail Insurance is available for most countries. Individual countries have different maximum insurance limits. Insurance limits apply to each individual package, not the total order if in more than one package. All packages are automatically insured for the value of the contents where insurance is available.

## **Customs:**

### **Derechos de aduana: Bureaux des douanes:**

Customs forms are required for all packages being sent from the U.S. We will automatically fill out & attach the required forms. The customer is responsible for paying all duties, fees & taxes levied by their country. Values will not be altered on Customs documents.

## **Postage:**

### **Derechos de correo: Frais de poste:**

All postage fees charged by the Postal Service are based on actual weight. As a means of estimating the postage required, we have devised the chart below. These are estimated amounts. Actual postage will be charged. Any shortage will be billed. Any excess will be held as a credit to apply to a future order—we do not give refunds on international orders.

## **Estimated International Postage Charges**

	Air	Air	Air
Up to \$20.00	\$24.00	\$40.01 to \$60.00	\$40.00
\$20.01 to \$30.00	\$32.00	\$60.01 to \$100.00	\$44.00
\$30.01 to \$40.00	\$36.00	Over \$100.00	51%

Be sure to include extra postage for heavy or bulky items.

## **Other Charges:**

### **Derechos adicionales:**

### **Les honoraires supplémentaires:**

In addition to the postage charges above, there are two other charges, which are explained below.

## **Boxing Fee:**

### **Derechos de empaquetar mercancía:**

### **Les honoraires pour l'empaquetage:**

International shipments require special boxing & wrapping, as well as the preparation of customs documents. To simplify things, we have

established a minimum fee of \$3.00 or 5%, whichever is greater. Please add this to the above postage charges. Also include special fees for parts listed in the catalog.

## **Bank Collection Fees:**

### **Derechos de banco:**

### **La collection des honoraires par la banque:**

If your form of payment does not meet the Banking Requirements listed in the Payments Section, our bank will charge a collection fee. This fee is explained in the Payments Section. The fee is the exact amount of the bank collection fee. These fees are normally between \$15.00 & \$30.00.

## **Payments:**

### **Maneras de pagar: Les paiements:**

All payments must be in U.S. dollars. Cash, in the form of U.S. dollars, is sent at the customer's risk. All checks, money orders or drafts must be payable on an U.S. bank & have U.S. Federal Reserve Routing Numbers. These are special numbers used by the U.S. Banking System. If you cannot obtain this type of check from your bank, please include the Bank Collection Fee listed above in the "Other Charges" section. Full payment, including postage & other charges, must be included with your order. There are no open accounts or credit extended.

## **Credit Cards:**

### **Cartas de crédito: Les comptes crédites:**

We accept Visa, MasterCard, American Express, Discover & Diner's Club. Please check to be sure the cost of your order does not exceed your credit card limits. All card charges are computer authorized prior to shipping. Shipment will not be made if authorization cannot be obtained.

## **Address:**

### **Dirección: L'adresse:**

Please be sure you have included your complete address on the order form. It must include everything required for delivery in your country, including your postal code. Anything that will help insure delivery should be included. If you have a telephone, the inclusion of its complete number is required. Also include the name of the nearest international airport.

## **Alternate Shipping Information:**

### **Otras maneras de embarque: L'information relativement à autre expédition:**

Upon special request, small packages will be shipped by Express Mail. Double the shipping rate amounts shown in the Postage Chart if you want your package sent Express Mail. The fee schedule is quite expensive & should be considered only if speed is essential or the ordered items are too big for Air Mail. UPS Air Service is also available; rates vary greatly by destination.

The fee schedule for Air Freight is too complex to provide estimates.

The fee is based on a combination of weight, volume & destination.

We DO NOT ship by Ocean Freight. Crating costs, shipping costs & other problems preclude the offering of this service.

## **Catalog Requests:**

Any request for a catalog not accompanied by an order requires \$5.00 per catalog to cover postage costs. If the catalog is requested with an order, it will be included in the package at no charge.

## **MAC's Antique Auto Parts**

Fax: 1-716-210-1370

P.O. Box 238 • Lockport, NY 14095-0238

Phone: (716) 210-1340

Email: customerservice@macsauto.com

Website: www.macsautoparts.com





# THUNDERBIRD ORDER FORM 2009-10



**P.O. Box 238, Lockport, NY 14095-0238**

ORDER LINE: (U.S. or Canada) **(800) 777-0948**

Local Phone Number  
**(716) 210-1340**

24-Hour Fax:  
**(716) 210-1370**

Email:  
**customerservice@macsauto.com**

Or visit our Website  
**www.macsautoparts.com**

(Please print clearly)

Name \_\_\_\_\_ E-mail Address \_\_\_\_\_

Street \_\_\_\_\_ Customer # \_\_\_\_\_ Date \_\_\_\_\_

City \_\_\_\_\_ State \_\_\_\_\_ Area Code & Phone ( \_\_\_\_\_ ) \_\_\_\_\_

Year of vehicle \_\_\_\_\_ Body Style \_\_\_\_\_ Country \_\_\_\_\_ Zip \_\_\_\_\_

Is this your first order with MAC's? Yes  No

Payment enclosed (Bank or Postal money orders & Checks)

Please do not phone in an order for which you are mailing a check.

C.O.D. (U.S. only - certified check unless prior arrangements are made.) **NOTE: UPS charges \$9.00 per box for C.O.D.**



Card #

\_\_\_\_\_

Signature \_\_\_\_\_

Expiration Date \_\_\_\_\_

#	Part Number	Page #	Part Name	Qty.	Price Ea.	Total Amt.
1						
2						
3						
4						
5						
6						
7						
8						
9						
10						
11						
12						
13						
14						
15						
16						
17						

U.S. ORDERS BY UPS ESTIMATED	
Up to \$20.00	\$7.00
\$20.01 to \$30.00	\$8.50
\$30.01 to \$40.00	\$9.50
\$40.01 to \$60.00	\$10.50
\$60.01 to \$100.00	\$13.25
Over \$100.00	13%
<b>Add \$9.00 per box for C.O.D.!</b>	
Double the above for Parcel Post Shipping. Add extra shipping for heavy or bulky items.	
<b>SPECIAL SERVICE AVAILABLE, U.S. ORDERS ONLY</b>	
UPS 3-Day Select (Orange) Service - 2 times above	
UPS 2nd-Day Air (Blue) Service - 4 times above	
UPS Next Day Air (Red) Service - 6 times above	

INTERNATIONAL ORDERS BY AIR MAIL ESTIMATED	
Up to \$20.00	\$24.00
\$20.01 to \$30.00	\$32.00
\$30.01 to \$40.00	\$36.00
\$40.01 to \$60.00	\$40.00
\$60.01 to \$100.00	\$44.00
Over \$100.00	51%
<b>All payments must be made in U.S. funds. We cannot accept international personal checks. All credit card numbers are computer authorized.</b>	
Air Mail is default when not stated. International boxing fee add \$3.00 or 5%, whichever is greater. See details on International Information page in catalog.	

Parts Total	
<b>MINIMUM ORDER FEE</b> Applies to orders less than \$20.00 (does not include shipping fees)	<b>\$2.00</b>
<b>ESTIMATED SHIPPING</b> See chart at left	
<b>SPECIAL BOXING FEE</b> Sheet metal & some parts have extra fees See catalog	
<b>UPS C.O.D. FEE</b> C.O.D. orders only	<b>\$9.00</b>
<b>SALES TAX</b> NY residents & walk-in orders	
<b>TOTAL PAYMENT</b>	

These are estimated amounts. Published shipping & calculated processing fee will be charged. Any shortage will be billed. Any excess will be refunded. Orders are shipped by the most economical means based on size, value and destination. All packages (including back orders) will incur individual shipping charges.



ORDER LINE: **(800) 777-0948** 24 Hour Fax Line: **(716) 210-1370**

Prices are each, unless otherwise noted. Prices subject to change without notice.



## MAC's ANTIQUE AUTO PARTS

2008-2009 1955-57 Little Bird & 1958-66 Big Bird Catalog

**GENERAL INFORMATION** – All items in this catalog are good quality new, rebuilt or new old stock (N.O.S.).

**MINIMUM ORDER** – While there is no minimum order, on orders totaling less than \$20.00 in parts prior to shipping & handling, there is a \$2.00 minimum order fee. This minimum order fee attempts to cover some of the costs that we—and all suppliers—incur when processing/handling your lower-dollar order. Even with advancements in direct shipping from the manufacturer or their warehouse, there is still extensive paperwork and follow-up involved.

**ORDERING INSTRUCTIONS** – All orders are shipped by United Parcel Service (UPS). Parcel Post shipping in the U.S. is by request only or to addresses without street addresses. Oversize orders shipped by truck will be shipped Freight Collect. On all orders outside the U.S., please see the International Information (on page 257). UPS weight limit in the U.S. is 150 lbs. Parcel Post weight limit in the U.S. is 70 lbs. C.O.D., MasterCard, Visa, Discover, American Express/Diner's Club and mail orders accepted. C.O.D. orders in U.S. only! C.O.D. ORDERS ARE BY CERTIFIED CHECK, BANK CHECK, OR POSTAL MONEY ORDER ONLY UNLESS PRIOR ARRANGEMENTS ARE MADE. UPS WILL NO LONGER ACCEPT CASH C.O.D. PAYMENTS. On credit card orders, we need your card number and expiration date. NEVER PHONE IN AN ORDER FOR WHICH YOU WILL BE MAILING A CHECK. Any returned check is subject to a \$35.00 fee.

**INTERNATIONAL SHIPPING** – All shipping outside continental U.S. is made by Air Parcel Post. Weight and size limits vary depending on the destination. Express mail and air freight can be used by request if available. Customs forms are required on all shipments, and all customs documents require full declared values. All payments must be payable to a U.S. bank. See International Information (on page 257) for further details. We do not ship by ocean freight.

**PRICES** – All prices in the catalog are subject to change without notice. We try to keep our prices as low as possible and hold price changes to a minimum. Prices given over the phone are current prices at the time of the request and are not to be considered quotes.

**BACK ORDERS** – All items are shipped promptly, **except** where noted "Special Order" or "Exchange Only." We will back order if the item is not in stock but is expected within 21 days. Anything can be back ordered by request. It is the customer's responsibility to keep track of back orders. The shipping charges remain the responsibility of the customer for any duplicated back orders or orders refused because they are no longer needed. If a back order is no longer needed, be sure to cancel it and avoid unnecessary shipping charges. All packages (including back orders) will incur individual shipping charges.

**RETURNED GOODS** – Parts may be returned with a valid reason within 30 days. Please write, call or email us BEFORE returning anything and state your reason for return. On any returned items that are not damaged or defective, a 12% restocking fee might be charged. When returning an item, please be sure to ENCLOSE A COPY OF THE ORIGINAL SALES INVOICE. Returns will not be processed without a copy of the invoice. All returned items must be prepaid. Our liability is limited to the purchased price paid with no liability for consequential damage or losses. For no reason will returns be accepted after one year.

**DAMAGED/MISSING GOODS** – If merchandise was damaged in shipping or parts are missing, immediately notify the carrier and file a claim. DO NOT DISCARD THE SHIPPING CONTAINER OR THE MERCHANDISE. Following this, call or write MAC's for further instructions.

**PAYABLE TO** – Money orders, bank drafts and checks should be made payable to MAC's Antique Auto Parts. U.S. funds only. New York State residents must include proper sales tax applicable to your city or county. We cannot accept international personal checks.

**TOLL FREE PHONE ORDER INSTRUCTIONS** – Before calling, completely fill out the Order Form and have all your order information ready and organized.

**TOLL FREE PHONE & PHONE HOURS** – Toll Free Phone 800-777-0948 (within U.S. and Canada) is personally answered between 8:00 a.m. & 11:00 p.m. Eastern Standard Time Monday through Friday, and 8:00 a.m.–5:00 p.m. Eastern Time on Saturday. After hours, our phone system will take your order for a catalog or parts. There is no charge to you for this call and you can get your parts faster at less cost. The MAC's Fax Line 716-210-1370 is open 24 hours a day. Also, our Website ([www.macsautoparts.com](http://www.macsautoparts.com)) is always available. For local calls and calls from outside the U.S., please call 716-210-1340. BE PREPARED WHEN PHONING IN YOUR ORDER. We need the part number, description, quantity desired and all the needed customer information.

**REFUNDS** – All refunds are issued approximately 7 days after shipping unless items are back ordered, in which case the refund, if any, will be issued approximately 7 days from the processing of the last back ordered item. Checks must be cashed within 6 months. A replacement fee of \$10.00 will apply to all uncashed or lost checks.

**BOXING FEE** – There is a \$2.00 boxing fee added to each order.

**SHIPPING FEES** – These are shown in the chart on the Order Form. They are estimated only, and actual charges will depend upon weight and destination. ALWAYS INCLUDE EXTRA SHIPPING FOR HEAVY OR BULKY ITEMS. Excess amounts will be refunded. See International Information (on page 242) for details on foreign shipping costs.

**NEW YORK STATE SALES TAX** – All parts picked up at our store or delivered in N.Y. State are subject to the N.Y. State Sales Tax regardless of where you live, unless you have a N.Y. Resale # or Exempt # ON FILE at MAC's. Tax is calculated on the total of your order, including boxing and shipping.

**MAILING ADDRESS** – MAC's Antique Auto Parts, P.O. Box 238, Lockport, New York 14095-0238.

**SHIPPING ADDRESS** – MAC's Antique Auto Parts, 6150 Donner Road, Lockport, New York 14094.

# THUNDERBIRD ORDER FORM 2009-10



**P.O. Box 238, Lockport, NY 14095-0238**

ORDER LINE: (U.S. or Canada) **(800) 777-0948**

Local Phone Number  
**(716) 210-1340**

24-Hour Fax:  
**(716) 210-1370**

Email:  
**customerservice@macsauto.com**

Or visit our Website  
**www.macsautoparts.com**

(Please print clearly)

Name \_\_\_\_\_ E-mail Address \_\_\_\_\_

Street \_\_\_\_\_ Customer # \_\_\_\_\_ Date \_\_\_\_\_

City \_\_\_\_\_ State \_\_\_\_\_ Area Code & Phone ( \_\_\_\_\_ ) \_\_\_\_\_

Year of vehicle \_\_\_\_\_ Body Style \_\_\_\_\_ Country \_\_\_\_\_ Zip \_\_\_\_\_

Is this your first order with MAC's? Yes  No

Payment enclosed (Bank or Postal money orders & Checks) *Please do not phone in an order for which you are mailing a check.*

C.O.D. (U.S. only - certified check unless prior arrangements are made.) **NOTE: UPS charges \$9.00 per box for C.O.D.**

Card #

Signature \_\_\_\_\_ Expiration Date \_\_\_\_\_

#	Part Number	Page #	Part Name	Qty.	Price Ea.	Total Amt.
1						
2						
3						
4						
5						
6						
7						
8						
9						
10						
11						
12						
13						
14						
15						
16						
17						

U.S. ORDERS BY UPS ESTIMATED	
Up to \$20.00	\$7.00
\$20.01 to \$30.00	\$8.50
\$30.01 to \$40.00	\$9.50
\$40.01 to \$60.00	\$10.50
\$60.01 to \$100.00	\$13.25
Over \$100.00	13%
<b>Add \$9.00 per box for C.O.D.!</b>	
Double the above for Parcel Post Shipping. Add extra shipping for heavy or bulky items.	
<b>SPECIAL SERVICE AVAILABLE, U.S. ORDERS ONLY</b>	
UPS 3-Day Select (Orange) Service - 2 times above	
UPS 2nd-Day Air (Blue) Service - 4 times above	
UPS Next Day Air (Red) Service - 6 times above	

INTERNATIONAL ORDERS BY AIR MAIL ESTIMATED	
<b>AIR</b>	
Up to \$20.00	\$24.00
\$20.01 to \$30.00	\$32.00
\$30.01 to \$40.00	\$36.00
\$40.01 to \$60.00	\$40.00
\$60.01 to \$100.00	\$44.00
Over \$100.00	51%
<b>All payments must be made in U.S. funds. We cannot accept international personal checks. All credit card numbers are computer authorized.</b>	
Air Mail is default when not stated. International boxing fee add \$3.00 or 5%, whichever is greater. See details on International Information page in catalog.	

Parts Total	
<b>MINIMUM ORDER FEE</b> Applies to orders less than \$20.00 (does not include shipping fees)	<b>\$2.00</b>
<b>ESTIMATED SHIPPING</b> See chart at left	
<b>SPECIAL BOXING FEE</b> Sheet metal & some parts have extra fees See catalog	
<b>UPS C.O.D. FEE</b> C.O.D. orders only	<b>\$9.00</b>
<b>SALES TAX</b> NY residents & walk-in orders	
<b>TOTAL PAYMENT</b>	

These are estimated amounts. Published shipping & calculated processing fee will be charged. Any shortage will be billed. Any excess will be refunded. Orders are shipped by the most economical means based on size, value and destination. All packages (including back orders) will incur individual shipping charges.



ORDER LINE: **(800) 777-0948** 24 Hour Fax Line: **(716) 210-1370**

Prices are each, unless otherwise noted. Prices subject to change without notice.





## MAC's ANTIQUE AUTO PARTS

2008-2009 1955-57 Little Bird & 1958-66 Big Bird Catalog

**GENERAL INFORMATION** – All items in this catalog are good quality new, rebuilt or new old stock (N.O.S.).

**MINIMUM ORDER** – While there is no minimum order, on orders totaling less than \$20.00 in parts prior to shipping & handling, there is a \$2.00 minimum order fee. This minimum order fee attempts to cover some of the costs that we—and all suppliers—incur when processing/handling your lower-dollar order. Even with advancements in direct shipping from the manufacturer or their warehouse, there is still extensive paperwork and follow-up involved.

**ORDERING INSTRUCTIONS** – All orders are shipped by United Parcel Service (UPS). Parcel Post shipping in the U.S. is by request only or to addresses without street addresses. Oversize orders shipped by truck will be shipped Freight Collect. On all orders outside the U.S., please see the International Information (on page 257). UPS weight limit in the U.S. is 150 lbs. Parcel Post weight limit in the U.S. is 70 lbs. C.O.D., MasterCard, Visa, Discover, American Express/Diner's Club and mail orders accepted. C.O.D. orders in U.S. only! C.O.D. ORDERS ARE BY CERTIFIED CHECK, BANK CHECK, OR POSTAL MONEY ORDER ONLY UNLESS PRIOR ARRANGEMENTS ARE MADE. UPS WILL NO LONGER ACCEPT CASH C.O.D. PAYMENTS. On credit card orders, we need your card number and expiration date. NEVER PHONE IN AN ORDER FOR WHICH YOU WILL BE MAILING A CHECK. Any returned check is subject to a \$35.00 fee.

**INTERNATIONAL SHIPPING** – All shipping outside continental U.S. is made by Air Parcel Post. Weight and size limits vary depending on the destination. Express mail and air freight can be used by request if available. Customs forms are required on all shipments, and all customs documents require full declared values. All payments must be payable to a U.S. bank. See International Information (on page 257) for further details. We do not ship by ocean freight.

**PRICES** – All prices in the catalog are subject to change without notice. We try to keep our prices as low as possible and hold price changes to a minimum. Prices given over the phone are current prices at the time of the request and are not to be considered quotes.

**BACK ORDERS** – All items are shipped promptly, **except** where noted "Special Order" or "Exchange Only." We will back order if the item is not in stock but is expected within 21 days. Anything can be back ordered by request. It is the customer's responsibility to keep track of back orders. The shipping charges remain the responsibility of the customer for any duplicated back orders or orders refused because they are no longer needed. If a back order is no longer needed, be sure to cancel it and avoid unnecessary shipping charges. All packages (including back orders) will incur individual shipping charges.

**RETURNED GOODS** – Parts may be returned with a valid reason within 30 days. Please write, call or email us BEFORE returning anything and state your reason for return. On any returned items that are not damaged or defective, a 12% restocking fee might be charged. When returning an item, please be sure to ENCLOSE A COPY OF THE ORIGINAL SALES INVOICE. Returns will not be processed without a copy of the invoice. All returned items must be prepaid. Our liability is limited to the purchased price paid with no liability for consequential damage or losses. For no reason will returns be accepted after one year.

**DAMAGED/MISSING GOODS** – If merchandise was damaged in shipping or parts are missing, immediately notify the carrier and file a claim. DO NOT DISCARD THE SHIPPING CONTAINER OR THE MERCHANDISE. Following this, call or write MAC's for further instructions.

**PAYABLE TO** – Money orders, bank drafts and checks should be made payable to MAC's Antique Auto Parts. U.S. funds only. New York State residents must include proper sales tax applicable to your city or county. We cannot accept international personal checks.

**TOLL FREE PHONE ORDER INSTRUCTIONS** – Before calling, completely fill out the Order Form and have all your order information ready and organized.

**TOLL FREE PHONE & PHONE HOURS** – Toll Free Phone 800-777-0948 (within U.S. and Canada) is personally answered between 8:00 a.m. & 11:00 p.m. Eastern Standard Time Monday through Friday, and 8:00 a.m.–5:00 p.m. Eastern Time on Saturday. After hours, our phone system will take your order for a catalog or parts. There is no charge to you for this call and you can get your parts faster at less cost. The MAC's Fax Line 716-210-1370 is open 24 hours a day. Also, our Website ([www.macsautoparts.com](http://www.macsautoparts.com)) is always available. For local calls and calls from outside the U.S., please call 716-210-1340. BE PREPARED WHEN PHONING IN YOUR ORDER. We need the part number, description, quantity desired and all the needed customer information.

**REFUNDS** – All refunds are issued approximately 7 days after shipping unless items are back ordered, in which case the refund, if any, will be issued approximately 7 days from the processing of the last back ordered item. Checks must be cashed within 6 months. A replacement fee of \$10.00 will apply to all uncashed or lost checks.

**BOXING FEE** – There is a \$2.00 boxing fee added to each order.

**SHIPPING FEES** – These are shown in the chart on the Order Form. They are estimated only, and actual charges will depend upon weight and destination. ALWAYS INCLUDE EXTRA SHIPPING FOR HEAVY OR BULKY ITEMS. Excess amounts will be refunded. See International Information (on page 242) for details on foreign shipping costs.

**NEW YORK STATE SALES TAX** – All parts picked up at our store or delivered in N.Y. State are subject to the N.Y. State Sales Tax regardless of where you live, unless you have a N.Y. Resale # or Exempt # ON FILE at MAC's. Tax is calculated on the total of your order, including boxing and shipping.

**MAILING ADDRESS** – MAC's Antique Auto Parts, P.O. Box 238, Lockport, New York 14095-0238.

**SHIPPING ADDRESS** – MAC's Antique Auto Parts, 6150 Donner Road, Lockport, New York 14094.

# THUNDERBIRD ORDER FORM 2009-10



**P.O. Box 238, Lockport, NY 14095-0238**

ORDER LINE: (U.S. or Canada) **(800) 777-0948**

Local Phone Number  
**(716) 210-1340**

24-Hour Fax:  
**(716) 210-1370**

Email:  
**customerservice@macsauto.com**

Or visit our Website  
**www.macsautoparts.com**

(Please print clearly)

Name \_\_\_\_\_ E-mail Address \_\_\_\_\_

Customer # \_\_\_\_\_ Date \_\_\_\_\_

Street \_\_\_\_\_ Area Code & Phone ( \_\_\_\_\_ ) \_\_\_\_\_

City \_\_\_\_\_ State \_\_\_\_\_ Country \_\_\_\_\_ Zip \_\_\_\_\_

Year of vehicle \_\_\_\_\_ Body Style \_\_\_\_\_ Is this your first order with MAC's? Yes  No

Payment enclosed (Bank or Postal money orders & Checks)

Please do not phone in an order for which you are mailing a check.

C.O.D. (U.S. only - certified check unless prior arrangements are made.) **NOTE: UPS charges \$9.00 per box for C.O.D.**



Card #

\_\_\_\_\_

Signature \_\_\_\_\_

Expiration Date \_\_\_\_\_

#	Part Number	Page #	Part Name	Qty.	Price Ea.	Total Amt.
1						
2						
3						
4						
5						
6						
7						
8						
9						
10						
11						
12						
13						
14						
15						
16						
17						

U.S. ORDERS BY UPS ESTIMATED	
Up to \$20.00	\$7.00
\$20.01 to \$30.00	\$8.50
\$30.01 to \$40.00	\$9.50
\$40.01 to \$60.00	\$10.50
\$60.01 to \$100.00	\$13.25
Over \$100.00	13%
<b>Add \$9.00 per box for C.O.D.!</b>	
Double the above for Parcel Post Shipping. Add extra shipping for heavy or bulky items.	
<b>SPECIAL SERVICE AVAILABLE, U.S. ORDERS ONLY</b>	
UPS 3-Day Select (Orange) Service - 2 times above	
UPS 2nd-Day Air (Blue) Service - 4 times above	
UPS Next Day Air (Red) Service - 6 times above	

INTERNATIONAL ORDERS BY AIR MAIL ESTIMATED	
<b>AIR</b>	
Up to \$20.00	\$24.00
\$20.01 to \$30.00	\$32.00
\$30.01 to \$40.00	\$36.00
\$40.01 to \$60.00	\$40.00
\$60.01 to \$100.00	\$44.00
Over \$100.00	51%
<b>All payments must be made in U.S. funds. We cannot accept international personal checks. All credit card numbers are computer authorized.</b>	
Air Mail is default when not stated. International boxing fee add \$3.00 or 5%, whichever is greater. See details on International Information page in catalog.	

Parts Total	
<b>MINIMUM ORDER FEE</b> Applies to orders less than \$20.00 (does not include shipping fees)	<b>\$2.00</b>
<b>ESTIMATED SHIPPING</b> See chart at left	
<b>SPECIAL BOXING FEE</b> Sheet metal & some parts have extra fees See catalog	
<b>UPS C.O.D. FEE</b> C.O.D. orders only	<b>\$9.00</b>
<b>SALES TAX</b> NY residents & walk-in orders	
<b>TOTAL PAYMENT</b>	

These are estimated amounts. Published shipping & calculated processing fee will be charged. Any shortage will be billed. Any excess will be refunded. Orders are shipped by the most economical means based on size, value and destination. All packages (including back orders) will incur individual shipping charges.



ORDER LINE: **(800) 777-0948** 24 Hour Fax Line: **(716) 210-1370**

Prices are each, unless otherwise noted.  
Prices subject to change without notice.







# Lost?



A separate index for each of our major catalog sections are located at the pages listed below:

- 55-57 Little Bird . . . . . 1-87 (parts) 88-94 (index)*
- Decals, Restoration, Books & Accessories . . . . 95-129*
- 58-66 Big Bird . . . . . 130-245 (parts) 246-253 (index)*
- Order Forms & Information . . . . . 254-264*

## Lower Roof Side Mouldings

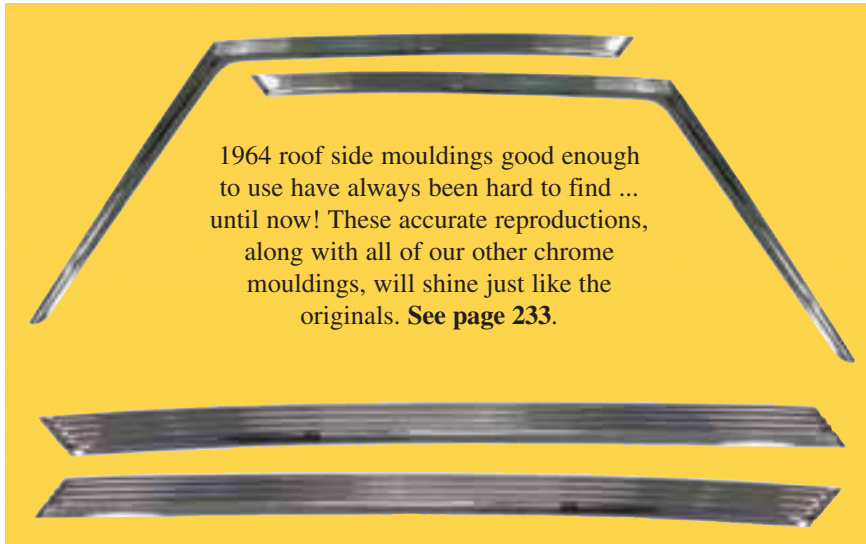

1964 roof side mouldings good enough to use have always been hard to find ... until now! These accurate reproductions, along with all of our other chrome mouldings, will shine just like the originals. See page 233.

## Headlight Door Trim

Many T-Bird aficionados love the way the 1955 Fairlane trim looks on the headlight doors & want to add it to their Little Birds. This reproduction of the original trim makes that possible. Call us today & place an order for our new headlight door trim. See page 82.



B5A-13063-E

## Do You Own Another Classic Ford or Mercury? Get Your FREE Fully Illustrated Catalog Today!

- Model T & TT 1909–1927 • Model A & AA & Street Rod 1928–1931 •
- Ford Early V8 & Street Rod 1932–1948 • Full-Size Ford/Mercury 1949–1959 & Edsel 1958–1960 • Little Bird 1955–1957 & Big Bird 1958–1966 • Ford Falcon & Mercury Comet 1960–1970 •
- Pickup Trucks 1948–1979 & Econoline 1961–1967 & Bronco 1966–1979 •
- Full-Size Ford & Mercury Cars 1960–1972 • Ford Fairlane & Torino 1962–1971 •
- Mustang 1964½–1973 •



ANTIQUE AUTO PARTS

# 1955–1966 THUNDERBIRD



OFFICIAL LICENSEE OF  
FORD MOTOR COMPANY  
TRADEMARK PARTS



order at 800-777-0948 or  
[www.macsautoparts.com](http://www.macsautoparts.com)



# The Most Complete Selection of Parts for Your 1955-66 Thunderbird



Enjoy easy search,  
online specials &  
the widest selection at  
**WWW.  
macsautoparts.  
com**

CATALOG CODE  
BMAC09

**U.S. & Canada  
800-777-0948**



B5A-13450-AR

B6A-13450-AR

B7A-13450-BR

## Brighten Your Outlook

Replace those old, faded lenses with these brand new reproductions, complete with the "FoMoCo" logo. Along with new bulbs, gaskets & connectors, you'll brighten your 'Bird's future. See page 57 or 202.



B5S-18806-CA1

## MAC's Keeps You Tuned In

Our USA-1 AM/FM cassette stereo radio kicks out 200 watts of power, a chrome nosepiece, reproduction knobs & 12 more features that any music enthusiast would put on his wish list. Get today's sound out of your original dash! See page 19 & 155.



## Don't Avoid These Carbs

MAC's offers remanufactured carburetors for many Thunderbird models. After you receive your rebuilt carb, just send us your old one. See page 191.

Great Quality  
and  
Service

Fast Shipping  
for  
30 Years