

Reamers, Gauges and Associated Tooling for the Gunsmith and Manufacturer

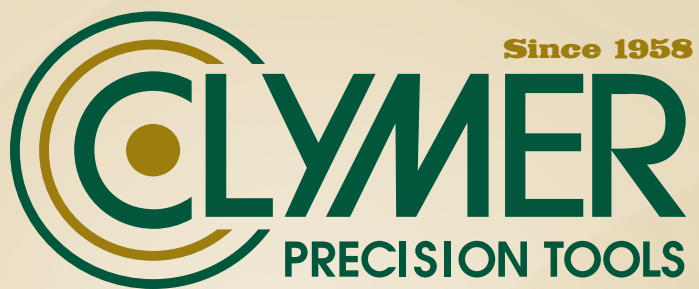

Product Catalog

OUR NEW CATALOG

Dear Valued Customer,

We want to thank you for your interest in Clymer Manufacturing and our new catalog. Throughout the shooting industry, Clymer Reamers and Head Space Gauges are synonymous with precision tooling, close tolerances, and accurate firearms. We have been building this reputation since 1958, working diligently to maintain our high standards of quality.

The growth of Clymer Manufacturing continues today with the dedication and commitment of our entire staff. We strive for manufacturing excellence and efficiency in each and every product we offer. Our goal is to provide you with the highest quality precision tooling at fair prices with first-rate, dependable service.

One glance through our new catalog and you will notice that we are as passionate as ever about the tools you need and we proudly make. You will be hard pressed to find a better selection of reamers, gauges, and associated gunsmith tooling anywhere. Whether you are new to gunsmithing or an experienced professional, we hope the information we have included will aid you in your work for many years to come.

We are eager to work with you to help you determine which tools are right for your project, depending on your specific needs. Whether your interest is in our standard or special tools, we encourage you to contact us with your orders, questions and ideas. (Many of the items within our catalog are a direct result of customer input.) Our company is ready to service your needs and as always, we continue to stand behind all of our products.

As we look forward to the future here at Clymer we would like to thank you, our loyal customer, for your support over the years. We appreciate and value your trust and are focused on providing the best possible products and services.

On behalf of our entire team, thank you for learning more about the tooling that Clymer Manufacturing is building for you. We look forward to hearing from you soon.

Sincerely,



Todd Wilms
President

TABLE OF CONTENTS

TOOL OR SERVICE	PAGE NO.
Care and Use of Reamers.....	2 & 3
Rifle Chambering Reamers.....	4
308 & 30-06 Headspacing Reamers.....	5
Pistol Chambering Reamers.....	6
Shotgun Tooling.....	6, 7, 8 & 9
Headspace Gauges.....	9, 10, 11, 12, 13, 14 & 15
Wildcats/Specials.....	16, 17, 18, 19, 20 & 21
Other Cutting Tools.....	22, 23, 24 & 25
Center Drills.....	26
Accessories.....	27
Options/Alterations.....	28
Resharpening.....	29
Order and Shipping Information.....	30
Mail Order Form.....	31
Warranty.....	Back Inside Cover



CARE AND USE OF CLYMER CHAMBERING REAMERS

Care in handling chambering reamers cannot be overstressed. Always store reamers in a protected manner (plastic tubes, their shipping containers, etc.) to prevent damage to their cutting edges. If cutting edges are nicked or otherwise damaged, any chamber cut with the reamer will have rings or other surface imperfections.

Stone chambering reamers **only** to remove a nick or burr. A finish reamer which has been properly ground and cared for should cut a hundred chambers or more (depending on the method used). When dull, return the reamer to its manufacturer for re-sharpening. Clymer Manufacturing offers this service to its customers at reasonable prices - quoted in the current price list.

Before using any tool, double-check its dimensions to insure it is the tool you want to use.

When chambering by hand or in the lathe, use the best grade of cutting oil available.

Roughing reamers are usually used when many chambers are to be cut in order to reduce wear on the finisher. If only a few chambers are to be cut a finish reamer alone will suffice. **We do not recommend roughing in chambers with unpiloted tools, such as drills, since the chamber will often end up eccentric to the bore.**

Care of the reamer when cutting the chamber is also important. To prevent the flutes from becoming packed with chips, the reamer should be cleared approximately every 1/16". Brush the reamer with a small brush to remove chips, paying special attention to cleaning chips from the pilot. When cleaning chips from the reamer, check to see if any are loading up along its cutting edges. Barrel steel stuck here may be scraped off by running a piece of carbide along the face of the flutes, being careful not to roll over the cutting edges.

When testing a reamer in our shop, we hold the barrel in the headstock of the lathe, making certain the muzzle and breech ends run true. If the bore runs out, there is a good chance of breaking the reamer and/or cutting an oversize chamber. A floating reamer holder used in the tailstock lets the reamer seek the true center of the bore and helps avoid cutting the base diameter too large. When using a floating reamer holder, make sure any misalignment of the bore does not exceed the limits of "float" of the holder. As a rule of thumb, the base diameter of a fired case should be no more than .001" larger than the reamer used to cut the chamber.

When hand chambering, be sure the reamer is held true to the bore. Caution must be used since the reamer, though carefully hardened and drawn, may snap off if cocked to the side. Press down firmly on the reamer when beginning to chamber and turn slowly so the tool will not jump and chatter. Most chatter in chambering is caused by improper use of the reamer. If chatter does start, it must be removed before chambering can be completed since the reamer tends to follow the highs and lows of the chatter. Call us if this happens and we'll do our best to help.

It is a good idea to clean out all the chips in the chamber prior to final headspacing so as to avoid scoring the chamber walls. Little, if any polishing should be needed if care has been exercised during the final cuts.

CARE & USE OF CLYMER CHAMBERING REAMERS (continued)

Chamber reamers are more difficult to use than chucking reamers because of the configurations they are designed to cut. By way of comparison, a chucking reamer cuts only on its front end because its job is to create a round, straight hole, of a precise diameter. A chamber reamer also has to cut precise sizes. In addition to this requirement, it has to cut along its **entire length** because chambers are tapered for feeding purposes. This means that a chamber reamer, at the point where it is at full depth, generates 6 chips approximately 2¹/₂" long (30-06). Additionally, the different tapers and cutting diameters ground into chamber reamers require different relief angles to cut properly - consider the different sizes on a 257 Wby.

Most 'smiths realize this and it is repeated here only to emphasize that chambering reamers are complex, expensive tools, and require more care for successful use than other cutting tools. Because of the way they have to be made to cut forward tapers, new chambering reamers require a "break-in" period.

Anyone who has cut chambers will have noticed that brand new reamers rarely cut equally on all flutes. The above-mentioned break-in period occurs over the first few chambers cut by the new tool during which the cutting edges wear, microscopically, to the same height. After "break-in," all flutes will cut more-or-less equally. The reamer will also become easier to use and have less tendency to dig in.

Proper break-in of a reamer requires a sensitive touch on the part of the 'smith - push a new reamer too hard and it will wear unevenly; feed it too lightly and it may chatter. There is no hard and fast rule for the rate at which a chambering reamer should be fed.

While spindle speed is fairly standard for chambering (50-90 RPM), many variables come into play when determining how fast to feed a reamer. The amount of metal being removed (22 LR vs. 264 Win Magn), shoulder angle of the tool (25-06 vs. 25-06 Ack. Imp.), barrel material (chrome-moly vs. Stainless steel), and set-up rigidity reamers with a large difference between neck and body diameters have to be fed more slowly after the body begins to cut. Think about it - metal can be removed only so fast and more metal has to be removed with this type of tool; it therefore has to be fed more slowly. Conversely, chambering reamers for cartridges like 22 LR or 357 Magn can be fed faster because less metal is being removed.

We constantly experiment with and upgrade the reamers we manufacture in an effort to achieve the best combination of tool life and ease of use. These hints on care and use should be considered a starting point - you need to be guided by your own experience with your machinery and our reamers in deciding how to use a particular tool. If problems do occur, call us **before** you reach the point where your chambering job is ruined. Many times we can help correct a problem and save you time and frustration.

RIFLE CHAMBERING REAMERS

Rough and Finish rifle chambering reamers are available in both straight and spiral-fluted configurations. **Finish reamers**, both straight and spiral, unless ordered otherwise, come standard with an integral throat. Reamers for rimmed or belted calibers also feature a counterboring section for the rim or belt. Straight fluted **Roughing Reamers** are ground .010" under finish chamber size and do not cut any portion of the throat.

Straight fluted tools have six, right-hand cutting flutes made to a proprietary design that effectively resists chatter. Spiral fluted tools, by their nature, are chatter-resistant. Spiral finishers feature six, left-hand spiral, right-hand cutting flutes. Please contact us for pricing and availability based on your projects. Straight-fluted tools have solid pilots with removable pilots and other features available as options.

Pictures illustrating the various types of rifle chambering reamers appear below. Hints on the use and care of chambering reamers may be found on page 2. Please refer to the **Options section** for alterations/options offered on our tools.

A listing of our standard calibers is given on the current price list.

Straight, solid pilot Finish-Rimless

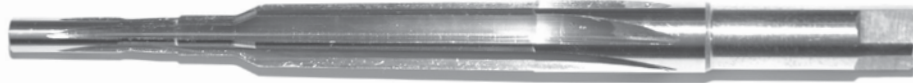

Straight, solid pilot Rough Rimmed/Belted



Removable pilot straight-fluted Reamer



308 & 30-06 HEADSPACING REAMERS

Cutting the final few thousandths of an inch to achieve minimum headspace can be a real problem. Military armorers have long used special headspacing reamers that cut only the shoulder portion of the chamber to perform this tedious job quickly and accurately. These special cutters were “loaded” into a short chambered barreled action. A drive extension running down the barrel would then be screwed into the cutter’s pilot and the tool rotated while forward pressure was applied with the bolt. Once the bolt went into battery no further forward pressure could be applied and the reamer would stop cutting. Since the distance from the base of the cutter to its shoulder matched the minimum headspace dimension for the particular chambering, the chamber would be cut to minimum headspace once the bolt had locked. Quick, easy and accurate.

Until now, few ‘smiths outside of the military could acquire one of these timesavers. Because of the demand for these tools, Clymer Manufacturing has re-introduced them for general sale. These are the same tried-and-true cutters the military has relied upon for years in setting up their competitive service rifles with **two important improvements!**

Neck & Throat Section: Until we re-designed the Headspacing Reamers, none ever pushed the neck and throat sections ahead at the same time the shoulder was moved ahead. If these sections are not moved forward with the shoulder, potentially dangerous situations can arise in which the weapon does not go fully into battery; the case neck of the cartridge could be crimped into the bullet, or the bullet could be forced into the rifling. These problems are eliminated with the CLYMER design.

Headspace Adjustment: Previous designs either made no provision for adjusting the headspace dimensions of the reamer, or, if adjustments were incorporated, they were imprecise or difficult. Clymer’s design uses a precision ground thrust Bushing between the bolt and base of the Headspacing Reamer. By interchanging Bushings of different thicknesses, different headspace dimensions may be obtained with no guesswork. This also allows the Reamer to be re-sharpened without impairing its function. Additionally the Bushing prevents the bolt face from being marked by the rotating Reamer.

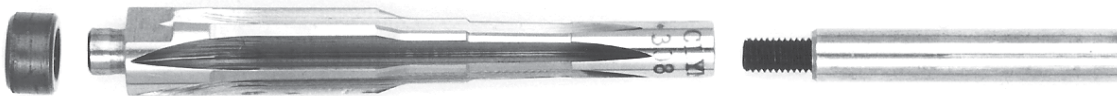

Available Immediately for 308 Win, 30-06 and 30 Carbine, Clymer Headspacing Reamers may be ordered as a complete set, or as individual components. Reamers are made from M-7 HIGH SPEED STEEL, carefully hardened and ground. Bushings and Extensions are made from Tool Steel, with the Bushings being hardened and ground to exacting dimensions.

PISTOL CHAMBERING REAMERS

Rough and Finish chambering reamers are available in the same configurations as rifle chambering reamers, WITH AN IMPORTANT DIFFERENCE - PILOT DIAMETER. If you are chambering a revolver cylinder, the pilot of the reamer must be approximately bullet diameter, since it is guided by the exit diameter of the cylinder. Reamer pilots for cutting chambers in barrels (Semi-autos, Contenders, etc.) are guided by the bore diameter (land-to-land diameter) and must be smaller to fit this section of the gun.

When ordering Pistol Chambering Reamers, please specify whether for Cylinder or Barrel use. Reamers for Cylinder use will be marked (C); tools for Barrels will be marked (B).

Pictures showing the various types of pistol chambering reamers appear below. Information on the CARE AND USE OF CHAMBERING REAMERS is found on page 2. Please refer to the OPTIONS section for alterations/options offered on our tools. Calibers that are carried in stock are listed on our current price list.

Straight, rimless, solid pilot Finisher



Straight, rimmed, solid pilot Rougher



SHOTGUN TOOLING

SHOTGUN BORE REAMERS

These tools are used for back-boring and choke modification in shotguns. The lead angle matches the angle of most chokes and will therefore blend into an existing choke when back-boring. Bore Reamers are used to alter the bore and/or the forcing of the choke.

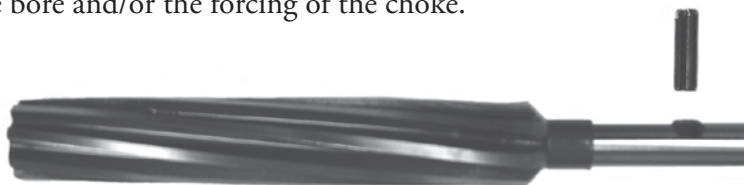

Clymer Bore Reamers are stocked in the cutting diameters listed below. Variations on our standard design are, of course, available on a special order basis.

Gauge

12 Gauge
20 Gauge

Diameters

.720 .725 .730 .735 .740
.605 .610 .615 .620 .625

PLEASE NOTE: Because these reamers should be driven as accurately as possible, we offer three (3) sizes of 34" extensions. LARGE fits the shanks of 10, 12 and 16 Gauge Bore Reamers, MEDIUM is used with 20 and 28 Gauge tools, and SMALL fits 410 ONLY.

SHOTGUN TOOLING, continued

With few exceptions, all of the reamers we make for use on shotguns feature spiral flutes. This is done for two reasons: resistance to chatter, and the superior finish given by this design.

The large diameters encountered in shotgun work have always presented chatter problems on multi-fluted tools such as chambering reamers, long forcing cone reamers, etc. This problem can be alleviated either by using tools with an odd number of flutes which, unfortunately, makes the tools difficult to measure; or by providing tools with spiral flutes. In addition to resisting chatter, spiral reamers cut with a shearing action, giving a superior surface finish which means the gunsmith has to spend less time polishing his work.

All shotgun cutting tools except for those tipped with carbide, are made from M-7 HIGH SPEED STEEL, carefully hardened and drawn to insure long life and good durability.

SHOTGUN CHAMBERING REAMERS

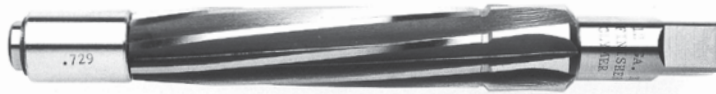

Shotgun Chambering Reamers are made with an 8° left-hand spiral configuration and a squared shank for use with a tap handle, or similar driver. Roughing reamers are supplied .010" under finish size; both rough and finish reamers cut the entire chamber, including the throat and rim recess. Please see our current pricelist for standard stocked sizes.

SHOTGUN LONG FORCING CONE REAMERS

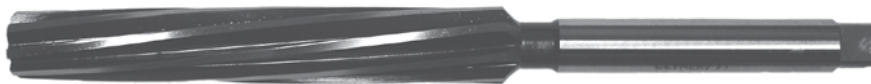

Clymer Spiral Fluted Long Forcing Cone Reamers make lengthening the forcing cone in shotguns much easier for the gunsmith. The 3½" long shank requires no extension to reach through actions and the smooth cutting flutes leave a finish that requires little, if any patterns and less felt recoil.

PROBLEMS WITH CHROME PLATED BARRELS?

Try Our **CARBIDE-TIPPED LONG FORCING CONE REAMER**



Recently developed, Clymer Manufacturing offers CARBIDE-TIPPED Long forcing Cone Reamers in 12 Gauge. Don't turn away any more work - these reamers will cut through the chrome plating found in many modern shotguns. Used just like our well-proven High Speed Reamers, a new Carbide-Tipped Long Forcing Cone Reamer will be a **profitable** addition to your toolbox. **Recommended for plated barrels only.**

All shotgun cutting tools except for those tipped with carbide, are made from M-7 HIGH SPEED STEEL, carefully hardened and drawn to insure long life and good durability.

SCREW-IN CHOKE TOOLING

Screw-in chokes have become extremely popular, and many knowledgeable gun owners are asking to have their older guns converted to this system. CLYMER MANUFACTURING makes a line of Reamers and Taps for installation of full-diameter (WinChoke-style) choke tubes, AS WELL AS tooling for thinner wall tubes made after the TruChoke Design.

RemChoke tubes have the same 13/16"-32 thread as WinChoke-style tubes and therefore use the same tap. Because the body of the RemChoke tube is longer and larger than the WinChoke, a special reamer is required to machine the barrel prior to tapping with a 13/16"-32 tap. RemChoke reamers are now available from stock. CAUTION: Because RemChokes are even larger than WinChokes, the smith must be especially careful to insure that sufficient barrel thickness remains after machining.

All Clymer Reamers and Taps are made from HIGH SPEED STEEL and have BRONZE PILOT BUSHINGS interchangeable between Reamer and Tap. Bushings are 2" long and are available in increments of .001" to insure accurate bore alignment and minimize any change in point-of-impact after installation.

Reamers are 8-fluted, right-hand cutting, left-hand spiral and have a stop which squares the end of the barrel. The leading edge of the reamer creates a shoulder within the barrel on to which the skirt of the choke tube seats. Taps are 6-fluted with ground threads made to exacting standards, and are TIN coated to extend tool life.



Thread Specifications

20 Ga. TruChoke: .675" - 44 2-start
 20 Ga. WinChoke: 11/16"-32
 12 Ga. ThinWall TruChoke: .775"-44 2-start
 12 Ga. TruChoke: .795"-44 2-start
 12 Ga. WinChoke: 13/16"-32

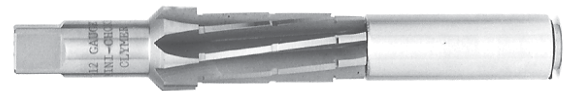

Std. Bushing Sizes

20 Gauge: .610,
 .611, .612, .613, .614
 12 Gauge: .725,
 .726, .727, .728, .729

PLEASE NOTE: RemChoke uses WinChoke tap, also special diameter bushings differing from the above can be made to order. Alternatively, the gunsmith can buy Bushing Blanks, finished on the I.D., and turn them to size using his tooling.

MUZZLE SQUARING TOOL

Developed as a result of customer demand, our MUZZLE SQUARING TOOL greatly speeds finishing off a shotgun barrel after it has been shortened. How many times have you tried to file the end of the barrel square after cutting it off with a saw only to have it get shorter and shorter?

If you've cut the barrel off in a vise, simply remove any internal burrs and select a 1" long pilot bushing that closely fits the bore. Fit the bushing to the MUZZLE SQUARE, chuck the tool in a variable speed drill motor, insert the bushing in the barrel to be squared and run the drill motor at low RPM for a second or two. The result? A nicely finished barrel end.



Designed so that one tool will accommodate 10 through 20 GA barrels, our MUZZLE SQUARING TOOL is sold without pilot bushings. Standard 1" long pilot bushings, as listed on our current pricelist, fit these tools. Alternatively, blank 1" long bushings may be purchased from us and turned to the required size. Made from HIGH SPEED STEEL, carefully hardened and ground, CLYMER MUZZLE SQUARING TOOLS are a great time saver.

55° RIM-CUTTING/HEADSPACING REAMERS

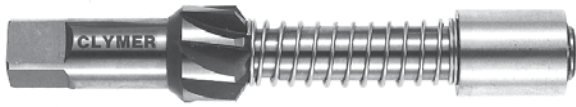

We offer this "SYSTEM" of tooling to the discriminating 'smith for cutting the 55° recess when fitting new extractors, and restoring correct headspace in guns worn beyond acceptable limits.

The "SYSTEM" consists of 55° RIM CUTTERS, available in 10, 12, 16, 20, 28, and 410 gauges. Each is made from HIGH SPEED STEEL and features a spring-loaded tapered bronze pilot bushing to compensate for differences in chamber dimensions while keeping the cutter properly centered. Right-hand cutting, right-hand spiral, cutters are odd-fluted to resist chatter.

HEADSPACING RINGS, available in the gauges listed above complete the system. These are used when restoring correct headspace in worn guns. A recess approximately 1/4" deep is first cut with the appropriate RIM CUTTER. A HEADSPACING RING is hard soldered in the recess; the RIM CUTTER or conventional chambering reamer is then used to recut the headspace to correct dimensions. Polishing out the repair makes it almost unnoticeable.

55° RIM CUTTERS and HEADSPACING RINGS are available separately, or as a set. (Instructions included.)

CLYMER HEADSPACE GAUGES

Throughout the shooting industry, Clymer Reamers and Headspace Gauges are synonymous with precision tooling, close tolerances, and accurate firearms. We are proud of this reputation and work constantly to maintain our high standards of quality. With this thought in mind, we offer the following information on our headspace gauges.

RIMMED OR BELTED CALIBERS

These gauges check headspace from a flange that duplicates the minimum and maximum space allowed in a chamber to secure the rim or belt on a cartridge. Sporting Arms and Ammunition Manufacturers, Inc. (SAAMI) generally allows .007" between the minimum and maximum safe values they have established for each caliber. Some cartridges, when used in handgun applications are allowed more than this .007" between minimum and maximum headspace. CLYMER MANUFACTURING offers "GO" and "NO-GO" gauges in our standard rimmed and belted calibers. These are precision ground as closely as possible to the established SAAMI values. We do not offer as standard gauges with wider tolerances for handgun applications, but, instead, strongly recommend that the tighter-toleranced gauges for rifle chambers be used. We will, of course, make gauges that differ from our standards on a special order basis.



Rimmed Gauges



Rimmed Shotgun Gauges



Belted Gauges

RIMLESS PISTOL GAUGES

Headspace gauges for rimless pistol cartridges that headspace off the case mouth (examples 45 ACP, 9MM Luger) are offered in "GO" and "NO-GO" configurations, which again correspond to the accepted SAAMI minimum and maximum.

RIMLESS GAUGES FOR SHOULDERED CHAMBERS

This style of gauge measures headspace from the breech face to some established point on the shoulder of the chamber. This point is referred to as the “Datum Diameter” and ultra-precise ring gauges are used to measure this dimension during manufacture. SAAMI generally allows .010” between the minimum and maximum values for rimless calibers. Clymer “GO” and “FIELD” gauges correspond to the SAAMI minimum and maximum respectively. Because many feel that .010” is too much variation between a minimum and maximum chamber, we also offer as standard a “NO-GO” gauge, which is .006” longer than our “GO”.

Rimless headspace gauges for Ackley Improved chambers are made in the same precise way as our other rimless gauges. An explanation of the principle used in headspacing Ackley Improved chambers is given below.

In the few instances where our gauge dimensions differ from SAAMI values, our gauges will always be within the SAAMI minimum and maximum and will thus provide you, the shooter, with a more precise chamber.



IMPROVED vs STANDARD CHAMBERS AND THEIR HEADSPACING

“Improved versions of standard cartridges have been more or less popular for years. In general, the “improvement” consists of increasing the shoulder angle of a standard cartridge (making it steeper), reducing the body taper of the case by blowing out the shoulder, or both. The increased capacity of the “improved” case offers higher potential bullet velocities and, according to some theories, reduced case stretch and bolt thrust. This discussion is not intended to compare the relative advantages of “improved” vs. standard chambering, but only attempts to explain the conversion of a standard chamber for a rimless, shouldered cartridge to an “improved” chamber, and the gauging (headspacing) necessary in the conversion.

In converting standard ammunition to “improved” ammo, factory brass is “fireformed”, or blown out, in a properly configured “improved” chamber. Once formed by this process, the “improved” brass is subsequently reloaded per normal practice. “Improved” chambers for belted or rimmed cartridges do not normally present headspacing problems, since the cartridge is secured by its belt or rim during fireforming and the shoulder is simply blown out and forward. The “improved” chamber headspace dimensions for belted or rimmed cartridges are the same as standard, non-“improved” chambers, and gauges for the standard chamber are used. Headspacing of rimless, “improved” chamberings do present problems since the shoulder, against which the cartridge seats during firing, is no longer at its original position and the shoulder angle does not match the factory ammo to be formed.

Please refer to Fig. 1. This sketch contrasts a standard and “improved” chamber. Note that the neck diameter of the “improved chamber” is the same as that of a standard chamber. The neck length is nominally the same, though there will be some shortening of the cartridge neck as a result of the expanding body and shoulder of the case during the fireforming.

Fig. 2 shows how neck lengths vary as a parent cartridge (in this case, a 30-06) is necked down or up to form new calibers. (25-06 & 35 Whelen).

IMPROVED vs STANDARD CHAMBERS AND THEIR HEADSPACING, continued

Fig. 3 shows how “improved” versions of different chamberings relate to their standard configurations, **as well as** the parent cartridge. Note that while the body lengths of their improved versions vary.

At this point, please refer to Fig. 4. It illustrates the manner in which a rimless, shouldered cartridge is secured in a standard as well as an improved chamber during fireforming. You will note the cartridge only makes contact with the neck/shoulder junction of the “improved” chamber rather than full shoulder contact as it would in a standard chamber. Since factory ammo varies slightly, the dimensions from the neck/shoulder junction to the breechface becomes critical during the fireforming process. In order to hold factory brass securely during fireforming, P.O. Ackley (on whose principles this discussion is based) recommends that this distance be reduced by .004” in an “improved” chamber to compensate for these variations in ammunition. Since headspace gauges for a standard chamber gauge this distance, headspace gauges **with the same shoulder angle** .004” shorter are used to gauge the breechface-to-neck/shoulder junction or “improved” chambers. **This is why our gauges for “improved” chambers are made with the same shoulder angle as headspace gauges for standard chambers.**

Summarizing to this point, headspace gauges for “improved” versions of rimless, shouldered cartridges have the following characteristics:

- The **gauge** shoulder angle is the same as the shoulder angle of the standard chamber. See Fig. 5.
- The breechface-to-neck/shoulder junction dimension is .004” **shorter** for the “GO” in an “improved” chamber. See Fig. 6.
- The “GO” gauge for the standard chamber becomes a “NO-GO” gauge for the improved chamber. This means that an “improved NO-GO” will drop in a standard chamber since it is the same length as a “GO” gauge for the standard chamber.

In practice, cutting an “improved” chamber in a barrel blank is not greatly different from cutting a standard chamber. Whether a roughing reamer is used or not, the finisher is run in until the action will just close on the appropriate “GO” gauge - in this case, an “improved GO” gauge. If an existing chamber is being altered to an “improved” configuration, however, the procedure becomes a little more involved.

As outlined previously, the distance from the breechface to the neck/shoulder junction in an “improved” chamber must be .004” **shorter** than a standard chamber in order to hold factory ammunition securely during fireforming. Since reamers can’t cut a chamber shorter, the barrel must be set back (some gunsmiths suggest setting it back one full thread so that screw holes, etc will line up properly) and the chamber re-cut so the action will just close on the “improved GO” gauge. Extra care and a light “feel” are recommended when headspacing the “improved” chambers - a look at Figs. 7 & 8 illustrates why.

Fig. 7 shows how the headspace gauge makes contact in a standard chamber. Note that it touches the shoulder of the chamber along its entire length. The headspace gauge in an “improved” chamber, however, makes only line contact with the neck/shoulder junction - Fig. 8. It is this narrow area of contact with the chamber that necessitates the light touch when headspacing “improved” chambers. One can readily imagine that a heavy hand during headspacing could “crush” the “GO” gauge into the shoulder by several thousandths of an inch, resulting in a slightly shorter chamber.

Having come this far, you may wish to read further on the subject of headspacing “improved” chambers. P.O. Ackley’s **Handbook for Shooters and Reloaders,** Vols. I & II are excellent texts and we recommend them highly.

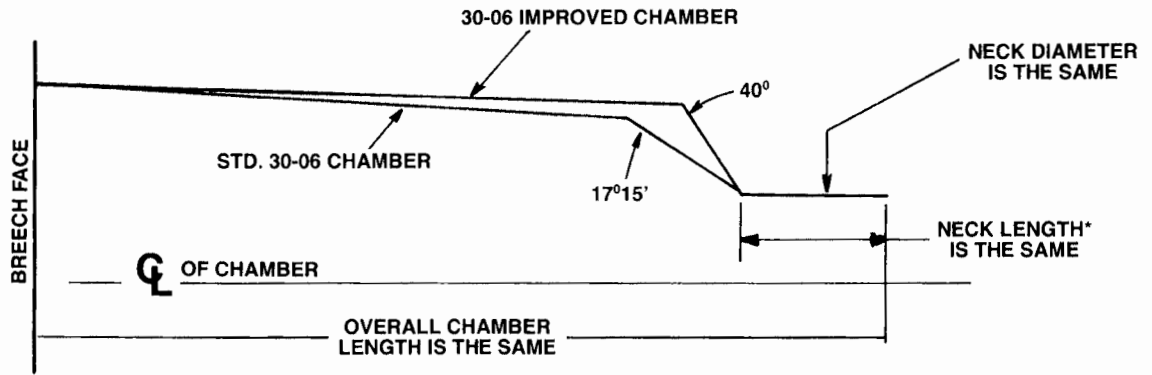

*ACTUAL NECK LENGTHS OF IMPROVED CASES WILL BE SLIGHTLY SHORTER THAN STD. DUE TO SHRINKAGE DURING FIRE-FORMING.

FIGURE 1

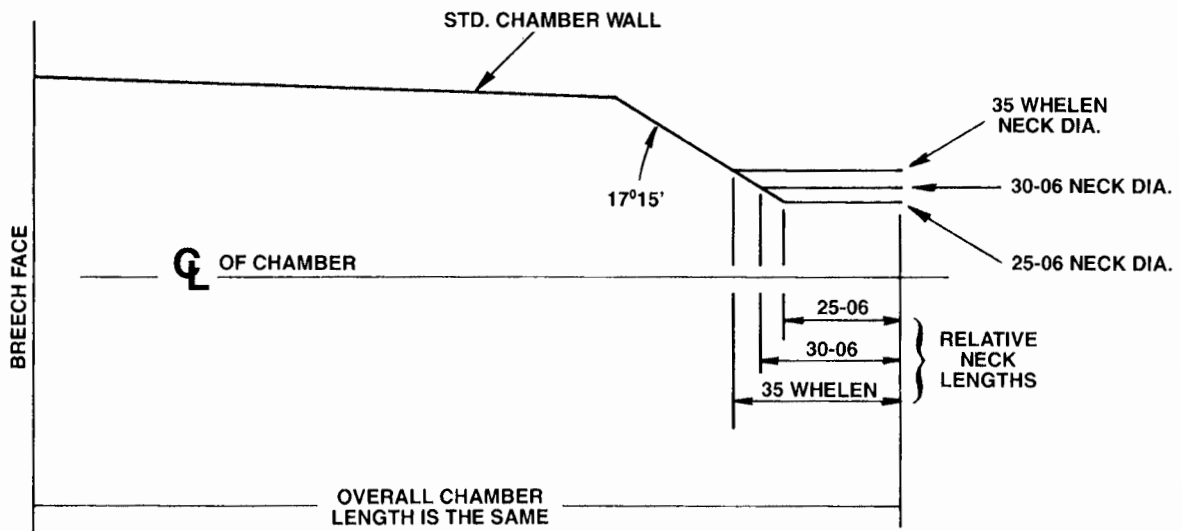

FIGURE 2



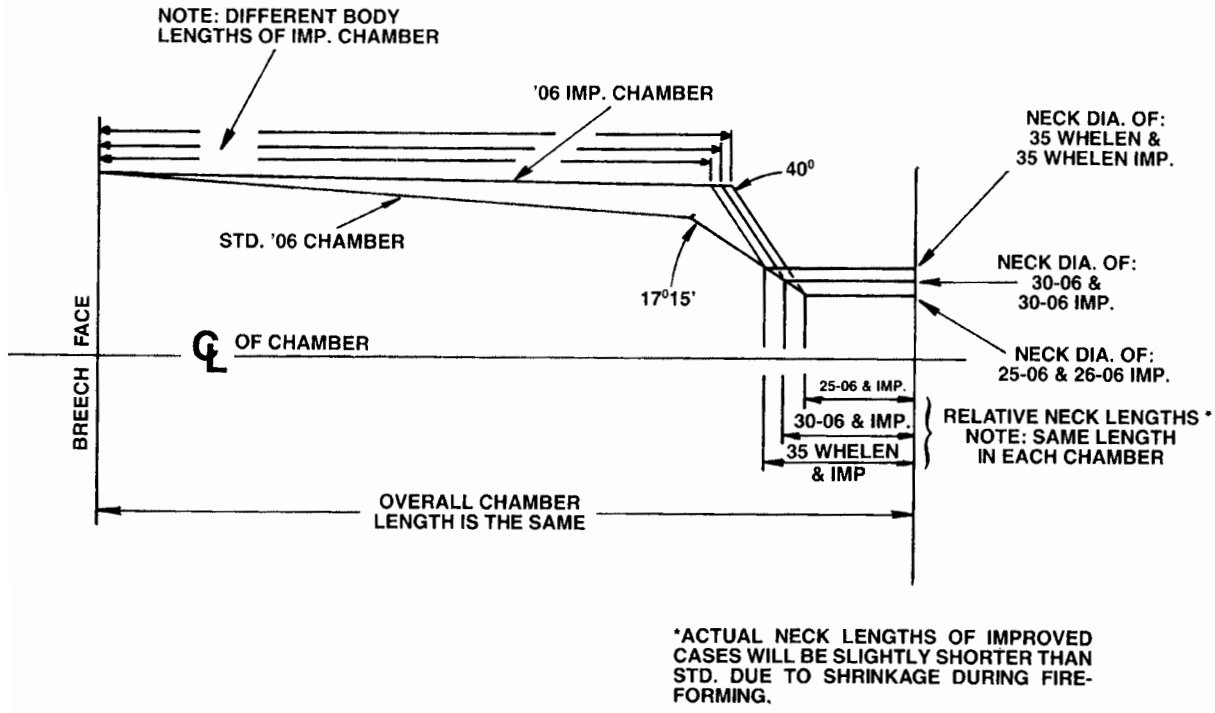

FIGURE 3

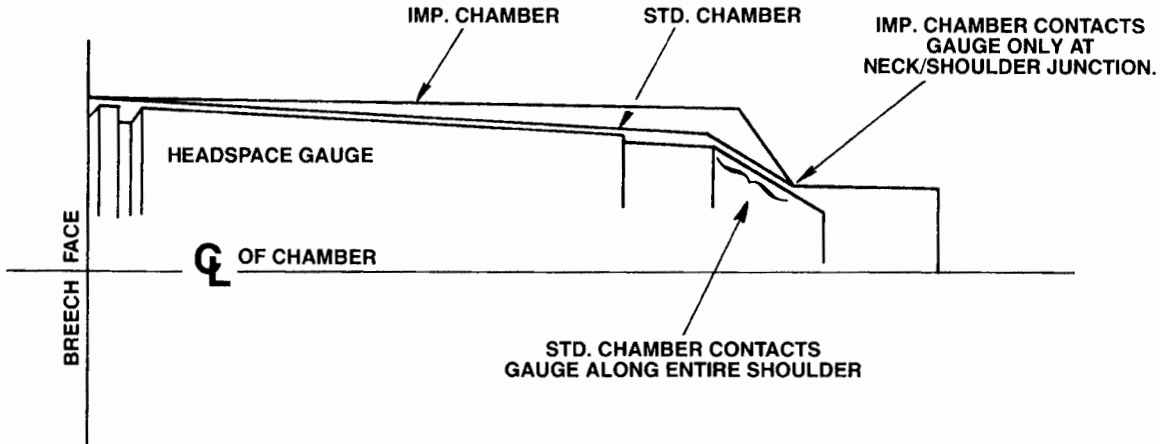

FIGURE 4



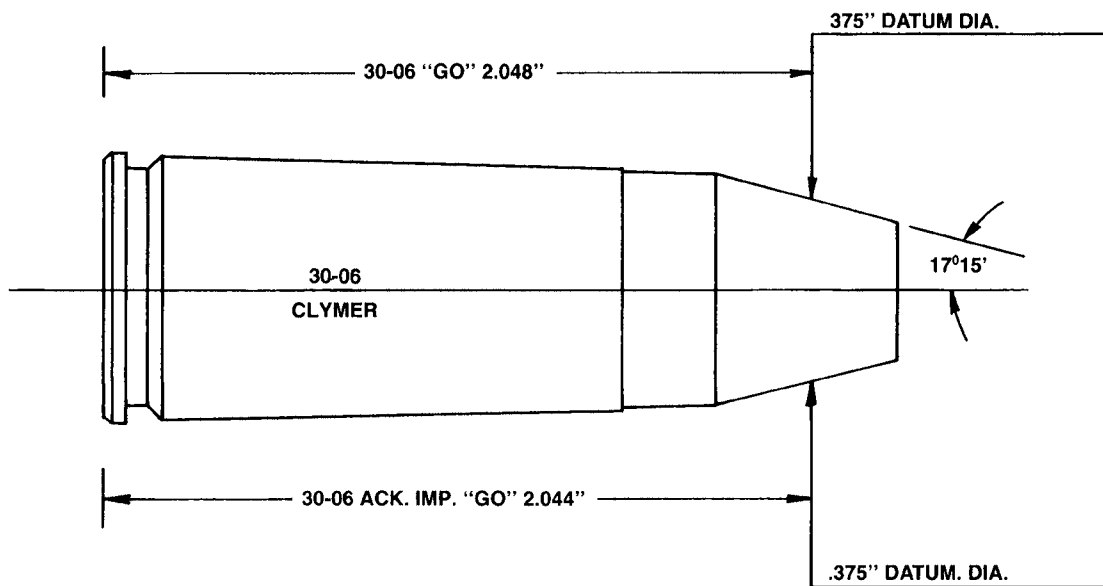

FIGURE 5

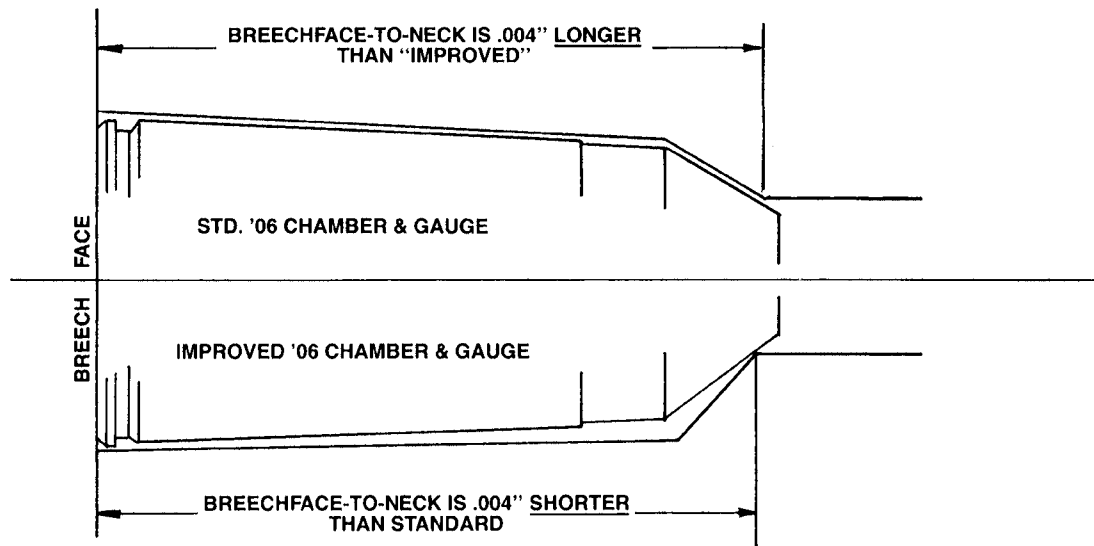
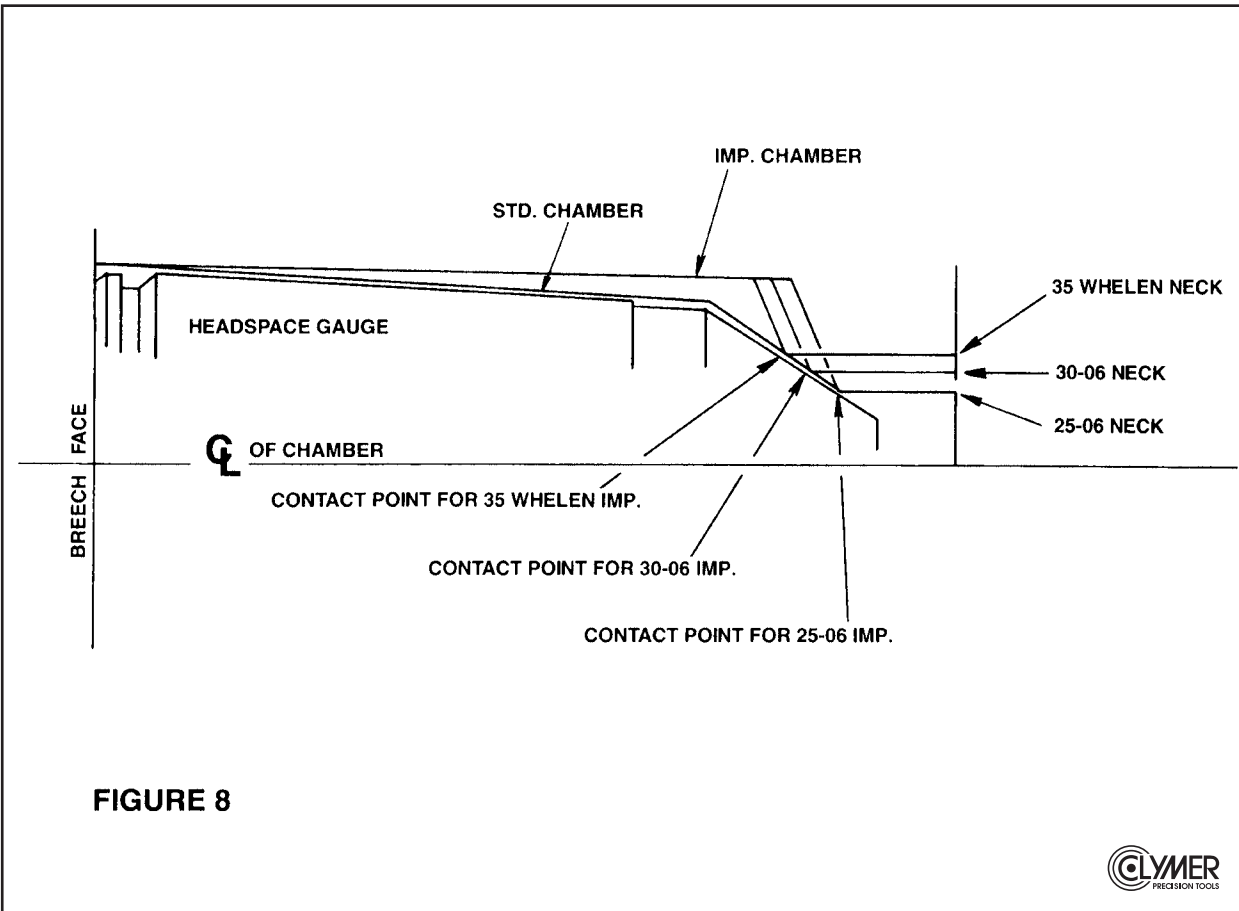
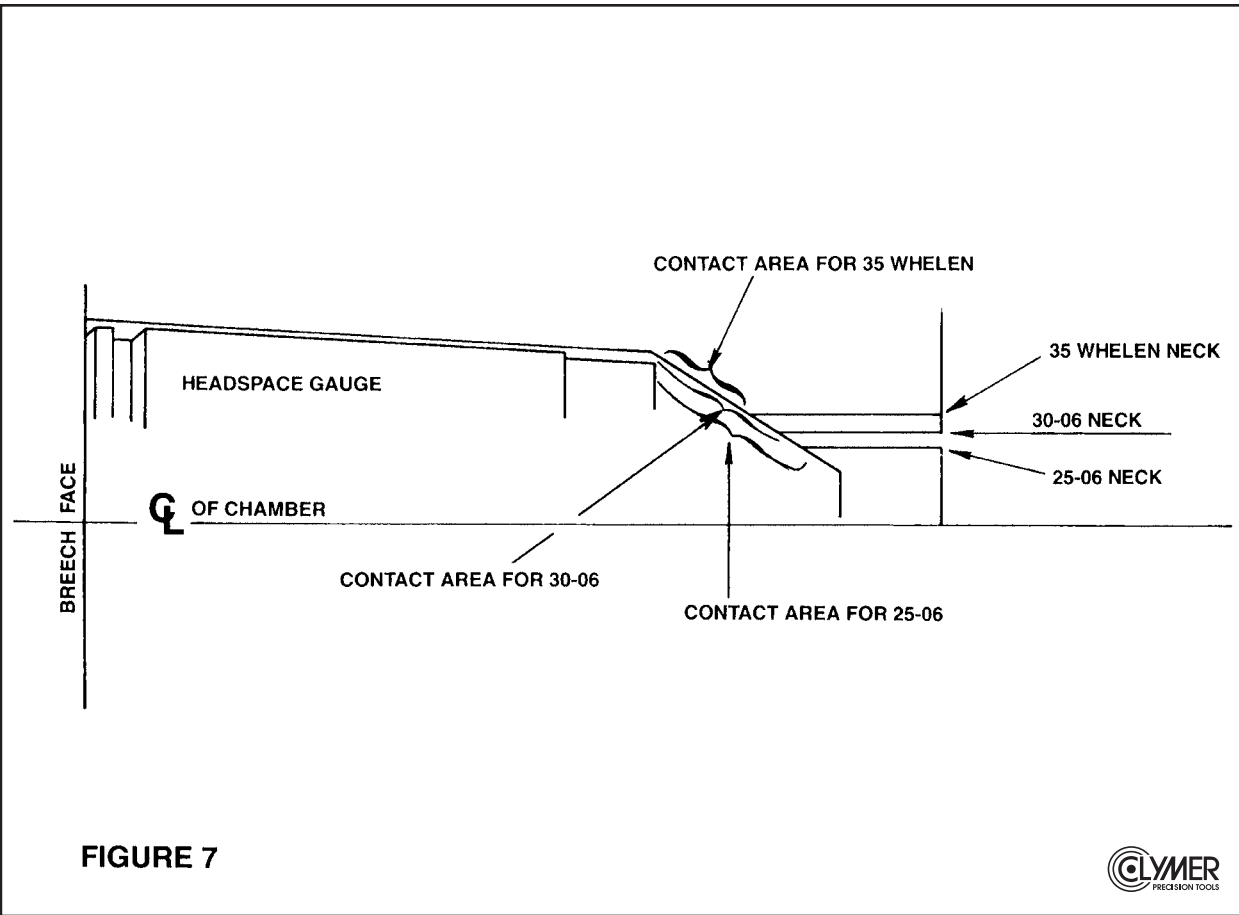

FIGURE 6





WILDCATS/SPECIALS

“SPECIALS” are just that-special, and each must be approached as a unique tool to cut a chamber for a cartridge designed to fulfill a specific purpose. A wildcat cartridge intended for use hunting dangerous game will require a chamber with considerably more clearance than will a cartridge intended for bench rest accuracy. Because of this, there really are no “standard clearances” for special chambering reamers. When we work with you to create a chambering reamer for your own wildcat, there are several things that must be kept in mind:

INTENDED USE OF THE WILDCAT

Will you be hunting dangerous game with your .577 Loudenboomer? If so, there should be more clearance between chamber and cartridge to facilitate rapid re-loading and to keep any dirt that might find its way into the gun from causing the cartridge to bind. Also, you may wish to use bullets to different weights and lengths on different game and for this reason, would want the reamer to cut a throat compatible with the longest/heaviest bullet being used.

Benchresters, on the other hand, will often stick with one specific bullet, seated very carefully to an exact depth, and will shoot in a single-shot mode where speed is least important. A special reamer in this case would be made to cut a chamber much closer in size to that of the cartridge.

BRASS PREPARATION AND CARE OF SAME

Equally as important as the intended use of a wildcat, the manner in which brass will be prepared and maintained will determine appropriate clearances between chamber and cartridge. Safety is paramount in wildcatting (as in all shooting) and conditions which cause operating pressures to reach dangerous levels must be avoided. Chamber neck sections that pinch the neck of the cartridge by being too short and/or too tight, extremely short throats, excessive headspace, etc. can all create high chamber pressure.

Should you decide on a “tight” chamber for our own use, you might consider if you will ever want to sell the gun. A prospective customer might not be too enthusiastic about having to turn and trim brass after every outing.

Freebore (diameter bullet clearance) can be held as close to actual bullet diameter as you wish, but again, keep in mind the implications of this. If the freebore is, say .0005” over bullet diameter, and the bullet not concentric with the rest of the case, it will cock to one side when chambered. At best, this would reduce the accuracy potential of the gun; at worst it could create high pressures.

Close throating, where the bullet is near, or actually engages the rifling has been demonstrated to improve accuracy when combined with a relatively gentle throat angle. If you would like to incorporate this feature into your special reamer, we recommend sending us a dummy round with the bullet you intend to use seated to the correct depth. We will then take measurements from the dummy and grind the throat of the tool to give the bullet/rifling relationship you want.

If you haven't yet settled on an ideal load, we can make your tool with no throat and provide a separate throating reamer with which the throat can be cut a little at a time. Some shooters will start with their bullets seated deeply in the case and throat their guns to suit. As the throat erodes and accuracy begins to drop off, they will re-cut the throat, seat their bullets out a little further, and have a “like new” throat.

WILDCATS/SPECIALS, continued

Nothing looks worse than an unsightly bulge at the base of a case fired in a brand new wildcat-chambered gun. This can be avoided by carefully selecting a lot of brass and then having the special reamer ground to match. In its published tolerances for centerfire rifle cartridges, SAAMI allows cartridge diameters to vary by as much as .008". Necks can be turned, case lengths can be trimmed to close dimensions, and shoulders can be blown out and forward without much grief, but it is difficult to change the base diameter of the brass. When buying a lot of brass, a representative number of cases taken at random (10% should be sufficient) should be measured to assure they fall within variances you consider reasonable. A little extra time taken at this stage can save quite a few headaches later on.

Length clearances are also dictated by cartridge preparation and care. Because of brass flow, we would not recommend a chamber neck length less than .010" longer than actual cartridges. Overall chamber length to the end of the case mouth would then also be a minimum of .010" longer than the actual case dimension.

PRINT BLANKS

The four blank prints included in this section are designed to assist you in arriving at finish chamber dimensions for your wildcat, and should apply to most special chambering reamers. Each page has two drawings on it, with spaces provided to fill in the dimensions we need to make your reamer. The top drawing is of the wildcat cartridge, the lower drawing is of the reamer. You will note that we ask you to fill in dimensions on both drawings, even though only the reamer drawing is needed to make the tool. We do this so we will be able to provide the exact tool you require without having to guess at your intentions and so that we (and you) will be able to spot any potential problems before they occur. It is much easier to change dimensions on paper before they have been transformed into steel. Fill out the prints, keep a copy for yourself, and send one to us with prepayment at the time you order your special. Be sure to include your phone number in case we need to contact you.

TO SUMMARIZE

In designing a special reamer, you will have to be guided by the use to which the gun will be put and the care with which you will maintain the cartridges being used. We can make chambering reamers to virtually any dimensions.

All the options we offer on our standard tools (removable pilots, oil grooves, etc.) can be incorporated in your tool. Rimmed and belted specials usually can use the headspace gauges of the original base care, while rimless wildcats generally require headspace gauges made to new dimensions. We are happy to supply these as well.

Should you wish to have sizing dies made for your wildcat, we can also provide a roughing chamber reamer which, when sent to the diemaker of your choice, can be used to make full-length re-size dies. The finish chamber reamer can usually be used to make a seating die.

We are limited only by your imagination. Let us know what you'd like to accomplish and we will work with you to achieve it.

IMPORTANT - WE STRONGLY RECOMMEND THAT YOU CHECK ALL DIMENSIONS OF ANY TOOL TO ASSURE YOURSELF THAT IT IS THE TOOL YOU ORDERED. PLEASE DO THIS BEFORE YOU USE THE TOOL. ON ALL SPECIAL TOOLS, WE MAKE EVERY EFFORT TO PROVIDE THE TOOL YOU WANT, BUT YOU MUST BE THE FINAL INSPECTOR. DIFFERENT WILDCATS ARE OFTEN CALLED SIMILAR NAMES AND CAN BE CONFUSED. IT IS BETTER TO CHECK YOUR TOOL BEFORE USING, THAN TO RUIN A BARREL.

RIMLESS, NO NECK

CARTRIDGE DIMENSIONS

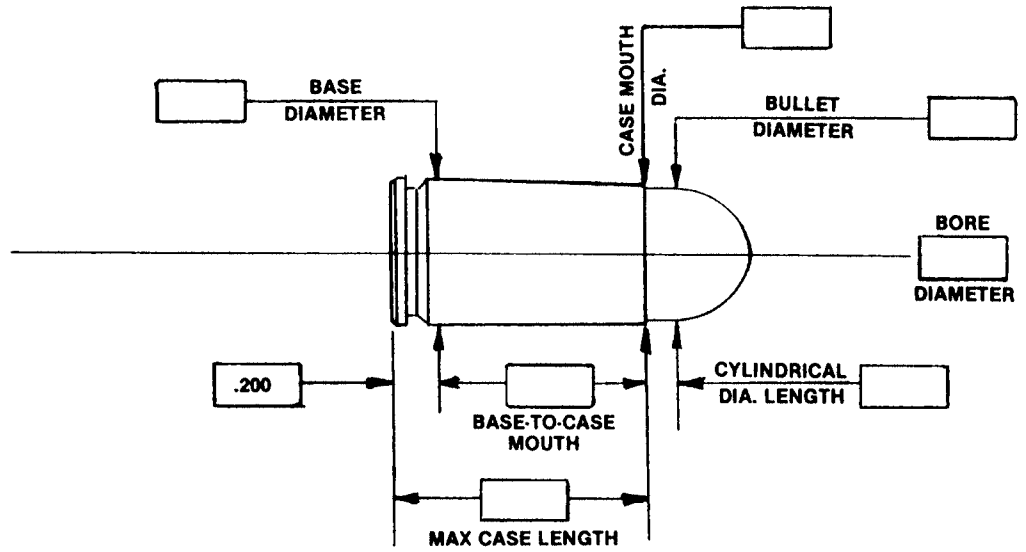

Cartridge Name _____ For _____



Approved _____ Date _____

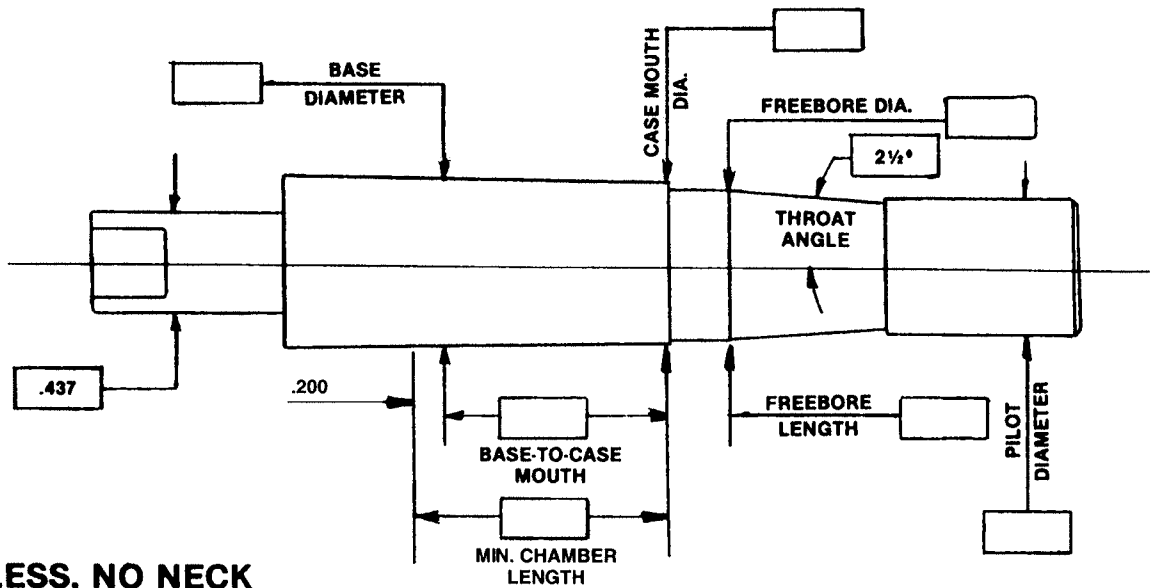

RIMLESS, NO NECK

REAMER/CHAMBER DIMENSIONS



**RIMMED/BELTED,
NO NECK**

CARTRIDGE DIMENSIONS

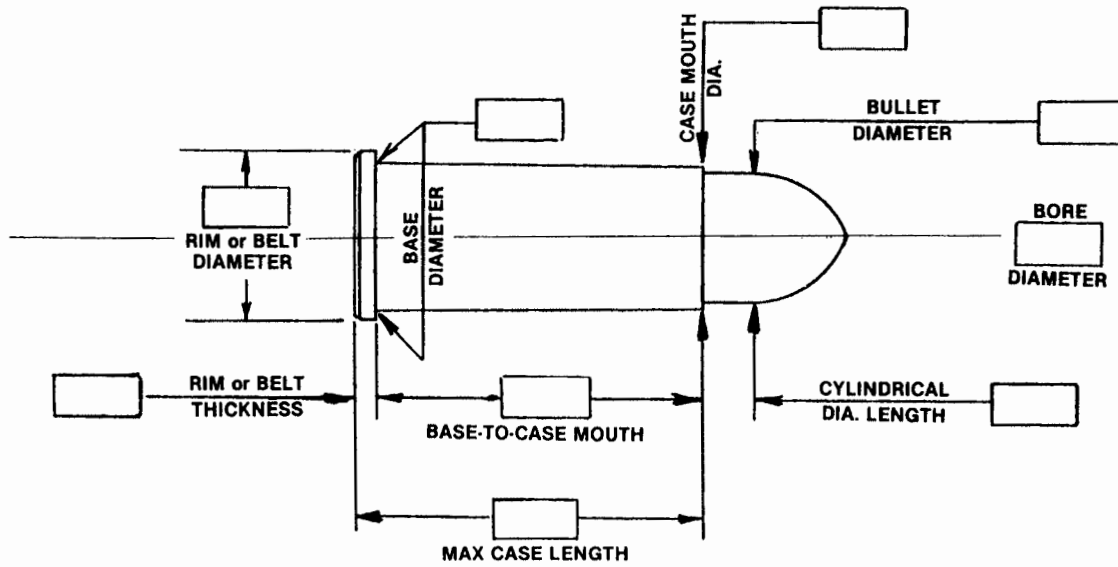

Cartridge Name _____ For _____



Approved _____ Date _____

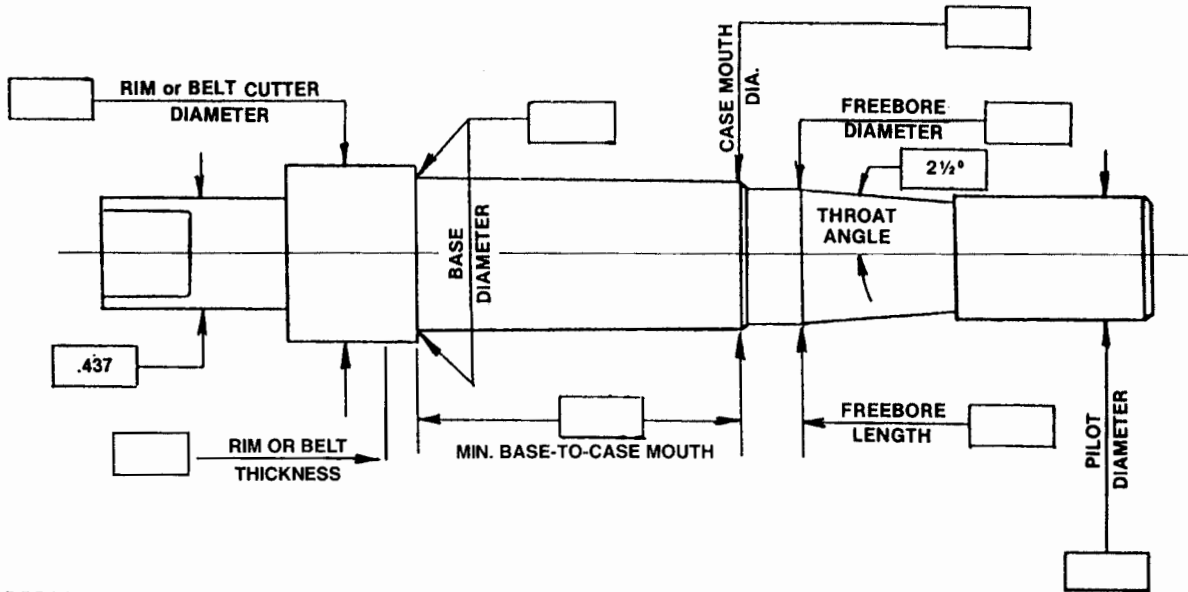

**RIMMED/BELTED,
NO NECK**

REAMER/CHAMBER DIMENSIONS



RIMLESS, WITH NECK CARTRIDGE DIMENSIONS

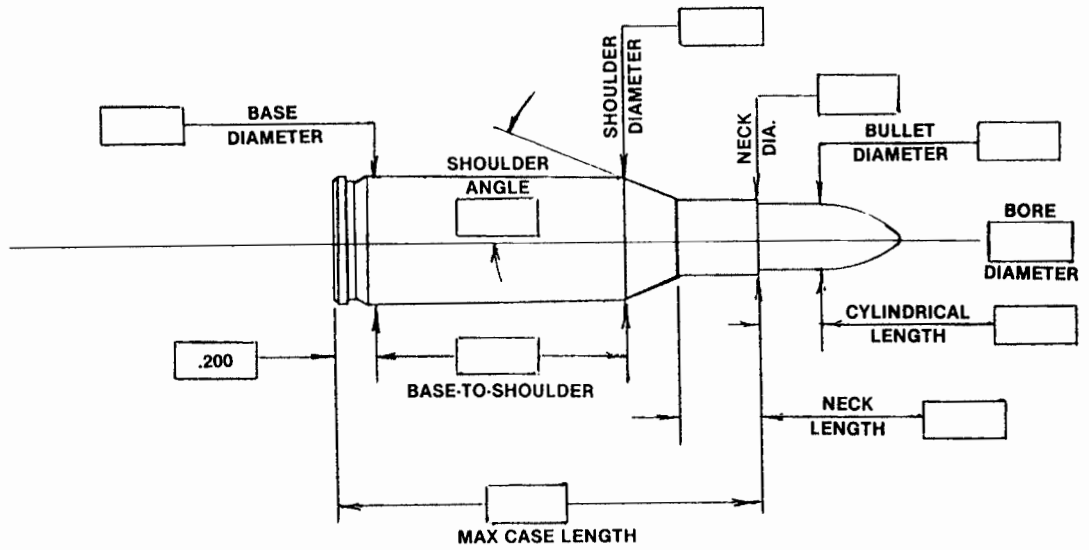

Cartridge Name _____ For _____



Approved _____ Date _____

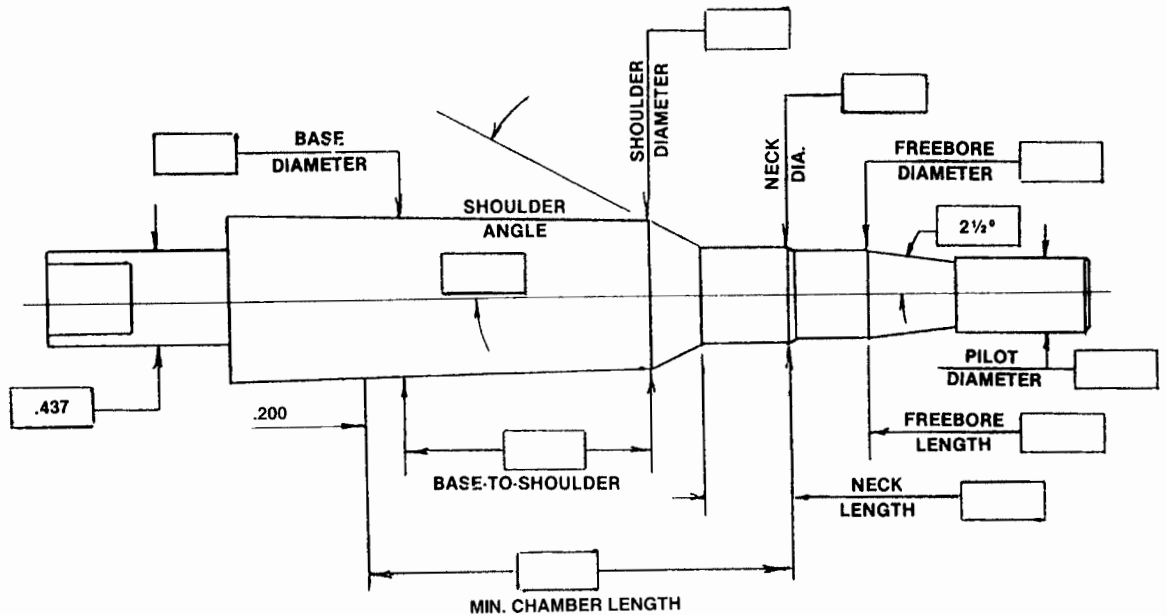

RIMLESS, WITH NECK

REAMER/CHAMBER DIMENSIONS



RIMMED or BELTED,
WITH NECK

CARTRIDGE DIMENSIONS

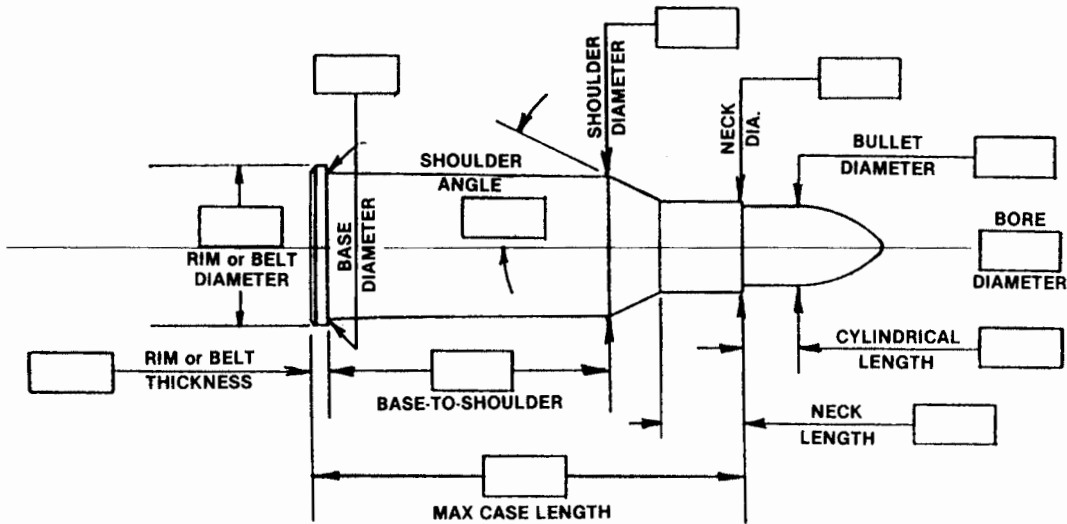

Cartridge Name _____ For _____



Approved _____ Date _____

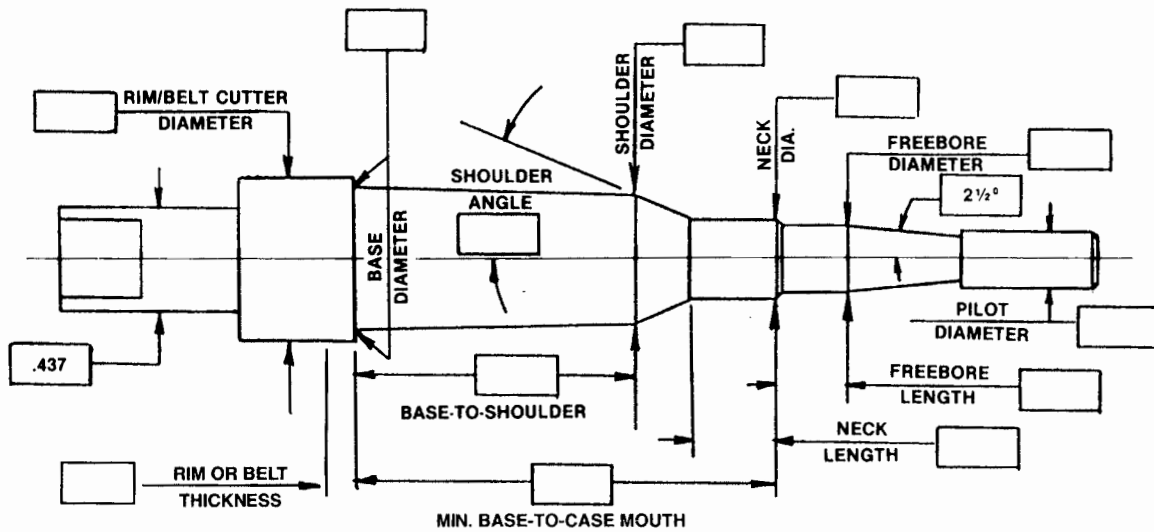

RIMMED or BELTED,
WITH NECK

REAMER/CHAMBER DIMENSIONS



OTHER CUTTING TOOLS

CLYMER MANUFACTURING makes a large selection of cutting tools, other than chambering reamers, which are intended to make life easier for the gunsmith and manufacturer. We are constantly adding to this list and welcome any suggestions you might have for new tools we could add to our catalog. All of the cutting tools in this section are made from HIGH SPEED STEEL, carefully hardened and drawn to give the best possible combination of durability and long cutting life. We are proud of these tools and feel that you will be proud to use them. All tools listed in our current pricelist are carried in stock for immediate delivery.

THROATERS



Sometimes called “freebore reamers”, throaters are used to extend the throat of a chamber in order to give more clearance around the bullet. Some gunsmiths will also order chambering reamers without a throat section and will then use a separate throater to cut the throat of the chamber to match a specific bullet. Clymer standard throaters are generally .002 larger than actual bullet diameter, with a $2\frac{1}{2}^\circ$ throat angle. We also offer these tools with a $1^\circ 30'$ throat angle and will be glad to grind any diameter or throat angle on a special-order basis.

All throaters have (5) left-hand spiral flutes to prevent the flutes from dropping into the rifling and to give a superior surface finish. The tool is 4” long with a 1/4” shank diameter to fit our Throater T-Handles.

NECK SIZING REAMERS



Neck Sizing Reamers are used to open up the neck diameter in a chamber, or to extend its length. This operation can sometimes relieve pressure problems caused by case necks that fit too closely to the walls of the chamber, or are crimped down on the bullet by a neck section that is too short for the cartridge.

While these tools are not intended to ream the necks of cartridge cases, we can alter them for this purpose—please ask. Throater T-Handles are used to drive these tools.

NECK AND THROAT COMBINATION REAMERS

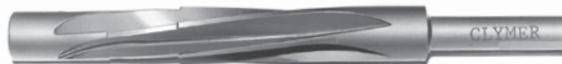

These tools cut both the neck and throat portions of a chamber. Often they are used with a chambering reamer for a smaller caliber fitted with an oversize bushing to create a chamber for a new, larger caliber. An example of this would be using a 30-06 reamer fitted with a 35 cal removable pilot to cut the body and shoulder portion of a chamber in a 35 caliber barrel. A 35 cal Neck and Throat Reamer would then be used to cut the neck and throat areas of the chamber with the result being a barrel chambered for 35 Whelen. Throater T-Handles are also used with Neck and Throat Reamers.

Variations on our standard dimensions are available as specials.

TAYLOR THROATER REAMERS

Short forcing cone reamers for revolvers

For some time now, Cowboy shooters have requested tools to improve the accuracy of their revolvers.



The Taylor Throater was engineered to work in conjunction or independently with the Clymer Cylinder Sizer to create a safer and more accurate revolver system. Specially designed for use with cast lead bullets, this tool will cut a short forcing cone in the barrel that will help solve the problem of splitting lead and true up the concentricity relationship between cylinder and barrel. Please see our current pricelist for caliber specific pricing and availability.

CYLINDER DE-LEADING TOOLS

If you shoot wadcutters, or even round-nose lead bullets in your revolver, you know about the lead build-up at the end of each chamber. The Clymer De-Leading Tool removes these deposits quickly and easily without having to use any solvents. Each tool is precision ground .0005" under the minimum SAAMI chamber configuration to insure complete clean-up. Made from High Speed Steel, the tool has (5) Spiral Flutes. (Instructions included.)

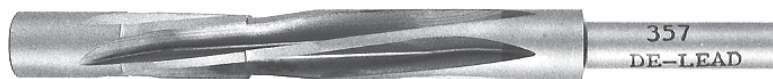

Our De-Leading Tools have been tested extensively at commercial ranges and should last a lifetime. Clubs may wish to consider a set for their members, and commercial ranges can quickly repay their investment by offering a de-leading service to their customers. Stocked for immediate delivery in the following sizes:

357 (for 38 Special, 357 Mag, 357 MAX)
41 Mag
44 (for 44 Special, 44 Mag)
45 Long Colt

We recommend our 7" Throater
T-Handle for use with these tools.

CYLINDER ACCURIZER

The Clymer Cylinder Accurizer is a system, not just a tool. The fixture, locking screw, pilot pin and reamer all work together to create an accurizing method that improves revolver performance.

The cylinder is first placed on the slide with the brass washer to prevent damage, but not fully tightened.

The pilot or alignment pin is then inserted to provide true alignment between the chamber and pilot bushing. The slide is locked into place with underside set screws and the cylinder screw is tightened.

Finally, the chamber is carefully hand reamed with the use of cutting oil and the process is repeated for each chamber. For this process, the slide remains fixed and just the cylinder is advanced to the next chamber. Please see pricelist for available sizes.

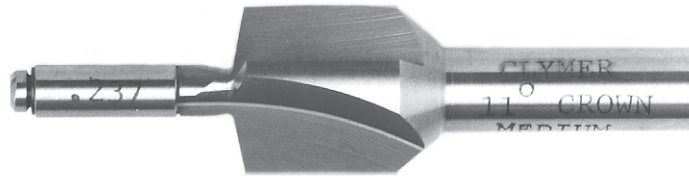

11° CROWNING REAMER

Engineered because of customer demand, these tools are intended to cut the popular 11° crown in rifle barrels. They are available in the same three size ranges as our Removable Pilot Center Drills and utilize the same pilot bushings. Like the Center Drills, the cutting edges are cam-relieved for smooth, burr-free cutting - very important when finishing the muzzle of a precision rifle.

These tools should save you time and make you money in your gunsmithing work.

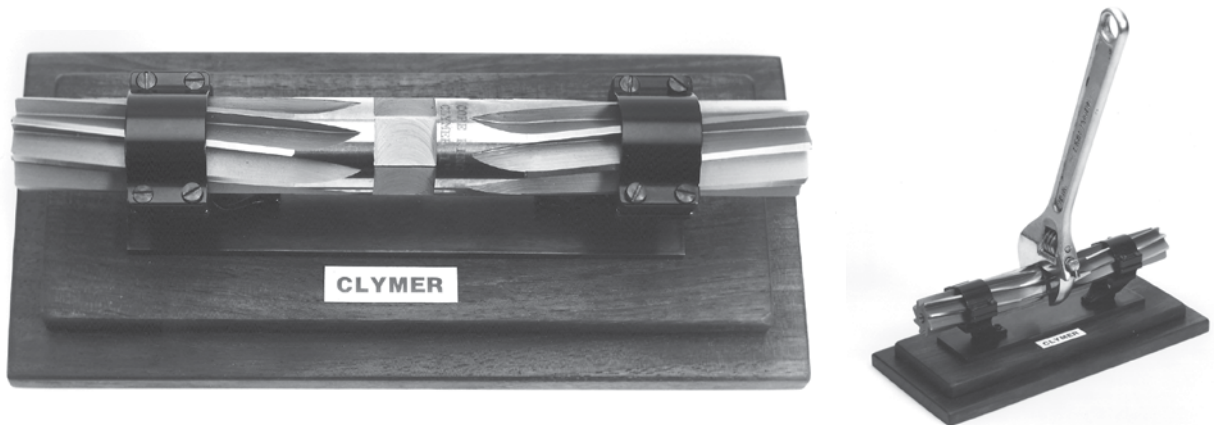
SCOPE RING ALIGNMENT REAMER

Have you ever had the experience of a scope slipping forward under recoil because it wasn't held securely in the rings? Worse yet, have you ever tightened and tightened scope rings to eliminate slippage only to have one of the screws break, or the scope tube dent due to ring misalignment?

Correct alignment between scope rings is critical in eliminating slippage or damage to valuable optics. Often, production tolerances of commercial rings are such that no matter how careful a 'smith drills and taps the scope mounting holes, misalignment still remains between the rings. Until now, the only way to achieve perfect alignment between scope rings was to lap them in - a time consuming process.

The above pictures show the new **CLYMER SCOPE RING ALIGNMENT REAMER** in operation. Before using the tool, the 'smith mounts scope rings in the usual manner. (Note: the Reamer can be used as an alignment bar in laying out the ring mounting holes.) Once the rings are secured to the firearm, the Reamer is placed in the rings and the caps lightly tightened. The Reamer is then rotated in the rings with a wrench until it turns easily. The caps are then tightened a little more and the Reamer turned again until it cleans up the inside surfaces of the rings. The result: properly aligned scope rings which hold the scope **securely and without distortion in a fraction of the time** required for lapping.

IMPORTANT: The Scope Ring Alignment Reamer is **not suitable** for use with Weaver "strap-type" rings, or vertically-split rings of the Buehler or Conetrol types. Other vertically -split rings should be evaluated on an individual basis.

96° FEED CONE REAMERS



An extremely useful tool when re-barreling actions such as the '17 Enfield, '03 Springfield, or the pre-'64 Winchester Model 70, these cutters create the feed cone in the breech of the barrel. Used prior to chambering, these tools are available in three pilot shank sizes that utilize the same pilot bushings as our Removable Pilot Center Drills. Odd-fluted to resist chatter, these HIGH SPEED STEEL cutters are carefully hardened and ground to produce an excellent finish.

Clymer 96° Feed Cone Reamers cut the exact angle required in these re-barreling jobs and are real time savers when compared to turning the feed cone on a lathe.

.705" BOLT BODY COUNTERBORES



For cutting the recess for the front part of the bolt body when re-barreling Remington 700 series actions. An improvement over previous designs, the Clymer BOLT BODY COUNTERBORE not only cuts the correct diameter for the bolt, but assures that the recess is cut to the right depth, since the end of the barrel is faced off the correct distance from the start of the .705" cutter at the same time. This represents a great time savings from cutting the recess on a lathe.

Made from M-7 HIGH SPEED STEEL, carefully hardened and ground to exacting tolerances, these tools utilize the same pilot bushings as our Removable Pilot Center Drills.

BARREL TURNING AID (BTA)

Purpose: This tool provides a convenient means by which the gunsmith can hold and center Remington 700 series and Mauser rifle barrels. These barrels have a constant taper and cannot be grasped by a lathe chuck in the normal manner.



Features: The tool is precision bored, recessed, and threaded to mate with the tapered barrel shanks. The outside diameter is ground concentric to the internal thread. The front and back faces are ground to 1.0000" thick and perpendicular to the thread axis. The perimeter surface of the tool is equipped with 0.250 diameter holes for a pin wrench, which is provided with the tool.

Application: The barrel shank is cleaned of all thread locker and debris. The Barrel Turning Aid (BTA) is screwed onto the barrel shank with the recess toward the barrel shoulder. Secure the BTA with the included wrench. Install the barrel and BTA into a 4-jaw chuck and align the bore to the lathe axis.

REMOVABLE PILOT CENTER DRILLS

When re-barreling, it is essential that the outside of the barrel be turned concentric to the bore. The best way to do this, or course, is to turn the barrel between centers. Clymer Removable Pilot Center Drills are used to cut a 60° female center on each end of the barrel prior to turning in the lathe. The bushing on the center drill pilots off the bore so concentricity with the 60° center is assured. Center Drills are made in (3) sizes (Small - for 22 cal; Medium - for 6MM thru 7MM; Large - for 30 cal and up) and sold separately, or as a set supplied in a wooden box with hinges and catch.

Each High Speed Center Drill has (3) CAM-RELIEVED cutting edges and a 3/8" ground shank for use in a lathe, drill press, or drill motor. Bushings are supplied for standard bore diameters, with each bushing marked for the bore diameter it is intended to fit - actual bushing diameter is .001" smaller for clearance in the bore. (Example: .300 marked bushing actually measures .299") Bushings are fastened to our center drills (and other tolls with removable pilots) with snap rings to prevent their loosening from vibration. All bushings used on center drills may also be used on our chambering reamers ground for removable pilots, providing both tools are in the same size range.

Our set of Removable Pilot Center Drills is a handsome addition to any gunsmith's toolbox and represents a savings over the cost of all items purchased separately. A set consists of (1) each; Small, Medium and Large Center Drills, and (12) bushings that cover bore sizes from 22 to 35 caliber, and (2) snap rings of each size. A list of bushings supplied with each set and their size range is given below:

Size Range	Bushing I.D.	Bushing O.D.
Small	9/64"	.217 and .219
Medium	3/16"	.237, .250, .256, .270, .275
Large	15/64"	.300, .312, .314, .330, .350

For your reference, a list of our standard bushing sizes and their actual diameters is given below. Sizes differing from these may be made to order.

SMALL RANGE

O.D.	Marked	Actual	Calibers
	.217	.216	22 Rimfire
	.219	.218	22 Centerfire, 22 WRFM

MEDIUM RANGE

O.D.	Marked	Actual	Calibers
	.237	.236	6MM
	.250	.249	25 Cal.
	.256	.255	6.5 MM
	.270	.269	270 Cal.
	.2755	.275	7MM

LARGE RANGE

O.D.	Marked	Actual	Calibers
	.298	.297	30 Cal.
	.300	.299	30 Cal.
	.314	.313	32 Cal.
	.330	.329	338 Cal
	.346	.345	9MM, 35 Cal PISTOL
	.350	.349	35 Cal. RIFLE
	.366	.365	375 Cal.
	.442	.441	45 Cal. PISTOL
	.450	.449	45 Cal. RIFLE



ACCESSORIES

The items listed in this section were designed to make the gunsmith's job that much easier. As with our other standard tools, all of the products shown here are stocked for quick delivery.

BARREL POLISHER

(Barrel Holding Fixture)



The Clymer Barrel Polisher is made of extruded aluminum, which is lightweight and easy to handle. Solid aluminum ends, carrying sealed ball bearings and delrin centers, are adjustable and lock in place with a socket screw. Barrels up to 32" long may be held in the fixture for polishing.

In use, the barrel is placed securely in the fixture and the barrel held against a buffing wheel. The speed with which the barrel rotates can be controlled by varying the angle at which it makes contact with the wheel - a real timesaver on re-barreling jobs.

Delrin Centers: bearings and barrel polisher ends (arms) are all available as replacement items from our factory.

FLOATING REAMER HOLDER



It is important, when chambering, that the axis of the chambering reamer be aligned with the bore. If the two are misaligned, the result is usually a chamber cut oversize at the base. A cartridge fired in a chamber such as this will exhibit a bulge at the base of the case - unsightly at best, and dangerous at worst.

The floating portion of the holder has a precision-honed hole that fits our rifle and pistol chambering reamers with 7/16" shanks. **An adaptor bushing is also available for tools with 1/4" shanks such as 22 Rimfire Reamers, Throaters, etc. A set screw is provided to secure the tool in the holder.**

Clymer Floating Reamer Holders are available with 3/8" and 1/2" straight shanks for use with chucks and collets; or with No. 2 Morse Taper and No. 3 Morse Taper shanks to fit the tailstock spindle of a lathe.

EXTENSIONS & T-HANDLES

For use with our chambering reamers, throaters, etc., Clymer Manufacturing's Extensions and T-Handles are made from cold-drawn steel with dimensions held to close tolerances to insure proper fits with tools for which they are intended.

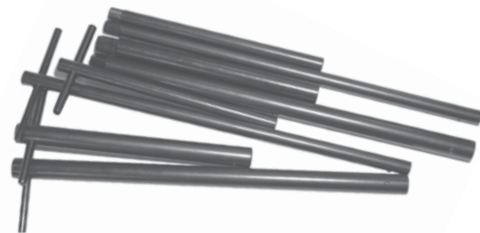

"Rifle" Extensions and T-Handles have a 7/16" reamed hole that slips over the shanks of our rifle and pistol chambering reamers (except 22 Rimfire) and are secured with an allen set screw.

"Throater" Extensions and T-Handles are used with 22 Rimfire chambering reamers and all throating-type tools having 1/4" diameter shanks. (Throaters, Neck Sizers, Neck and Throat Combinations, Pistol Forcing Cone Reamers, De-Leading Tools). Allen set screws are also used to hold tools in the "Throater" Extensions and T-Handles. All T-Handles and Extensions are offered in 7" and 12" lengths.

Our shotgun Bore Reamers are designed to be driven with our 34" extensions (not pictured). These are supplied in (3) sizes; **Large**, to be used with 10, 12 and 16 Gauge reamers; **Medium**, for use with 20 and 28 Gauge tools; and **Small**, for 410 Gauge only. These, too, are made from cold-drawn steel to high Clymer standards.

OPTIONS/ALTERATIONS

BODY, NECK/SHOULDER, THROAT ALTERATIONS

Our standard tools work well for the majority of gunsmiths, but there are always instances in which a tool should be altered in order to achieve the desired results. An example of this would be a varmint shooter whose lot of 22-250 brass measures small, say .462", at the base. To avoid a bulge at the base of his fired cases, this shooter would ask that we grind the base diameter of his 22-250 chambering reamer to .464", instead of the standard .469". Another shooter may plan on neckturning his 22 PPC cases to thinner-than-normal dimensions and, for this reason, would want us to reduce the neck diameter of his reamer prior to shipping.

We are able to alter any and all of the dimensions of our standard tools to meet your specific needs. Our price list divides the tool into three sections (Body, Neck and Shoulder, Throat) for pricing. If two or more sections of the tool are to be altered, we will price it as a special, since this is the least expensive way to go. Tools altered by the customer or by us at the customer's request are not returnable for credit.

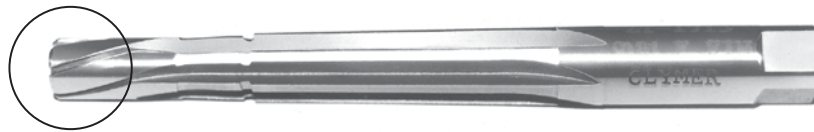

OIL GROOVES

This alteration is quite useful in production chambering when large numbers of barrels are to be machined. Flutes on a reamer normally stop approximately 1/2" from the pilot end of the tool in order to provide a solid bearing surface within the bore. For production chambering, these flutes are extended to the end of the pilot with narrow grooves to allow cutting oil, pumped through the muzzle of the barrel, to flush chips of the breech. Oil grooves may be installed on all of our reamers (22 caliber and larger) that pilot off the bore.

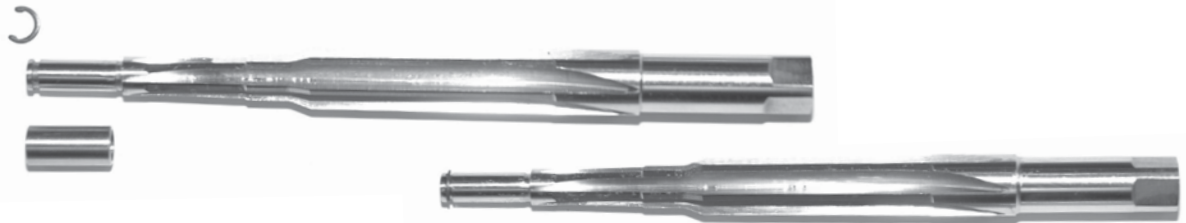

REMOVABLE PILOTS

Barrel bore diameters vary from maker to maker, and removable pilots can be an advantage when chambering. Also, by using removable pilots of different diameters in conjunction with appropriate neck-and-throat combination reamers, several calibers may be chambered using one basic chambering reamer. Smaller reamers with removable pilots can be used to cut body and shoulder for large calibers. (Example: 25-06 with different bushings and neck-and-throat reamers can chamber 25-06, 6.5-06 270.) Larger calibers even though fitted with smaller bushings cannot be used for smaller caliber chamberings unless neck and throat sections are reduced accordingly.

Standard Pilot bushings are the same as those listed with our Center Drill Set. They are secured to the reamer with snap rings and are interchangeable within a particular size range. All of our cutting tools (22 caliber and larger) that pilot off the bore may be fitted with removable pilots.

RESHARPENING/REGRINDING

Most Clymer tools, unless they are badly nicked, worn or stoned undersize, can be re-sharpened when dull. Straight-fluted tools may be ground on the flute faces to regain “like-new” sharpness, while spiral-fluted tools have to be re-cleared to achieve the same result.

Every tool we get back for re-sharpening is different in terms of its condition. For this reason, we have to decide, on an individual basis, the best manner in which to re-sharpen a particular tool. If the tool may be re-sharpened in the least expensive way, we will proceed to do this and return the tool to you. If, however, the tool requires a complete re-grinding, or is worn beyond acceptable limits, we will inform you of this as well as the various options and will await your instructions concerning the tool. **WE RECOMMEND THAT YOU ASK FOR A QUOTATION ON ALL RE-SHARPENING WORK.**

Protect your tooling investment by packing reamers carefully to avoid damage to their cutting edges - we have seen many tools, which could have been re-sharpened successfully, damaged beyond repair as a result of inadequate packing. Clean all tools you plan to return so as to be able to assess their condition, and wrap them individually with sufficient packing material to prevent damage.

WE ARE THOROUGHLY FAMILIAR WITH THE STANDARDS TO WHICH OUR TOOLS ARE MADE, BUT DO NOT KNOW THE MANUFACTURING PRACTICES OF OTHER REAMER MAKERS. BECAUSE OF THIS, WE WILL RESHARPEN CLYMER TOOLS ONLY.

ORDER AND SHIPPING INFORMATION

TO ORDER: We have enclosed order blanks to use when ordering tools. Standards in stock will be shipped immediately. To help speed processing of your special order, please either send us a dummy round, or use the print blanks found in the section entitled "Wildcats-Specials." We will then send you a copy of proposed reamer dimensions for your approval or correction. Special order tooling must be prepaid and usually takes two weeks or more to manufacture after we receive approval of proposed tool dimensions. If we have any questions concerning your order, we will, of course, contact you before making the tool.

PAYMENT: Minimum order accepted is \$30.00. We do accept most major credit cards. We accept payment by Company Check or COD for all standard stock tool orders. If you are a New Account, we may ship COD-Cash or Certified Funds until credit has been established.

SHIPPING: We ship by UPS or, when specified, First Class Mail. (Orders from customers in Hawaii and Alaska can only be shipped by U.S. Mail.)

All shipping charges will include insurance of the package against loss. When ordering, please make sure to give us a shipping address, as well as a mailing address to guarantee arrival of your order.

CHARGES: USA Shipping & Insurance.....\$8.50
INTERNATIONAL Shipping & Insurance.....\$35.00
Via Air parcel Post

EXCEPTIONS: Barrel Polisher, 34" T-Handle Extension,
Larger Orders.....Quote

Air Mail: Available. Please call for quote.

COD: Charges can be calculated at the time you are ordering.

NSF CHECKS: On checks returned to us for non-payment, we will charge a \$25.00 fee.

OPENING AN ACCOUNT: Please call us if you wish to open an account with Clymer.

RETURNS: Returns for credit or replacement must be done within 30 days, and include a copy of the invoice. No returns are allowed without prior approval. Returns are subject to a 10% restocking charge.

DISCOUNTS: None. These are factory prices.

* Many of our tools can also be ordered through Brownells.

MAIL ORDER FORM



1605 WEST HAMLIN ROAD
ROCHESTER HILLS, MI 48309 USA

Phone: (248) 853-5555 • Fax: (248) 853-1530 (24 hrs.)

- SHIP VIA**
- UPS GROUND
 - 1-DAY AIR
 - 2-DAY AIR
 - PARCEL POST
 - OTHER

*WE MUST HAVE STREET DELIVERY ADDRESS FOR UPS

- IF OUT OF STOCK**
- BACK ORDER
 - CANCEL

- PAYMENT**
- CHECK
 - CREDIT CARD
 - MONEY ORDER
 - CASH - C.O.D.

Customer I.D. Number _____

Phone No. _____ Fax _____

Date _____

Name _____

PREVIOUS ADDRESS OR NAME (IF DIFFERENT): _____

Street _____

City & State _____ Zip Code _____

Ship To _____

CHECK BOX IF NEW CUSTOMER

QTY.	CALIBER	DESCRIPTION	UNIT PRICE	TOTAL

"European Customers: Please include your VAT Number"

FOR CREDIT CARD ORDER - PLEASE FILL IN BELOW

DISCOVER MASTERCARD
 AMERICAN EXPRESS VISA

CARD HOLDER NAME

CARD NUMBER

EXPIRES 3 DIGIT SEC. CODE

SIGNATURE

TOTAL FOR ORDER	
SHIPPING & INSURANCE*	
AIR MAIL	
TOTAL AMOUNT ENCLOSED	

***EXCEPTIONS: Additional Charges May Apply**
For: Barrel Polishers, 34" Extensions or large orders

MAIL ORDER FORM

LIMITED WARRANTY

All products made by Clymer Manufacturing Co., Inc. are warranted to be free from defects in material and workmanship for ninety (90) days after shipment. We make each of our tools to specific standards that are well-proven. Should you have any questions as to whether a tool you received meets these standards, please contact us and we will be glad to discuss the sizes and tolerances to which your tool was made. Since we are constantly improving our products, all specifications are subject to change without notice.

WE STRONGLY RECOMMEND THAT YOU CHECK ALL DIMENSIONS OF ANY TOOL TO ASSURE YOURSELF THAT IT IS THE TOOL YOU ORDERED. PLEASE DO THIS BEFORE YOU USE THE TOOL. ON ALL SPECIAL TOOLS, WE MAKE EVERY EFFORT TO PROVIDE THE TOOL YOU WANT, BUT YOU MUST BE THE FINAL INSPECTOR. DIFFERENT WILDCATS ARE OFTEN CALLED SIMILAR NAMES AND CAN BE CONFUSED. IT IS BETTER TO CHECK YOUR TOOL BEFORE USING IT THAN TO RUIN A BARREL.

We have found that the vast majority of reamer breakage is the result of misuse. Reamers have to be made hard in order to resist wear and this makes them somewhat brittle. The flutes cannot be too thick or else there will not be adequate chip clearance. In addition, chambering reamers, unlike most other cutting tools, cut along their entire length. This means that chambering reamers are likely to break if misused. Chambering reamers for 17 and smaller calibers are even more susceptible to these problems and, for this reason, we cannot be responsible for breakage of these tools.

If, for any reason, you feel a tool is not performing as it should, we will be happy to check it dimensionally at no charge to insure it meets our high manufacturing standards. Should the tool not meet these standards, it will either be repaired or replaced **AT OUR OPTION**.

Sometimes a customer asks that a test chamber be cut with a tool he has returned. We will be glad to do this, but if the tool is dimensionally correct and also performs well cutting the test chamber, we will charge for this service. Test chambers are cut in 4140 Chrome-Moly barrel steel. Should the customer want the reamer tested in a different barrel material (e.g. stainless steel), he must send a section of barrel, in the appropriate caliber, at least 5" long, and no larger than 1" diameter. We will then test the tool in this material. Again, should the reamer be dimensionally correct and perform properly, we may charge for this service.

Refunds or exchanges will be issued only after Clymer personnel have established the returned tool did not meet standards in effect **at the time the tool was manufactured**. Specifications change over time and tools made to one set of dimensions cannot be expected to meet current specifications.

Refunds will be made in **U.S. Dollars** and not in goods of any form. Exchanges will be sent to the customer by normal shipping unless the customer requests, and pays for, a faster shipping method.

Any claim for damages above and beyond the cost of the tool (e.g. barrels, cases) will not be considered until said items are returned post paid to the Clymer facility for examination. Upon payment of a claim involving these items, the items become the property of Clymer Manufacturing Co., Inc. **All claims must be made within ninety (90) days of shipment of the tool(s) in question. No claims will be considered for labor, overhead, or loss of profits. Any alterations to our tools by other than Clymer Manufacturing automatically voids warranty.**

Clymer Manufacturing's reputation is second-to-none in our field. We strive constantly to maintain our high standards and, at the same time, provide complete customer satisfaction. If you have any questions, please contact us so we may work together to achieve these goals.

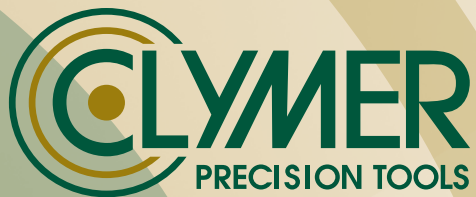

MEMBER NSSF MEMBER NRA

Reamers, Gauges and Associated Tooling for the Gunsmith and Manufacturer

PRECISION TOOLS

1605 West Hamlin Rd., Rochester Hills, MI 48309 USA

PRODUCT CATALOG

Toll Free 877-732-6377

Ph 248-853-5555

Fax 248-853-1530

Web www.clymertool.com